

# Keysight 33502A 2-Channel Isolated Amplifier

# Notices

© Keysight Technologies, Inc. 2009-2020

No part of this manual may be reproduced in any form or by any means (including electronic storage and retrieval or translation into a foreign language) without prior agreement and written consent from Keysight Technologies, Inc. as governed by United States and international copyright laws.

## Manual Part Number

33502-90001

## Edition

Edition 4, April 8, 2020

## Printed in:

Printed in Malaysia

## Published by:

Keysight Technologies  
Bayan Lepas Free Industrial Zone,  
11900 Penang, Malaysia

## Technology Licenses

The hardware and/or software described in this document are furnished under a license and may be used or copied only in accordance with the terms of such license.

## Declaration of Conformity

Declarations of Conformity for this product and for other Keysight products may be downloaded from the Web. Go to <http://www.keysight.com/go/conformity>. You can then search by product number to find the latest Declaration of Conformity.

## U.S. Government Rights

The Software is “commercial computer software,” as defined by Federal Acquisition Regulation (“FAR”) 2.101. Pursuant to FAR 12.212 and 27.405-3 and Department of Defense FAR Supplement (“DFARS”) 227.7202, the U.S. government acquires commercial computer software under the same terms by which the software is customarily provided to the public. Accordingly, Keysight provides the Software to U.S. government customers under its standard commercial license, which is embodied in its End User License Agreement (EULA), a copy of which can be found at <http://www.keysight.com/find/sweula>. The license set forth in the EULA represents the exclusive authority by which the U.S. government may use, modify, distribute, or disclose the Software. The EULA and the license set forth therein, does not require or permit, among other things, that Keysight: (1) Furnish technical information related to commercial computer software or commercial computer software documentation that is not customarily provided to the public; or (2) Relinquish to, or otherwise provide, the government rights in excess of these rights customarily provided to the public to use, modify, reproduce, release, perform, display, or disclose commercial computer software or commercial computer software documentation. No additional government requirements beyond those set forth in the EULA shall apply, except to the extent that those terms, rights, or licenses are explicitly required from all providers of commercial computer software pursuant to the FAR and the DFARS and are set forth specifically in writing elsewhere in the EULA. Keysight shall be under no obligation to update, revise or otherwise modify the Software. With respect to any technical data as defined by FAR 2.101, pursuant to FAR 12.211 and 27.404.2 and DFARS 227.7102, the U.S. government acquires no greater than Limited Rights as defined in FAR 27.401 or DFAR 227.7103-5 (c), as applicable in any technical data.

## Warranty

THE MATERIAL CONTAINED IN THIS DOCUMENT IS PROVIDED “AS IS,” AND IS SUBJECT TO BEING CHANGED, WITHOUT NOTICE, IN FUTURE EDITIONS. FURTHER, TO THE MAXIMUM EXTENT PERMITTED BY APPLICABLE LAW, KEYSIGHT DISCLAIMS ALL WARRANTIES, EITHER EXPRESS OR IMPLIED, WITH REGARD TO THIS MANUAL AND ANY INFORMATION CONTAINED HEREIN, INCLUDING BUT NOT LIMITED TO THE IMPLIED WARRANTIES OF MERCHANTABILITY AND FITNESS FOR A PARTICULAR PURPOSE. KEYSIGHT SHALL NOT BE LIABLE FOR ERRORS OR FOR INCIDENTAL OR CONSEQUENTIAL DAMAGES IN CONNECTION WITH THE FURNISHING, USE, OR PERFORMANCE OF THIS DOCUMENT OR OF ANY INFORMATION CONTAINED HEREIN. SHOULD KEYSIGHT AND THE USER HAVE A SEPARATE WRITTEN AGREEMENT WITH WARRANTY TERMS COVERING THE MATERIAL IN THIS DOCUMENT THAT CONFLICT WITH THESE TERMS, THE WARRANTY TERMS IN THE SEPARATE AGREEMENT SHALL CONTROL.

## Safety Information

### CAUTION

A CAUTION notice denotes a hazard. It calls attention to an operating procedure, practice, or the like that, if not correctly performed or adhered to, could result in damage to the product or loss of important data. Do not proceed beyond a CAUTION notice until the indicated conditions are fully understood and met.

### WARNING

A WARNING notice denotes a hazard. It calls attention to an operating procedure, practice, or the like that, if not correctly performed or adhered to, could result in personal injury or death. Do not proceed beyond a WARNING notice until the indicated conditions are fully understood and met.

## Software Updates/Licenses

Periodically, Keysight releases software updates to fix known defects and incorporate product enhancements. To search for software updates and the latest documentation for your product, go to the product page at:

[www.keysight.com/find/33502A](http://www.keysight.com/find/33502A)

A portion of the software in this product is licensed under terms of the General Public License Version 2 ("GPLv2"). The text of the license and source code can be found at:

[www.keysight.com/find/GPLV2](http://www.keysight.com/find/GPLV2)

This product utilizes Microsoft Windows CE. Keysight highly recommends that all Windows-based computers connected to Windows CE instruments utilize current anti-virus software.

## Safety Information

### WARNING

Do not defeat power cord safety ground feature. Plug in to a grounded (earthed) outlet.

Do not use product in any manner not specified by the manufacturer.

Do not install substitute parts or perform any unauthorized modification to the product. Return the product to an Keysight Technologies Sales and Service Office for service and repair to ensure that safety features are maintained.

Do not operate in an explosive atmosphere or wet environment.

Do not operate the instrument in the presence of flammable gases or fumes.

This instrument is intended for indoor use.

## Safety Symbols



Earth Ground



Chassis Ground



Risk of electric shock



Refer to manual for additional safety information

## WARNING

**Main Power and Test Input Disconnect: Unplug instrument from wall outlet, remove power cord, and remove all cables from all terminals before servicing. Only qualified, service-trained personnel should remove the cover from the instrument.**

## WARNING

**Line and Current Protection Fuses: For continued protection against fire, replace the line fuse and the current-protection fuse only with fuses of the specified type and rating.**

## CAUTION

**The instrument is designed for use in Overvoltage Category II and Pollution Degree 2.**

### Additional Notices

#### Waste Electrical and Electronic Equipment (WEEE) Directive 2002/96/EC

This product complies with the WEEE Directive (2002/96/EC) marking requirement.

The affixed product label (see below) indicates that you must not discard this electrical/electronic product in domestic household waste.

Product Category: With reference to the equipment types in the WEEE directive Annex 1, this product is classified as a "Monitoring and Control instrumentation" product.

Do not dispose in domestic household waste.

To return unwanted products, contact your local Keysight office, or see

[www.keysight.com/environment/product](http://www.keysight.com/environment/product)

for more information.



# Contents

## 1 Quick Start

The Front Panel at a Glance . . . . .	8
The Rear Panel at a Glance . . . . .	9
The Display at a Glance . . . . .	10
Basic Amplifier Operations . . . . .	11
Preparing the Amplifier for Use . . . . .	11
Using the Front Panel . . . . .	12
Basic Amplifier Troubleshooting . . . . .	14
If the Amplifier Does Not Turn On . . . . .	14

## 2 Features and Functions

SCPI Programming Introduction . . . . .	18
Front Panel Features . . . . .	19
Front Panel Display . . . . .	19
Displayed Messages . . . . .	19
Front Panel Main Menu . . . . .	20
Utility Menu . . . . .	20
File Menu . . . . .	22
System Menu . . . . .	23
I/O Config Menu . . . . .	24
Annunciators . . . . .	25
Turning the Display Off . . . . .	25
Front Panel Alphanumeric Character Entry . . . . .	26
Error Conditions . . . . .	26
Reading the Error Queue . . . . .	27
Mass Memory (MMEMory) Subsystem . . . . .	28
Power-On and Reset State . . . . .	29

## 3 Remote Interface Configuration

Configuring the USB Interface . . . . .	33
Configuring the LAN Interface . . . . .	34
Configuring LAN Parameters . . . . .	34
DHCP . . . . .	34
IP Address . . . . .	35
Subnet Mask . . . . .	35
Default Gateway . . . . .	36
Host Name . . . . .	37
DNS Server . . . . .	38
Instrument Unexpectedly Goes into Remote . . . . .	38
Setting up a LAN connection from the Front Panel . . . . .	39
Setting up a LAN connection from the Remote Interface . . . . .	40

## 4 Service Information and Typical Characteristics

Service Information . . . . .	44
Verifying Amplifier Functionality . . . . .	44
Gain, Flatness, and Full Power Bandwidth Tests . . . . .	45
Output Current Tests . . . . .	46
Internal Switching Tests . . . . .	47
Types of Service Available . . . . .	48
Extended Service Contracts . . . . .	48
Obtaining Repair Service (Worldwide) . . . . .	48
Repackaging for Shipment . . . . .	49
Cleaning Instructions . . . . .	49
To Order Replaceable Parts . . . . .	50
Typical Characteristics . . . . .	51
General Characteristics . . . . .	52
. . . . .	53
Input Configuration . . . . .	54
Output Configuration . . . . .	55

## Index

# 1 Quick Start

This chapter gives you a quick overview of the 33502A amplifier's front panel and basic features. The examples will help you become familiar with your amplifier and its basic operation.

The Front Panel at a Glance	8
The Rear Panel at a Glance	9
The Display at a Glance	10
Basic Amplifier Operations	11
Preparing the Amplifier for Use	11
Using the Front Panel	12
Basic Amplifier Troubleshooting	14
If the Amplifier Does Not Turn On	14
To Adjust the Carrying Handle	15
To Rack Mount the Amplifier	16

## The Front Panel at a Glance

The Keysight 33502A is a two-channel, isolated amplifier. Both channels can either propagate a signal directly or with 5x amplification. The channel inputs are on the rear panel of the amplifier, and the outputs are either on the front panel, as shown here, or on the rear panel (Option 001 only). The main front panel features are shown below.

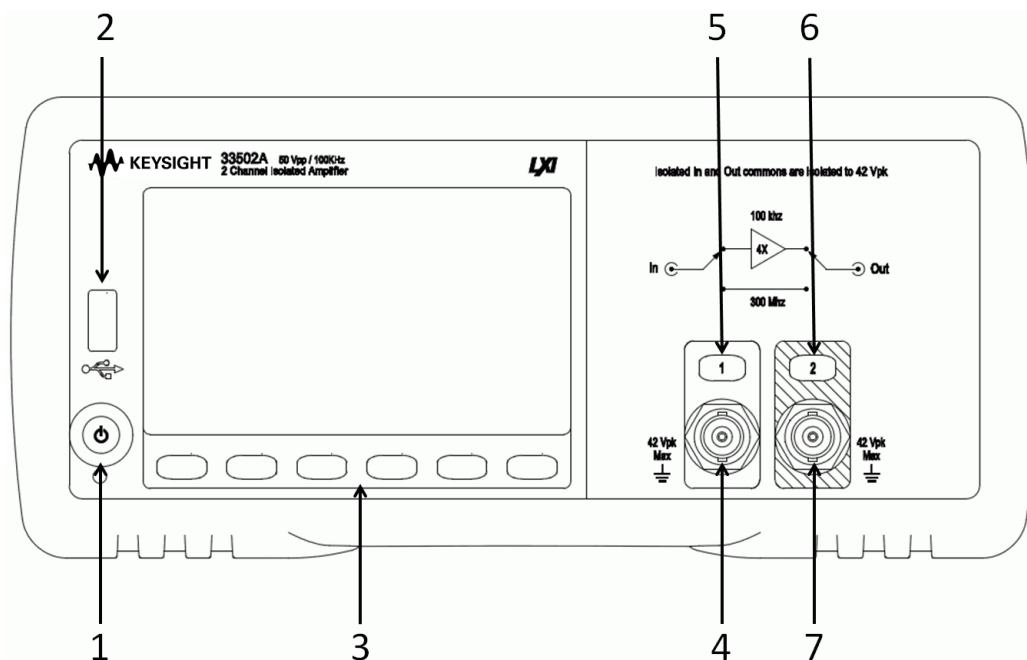

- 1 On/Off Switch and power LED
- 2 USB Port (transfer files to and from memory stick)
- 3 Six Front Panel Softkeys
- 4 Channel 1 Output Connector
- 5 Channel 1 On/Off Switch
- 6 Channel 2 On/Off Switch
- 7 Channel 2 Output Connector

## The Rear Panel at a Glance

The rear panel of the amplifier is shown below.

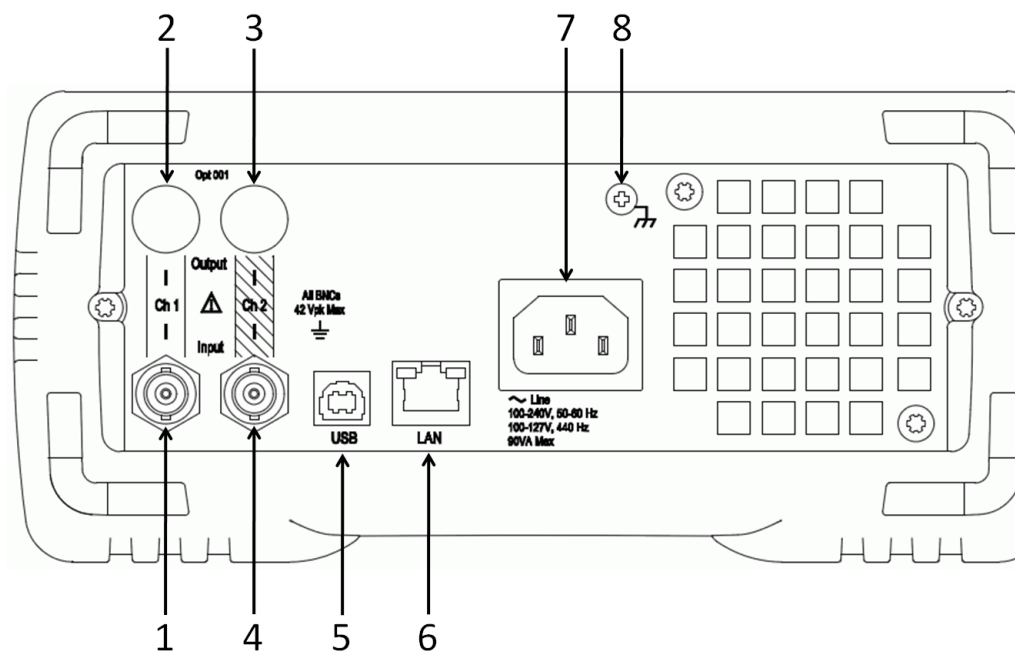

- 1 Channel 1 Input Connector
- 2 Channel 1 Output Connector (Option 001 only)
- 3 Channel 2 Output Connector (Option 001 only)
- 4 Channel 2 Input Connector
- 5 USB Interface Connector
- 6 LAN Interface Connector
- 7 AC Power Connector
- 8 Chassis Ground Screw

**For protection from electrical shock, the power cord ground must not be defeated.**

## The Display at a Glance

By default, the front panel display shows the amplifier's status. Channel 1 information is shown in yellow, and channel 2 information is shown in green. If the thermal sensor in the amplifier detects a high temperature, the channel goes into overload protection mode, and the channel status is surrounded by a border, as shown on channel 1 below.

Notice the Error annunciator in the upper right corner of the display. This is an example of an annunciator, a short string of text that appears to indicate a specific condition.

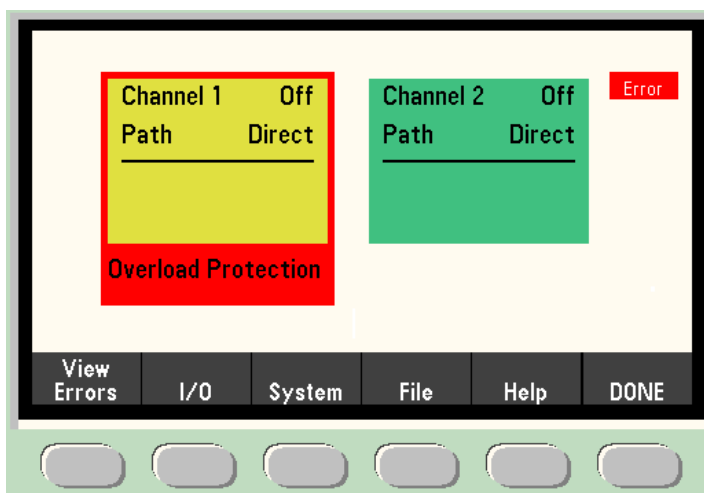

Channel 1 Status	Shown in yellow
Channel 2 Status	Shown in green
Softkey Labels	Shown at the bottom of the screen.

## Basic Amplifier Operations

This section introduces the basics of the 33502A amplifier, and how to use it.

### Preparing the Amplifier for Use

To verify that your 33502A amplifier is ready for use:

**1** Check the list of supplied items.

The following accessories are shipped standard with the 33502A amplifier:

- Power cord for country of destination
- Keysight 33502A Product Reference CD
- Keysight Automation Ready CD (IO Libraries Suite)

All manuals and other documentation are provided in electronic form on the *Keysight 33502A Product Reference CD*.

Before installing the instrument, verify that you have received these items with your instrument. If anything is missing, please contact your nearest Keysight sales office or Keysight authorized reseller .

**2** Inspect the unit.

When you receive your amplifier, inspect it for any obvious damage that may have occurred during shipment. If there is damage, notify the shipping carrier and nearest Keysight sales office or Keysight authorized reseller immediately.

Until you have verified that the amplifier is functional, save the shipping carton and packing materials in case the unit has to be returned.

**3** Connect the power cord and turn on the amplifier.

The front-panel display will light up while the amplifier performs its power-on self-test. The amplifier powers up with DC coupling and 1 MW impedance on both channels.

## Using the Front Panel

The front panel includes two buttons that turn the channels on and off. This is the default configuration, and the amplifier also has an orderable configuration with the output connectors in the back (Option 001).

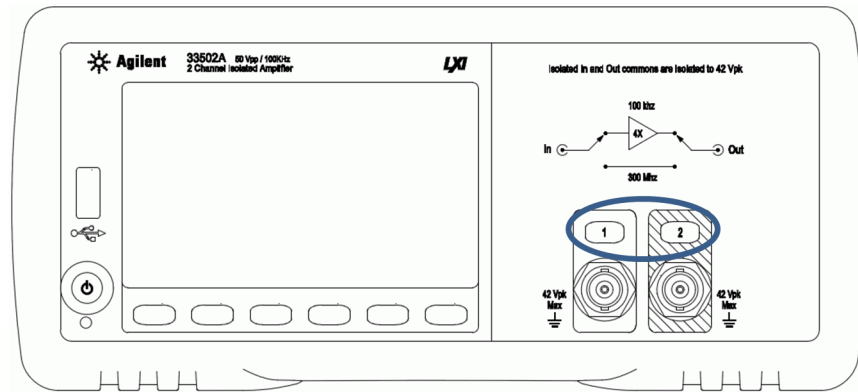

When you turn a channel on, the number on the button illuminates, as shown below for channel 1.

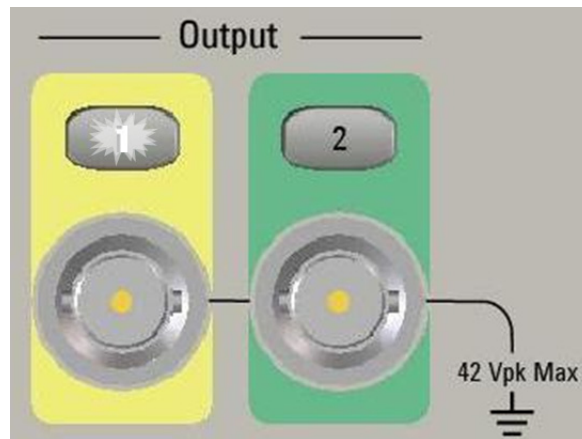

The front panel also includes six softkeys at the bottom of the display that allow you to select various functions and options. Each softkey selects the option shown on the front panel display immediately above the softkey.

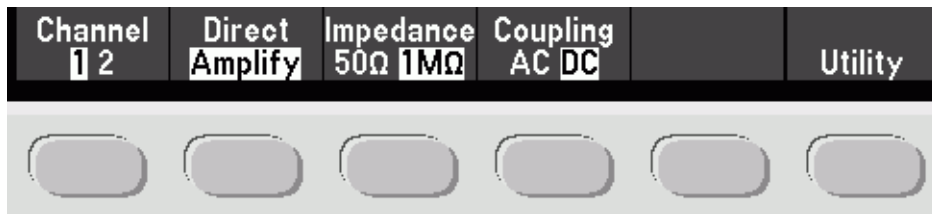

## Basic Amplifier Troubleshooting

This section covers basic troubleshooting and general use.

### If the Amplifier Does Not Turn On

Use the following steps to help solve problems you might encounter when turning on the amplifier. If you need more help, call Keysight support for service. See [Chapter 4](#), “Service Information,” starting on page 44

- 1** Verify that there is AC power to the amplifier.

First, verify that the power cord is firmly plugged into the power module on the rear panel and that the amplifier’s Power switch is in the “On” position. Ensure that the power source the amplifier is plugged into is energized.

- 2** Check whether the LED below the power switch is illuminated.

If it is illuminated and yellow, the amplifier is receiving power and you should try to turn the power on again. When you turn the amplifier on, the LED should be illuminated and green. If the amplifier still does not come up, or if the LED does not light up in the presence of known-good power, your amplifier is in need of repair.

## To Adjust the Carrying Handle

To adjust the position, grasp the handle by the sides and *pull outward*. Then, rotate the handle to the desired position.

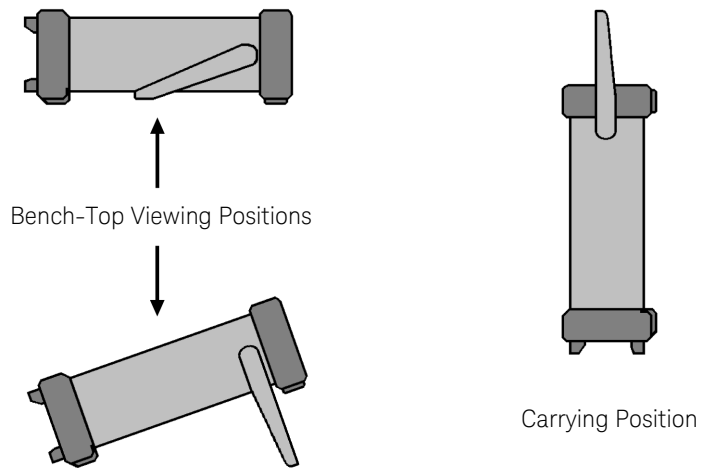

## To Rack Mount the Amplifier

You can mount the 33502A in a standard 19-inch rack cabinet using the available rack-mount kits. Instructions and mounting hardware are included with each kit. Any Keysight System II (half-width, 2U height) instrument of either the 272.3 mm or the 348.3 mm depth can be rack mounted side-by-side with the 33502A. For example, a 33502A and a 33210A, or two 33502As, can be mounted side-by-side, as shown below.

You must remove the carrying handle, and the front and rear rubber bumpers, before rack mounting an instrument.



To remove each bumper, stretch a corner and slide it off.



To remove the handle, rotate it to the vertical position and pull the ends outward.



To rack mount a single amplifier, order adaptor kit 5063-9240

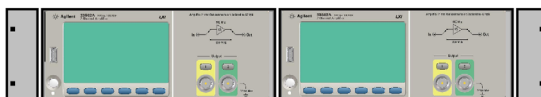

To rack mount two instruments side-by-side, order lock-link kit 5061-6769 and flange kit 5063-9212

## 2 Features and Functions

In this chapter you will find a detailed description of the amplifier's capabilities and operation. This chapter presents both front-panel and remote interface operation of the instrument.

Refer to the *Keysight 33502A Programmer's Reference Help* for a detailed description of the SCPI commands.

SCPI Programming Introduction	18
Front Panel Features	19
Front Panel Display	19
Displayed Messages	19
Front Panel Main Menu	20
Utility Menu	20
File Menu	22
System Menu	23
I/O Config Menu	24
Annunciators	25
Turning the Display Off	25
Front Panel Alphanumeric Character Entry	26
Error Conditions	26
Reading the Error Queue	27
Mass Memory (MMEMory) Subsystem	28
Power-On and Reset State	29

## SCPI Programming Introduction

The Keysight 33502A complies with the syntax rules and conventions of SCPI (*Standard Commands for Programmable Instruments*). For complete SCPI command syntax information, refer to the *Keysight 33502A Programmer's Reference Help*. This is a standard Windows help system, provided on the *Keysight 33502A Product Reference CD-ROM* that came with your instrument.

**SCPI Language Conventions.** Throughout this guide, the following conventions are used for SCPI command syntax for remote interface programming:

- Braces ( { } ) enclose the parameter choices for a given command string. The braces are not sent with the command string.
- A vertical bar ( | ) separates multiple parameter choices for a given command string.
- Triangle brackets ( < > ) indicate that you must specify a value for the enclosed parameter. The brackets are not sent with the command string.
- Some parameters are enclosed in square brackets ( [ ] ). This indicates that the parameter is optional and can be omitted. The brackets are not sent with the command string. If you do not specify a value for an optional parameter, the instrument chooses a default value.

**SCPI Language Version.** You can determine the SCPI version to which your instrument adheres by sending a command from the remote interface.

- You can query the SCPI version from the remote interface only.
- Remote Interface Operation: The SYSTem:VERSion? query returns the SCPI version in the form “YYYY.V”, where “YYYY” represents the year of the version, and “V” represents a version number for that year (for example, 2009.0).

## Front Panel Features

### Front Panel Display

The Keysight 33502A provides an alphanumeric display to indicate the status of the channels and the amplifier's overall configuration. The display also includes a menu section at the bottom that allows you to configure the instrument and perform certain operations.

#### Displayed Messages

The center of the display shows the status of each channel, as shown below.

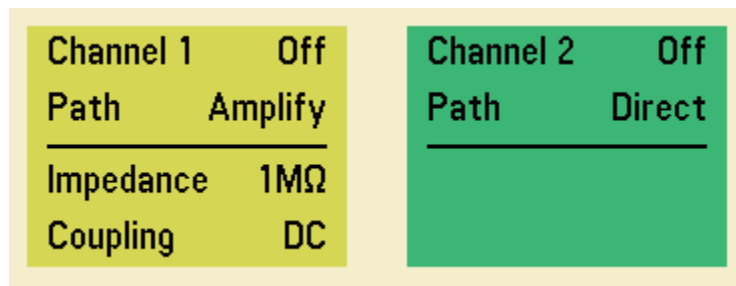

The bottom of the screen is reserved for six softkey labels. Each label describes the function of the softkey immediately below it. A sample menu is shown below.

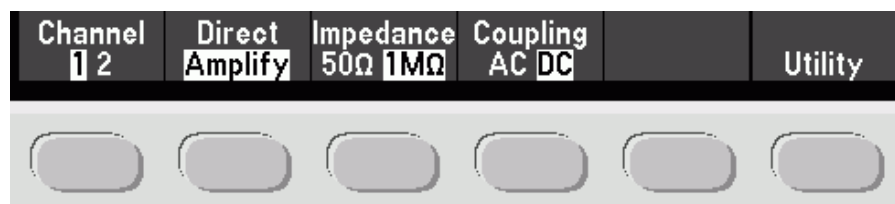

## Front Panel Main Menu

The structure of the main menu is shown below. Four of the buttons allow you to configure the channels, and the rest of the menu options fall under the Utility menu.

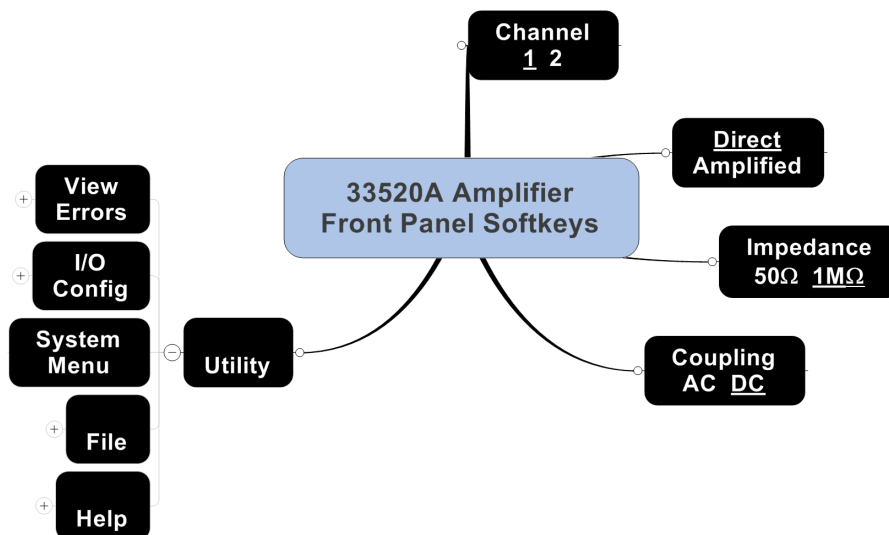

Channel 1 2	Selects the channel to configure.
Direct Amplified	Specifies whether the selected channel should go directly through the 33502A, or whether it should get 5x amplification. If you select Amplify, the Impedance and Coupling softkeys (below) become active.
Impedance 50Ω 1MΩ	Specifies whether the selected channel should have 50 or 1,000,000 ohms of input impedance.
Coupling AC DC	Allows you specify whether the channel should be AC or DC coupled.
Utility	Allows you to configure the instrument, view errors and manipulate files on the mass memory subsystem.

## Utility Menu

The Utility menu is the largest part of the front panel menu system. It is shown in detail below.

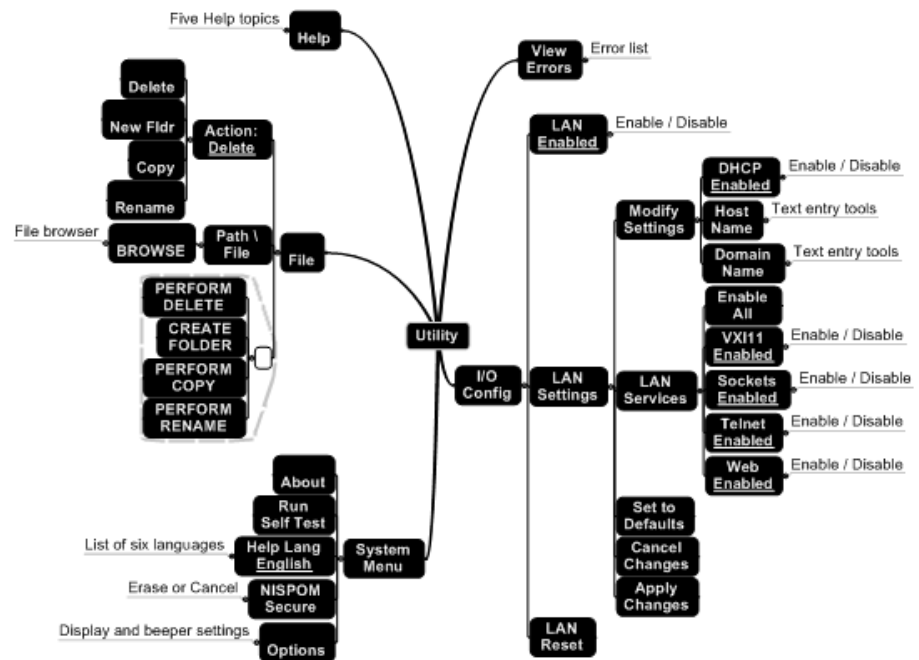

View Errors	Allows you to view the instrument’s error queue. Errors are cleared from the queue as they are displayed on the screen.
I/O Config	Allows you to configure local area network (LAN) settings.
System Menu	Allows you to run a self-test on the amplifier, select the help language, and configure the display and beeper.
File	Allows you to manipulate files and folders in the mass memory subsystem, including internal storage and USB.
Help	Presents a menu of help topics and access to help on the most recently displayed message(s).

### File Menu

The features under the front panel File menu are shown below.

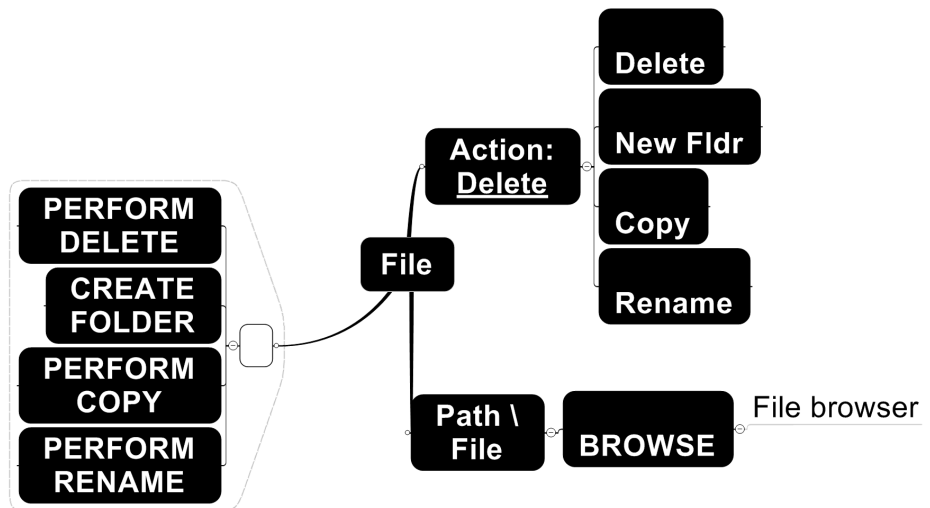

Action	Allows you to specify the action you want to perform. You can create a new folder, and you can also delete, copy or rename a file or folder.
Path \ File	Allows you to specify the file or folder on which you want to perform the action.
(Perform Action)	The label on this softkey will change to one of the four choices shown, depending on what is selected by the Action key above. When you press this softkey, that action will be performed.

## System Menu

The features under the front panel System menu are shown below.

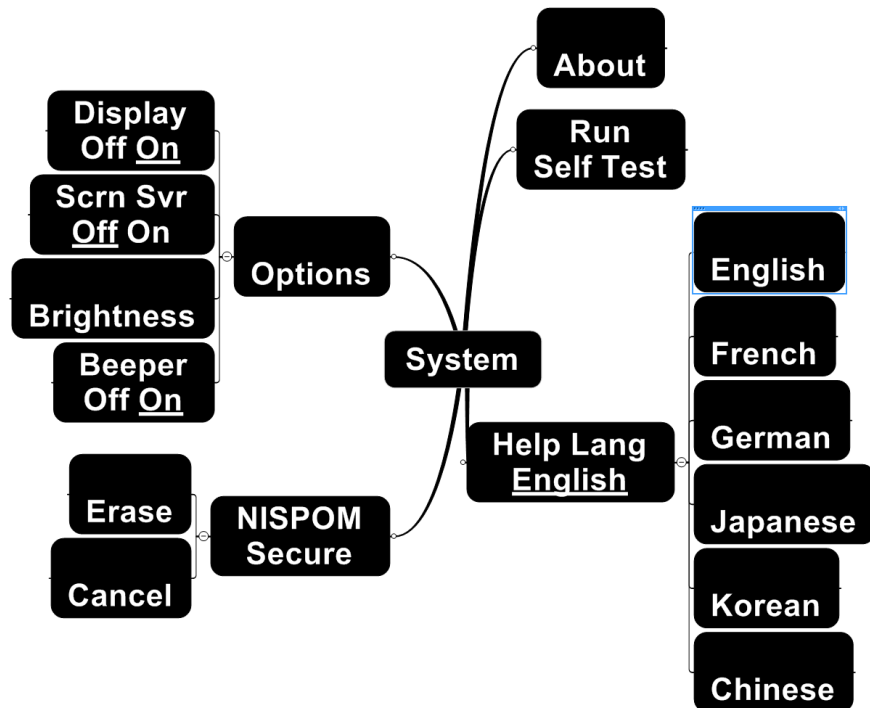

About	Displays information about the amplifier and its firmware.
Run Self Test	Runs a self-test on the amplifier.
Help Lang	Allows you to specify whether you want the help to appear in English, French, German, Japanese, Korean, or Chinese.
NISPOM Secure	Allows you to secure the amplifier to National Industrial Security Program Operating Manual (NISPOM) specifications.
Options	Allows you to configure the display and beeper.

## I/O Config Menu

The features under the front panel I/O Config menu are shown below.

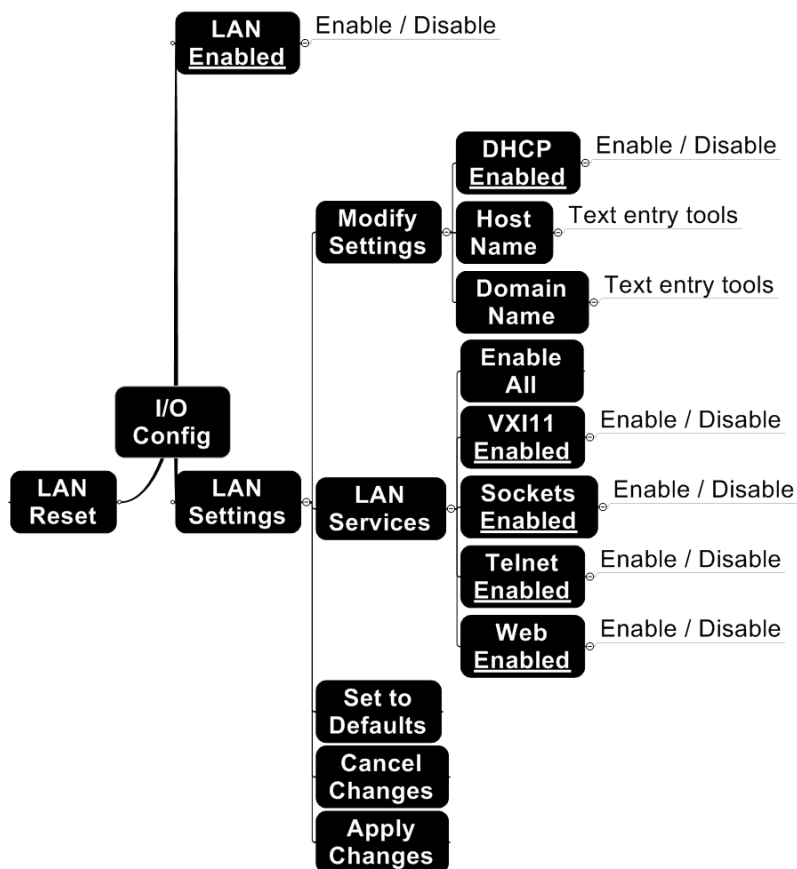

LAN	Enables or disables the amplifier's LAN connection.
LAN Settings	Allows you to configure the amplifier's local area network (LAN) settings.
LAN Reset	Resets the amplifier's LAN settings to factory defaults and resets the connection.

## Annunciators

There are two annunciators on the amplifier's front panel.

- RMT - The amplifier is operating in the remote interface mode. Pressing any softkey or the two channel enable keys will bring the instrument back to local mode unless a remote local lockout or SYSTem:LOCK command has been issued.
- Error - A hardware error or remote interface error has been detected, and a message is in the error queue.

## Turning the Display Off

For security reasons, you may want to disable the front panel display. When disabled, the entire front panel display goes dark. Pressing any key will re-enable the display.

- Front Panel: Press Utility > System > Options > Display Off/On to turn the display off. Press any softkey to turn it back on.
- Remote Interface Operation: The following command turns off the display:  
`DISPlay OFF`

The following command queries the display setting:

```
DISPlay?
```

The query returns 0 (OFF) or 1 (ON).

Sending a DISPlay:TEXT "*<string>*" command when the display is turned off will keep the display off with the exception of displaying the "*<string>*".

## Front Panel Alphanumeric Character Entry

In some menus, such as I/O configuration, you can manually enter a number or alphanumeric string. Use the softkeys shown below to edit the text.

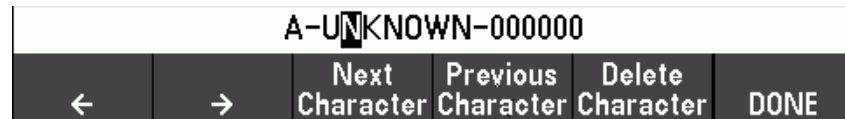

←	Moves the cursor one character to the left, in this case from the N to the U.
→	Moves the cursor one character to the right, in this case from the N to the K.
Next Character	Changes the selected character to the next character in the list of characters. In this case, it would change the N to O.
Previous Character	Changes the selected character to the next character in the list of characters. In this case, it would change the N to M.
Delete Character	Deletes the selected character. In this case, it would delete the N and bring the K next to the U.
DONE	Finishes text editing.

## Error Conditions

When the front panel ERROR annunciator turns on, one or more command syntax or hardware errors have been detected. A record of up to 20 errors can be stored in the instrument's *error queue*.

- The amplifier displays a message and beeps once each time a command syntax or hardware error is generated.
- Each remote interface I/O session (USB or LAN) has its own interface-specific error queue.
- A special *global* error queue holds all power-on and hardware-related errors (for example, over-temperature).
- Errors are retrieved in first-in-first-out (FIFO) order. The first error returned is the first error that was stored. Errors are cleared as you read them. Once you have read all of the interface-specific errors, the errors in the global queue are retrieved.
- Errors are cleared as you read them. When you have read all errors from the interface-specific and global error queues, the ERROR annunciator turns off and the errors are cleared.

- If more than 20 errors have occurred, the last error stored in the queue (the most recent error) is replaced with:  
-350, "Error queue overflow"  
No additional errors are stored until you remove errors from the queue. If no errors have occurred when you read the error queue, the instrument responds with:  
+0, "No error"
- The front panel reports errors from all I/O sessions as well as the global error queue.
- Both the interface-specific and global error queues are cleared by the \*CLS (Clear Status) command and when power is cycled. The errors are also cleared when you read the error queue. The error queue is not cleared by a Factory Reset (\*RST) command or an Instrument Preset (SYSTem:PRESet) command.

### Reading the Error Queue

You can read the error queue either from the front panel, or from the remote interface.

- Front Panel Operation: Press:

UTILITY > VIEW ERRORS

Scroll through the errors using up and down arrows, and then press DONE to finish.

Remote Interface Operation: The following command reads and clears one error from the error queue in first-in, first-out order.

SYSTem:ERRor?

Refer to the *Keysight 33502A Programmer's Reference Help* for a complete description and syntax for this command.

## Mass Memory (MMEMory) Subsystem

The 33502A amplifier includes a mass memory subsystem that allows you to manipulate files and folders on the amplifier's internal memory or on a USB stick attached to the front of the amplifier. The most common use of the mass memory subsystem is to document attributes of the amplifier. For example, you may choose to store a file on the 33502A that lists the tests that use the amplifier, which signals are attached to which channels, and the configured state of each channel.

The SCPI commands used on the mass memory subsystem are all under the MMEMory node. Specifically, the mass memory subsystem uses the following commands:

```
MMEMory:CATalog[:ALL]? [<folder>]
MMEMory:CDIRectory <folder>
MMEMory:COpy <file1>,<file2>
MMEMory:DElete <filename>
MMEMory:DOWNload:DATA <data>
MMEMory:DOWNload:FNAME <filename>
MMEMory:MDIRectory <folder>
MMEMory:MOVE <file1>,<file2>
MMEMory:RDIRectory <folder>
MMEMory:UPLoad? <filename>
```

See the *Keysight 33502A Programmer's Reference Help* for details on these commands.

## Power-On and Reset State

The following tables show the factory default settings.

Channel Configuration	Factory Setting
Coupling	DC
Impedance	1,000,000 ohms
Output State	OFF
Path	AMPLifier

System-Related Operations	Factory Setting
Beeper State	ON
Display State	ON
Error Queue	Cleared at Power-On. <u>Not cleared</u> by a front panel or remote interface Reset command
Mass Memory Folder	INTernal
System Version	2009.0

Input/Output Configuration	Factory Setting
Enable Interfaces: <sup>1</sup>	
LAN	Enabled
USB	Enabled
LXI Identification State	OFF
LAN Settings: <sup>2</sup>	
DHCP	ON
IP Address	169.254.5.2
Default Gateway	0.0.0.0
DNS Server	0.0.0.0
Host Name	A-33502A- <i>nnnnn</i> <sup>3</sup>
LAN Services <sup>1</sup>	Enable All
Telnet Prompt	"33502A>"

## 2 Features and Functions

Input/Output Configuration	Factory Setting
Telnet Welcome Message	"Welcome to Keysight 33502A 2-Channel Isolated Amplifier"

- 1 Interface enable or LAN service changes take effect only after you cycle power.
- 2 LAN setting changes require a LAN restart. From SCPI you must cycle power.
- 3 Where *nnnn* represents the last 5 digits of the instrument serial number.

# 3 Remote Interface Configuration

This chapter describes how to connect the amplifier using a remote interface.

Configuring the USB Interface	33
Configuring the LAN Interface	34
Configuring LAN Parameters	34
DHCP	34
IP Address	35
Subnet Mask	35
Default Gateway	36
Host Name	37
DNS Server	38
Instrument Unexpectedly Goes into Remote	38
Setting up a LAN connection from the Front Panel	39
Setting up a LAN connection from the Remote Interface	40
Keysight 33502A Web Interface	41

This chapter tells how to configure the Keysight 33502A for remote interface communication. For additional information, refer to the:

- *Keysight 33502A Programmer's Reference Help* for information on programming the instrument using SCPI commands. This help file is found on the *Keysight 33502A Product Reference CD-ROM*.

The Keysight 33502A supports USB and LAN interfaces. Both interfaces are enabled at power on. The front panel Remote annunciator turns on whenever there is activity on the remote interface.

- **USB Interface** - There is nothing to configure on your instrument for a USB connection. Just connect the amplifier to your PC using the USB 2.0 cable included with the instrument. Be sure to use the USB port on the amplifier's rear panel for USB connectivity; the USB port on the front panel is for a USB drive.
- **LAN Interface** - By default, DHCP is enabled on the instrument, which may enable network communication over the LAN interface (10BaseT/100BaseTx). You may need to set several configuration parameters as described in the LAN configuration sections that follow.

#### NOTE

To configure and verify an interface connection between the 33502A and your PC, use the Keysight IO Libraries Suite (E2094M Keysight IO Libraries for Windows) or an equivalent. For more information about Keysight's I/O connectivity software, go to:

[www.keysight.com/find/iolib](http://www.keysight.com/find/iolib)

---

## Configuring the USB Interface

For the USB interface, no configuration parameters are *required* to set up the amplifier. Connect the USB port on the rear panel of your amplifier to a USB port on your computer. Note that it may take several seconds for the computer to recognize and establish a connection to the amplifier.

- Remote Interface Operation: The following command enables the USB remote interface:

```
SYSTem:COMMunicate:ENABle ON,USB
```

The following command queries the state of the USB interface:

```
SYSTem:COMMunicate:ENABle? USB
```

This query returns a “0” (disabled) or a “1” (enabled).

Refer to the *Keysight 33502A Programmer’s Reference Help* for complete description and syntax for these commands.

## Configuring the LAN Interface

By default, LAN connectivity with DHCP (Dynamic Host Configuration Protocol) is enabled on the 33502A. In many cases you can simply let DHCP assign the necessary parameters for a LAN connection. However, you can also turn off DHCP and set parameters manually.

**LAN Parameters** You may manually set the following parameters, as described in the subsections that follow. Following these descriptions are procedures for setting up a LAN configuration from the front panel and the remote interface.

- IP Address (the address to enter to start the Web UI or to identify the amplifier in the Keysight IO Libraries instrument setup menu)
- Subnet Mask
- Default Gateway
- DNS Server
- Host Name
- LAN Services (Visa LAN, Sockets, Telnet, Keysight Web Server)

### NOTE

The IP Address, Subnet Mask, Default Gateway, and DNS Server parameters use “dot-notation” addresses. Dot-notation addresses (“nnn.nnn.nnn.nnn” where “nnn” is a byte value) must be expressed with care:

Most computers interpret byte values with leading zeros as octal numbers. For example, “255.255.020.011” is actually equivalent to decimal “255.255.16.9” not “255.255.20.11” because the computer will interpret “.020” as “16” expressed in octal, and “.011” as “9”.

However, the amplifier assumes that all dot-notation addresses are expressed as decimal byte values and strips all leading zeros from these byte values. Thus, attempting to set an IP address of “255.255.020.011” will become “255.255.20.11” (a purely decimal expression). Be sure to enter the exact expression, “255.255.20.11”, in your computer web software to address the instrument. To avoid confusion, use only decimal expressions of byte values (0 to 255), with no leading zeros.

## Configuring LAN Parameters

### DHCP

DHCP is a protocol for automatically assigning a dynamic IP address, subnet mask, and default gateway to a device on a network, and is typically the *easiest* way to configure your amplifier for remote communication using the LAN interface.

- Changing the DHCP setting will cause an automatic LAN restart.
- When DHCP is *enabled* (factory setting), the amplifier will try to obtain an IP address from a DHCP server. If a DHCP server is found, it will assign a dynamic IP address, subnet mask, and default gateway to the instrument. The DHCP server may also assign the DNS address, and may change the specified host name if a manually specified host name is already in use.
- When DHCP is *disabled* or unavailable, the amplifier will use the static IP address, Subnet Mask, and Default Gateway during power-on.
- If a DHCP LAN address is *not* assigned by a DHCP server, then a static IP will be assumed after approximately 1 minute.
- If Auto-IP is enabled, a *dynamic* (rather than static) IP address will be assigned by the server at power-on.

### IP Address

An Internet Protocol (IP) Address is required for all IP and TCP/IP communications with the instrument. If DHCP is enabled (factory setting), the specified static IP address is not used. However, if the DHCP server fails to assign a valid IP address, *or* if DHCP and Auto-IP are *both* off, the currently configured static IP address will be used.

- Changing the IP address will cause an automatic LAN reset.
- The factory-set default IP Address is “169.254.5.2”.
- If you are planning to use a static IP address on a corporate LAN, contact your network administrator to obtain a fixed IP address to be used exclusively for your instrument.
- The IP address is stored in non-volatile memory, and does not change when power has been off, after a Factory Reset (\*RST) command, or after an Instrument Preset (SYSTem:PRESet) command.

### Subnet Mask

The amplifier uses the Subnet Mask to determine whether a client IP address is on the same local subnet. When a client IP address is on a different subnet, all packets must be sent to the Default Gateway. Contact your network administrator to determine whether subnetting is being used and for the correct Subnet Mask.

- Changing the Subnet Mask setting will cause an automatic LAN reset.
- The default Subnet Mask for the 33502A amplifier is “255.255.0.0”.
- A value of “0.0.0.0” or “255.255.255.255” indicates that subnetting is not being used.
- The Subnet Mask is stored in non-volatile memory, and does not change when power has been off, after a Factory Reset (\*RST) command, or after an Instrument Preset (SYSTem:PRESet) command.

#### Default Gateway

A Default Gateway address allows the amplifier to communicate with systems that are not on the local subnet. Thus, this is the Default Gateway where packets are sent which are destined for a device not on the local subnet, as determined by the Subnet Mask setting. Contact your network administrator to determine if a gateway is being used and for the correct address.

- Changing the Default Gateway setting will cause an automatic LAN reset.
- The default for the amplifier is “0.0.0.0” (no gateway, and subnetting is not being used).
- The Default Gateway is stored in non-volatile memory, and does not change when power has been off, after a Factory Reset (\*RST) command, or after an Instrument Preset (SYSTem:PRESet) command.

## Host Name

The Host Name is the host portion of the domain name, which is translated into an IP address.

- Changing the Host Name will cause an automatic LAN reset.
- The default Host Name for the amplifier is “A-33502A-*nnnnn*”, where *nnnnn* is the last five digits of the instrument’s serial number representation.
- If Dynamic Domain Name System (DNS) is available on your network and your amplifier uses DHCP, the Host Name is registered with the Dynamic DNS service at power-on.
- The Host Name is stored in non-volatile memory, and does not change when power has been off, after a Factory Reset (\*RST) command, or after an Instrument Preset (SYSTem:PRESet) command.

#### **DNS Server**

The Domain Name Service (DNS) is an Internet service that translates Domain names into IP addresses. Contact your network administrator to determine if DNS is being used and for the correct address.

- If you change the DNS address, you must cycle power on the amplifier to activate the new setting.
- The default DNS Address for the amplifier is “0.0.0.0”.
- The DNS Server address is stored in non-volatile memory, and does not change when power has been off, after a Factory Reset (\*RST) command, or after an Instrument Preset (SYSTem:PRESet) command.

#### **Instrument Unexpectedly Goes into Remote**

If your 33502A unexpectedly goes into remote mode, it is likely because you have the instrument configured to the LAN on someone else’s host controller. Operations on that host controller can query your instrument causing it to go into remote mode. To prevent this, do any of the following:

- Disconnect the instrument from the LAN.
- Disable the LAN interface from the front panel (Utility menu).

## Setting up a LAN connection from the Front Panel

To begin setting up a LAN connection, press Utility > I/O > LAN Settings.

### NOTE

If you disable or re-enable the LAN interface, or any of the LAN services, you must cycle the power on the instrument to activate the new configuration. Other settings are activated by a LAN restart when you exit the LAN menu.

- The following submenus are displayed:
  - Modify Settings – Change most LAN settings (described below).
  - LAN Services – Enable or disable VXI-11, Sockets, Telnet or Web. If you disable or re-enable any of the LAN services, you must cycle the power on the instrument for the change to take effect.
  - Set to Defaults – Set LAN Settings back to their factory default settings.
  - Cancel Changes – Cancel settings changes.
  - Apply Changes – Apply settings changes and restart the LAN interface.
  - DONE – Apply settings changes and restart the LAN interface.
- If you choose Modify Settings, there are either three or six softkeys, depending on whether DHCP is enabled.
  - DHCP – Enabled or Disabled
  - Host Name – (Only shown if DHCP is enabled) Change the amplifier's host name. This must be a string of alphanumeric characters plus dashes ("-"), up to 44 characters, with the first character a letter.
  - IP Address – (Only shown if DHCP is disabled) Set IP address in dot notation using softkeys.
  - Subnet Mask – (Only shown if DHCP is disabled) Set subnet mask in dot notation using softkeys.
  - Gateway – (Only shown if DHCP is disabled) Set gateway in dot notation using softkeys.
  - DONE – Return to the previous menu level.
  - MORE – (Only shown if DHCP is disabled) Opens an additional menu that allows you to enter DNS, WINS and host name information.

## Setting up a LAN connection from the Remote Interface

Use the following SCPI commands to configure the LAN interface.

### NOTE

If you disable or re-enable the LAN interface, you must cycle the power for the change to take effect. You must also cycle power when you disable or re-enable any of the LAN services, or change any LAN settings from the remote interface using SCPI commands.

- To enable or disable the LAN remote interface:  
`SYSTem:COMMunicate:ENABle {OFF|0|ON|1}, LAN`
- To enable or disable the use of DHCP for the LAN interface:  
`SYSTem:COMMunicate:LAN:DHCP {OFF|0|ON|1}`
- To assign the LAN a static IP address:  
`SYSTem:COMMunicate:LAN:IPADdress "<address>"`
- To assign a LAN Subnet Mask:  
`SYSTem:COMMunicate:LAN:SMASK "<mask>"`
- To assign a LAN Default Gateway:  
`SYSTem:COMMunicate:LAN:GATEway "<address>"`
- To assign a LAN Host Name:  
`SYSTem:COMMunicate:LAN:HOSTname "<name>"`
- To assign the LAN a static DNS address:  
`SYSTem:COMMunicate:LAN:DNS "<address>"`

Query forms of these commands are also available. Refer to the *Keysight 33502A Programmer's Reference Help* for complete command description and syntax.

## Keysight 33502A Web Interface

The 33502A provides a built-in Web Interface. You can use this interface over LAN for remote access and control of the amplifier using a Java-enabled Web browser, such as Microsoft® Internet Explorer.

*To access and use the 33502A Web Interface:*

- 1** Establish a LAN interface connection from your computer to the amplifier.
- 2** Open your computer's Web browser.
- 3** Launch the 33502A Web Interface by entering the IP address (http://156.140.xxx.yyy) of your amplifier, or its fully-qualified host name (http://myamplifier.location.companyname.com), in the browser address field.
- 4** For further information, click Help with this Page and follow the instructions in the Web Interface Help.

### 3 Remote Interface Configuration

# 4 Service Information and Typical Characteristics

This chapter describes how to verify instrument functionality, how to obtain service, and describes the instrument's typical characteristics.

Service Information	44
Verifying Amplifier Functionality	44
Gain, Flatness, and Full Power Bandwidth Tests	45
Output Current Tests	46
Internal Switching Tests	47
Types of Service Available	48
Extended Service Contracts	48
Obtaining Repair Service (Worldwide)	48
Repackaging for Shipment	49
Cleaning Instructions	49
Replaceable Parts List	50
To Order Replaceable Parts	50
Typical Characteristics	51
General Characteristics	52
Input Configuration	54
Output Configuration	55
Dimensions	56

## Service Information

### Verifying Amplifier Functionality

This simple procedure allows you to verify that your 33502A amplifier is functioning properly. To begin, set up the amplifier in the following configuration, which includes a function generator and a digital multimeter (DMM) connected via shielded BNC cable.

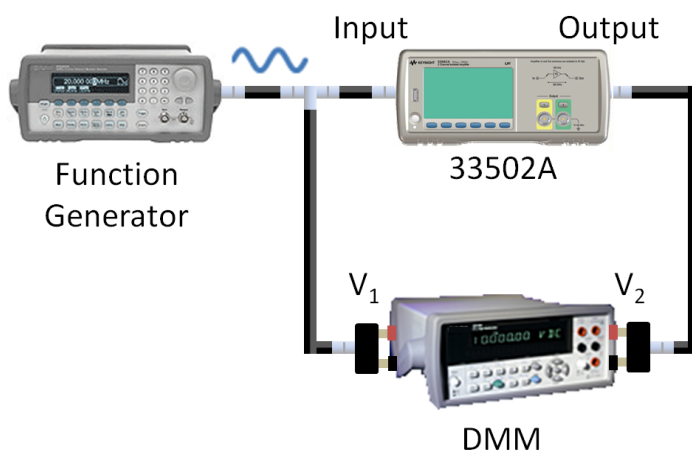

You will use this configuration for each of the tests described in this section.

### Gain, Flatness, and Full Power Bandwidth Tests

- 1 Configure the function generator to generate a sine wave with high impedance load.
- 2 Configure the DMM for AC voltage with 10 Hz bandwidth or less.
- 3 Configure the 33502A for 1 M $\Omega$  input impedance, with the channel turned on and amplified. You will need to repeat the test for both channels.
- 4 For each of the combinations shown in the following table, measure  $V_1$  (the unamplified signal from the function generator) and  $V_2$  (the amplified signal from the 33502A). Calculate  $V_2/V_1$  and record the information in the table shown below.
- 5 Compare your values of  $V_2/V_1$  to the typical values for operation shown in the two columns on the right side of the table.

Coupling	Frequency (Hz)	VRMS (V)	$V_1$	$V_2$	$V_2/V_1$	Typical Low	Typical High
DC	1,000	2				4.995	5.005
AC	1,000	2				4.995	5.005
DC	10	2				4.995	5.005
AC	10	3.5				4.950	5.05
DC	40	3.5				4.950	5.05
DC	100,000	3.5				4.750	5.25

## Output Current Tests

**CAUTION**

To avoid causing a false result by overheating the 33502A, be sure to disconnect the DMM from the amplified output of the 33502A until you are ready to take the measurements. When you do connect to take the measurement, do not stay connected for more than 10 seconds, and disconnect the amplified output from the DMM immediately upon taking the measurement by turning off the output of the 33502A.

---

- 1 Configure the function generator to generate a 1 kHz, 1 VRMS square or sine wave with high impedance load.
- 2 Configure the DMM for AC current.
- 3 Configure the 33502A for 1 M $\Omega$  input impedance, with the channel turned on and amplified. You will need to repeat the test for both channels.
- 4 Connect the output of the amplifier to the DMM for less than 10 seconds and measure the current from the amplifier. Disconnect the amplified output from the DMM by turning off the output of the 33502A.
- 5 The current should typically be between 250 and 480 mA.

## Internal Switching Tests

- 1 Configure the function generator to generate 1 VDC into a high impedance load.
- 2 Configure the DMM for DCV.
- 3 For each of the 33502A configurations shown in the following table, measure  $V_{out}$  (the amplified signal).
- 4 Compare your values of  $V_{out}$  to the typical values for operation shown in the two columns on the right side of the table.

Output	Impedance	Coupling	$V_{out}$	Typical Low	Typical High
Amplify, Off	1 M $\Omega$	DC	0	0.02	
Direct, On	1 M $\Omega$	DC	0.95	1.05	
Amplify, On	1 M $\Omega$	DC	4.75	5.25	
Amplify, On	1 M $\Omega$	AC	0	0.02	
Amplify, On*	50 $\Omega$	DC	2.38	2.63	

\* Skip this test if the DC source does not have 50  $\Omega$  output impedance.

## Types of Service Available

If your instrument fails during the warranty period, Keysight Technologies will repair or replace it under the terms of your warranty. After your warranty expires, Keysight offers repair services at competitive prices.

### Extended Service Contracts

Many Keysight products are available with optional service contracts that extend the *covered period* after the standard warranty expires. If you have such a service contract and your instrument fails during the covered period, Keysight Technologies will repair or replace it in accordance with the contract.

### Obtaining Repair Service (Worldwide)

To obtain service for your instrument (in-warranty, under service contract, or post-warranty), contact your nearest Keysight Technologies Service Center. They will arrange to have your unit repaired or replaced, and can provide warranty or repair-cost information where applicable.

To obtain warranty, service, or technical support information you can contact Keysight Technologies at one of the following telephone numbers:

In the United States: (800) 829-4444

In Europe: 31 20 547 2111

In Japan: 0120-421-345

Or use our Web link for information on contacting Keysight worldwide:

[www.keysight.com/find/assist](http://www.keysight.com/find/assist)

Or contact your Keysight Technologies representative.

Before shipping your instrument, ask the Keysight Technologies Service Center to provide shipping instructions, including what components to ship. Keysight recommends that you retain the original shipping carton for use in such shipments.

## Repackaging for Shipment

If the unit is to be shipped to Keysight for service or repair, be sure to:

- Attach a tag to the unit identifying the owner and indicating the required service or repair. Include the model number and full serial number.
- Place the unit in its original container with appropriate packaging material for shipping.
- Secure the container with strong tape or metal bands.

If the original shipping container is not available, place your unit in a container which will ensure at least 4 inches of compressible packaging material around all sides for the instrument. Use static-free packaging materials to avoid additional damage to your unit.

Keysight suggests that you always insure shipments.

## Cleaning Instructions

Before cleaning the amplifier, remove power from the amplifier. Clean the outside of the instrument with a soft, lint-free, slightly dampened cloth. Do not use detergent. Disassembly is not required or recommended for cleaning. Be sure that the amplifier is dry before restoring power.

## Replaceable Parts List

This section contains information for ordering replacement parts for your instrument. The parts lists include a brief description of each part with the applicable Keysight part number.

No operator serviceable parts inside; refer servicing to service trained personnel.

### To Order Replaceable Parts

You can order replaceable parts from Keysight using the Keysight part number. To order replaceable parts from Keysight:

- Contact your nearest Keysight Sales Office or Service Center.
- Identify the parts by the Keysight part number shown below.
- Provide the instrument model number and serial number.

Part Number	Description
34401-86020	Bumper Kit
34401-45021	Handle
33220-84101	Cover
33502-88001	Keypad
2090-0977	Display
1250-2110	Front Panel BNCs
33502-80001	Front Panel Kit
33502-66502	Front Panel PCA
1252-8483	USB Connector
1253-4669	LAN Connector
53200-61608	Line Filter
33250-68501	Fan
33502-80002	Power Supply Kit*

\* The fuses used in the power supply are 3.15A / 250V radial-leaded, time lag fuses. If the fuse blows, replace the entire power supply assembly.

## Typical Characteristics

These characteristics apply when using the 33502A amplifier in an environment that is *free* of electromagnetic interference and electrostatic charge.

When using the amplifier in an environment where electromagnetic interference or significant electrostatic charge *is* present, measurement accuracy may be reduced.

*Specifications are subject to change without notice.* For the latest specifications, see the product datasheet on the Web. Firmware updates may also be available on the Web. Start at the product page:

[www.keysight.com/find/33502A](http://www.keysight.com/find/33502A)

*This ISM device complies with Canadian ICES-001.  
Cet appareil ISM est conforme à la norme NMB-001  
du Canada.*



## General Characteristics

Power Supply:	100V/120V/ 220V / 240V $\pm$ 10%
Power Line Frequency:	50–60 Hz $\pm$ 10%, 400 Hz $\pm$ 10%. Automatically sensed at power-on, 400 Hz defaults to 50Hz.
Power Consumption:	100 VA peak (typical value depends on configuration and load)
Operating Environment:	Full accuracy for 0 °C to 55 °C Full accuracy to 80% R.H. at 40°C Non-condensing
Storage Temperature:	–30 °C to 70 °C
Operating Altitude:	Up to 3000m
Bench Dimensions (WxHxD):	261.2mm x 103.8mm x 303.2mm
Weight:	3.1 kg (6.8 lbs)
EMC Tested to:	Complies with European EMC Directive for test and measurement products. <ul style="list-style-type: none"> <li>● IEC/EN 61326-1</li> <li>● CISPR Pub 11 Group 1, class A</li> <li>● AS/NZS CISPR 11</li> <li>● ICES/NMB-001</li> </ul> Complies with Australian standard and carries C-Tick mark. This ISM device complies with Canadian ICES-001. Cet appareil ISM est conforme à la norme NMB-001 du Canada.
Safety:	Complies with European Low Voltage Directive and carries the CE-marking. Conforms to UL 61010-1, CSA C22.2 61010-1, and IEC 61010-1:2001.
Acoustic Noise:	Normal operating mode SPL 35 dB(A)

Display:	4.3" Color TFT WQVGA (480x272), LED backlight
Remote Interfaces:	10/100Mbit LAN USB 2.0 Standard
Language:	SCPI – 1994.0 IEEE–488.2
LXI Compliance:	LXI Class C, Version 1.0
Number of Channels:	2
Channel to Channel Ground Connection:	Not connected in BYPASS ON. Connected with both channels OFF or in Gain of 5x
Floating Voltage:	$\pm 42$ Vpk to earth

## Input Configuration

Input Coupling:	
AC Coupling	Programmable
DC Coupling	Default, Programmable
Input Impedance	
1M $\Omega$	Default, Programmable
50 $\Omega$	Programmable
Input Voltage Range	
Maximum Voltage Range	$\pm 5$ Vpk for gain of 5X $\pm 30$ Vpk for bypass
Damage Level	$\pm 10$ Vpk for 50 $\Omega$ input $\pm 35$ Vpk for 1 M $\Omega$ input
Input Path	Programmable gain of 5x, bypass (1x), or off state
Input Gain 5X	5x, Fixed, Non-Inverting.
Gain Accuracy <sup>2</sup>	$\pm 0.1\%$ @ 1kHz
Flatness DC coupling <sup>1</sup>	0.1% : DC - 10 kHz 1% : DC - 40 kHz 5% : DC - 100 kHz
Flatness AC coupling <sup>1</sup>	0.1% : 30Hz - 10 kHz 1% : 10Hz - 40 kHz 5% : 3Hz - 100 kHz
Small Signal Bandwidth <sup>1</sup>	> 300 kHz (-3dB)
Full Power Bandwidth <sup>1</sup>	100 kHz @ 50 Vpp output
Input Bypass	
Bandwidth for 50 $\Omega$ system	> 300 MHz (-3dB)
Maximum current	0.2 A <sub>pk</sub>
Noise	
Input referred noise	< 40nV/ rt-Hz @ 1 kHz

## Output Configuration

Output Current	200 mA. (150 mA for continuous output from -8 V to +8 V)
DC Output Resistance	< 2 $\Omega$
Max Output Level <sup>1</sup>	$\pm 25$ Vpk
Output DC Offset	< 10 mV
Output Slew Rate	> 20 V/ $\mu$ s
THD + N <sup>1</sup>	< 0.01% @ 10 kHz, 40 Vpp
Aberrations (overshoot/undershoot) <sup>1</sup>	< 5% for waveforms with < 3 V input step or non-slewing output
Transition time <sup>1</sup> (Final value $\pm 1\%$ of step size)	2.5 $\mu$ s + 50 ns/V of output step
Channel to channel isolation for gains of 5x	> 75 dB
Capacitive load for no oscillation	< 1 nF
Output Protection	Continuous short circuit protection. Thermal overload shutdown. Over temperature status flag.

<sup>1</sup>For all loads >250  $\Omega$  and <400 pF of capacitance.

<sup>2</sup>Measured with  $\geq 1$  M $\Omega$  load and 1 M $\Omega$  input selection.

## Dimensions

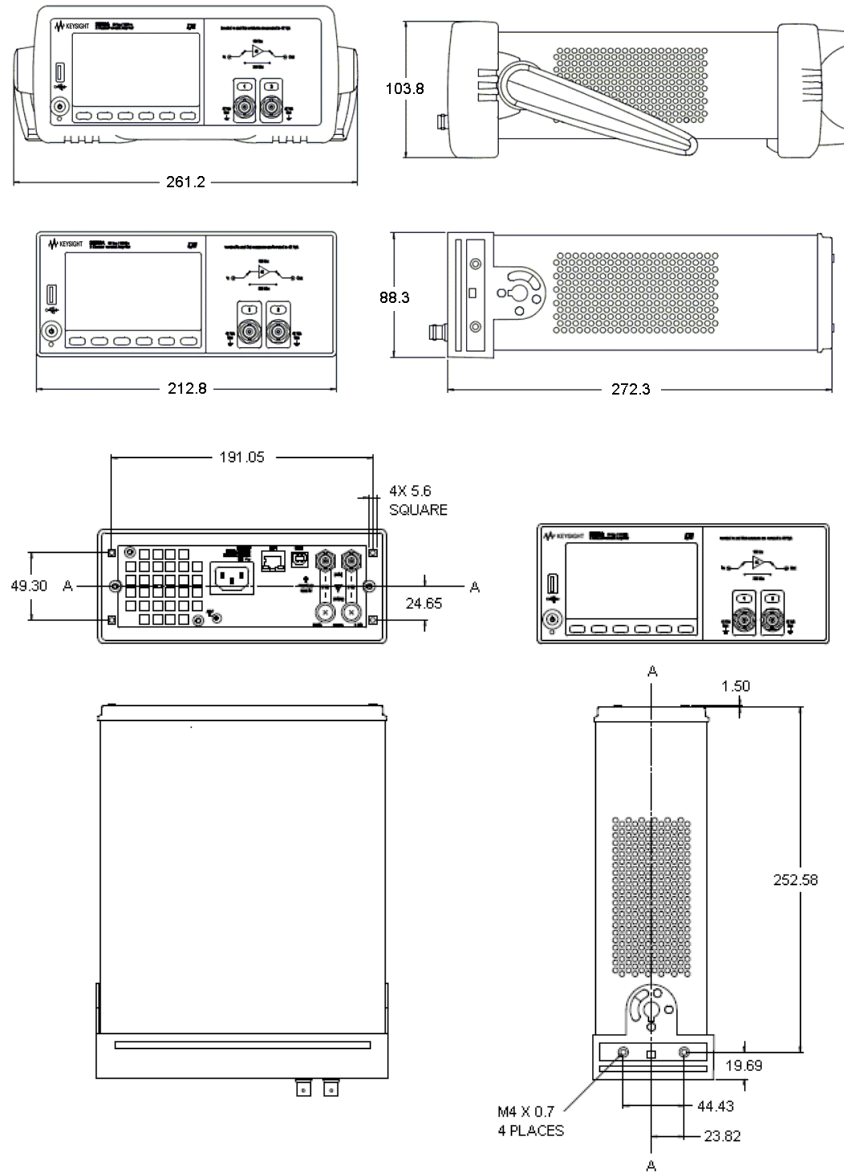

All dimensions are shown in millimeters

# Index

## A

Amplifier  
 Failure to Turn On, 14  
 Amplifier  
 Preparing for Use, 11  
 Rack Mounting, 16  
 Supplied Items, 11  
 Annunciators, 25

## B

Bumper Removal, 16

## C

Carry Handle, 15  
 Changing Digits Displayed, 26  
 Character Entry, 26  
 Configuring  
 LAN, 34  
 USB, 33  
 Connectors on Rear Panel, 8, 9

## D

Default Gateway, 34, 36  
 Default Settings, 29  
 DHCP, 34  
 Display, 19  
 Character Entry, 26  
 Turn Off, 25  
 Display Annunciators, 25  
 DNS Server, 34, 38

## E

Error Conditions, 26  
 Errors  
 reading, 27

## F

Factory Settings, 29  
 Front Panel Display, 19

## H

Host Name, 34, 37

## I

IP Address, 34

## K

Keysight Web Server, 34

## L

LAN Interface, 32, 34  
 LAN Services, 34

## M

Menu  
 Utility, 20  
 Messages Displayed, 19

## P

Power On State, 29  
 Prepare for Use, 11

## R

Rack Mounting, 16  
 Rear Panel Description, 8, 9  
 Remote Annunciator, 32  
 Remote I/O  
 introduction, 32  
 unexpected, 38  
 Remote Interface  
 Configuration, 32  
 Rubber Bumper Removal, 16

## S

Safety Information, 3  
 Safety Symbols, 3  
 SCPI  
 Language Conventions, 18  
 Language Version, 18  
 Service Information, 44  
 Settings  
 Default, 29  
 Sockets, 34  
 Subnet Mask, 34  
 System II Rack Mounts, 16

## T

TCP/IP, 35  
 Telnet, 34  
 Troubleshooting, 14  
 Turn Off Display, 25

## U

USB Interface, 32, 33  
 Utility Menu, 20

## V

Visa LAN, 34

## W

Waste Electrical and Electronic  
 Equipment Directive, 4  
 Web Browser, 41



This information is subject to change without notice. Always refer to the Keysight Web site for the latest revision.

© Keysight Technologies 2009 - 2020  
Edition 4, April 8, 2020

Printed in Malaysia



33502-90001

[www.keysight.com](http://www.keysight.com)