

1:10 LOW JITTER UNIVERSAL BUFFER/LEVEL TRANSLATOR WITH 2:1 INPUT MUX

Features

- 10 differential or 20 LVCMOS outputs
- Ultra-low additive jitter: 45 fs rms
- Wide frequency range: 1 to 725 MHz
- Any-format input with pin selectable output formats: LVPECL, Low Power LVPECL, LVDS, CML, HCSL, LVCMOS
- 2:1 clock input mux
- Glitchless input clock switching
- Synchronous output enable
- Output clock division: /1, /2, /4
- Independent V_{DD} and V_{DDO} : 1.8/2.5/3.3 V
- Excellent power supply noise rejection (PSRR)
- Selectable LVCMOS drive strength to tailor jitter and EMI performance
- Loss of signal (LOS) monitors for loss of input clock
- Small size: 44-QFN (7 mm x 7 mm)
- RoHS compliant, Pb-free
- Industrial temperature range: -40 to +85 °C



Applications

- High-speed clock distribution
- Ethernet switch/router
- Optical Transport Network (OTN)
- SONET/SDH
- PCI Express Gen 1/2/3
- Storage
- Telecom
- Industrial
- Servers
- Backplane clock distribution

Description

The Si53302 is an ultra low jitter ten output differential buffer with pin-selectable output clock signal format and divider selection. The Si53302 features a 2:1 mux with glitchless switching, making it ideal for redundant clocking applications. The Si53302 utilizes Silicon Laboratories' advanced CMOS technology to fanout clocks from 1 to 725 MHz with guaranteed low additive jitter, low skew, and low propagation delay variability. The Si53302 features minimal cross-talk and provides superior supply noise rejection, simplifying low jitter clock distribution in noisy environments. Independent core and output bank supply pins provide integrated level translation without the need for external circuitry.

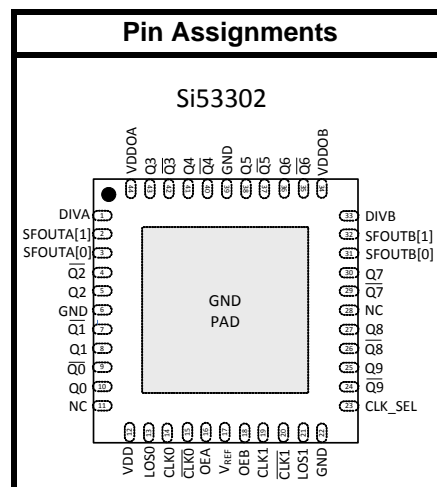

Patents pending

Functional Block Diagram

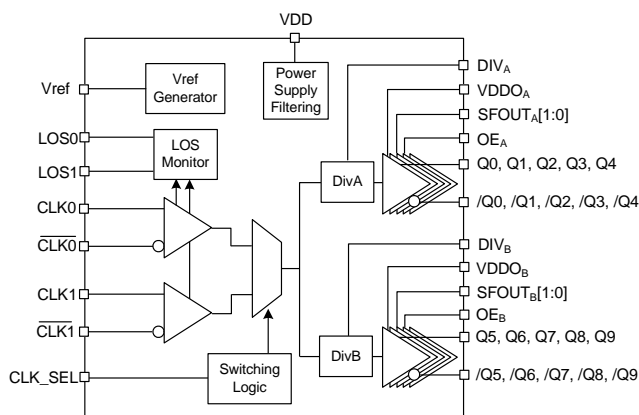

TABLE OF CONTENTS

<u>Section</u>	<u>Page</u>
1. Electrical Specifications	4
2. Functional Description	12
2.1. Universal, Any-Format Input	12
2.2. Input Bias Resistors	14
2.3. Universal, Any-Format Output Buffer	14
2.4. Glitchless Clock Input Switching	15
2.5. Synchronous Output Enable	15
2.6. Loss of Signal (LOS) Indicator	15
2.7. Flexible Output Divider	16
2.8. Input Mux and Output Enable Logic	16
2.9. Power Supply (V_{DD} and V_{DDOX})	16
2.10. Output Clock Termination Options	17
2.11. AC Timing Waveforms	20
2.12. Typical Phase Noise Performance	21
2.13. Input Mux Noise Isolation	24
2.14. Power Supply Noise Rejection	24
3. Pin Description: 44-Pin QFN	25
4. Ordering Guide	28
5. Package Outline	29
5.1. 7x7 mm 44-QFN Package Diagram	29
6. PCB Land Pattern	31
6.1. 7x7 mm 44-QFN Package Land Pattern	31
7. Top Marking	32
7.1. Si53302 Top Marking	32
7.2. Top Marking Explanation	32
Document Change List	33
Contact Information	34

1. Electrical Specifications

Table 1. Recommended Operating Conditions

Parameter	Symbol	Test Condition	Min	Typ	Max	Unit
Ambient Operating Temperature	T_A		-40	—	85	°C
Supply Voltage Range*	V_{DD}	LVDS, CML	1.71	1.8	1.89	V
			2.38	2.5	2.63	V
			2.97	3.3	3.63	V
		LVPECL, low power LVPECL, LVCMOS	2.38	2.5	2.63	V
			2.97	3.3	3.63	V
		HCSL	2.97	3.3	3.63	V
Output Buffer Supply Voltage*	V_{DDOX}	LVDS, CML	1.71	1.8	1.89	V
			2.38	2.5	2.63	V
			2.97	3.3	3.63	V
		LVPECL, low power LVPECL, LVCMOS	2.38	2.5	2.63	V
			2.97	3.3	3.63	V
		HCSL	2.97	3.3	3.63	V

*Note: Core supply V_{DD} and output buffer supplies V_{DDO} are independent.

Table 2. Input Clock Specifications

($V_{DD}=1.8\text{ V} \pm 5\%$, $2.5\text{ V} \pm 5\%$, or $3.3\text{ V} \pm 10\%$, $T_A=-40$ to $85\text{ }^\circ\text{C}$)

Parameter	Symbol	Test Condition	Min	Typ	Max	Unit
Differential Input Common Mode Voltage	V_{CM}	$V_{DD} = 2.5\text{ V} \pm 5\%$, $3.3\text{ V} \pm 10\%$	0.05	—	—	V
Differential Input Swing (peak-to-peak)	V_{IN}		0.2	—	2.2	V
LVCMOS Input High Voltage	V_{IH}	$V_{DD} = 2.5\text{ V} \pm 5\%$, $3.3\text{ V} \pm 10\%$	$V_{DD} \times 0.7$	—	—	V
LVCMOS Input Low Voltage	V_{IL}	$V_{DD} = 2.5\text{ V} \pm 5\%$, $3.3\text{ V} \pm 10\%$	—	—	$V_{DD} \times 0.3$	V
Input Capacitance	C_{IN}	CLK0 and CLK1 pins with respect to GND	—	5	—	pF

Table 3. DC Common Characteristics $(V_{DD} = 1.8\text{ V} \pm 5\%, 2.5\text{ V} \pm 5\%, \text{ or } 3.3\text{ V} \pm 10\%, T_A = -40 \text{ to } 85\text{ }^\circ\text{C})$

Parameter	Symbol	Test Condition	Min	Typ	Max	Unit
Supply Current	I_{DD}		—	65	100	mA
Output Buffer Supply Current (Per Clock Output) @ 100 MHz (diff) @ 200 MHz (CMOS)	I_{DDOX}	LVPECL (3.3 V)	—	35	—	mA
		Low Power LVPECL (3.3 V)*	—	35	—	mA
		LVDS (3.3 V)	—	20	—	mA
		CML (3.3 V)	—	30	—	mA
		HCSL, 100 MHz, 2 pF load (3.3 V)	—	35	—	mA
		CMOS (2.5 V, SFOUT = Open/0), per output, $C_L = 5\text{ pF}$, 200 MHz	—	8	—	mA
CMOS (3.3 V, SFOUT = 0/1), per output, $C_L = 5\text{ pF}$, 200 MHz	—	15	—	mA		
Voltage Reference	V_{REF}	V_{REF} pin	—	$V_{DD}/2$	—	V
Input High Voltage	V_{IH}	SFOUTX, DIVX CLK_SEL, OEX	$0.8 \times V_{DD}$	—	—	V
Input Mid Voltage	V_{IM}	SFOUTX, DIVX 3-level input pins	$0.45 \times V_{DD}$	$0.5 \times V_{DD}$	$0.55 \times V_{DD}$	V
Input Low Voltage	V_{IL}	SFOUTX, DIVX CLK_SEL, OEX	—	—	$0.2 \times V_{DD}$	V
Output Voltage High	V_{OH}	$I_{DD} = -1\text{ mA}$	$0.8 \times V_{DD}$	—	—	V
Output Voltage Low	V_{OL}	$I_{DD} = 1\text{ mA}$	—	—	$0.2 \times V_{DD}$	V
Internal Pull-down Resistor	R_{DOWN}	CLK_SEL, DIVX, SFOUTX	—	25	—	$k\Omega$
Internal Pull-up Resistor	R_{UP}	DIVX, SFOUTX, OEX	—	25	—	$k\Omega$

***Note:** Low-power LVPECL mode supports an output termination scheme that will reduce overall system power.

Table 4. Output Characteristics (LVPECL)

($V_{DD} = V_{DDOX} = 2.5\text{ V} \pm 5\%$, or $3.3\text{ V} \pm 10\%$, $T_A = -40$ to $85\text{ }^\circ\text{C}$)

Parameter	Symbol	Test Condition	Min	Typ	Max	Unit
Output DC Common Mode Voltage	V_{COM}		$V_{DDOX} - 1.595$	—	$V_{DDOX} - 1.245$	V
Single-Ended Output Swing*	V_{SE}		0.55	0.80	1.050	V

***Note:** Unused outputs can be left floating. Do not short unused outputs to ground.

Table 5. Output Characteristics (Low Power LVPECL)

($V_{DD} = V_{DDOX} = 2.5\text{ V} \pm 5\%$, or $3.3\text{ V} \pm 10\%$, $T_A = -40$ to $85\text{ }^\circ\text{C}$)

Parameter	Symbol	Test Condition	Min	Typ	Max	Unit
Output DC Common Mode Voltage	V_{COM}	$R_L = 100\ \Omega$ across Q_n and $\overline{Q_n}$	$V_{DDOX} - 1.895$		$V_{DDOX} - 1.275$	V
Single-Ended Output Swing*	V_{SE}	$R_L = 100\ \Omega$ across Q_n and $\overline{Q_n}$	0.25	0.60	0.85	V

***Note:** $R_L = 100\ \Omega$ across Q_n and $\overline{Q_n}$.

Table 6. Output Characteristics—CML

($V_{DD} = V_{DDOX} = 1.8\text{ V} \pm 5\%$, $2.5\text{ V} \pm 5\%$, or $3.3\text{ V} \pm 10\%$, $T_A = -40$ to $85\text{ }^\circ\text{C}$)

Parameter	Symbol	Test Condition	Min	Typ	Max	Unit
Single-Ended Output Swing	V_{SE}	Terminated as shown in Figure 8 (CML termination).	300	400	500	mV

Table 7. Output Characteristics—LVDS

($V_{DD} = V_{DDOX} = 1.8\text{ V} \pm 5\%$, $2.5\text{ V} \pm 5\%$, or $3.3\text{ V} \pm 10\%$, $T_A = -40$ to $85\text{ }^\circ\text{C}$)

Parameter	Symbol	Test Condition	Min	Typ	Max	Unit
Single-Ended Output Swing	V_{SE}	$R_L = 100\ \Omega$ across Q_N and $\overline{Q_N}$	247	—	454	mV
Output Common Mode Voltage ($V_{DDO}=2.5\text{V}$ or 3.3V)	V_{COM1}	$V_{DDOX} = 2.38$ to 2.63 V , 2.97 to 3.63 V , $R_L = 100\ \Omega$ across Q_N and $\overline{Q_N}$	1.10	1.25	1.35	V
Output Common Mode Voltage ($V_{DDO}=1.8\text{V}$)	V_{COM2}	$V_{DDOX} = 1.71$ to 1.89 V , $R_L = 100\ \Omega$ across Q_N and $\overline{Q_N}$	0.85	0.97	1.10	V

Table 8. Output Characteristics—LVCMOS $(V_{DD} = V_{DDOX} = 2.5 \text{ V} \pm 5\%$, or $3.3 \text{ V} \pm 10\%$, $T_A = -40$ to $85 \text{ }^\circ\text{C}$)

Parameter	Symbol	Test Condition	Min	Typ	Max	Unit
Output Voltage High*	V_{OH}		$0.80 \times V_{DDOX}$	—	—	V
Output Voltage Low*	V_{OL}		—	—	$0.20 \times V_{DDOX}$	V

*Note: I_{OH} and I_{OL} per the Output Signal Format Table for specific V_{DDOX} and SFOUTX settings.

Table 9. Output Characteristics—HCSL $(V_{DD} = V_{DDOX} = 3.3 \text{ V} \pm 10\%$, $T_A = -40$ to $85 \text{ }^\circ\text{C}$)

Parameter	Symbol	Test Condition	Min	Typ	Max	Unit
Output Voltage High	V_{OH}	$R_L = 50 \ \Omega$ to GND	550	700	850	mV
Output Voltage Low	V_{OL}	$R_L = 50 \ \Omega$ to GND	-150	0	150	mV
Single-Ended Output Swing	V_{SE}	$R_L = 50 \ \Omega$ to GND	550	700	850	mV
Crossing Voltage	V_C	$R_L = 50 \ \Omega$ to GND	250	350	550	mV

Table 10. AC Characteristics $(V_{DD} = V_{DDOX} = 1.8 \text{ V} \pm 5\%$, $2.5 \text{ V} \pm 5\%$, or $3.3 \text{ V} \pm 10\%$, $T_A = -40$ to $85 \text{ }^\circ\text{C}$)

Parameter	Symbol	Test Condition	Min	Typ	Max	Unit
LOS Deassertion Time ¹	T_{LOSCLR}	$F < 100 \text{ MHz}$	—	$T_{per}+15$	—	ns
		$F > 100 \text{ MHz}$	—	25	—	ns
LOS Assertion Time ²	T_{LOSACT}		—	15	—	μs
Frequency	F	LVPECL, low power LVPECL, LVDS, CML, HCSL	1	—	725	MHz
		LVCMOS	1	—	200	MHz
Duty Cycle Note: 50% input duty cycle.	D_C	200 MHz, 20/80% $T_R/T_F < 10\%$ of period (LVCMOS) (12 mA drive)	40	50	60	%
		20/80% $T_R/T_F < 10\%$ of period (Differential)	48	50	52	%

Notes:

1. Measured from the initial transition of the corresponding input clock to the falling edge of LOS
2. Measured from the final transition of the corresponding input clock to the rising edge of LOS.
3. When using the on-chip clock divider, a minimum input clock slew rate of 30 mV/ns is required.
4. Measurements were made with receiver termination. See Figure 8 on page 18.
5. Output to Output skew specified for outputs with an identical configuration.
6. Defined as skew between any output on different devices operating at the same supply voltages, temperatures, and equal load conditions. Using the same type of inputs on each device, the outputs are measured at the differential cross points.
7. Measured for 156.25 MHz carrier frequency. Sine-wave noise added to V_{DDOX} ($3.3 \text{ V} = 100 \text{ mV}_{PP}$) and noise spur amplitude measured. See "AN491: Power Supply Rejection for Low-Jitter Clocks" for further details.

Table 10. AC Characteristics (Continued)

($V_{DD} = V_{DDOX} = 1.8\text{ V} \pm 5\%$, $2.5\text{ V} \pm 5\%$, or $3.3\text{ V} \pm 10\%$, $T_A = -40$ to $85\text{ }^\circ\text{C}$)

Parameter	Symbol	Test Condition	Min	Typ	Max	Unit
Minimum Input Clock Slew Rate ³	SR	Required to meet prop delay and additive jitter specifications (20–80%)	0.75	—	—	V/ns
Output Rise/Fall Time	T_R/T_F	LVPECL, LVDS, CML, HCSL ⁴ , Low-Power LVPECL 20/80%	—	—	350	ps
		200 MHz, 20/80%, 2 pF load (LVCMOS)	—	—	750	ps
Minimum Input Pulse Width	T_W		500	—	—	ps
Additive Jitter (Differential Clock Input)	J	$V_{DD} = V_{DDOX} = 2.5/3.3\text{ V}$, LVPECL/LVDS, $F = 725\text{ MHz}$, 0.75 V/ns input slew rate	—	50	65	fs
Propagation Delay	T_{PLH} , T_{PHL}	LVPECL	550	750	950	ns
		LVDS	—	700	—	ns
Output Enable Time	T_{EN}	$F = 1\text{ MHz}$	—	2500	—	ns
		$F = 100\text{ MHz}$	—	30	—	ns
		$F = 725\text{ MHz}$	—	5	—	ns
Output Disable Time	T_{DIS}	$F = 1\text{ MHz}$	—	2000	—	ns
		$F = 100\text{ MHz}$	—	30	—	ns
		$F = 725\text{ MHz}$	—	5	—	ns
Output to Output Skew ⁵	T_{SK}	LVCMOS, drive 12 mA to 2 pF	—	60	—	ps
		LVPECL	—	25	70	ps
		LVDS	—	50	—	ps
Part to Part Skew ⁶	T_{PS}	Differential	—	—	125	ps

Notes:

1. Measured from the initial transition of the corresponding input clock to the falling edge of LOS
2. Measured from the final transition of the corresponding input clock to the rising edge of LOS.
3. When using the on-chip clock divider, a minimum input clock slew rate of 30 mV/ns is required.
4. Measurements were made with receiver termination. See Figure 8 on page 18.
5. Output to Output skew specified for outputs with an identical configuration.
6. Defined as skew between any output on different devices operating at the same supply voltages, temperatures, and equal load conditions. Using the same type of inputs on each device, the outputs are measured at the differential cross points.
7. Measured for 156.25 MHz carrier frequency. Sine-wave noise added to V_{DDOX} ($3.3\text{ V} = 100\text{ mV}_{PP}$) and noise spur amplitude measured. See “AN491: Power Supply Rejection for Low-Jitter Clocks” for further details.

Table 10. AC Characteristics (Continued) $(V_{DD} = V_{DDOX} = 1.8\text{ V} \pm 5\%, 2.5\text{ V} \pm 5\%, \text{ or } 3.3\text{ V} \pm 10\%, T_A = -40\text{ to } 85\text{ }^\circ\text{C})$

Parameter	Symbol	Test Condition	Min	Typ	Max	Unit
Power Supply Noise Rejection ⁷	PSRR	10 kHz sinusoidal noise	—	-63	—	dBc
		100 kHz sinusoidal noise	—	-62	—	dBc
		500 kHz sinusoidal noise	—	-58	—	dBc
		1 MHz sinusoidal noise	—	-55	—	dBc

Notes:

1. Measured from the initial transition of the corresponding input clock to the falling edge of LOS
2. Measured from the final transition of the corresponding input clock to the rising edge of LOS.
3. When using the on-chip clock divider, a minimum input clock slew rate of 30 mV/ns is required.
4. Measurements were made with receiver termination. See Figure 8 on page 18.
5. Output to Output skew specified for outputs with an identical configuration.
6. Defined as skew between any output on different devices operating at the same supply voltages, temperatures, and equal load conditions. Using the same type of inputs on each device, the outputs are measured at the differential cross points.
7. Measured for 156.25 MHz carrier frequency. Sine-wave noise added to V_{DDOX} ($3.3\text{ V} = 100\text{ mV}_{PP}$) and noise spur amplitude measured. See "AN491: Power Supply Rejection for Low-Jitter Clocks" for further details.

Table 11. Additive Jitter, Differential Clock Input

V_{DD}	Input ^{1,2}				Output	Additive Jitter (fs rms, 12 kHz to 20 MHz) ³	
	Freq (MHz)	Clock Format	Amplitude V_{IN} (Single-Ended, Peak-to-Peak)	Differential 20%-80% Slew Rate (V/ns)		Clock Format	Typ
3.3	725	Differential	0.15	0.637	LVPECL	45	65
3.3	725	Differential	0.15	0.637	LVDS	50	65
3.3	156.25	Differential	0.5	0.458	LVPECL	160	185
3.3	156.25	Differential	0.5	0.458	LVDS	150	200
2.5	725	Differential	0.15	0.637	LVPECL	45	65
2.5	725	Differential	0.15	0.637	LVDS	50	65
2.5	156.25	Differential	0.5	0.458	LVPECL	145	185
2.5	156.25	Differential	0.5	0.458	LVDS	145	195

Notes:

1. For best additive jitter results, use the fastest slew rate possible. See "AN766: Understanding and Optimizing Clock Buffer's Additive Jitter Performance" for more information.
2. AC-coupled differential inputs.
3. Measured differentially using a balun at the phase noise analyzer input. See Figure 1.

Table 12. Additive Jitter, Single-Ended Clock Input

V _{DD}	Input ^{1,2}				Output	Additive Jitter (fs rms, 12 kHz to 20 MHz) ³	
	Freq (MHz)	Clock Format	Amplitude V _{IN} (single-ended, peak to peak)	SE 20%-80% Slew Rate (V/ns)		Clock Format	Typ
3.3	200	Single-ended	1.70	1	LVC MOS ⁴	120	160
3.3	156.25	Single-ended	2.18	1	LVPECL	160	185
3.3	156.25	Single-ended	2.18	1	LVDS	150	200
3.3	156.25	Single-ended	2.18	1	LVC MOS ⁴	130	180
2.5	200	Single-ended	1.70	1	LVC MOS ⁵	120	160
2.5	156.25	Single-ended	2.18	1	LVPECL	145	185
2.5	156.25	Single-ended	2.18	1	LVDS	145	195
2.5	156.25	Single-ended	2.18	1	LVC MOS ⁵	140	180

Notes:

1. For best additive jitter results, use the fastest slew rate possible. See “AN766: Understanding and Optimizing Clock Buffer’s Additive Jitter Performance” for more information.
2. DC-coupled single-ended inputs.
3. Measured differentially using a balun at the phase noise analyzer input. See Figure 1. LVC MOS jitter is measured single-ended.
4. Drive Strength: 12 mA, 3.3 V (SFOUT = 11).
5. Drive Strength: 9 mA, 2.5 V (SFOUT = 11).

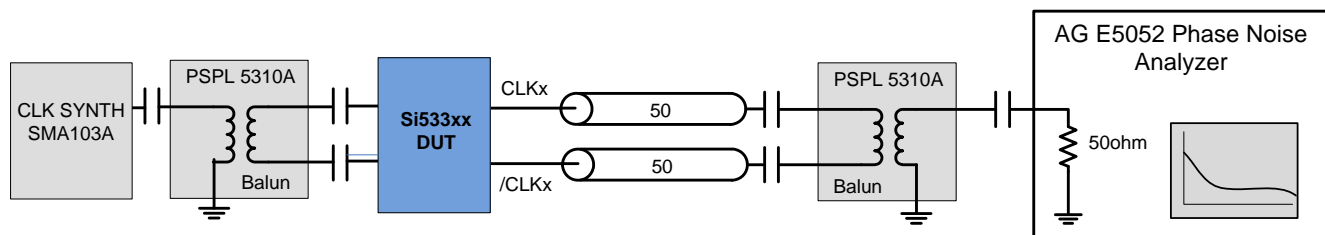

Figure 1. Differential Measurement Method Using a Balun

Table 13. Thermal Conditions

Parameter	Symbol	Test Condition	Value	Unit
Thermal Resistance, Junction to Ambient	θ_{JA}	Still air	46.2	°C/W
Thermal Resistance, Junction to Case	θ_{JC}	Still air	27.1	°C/W

Table 14. Absolute Maximum Ratings

Parameter	Symbol	Test Condition	Min	Typ	Max	Unit
Storage Temperature	T_S		-55	—	150	°C
Supply Voltage	V_{DD}		-0.5	—	3.8	V
Input Voltage	V_{IN}		-0.5	—	$V_{DD} + 0.3$	V
Output Voltage	V_{OUT}		—	—	$V_{DD} + 0.3$	V
ESD Sensitivity	HBM	HBM, 100 pF, 1.5 k Ω	—	—	2000	V
ESD Sensitivity	CDM		—	—	500	V
Peak Soldering Reflow Temperature	T_{PEAK}	Pb-Free; Solder reflow profile per JEDEC J-STD-020	—	—	260	°C
Maximum Junction Temperature	T_J		—	—	125	°C

Note: Stresses beyond those listed in this table may cause permanent damage to the device. Functional operation specification compliance is not implied at these conditions. Exposure to maximum rating conditions for extended periods may affect device reliability.

2. Functional Description

The Si53302 is a low jitter, low skew 1:10 differential buffer with an integrated 2:1 input mux. The device has a universal input that accepts most common differential or LVCMOS input signals. A clock select pin is used to select the active input clock. The selected clock input is routed to two independent banks of outputs. Each output bank features control pins to select signal format, output enable, output divider setting and LVCMOS drive strength.

2.1. Universal, Any-Format Input

The Si53302 has a universal input stage that enables simple interfacing to a wide variety of clock formats, including LVPECL, low-power LVPECL, LVCMOS, LVDS, HCSL, and CML. Tables 15 and 16 summarize the various ac- and dc-coupling options supported by the device. Figures 3 and 4 show the recommended input clock termination options. For the best high-speed performance, the use of differential formats is recommended. For both single-ended and differential input clocks, the fastest possible slew rate is recommended since low slew rates can increase the noise floor and degrade jitter performance. Though not required, a minimum slew rate of 0.75 V/ns is recommended for differential formats and 1.0 V/ns for single-ended formats.

Table 15. LVPECL, LVCMOS, and LVDS

	LVPECL		LVCMOS		LVDS	
	AC-Couple	DC-Couple	AC-Couple	DC-Couple	AC-Couple	DC-Couple
1.8 V	N/A	N/A	No	No	Yes	No
2.5/3.3 V	Yes	Yes	No	Yes	Yes	Yes

Table 16. HCSL and CML

	HCSL		CML	
	AC-Couple	DC-Couple	AC-Couple	DC-Couple
1.8 V	No	No	Yes	No
2.5/3.3 V	Yes (3.3 V)	Yes (3.3 V)	Yes	No

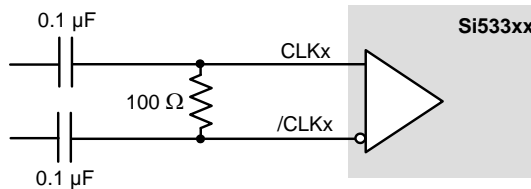

Figure 2. Differential HCSL, LVPECL, Low-Power LVPECL, LVDS, CML AC-Coupled Input Termination

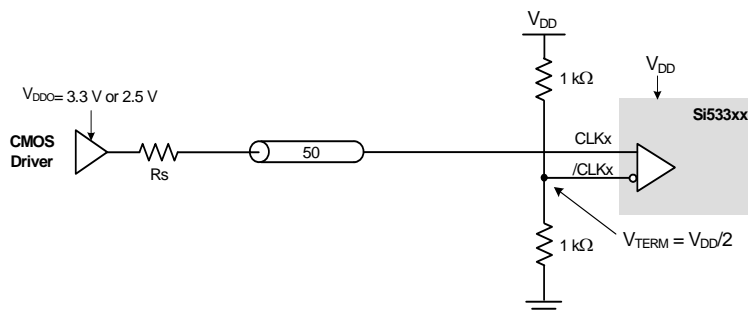
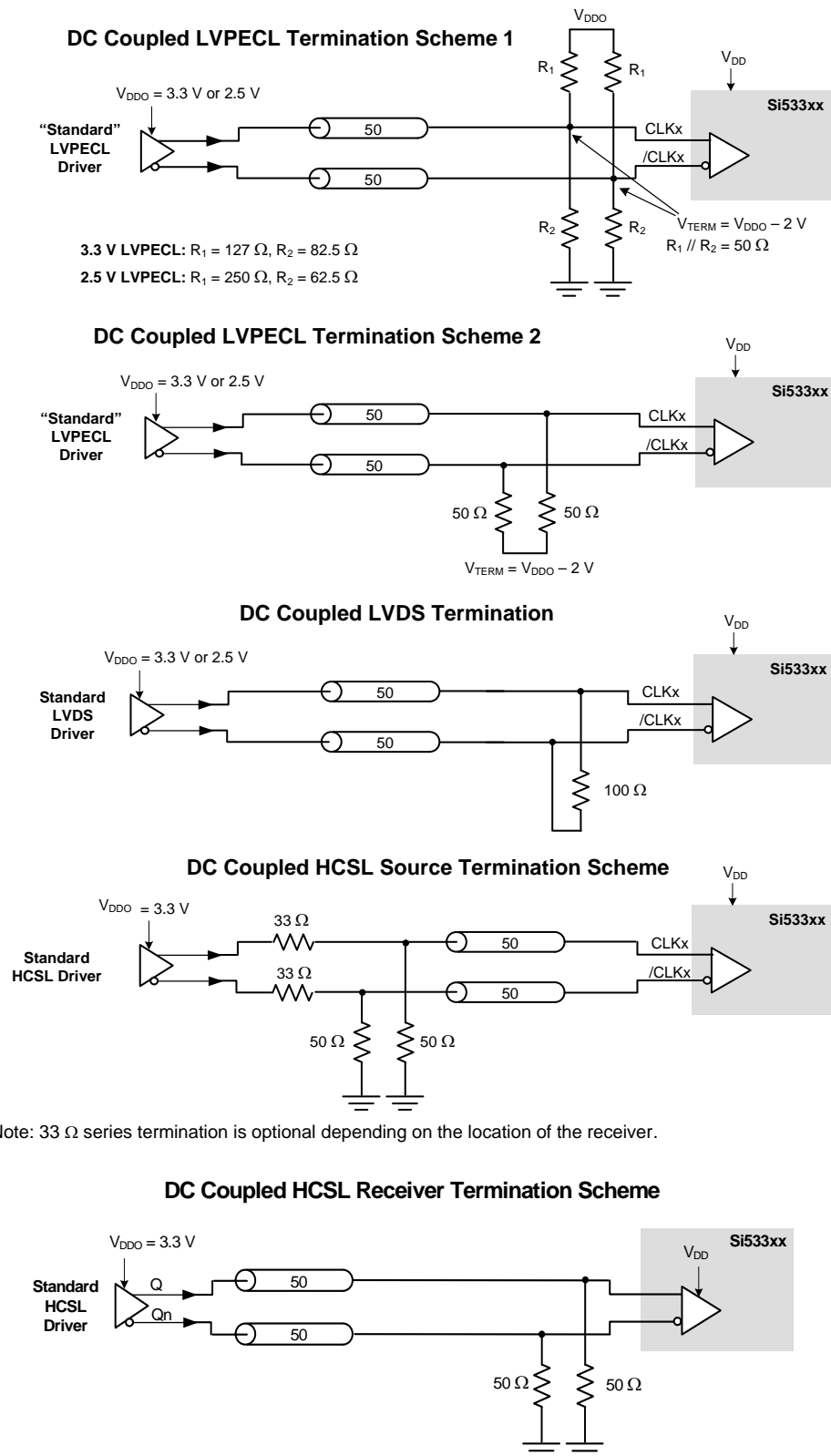

Figure 3. LVCMOS DC-Coupled Input Termination



Note: 33 Ω series termination is optional depending on the location of the receiver.

Figure 4. Differential DC-Coupled Input Terminations

2.2. Input Bias Resistors

Internal bias resistors ensure a differential output low condition in the event that the clock inputs are not connected. The noninverting input is biased with a 18.75 kΩ pulldown to GND and a 75 kΩ pullup to V_{DD}. The inverting input is biased with a 75 kΩ pullup to V_{DD}.

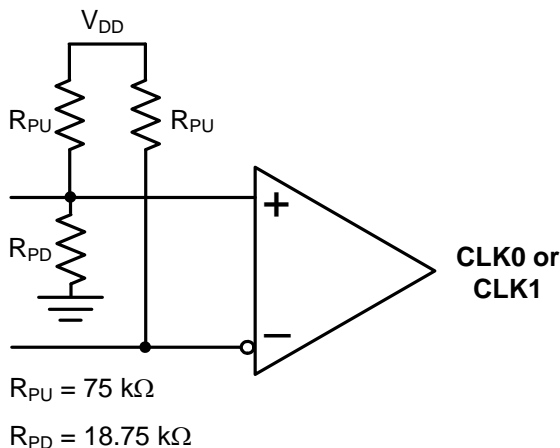

Figure 5. Input Bias Resistors

2.3. Universal, Any-Format Output Buffer

The Si53302 has highly flexible output drivers that support a wide range of clock signal formats, including LVPECL, low power LVPECL, LVDS, CML, HCSL, and LVCMOS. SFOUTX[1] and SFOUTX[0] are 3-level inputs that can be pin-strapped to select the Bank A or Bank B clock signal formats. This feature enables the device to be used for format translation in addition to clock distribution, minimizing the number of unique buffer part numbers required in a typical application and simplifying design reuse. For EMI reduction applications, four LVCMOS drive strength options are available for each V_{DDO} setting.

Table 17. Output Signal Format Selection

SFOUTX[1]	SFOUTX[0]	V _{DDOX} = 3.3 V	V _{DDOX} = 2.5 V	V _{DDOX} = 1.8 V
Open*	Open*	LVPECL	LVPECL	N/A
0	0	LVDS	LVDS	LVDS
0	1	LVCMOS, 24 mA drive	LVCMOS, 18 mA drive	N/A
1	0	LVCMOS, 18 mA drive	LVCMOS, 12 mA drive	N/A
1	1	LVCMOS, 12 mA drive	LVCMOS, 9 mA drive	N/A
Open*	0	LVCMOS, 6 mA drive	LVCMOS, 4 mA drive	N/A
Open*	1	LVPECL low power	LVPECL low power	N/A
0	Open*	CML	CML	CML
1	Open*	HCSL	N/A	N/A

***Note:** SFOUTX are 3-level input pins. Tie low for “0” setting. Tie high for “1” setting. When left open, the pin floats to V_{DD}/2.

2.4. Glitchless Clock Input Switching

The Si53302 features glitchless switching between two valid input clocks. Figure 6 illustrates that switching between input clocks does not generate runt pulses or glitches at the output.

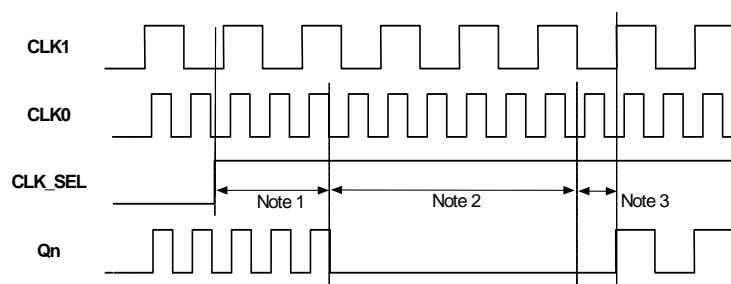

Notes:

1. Q_n continues with CLK0 for 2-3 falling edges of CLK0.
2. Q_n is disabled low for 2-3 falling edges of CLK1.
3. Q_n starts on the first rising edge after 1 + 2.

Figure 6. Glitchless Input Clock Switch

The Si53302 supports glitchless switching between clocks at the same frequency. In addition, the device supports glitchless switching between 2 input clocks that are up to 10x different in frequency. When a switchover to a new clock is made, the output will disable low after two or three clock cycles of the previously-selected input clock. The outputs will remain low for up to three clock cycles of the newly-selected clock, after which the outputs will start from the newly-selected input. In the case a switchover to an absent clock is made, the output will glitchlessly stop low and wait for edges of the newly selected clock. A switchover from an absent clock to a live clock will also be glitchless. Note that the CLK_SEL input should not be toggled faster than 1/250th the frequency of the slower input clock.

2.5. Synchronous Output Enable

The Si53302 features a synchronous output enable (disable) feature. Output enable is sampled and synchronized on the falling edge of the input clock. This feature prevents runt pulses from being generated when the outputs are enabled or disabled.

When OE is low, Q is held low and \bar{Q} is held high for differential output formats. For LVCMOS output format options, both Q and \bar{Q} are held low when OE is set low. The device outputs are enabled when the output enable pin is unconnected. See Table 10, "AC Characteristics," on page 7 for output enable and output disable times.

2.6. Loss of Signal (LOS) Indicator

The LOS0 and LOS1 indicators monitor for the presence of input clocks CLK0 and CLK1, respectively. In the event that an input clock is not present, the associated LOSx pin will assume a logic high (LOSx = 1) state. When a clock is present at the associated input clock pin, the LOSx pin will assume a logic low (LOSx = 0) state.

2.7. Flexible Output Divider

The Si53302 provides optional clock division in addition to clock distribution. The divider setting for each bank of output clocks is selected via 3-level control pins as shown in the table below. Leaving the DIVX pins open will force a divider value of 1 which is the default mode of operation.

Table 18. Divider Selection

DIVX	Divider Value
Open*	÷1 (default)
0	÷2
1	÷4

***Note:** DIVX are 3-level input pins. Tie low for “0” setting. Tie high for “1” setting. When left open, the pin floats to $V_{DD}/2$.

2.8. Input Mux and Output Enable Logic

The Si53302 provides two clock inputs for applications that need to select between one of two clock sources. The CLK_SEL pin selects the active clock input. Table 19 summarizes the input and output clock based on the input mux and output enable pin settings.

Table 19. Input Mux and Output Enable Logic

CLK_SEL	CLK0	CLK1	OE ¹	Q ²
L	L	X	H	L
L	H	X	H	H
H	X	L	H	L
H	X	H	H	H
X	X	X	L	L ³

Notes:

- Output enable active high.
- On the next negative transition of CLK0 or CLK1.
- Single-end: Q = low, \overline{Q} = low.
Differential: Q = low, \overline{Q} = high.

2.9. Power Supply (V_{DD} and V_{DDOX})

The device includes separate core (V_{DD}) and output driver supplies (V_{DDOX}). This feature allows the core to operate at a lower voltage than V_{DDO} , reducing current consumption in mixed supply applications. The core V_{DD} supports 3.3, 2.5, or 1.8 V. Each output bank has its own V_{DDOX} supply, supporting 3.3, 2.5, or 1.8 V.

2.10. Output Clock Termination Options

The recommended output clock termination options are shown below. Unused outputs can be left floating. Do not short unused outputs to ground.

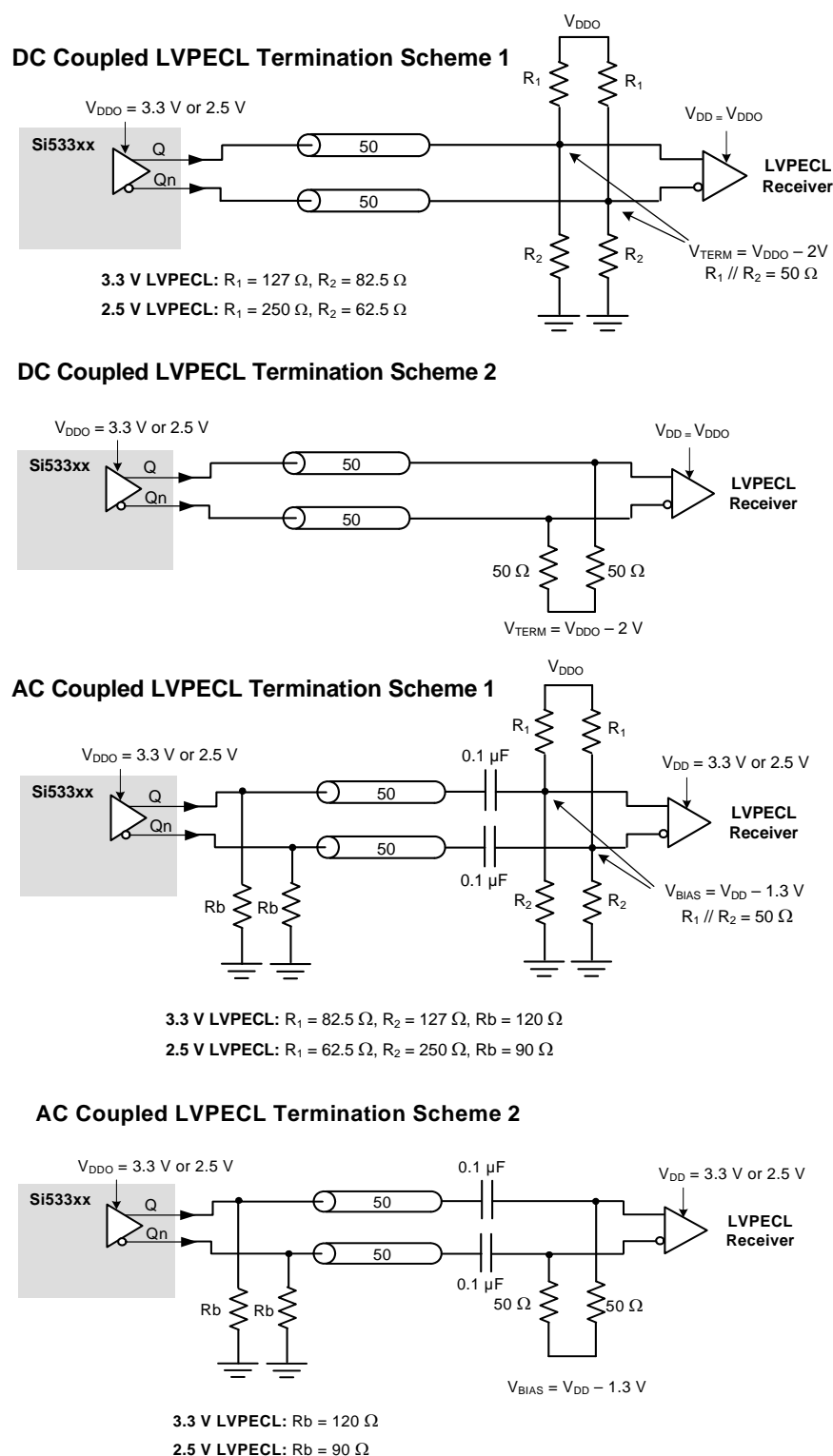

Figure 7. LVPECL Output Termination

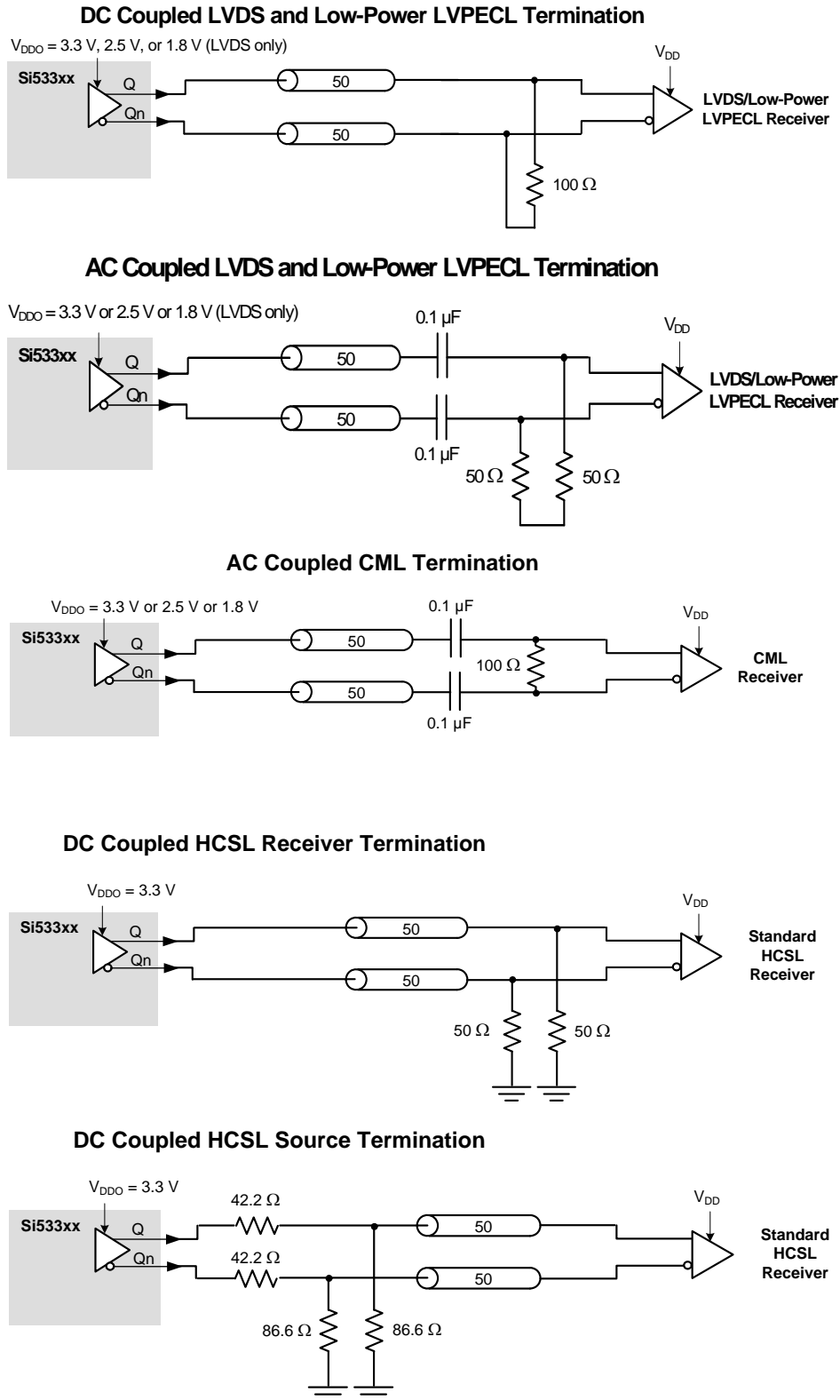

Figure 8. LVDS, CML, HCSL, and Low-Power LVPECL Output Termination

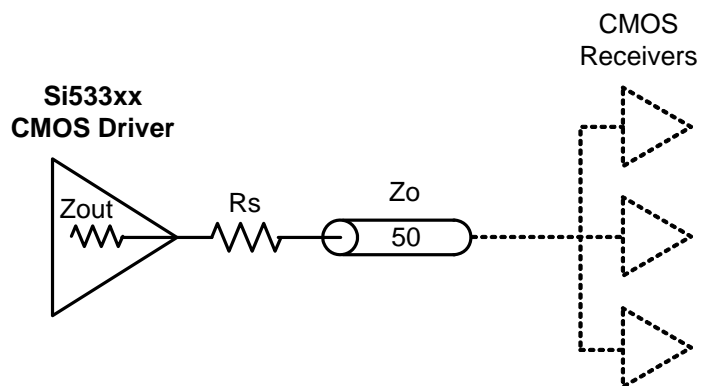

Figure 9. LVC MOS Output Termination

Table 20. Recommended LVC MOS R_S Series Termination

SFOUTX[1]	SFOUTX[0]	R_S (ohms)	
		3.3 V	2.5 V
0	1	33	33
1	0	33	33
1	1	33	33
Open	0	0	0

2.11. AC Timing Waveforms

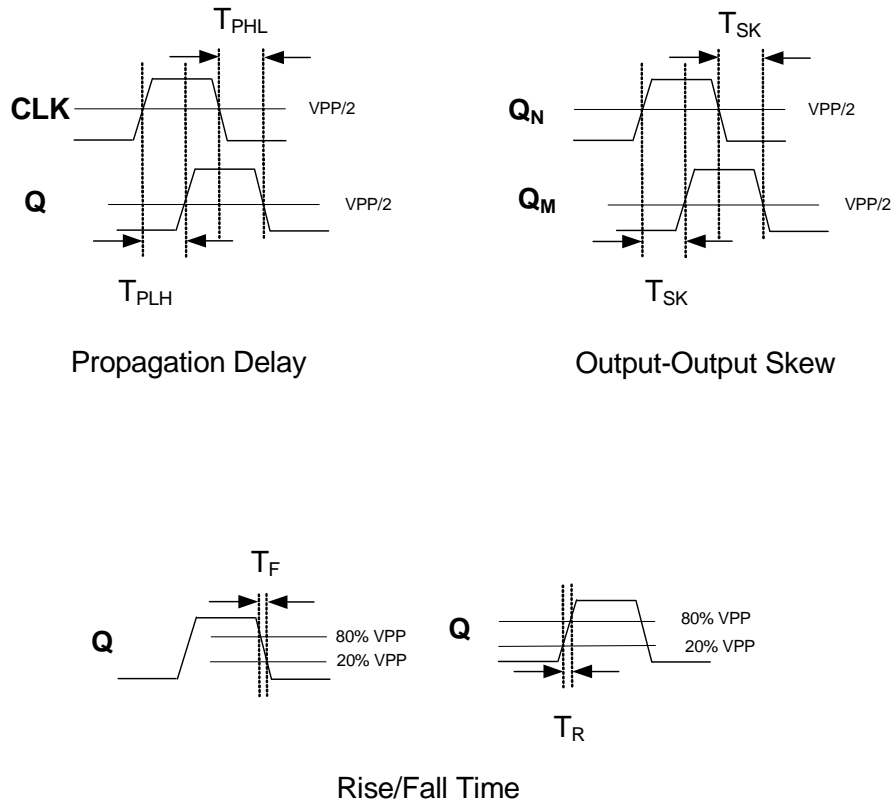

Figure 10. AC Waveforms

2.12. Typical Phase Noise Performance

Each of the following three figures shows three phase noise plots superimposed on the same diagram.

Source Jitter: Reference clock phase noise.

Total Jitter (SE): Combined source and clock buffer phase noise measured as a single-ended output to the phase noise analyzer and integrated from 12 kHz to 20 MHz.

Total Jitter (Diff'I): Combined source and clock buffer phase noise measured as a differential output to the phase noise analyzer and integrated from 12 kHz to 20 MHz. The differential measurement as shown in each figure is made using a balun. See Figure 1 on page 10.

Note: To calculate the total RMS phase jitter when adding a buffer to your clock tree, use the root-sum-square (RSS).

The total jitter is a measure of the source plus the buffer's additive phase jitter. The additive jitter (rms) of the buffer can then be calculated (via root-sum-square addition).

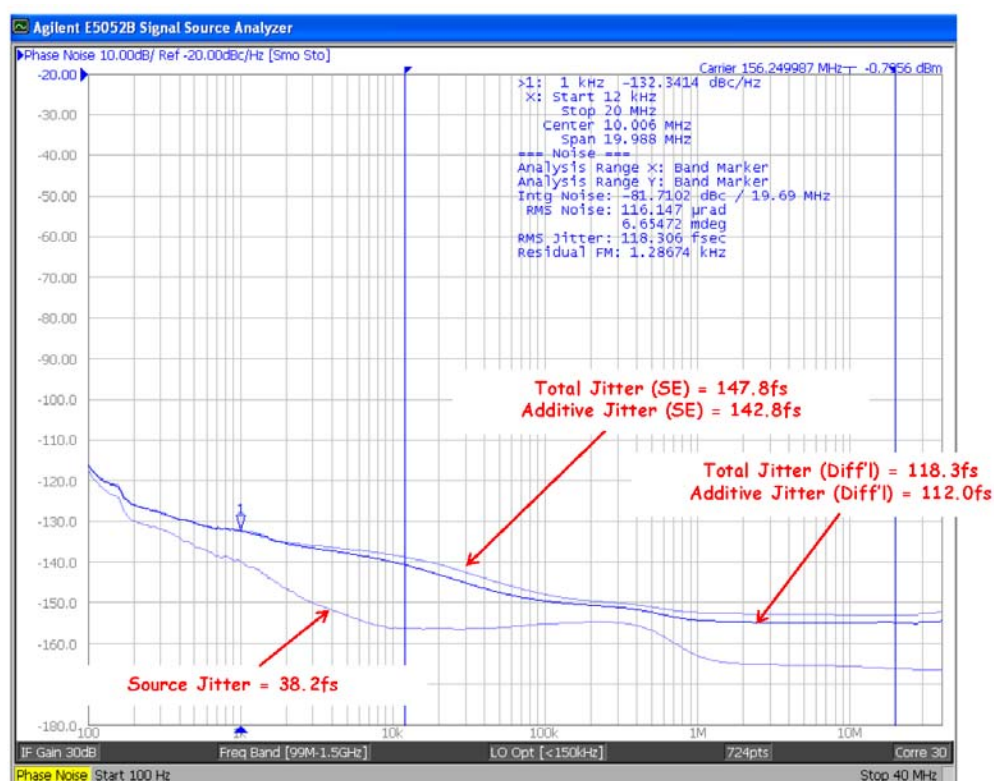

Frequency (MHz)	Diff'I Input Slew Rate (V/ns)	Source Jitter (fs)	Total Jitter (SE) (fs)	Additive Jitter (SE) (fs)	Total Jitter (Diff'I) (fs)	Additive Jitter (Diff'I) (fs)
156.25	1.0	38.2	147.8	142.8	118.3	112.0

Figure 11. Source, Additive, and Total Jitter (156.25 MHz)

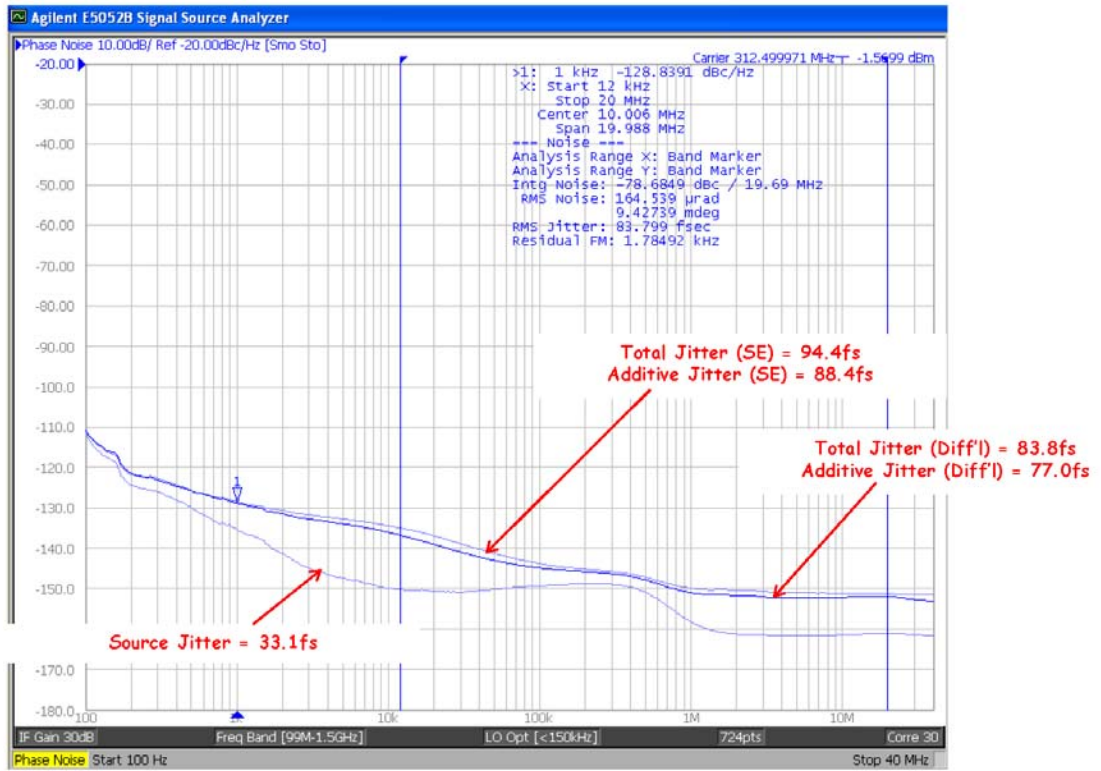

Frequency (MHz)	Diff'l Input Slew Rate (V/ns)	Source Jitter (fs)	Total Jitter (SE) (fs)	Additive Jitter (SE) (fs)	Total Jitter (Diff'l) (fs)	Additive Jitter (Diff'l) (fs)
312.5	1.0	33.10	94.39	88.39	83.80	76.99

Figure 12. Source, Additive, and Total Jitter (312.5 MHz)

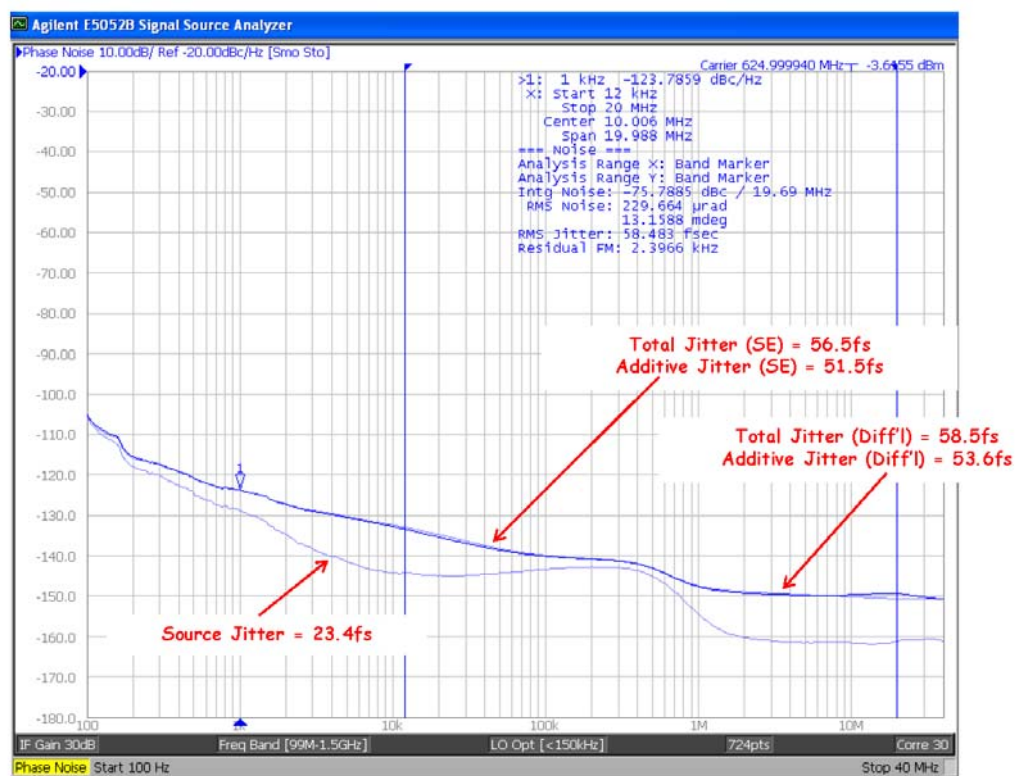

Frequency (MHz)	Diff'l Input Slew Rate (V/ns)	Source Jitter (fs)	Total Jitter (SE) (fs)	Additive Jitter (SE) (fs)	Total Jitter (Diff'l) (fs)	Additive Jitter (Diff'l) (fs)
625	1.0	23.4	56.5	51.5	58.5	53.6

Figure 13. Source, Additive, and Total Jitter (625 MHz)

2.13. Input Mux Noise Isolation

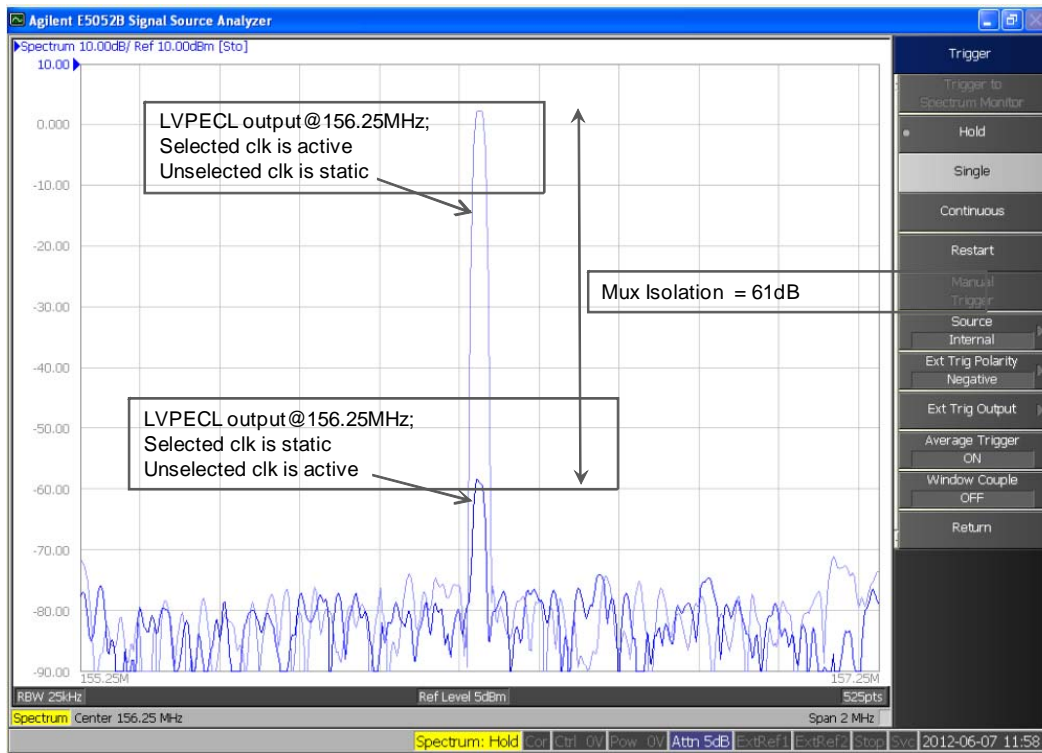

Figure 14. Input Mux Noise Isolation

2.14. Power Supply Noise Rejection

The device supports on-chip supply voltage regulation to reject noise present on the power supply, simplifying low jitter operation in real-world environments. This feature enables robust operation alongside FPGAs, ASICs and SoCs and may reduce board-level filtering requirements. For more information, see AN491: Power Supply Rejection for Low Jitter Clocks.

3. Pin Description: 44-Pin QFN

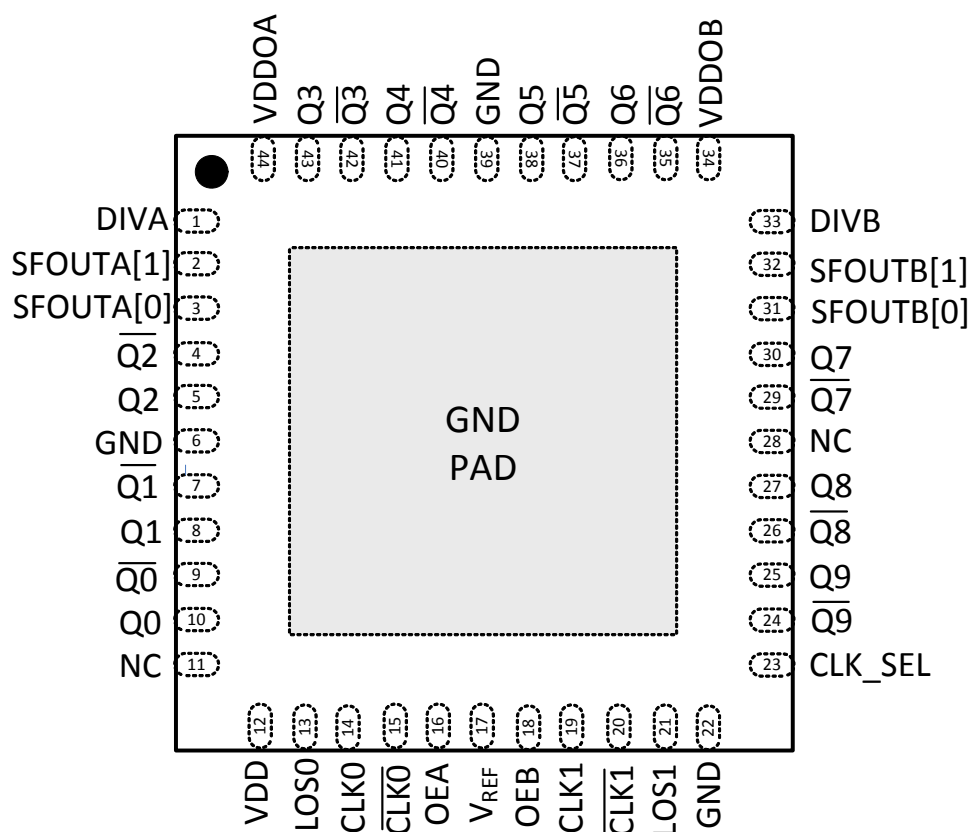

Table 21. Si53302 44-Pin QFN Descriptions

Pin #	Name	Description
1	DIVA	Output divider control pin for Bank A Three-level input control. Internally biased at VDD/2. Can be left floating or tied to ground or V _{DD} .
2	SFOUTA[1]	Output signal format control pin for Bank A Three-level input control. Internally biased at VDD/2. Can be left floating or tied to ground or V _{DD} .
3	SFOUTA[0]	Output signal format control pin for Bank A Three-level input control. Internally biased at VDD/2. Can be left floating or tied to ground or V _{DD} .
4	$\overline{Q2}$	Output clock 2 (complement)
5	Q2	Output clock 2
6	GND	Ground
7	$\overline{Q1}$	Output clock 1 (complement)
8	Q1	Output clock 1

Table 21. Si53302 44-Pin QFN Descriptions (Continued)

Pin #	Name	Description
9	$\overline{Q0}$	Output clock 0 (complement)
10	Q0	Output clock 0
11	NC	No connect
12	VDD	Core voltage supply Bypass with 1.0 μ F capacitor and place close to the VDD pin as possible
13	LOS0	The LOS0 status pin indicates whether a clock is present (LOS0 = 0) or not present (LOS0 = 1) at the CLK0 pin.
14	CLK0	Input clock 0
15	$\overline{CLK0}$	Input clock 0 (complement) When CLK0 is driven by a single-ended input, connect $\overline{CLK0}$ to VDD/2.
16	OEA	Output enable—Bank A When OE = high, the Bank A outputs are enabled When OE = low, Q is held low and \overline{Q} is held high for differential formats For LVCMOS, both Q and \overline{Q} are held low when OE is set low OEA contains an internal pull-up resistor
17	V _{REF}	Input reference voltage.
18	OEB	Output enable—Bank B When OE = high, the Bank B outputs are enabled When OE = low, Q is held low and \overline{Q} is held high for differential formats For LVCMOS, both Q and \overline{Q} are held low when OE is set low OEB contains an internal pull-up resistor.
19	CLK1	Input clock 1
20	$\overline{CLK1}$	Input clock 1 (complement) When CLK1 is driven by a single-ended input, connect $\overline{CLK1}$ to VDD/2.
21	LOS1	The LOS1 status pin indicates whether a clock is present (LOS1 = 0) or not present (LOS1 = 1) at the CLK1 pin.
22	GND	Ground
23	CLK_SEL	MUX input select pin (LVCMOS) Clock inputs are switched without the introduction of glitches When CLK_SEL is high, CLK1 is selected When CLK_SEL is low, CLK0 is selected CLK_SEL contains an internal pull-down resistor
24	$\overline{Q9}$	Output clock 9 (complement)
25	Q9	Output clock 9
26	$\overline{Q8}$	Output clock 8 (complement)
27	Q8	Output clock 8

Table 21. Si53302 44-Pin QFN Descriptions (Continued)

Pin #	Name	Description
28	NC	No connect
29	$\overline{Q7}$	Output clock 7 (complement)
30	Q7	Output clock 7
31	SFOUTB[0]	Output signal format control pin for Bank B Three-level input control. Internally biased at VDD/2. Can be left floating or tied to ground or V _{DD} .
32	SFOUTB[1]	Output signal format control pin for Bank B Three-level input control. Internally biased at VDD/2. Can be left floating or tied to ground or V _{DD} .
33	DIVB	Output divider configuration bit for Bank B Three-level input control. Internally biased at VDD/2. Can be left floating or tied to ground or V _{DD} .
34	V _{DDOB}	Output Clock Voltage Supply—Bank B (Outputs: Q5 to Q9) Bypass with 1.0 μ F capacitor and place close to the V _{DDOB} pin as possible
35	$\overline{Q6}$	Output clock 6 (complement)
36	Q6	Output clock 6
37	$\overline{Q5}$	Output clock 5 (complement)
38	Q5	Output clock 5
39	GND	Ground
40	$\overline{Q4}$	Output clock 4 (complement)
41	Q4	Output clock 4
42	$\overline{Q3}$	Output clock 3 (complement)
43	Q3	Output clock 3
44	V _{DDOA}	Output Voltage Supply—Bank A (Outputs: Q0 to Q4) Bypass with 1.0 μ F capacitor and place close to the V _{DDOA} pin as possible
GND Pad	GND	Ground Pad Power supply ground and thermal relief

Si53302

4. Ordering Guide

Part Number ^{1,2}	Package	PB-Free, ROHS-6	Temperature
Si53302-B-GM	44-QFN	Yes	-40 to 85 °C
Si53301/4-EVB	NA	Yes	-40 to 85 °C

Notes:

1. To buy, go to <http://www.supplier-direct.com/silabs/Cart.aspx?supplierUVID=63410000&partnumber=Si53302-B-GM&quantity=1&issample=0>.
2. To sample, go to <http://www.supplier-direct.com/silabs/Cart.aspx?supplierUVID=63410000&partnumber=Si53302-B-GM&quantity=1&issample=1>.

5. Package Outline

5.1. 7x7 mm 44-QFN Package Diagram

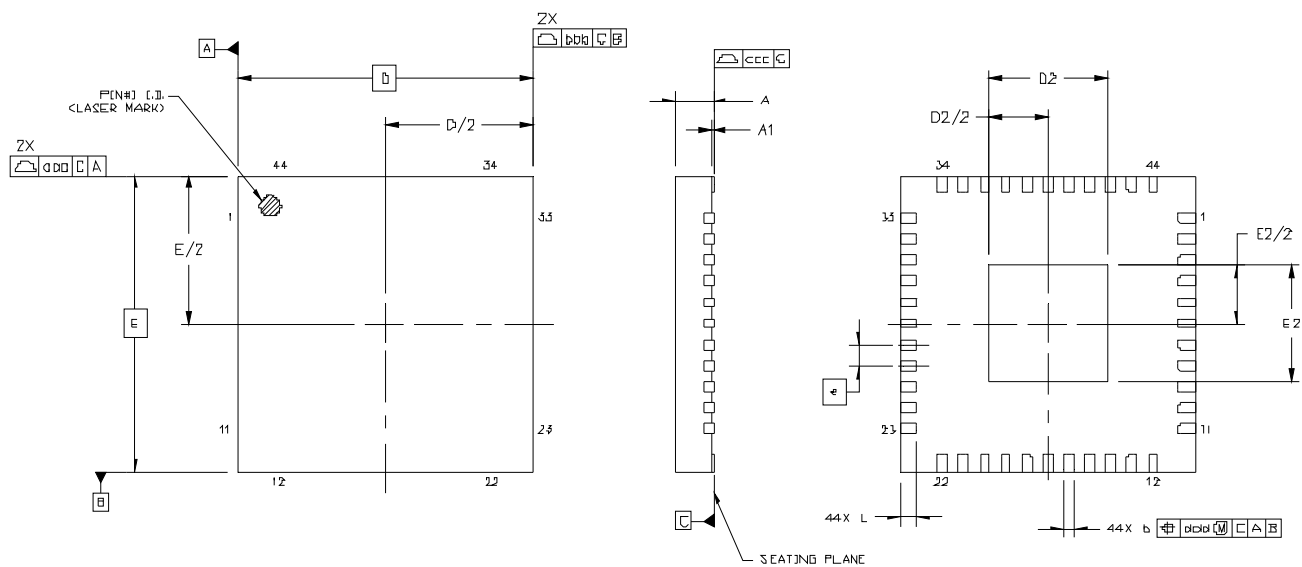

Figure 15. Si53302 7x7 mm 44-QFN Package Diagram

Table 22. Package Diagram Dimensions

Dimension	MIN	NOM	MAX
A	0.80	0.85	0.90
A1	0.00	0.02	0.05
b	0.18	0.25	0.30
D	7.00 BSC		
D2	2.65	2.80	2.95
e	0.50 BSC		
E	7.00 BSC		
E2	2.65	2.80	2.95
L	0.30	0.40	0.50
aaa	—	—	0.10
bbb	—	—	0.10
ccc	—	—	0.08
ddd	—	—	0.10
Notes:			
<ol style="list-style-type: none"> 1. All dimensions shown are in millimeters (mm) unless otherwise noted. 2. Dimensioning and Tolerancing per ANSI Y14.5M-1994. 3. This drawing conforms to the JEDEC Solid State Outline MO-220. 4. Recommended card reflow profile is per the JEDEC/IPC J-STD-020 specification for Small Body Components. 			

6. PCB Land Pattern

6.1. 7x7 mm 44-QFN Package Land Pattern

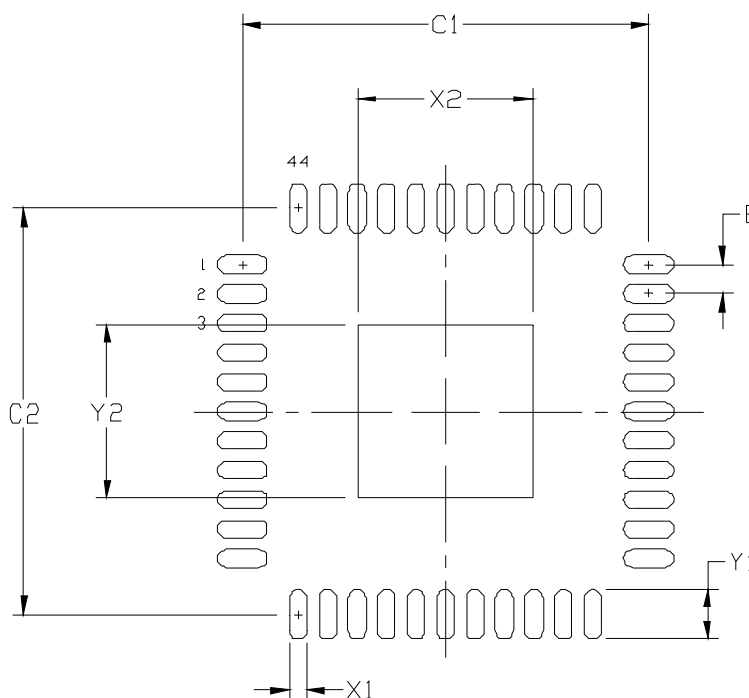

Figure 16. Si53302 7x7 mm 44-QFN Package Land Pattern

Table 23. PCB Land Pattern

Dimension	Min	Max	Dimension	Min	Max
C1	6.80	6.90	X2	2.85	2.95
C2	6.80	6.90	Y1	0.75	0.85
E	0.50 BSC		Y2	2.85	2.95
X1	0.20	0.30			

Notes:

General

1. All dimensions shown are in millimeters (mm) unless otherwise noted.
2. This Land Pattern Design is based on the IPC-7351 guidelines.

Solder Mask Design

1. All metal pads are to be non-solder mask defined (NSMD). Clearance between the solder mask and the metal pad is to be 60 μm minimum, all the way around the pad.

Stencil Design

1. A stainless steel, laser-cut and electro-polished stencil with trapezoidal walls should be used to assure good solder paste release.
2. The stencil thickness should be 0.125 mm (5 mils).
3. The ratio of stencil aperture to land pad size should be 1:1 for all perimeter pads.
4. A 2x2 array of 1.0 mm square openings on 1.45 mm pitch should be used for the center ground pad.

Card Assembly

1. A No-Clean, Type-3 solder paste is recommended.
2. The recommended card reflow profile is per the JEDEC/IPC J-STD-020 specification for Small Body Components.

Si53302

7. Top Marking

7.1. Si53302 Top Marking



7.2. Top Marking Explanation

Mark Method:	Laser	
Font Size:	1.9 Point (26 mils) Right-Justified	
Line 1 Marking:	Device Part Number	53302-B-GM
Line 2 Marking:	YY = Year WW = Work Week	Assigned by Assembly Supplier. Corresponds to the year and work week of the mold date.
	TTTTTT = Mfg Code	Manufacturing Code from the Assembly Purchase Order form.
Line 3 Marking:	Circle = 1.3 mm Diameter Center-Justified	"e3" Pb-Free Symbol
	Country of Origin ISO Code Abbreviation	TW
Line 4 Marking	Circle = 0.75 mm Diameter Filled	Pin 1 Identification

DOCUMENT CHANGE LIST

Revision 0.3 to 0.4

- Formatting changes.
- Updated part number to revision B.
- Added phase noise plot, PSRR figure, input mux isolation figure.
- Updated ac/dc specifications.

Revision 0.4 to 0.41

- Formatting changes.
- Updated ac/dc specifications.

Revision 0.41 to 1.0

- Added Loss of Signal (LOS) feature with description and pin assignments.
- Update operating conditions, including LVCMOS and HCSL voltage support.
- Updated Table 2, “Input Clock Specifications,” on page 4.
- Updated Table 3, “DC Common Characteristics,” on page 5.
- Updated Table 4, “Output Characteristics (LVPECL),” on page 6.
- Updated Table 10, “AC Characteristics,” on page 7.
- Updated output voltage specifications
- Improved data for additive jitter specifications.
- Improved typical phase noise plots.
- Updated input/output termination recommendations.

CONTACT INFORMATION

Silicon Laboratories Inc.

400 West Cesar Chavez
Austin, TX 78701
Tel: 1+(512) 416-8500
Fax: 1+(512) 416-9669
Toll Free: 1+(877) 444-3032

Please visit the Silicon Labs Technical Support web page:
<https://www.silabs.com/support/pages/contacttechnicalsupport.aspx>
and register to submit a technical support request.

Patent Notice

Silicon Labs invests in research and development to help our customers differentiate in the market with innovative low-power, small size, analog-intensive mixed-signal solutions. Silicon Labs' extensive patent portfolio is a testament to our unique approach and world-class engineering team.

The information in this document is believed to be accurate in all respects at the time of publication but is subject to change without notice. Silicon Laboratories assumes no responsibility for errors and omissions, and disclaims responsibility for any consequences resulting from the use of information included herein. Additionally, Silicon Laboratories assumes no responsibility for the functioning of undescribed features or parameters. Silicon Laboratories reserves the right to make changes without further notice. Silicon Laboratories makes no warranty, representation or guarantee regarding the suitability of its products for any particular purpose, nor does Silicon Laboratories assume any liability arising out of the application or use of any product or circuit, and specifically disclaims any and all liability, including without limitation consequential or incidental damages. Silicon Laboratories products are not designed, intended, or authorized for use in applications intended to support or sustain life, or for any other application in which the failure of the Silicon Laboratories product could create a situation where personal injury or death may occur. Should Buyer purchase or use Silicon Laboratories products for any such unintended or unauthorized application, Buyer shall indemnify and hold Silicon Laboratories harmless against all claims and damages.

Silicon Laboratories and Silicon Labs are trademarks of Silicon Laboratories Inc.
Other products or brandnames mentioned herein are trademarks or registered trademarks of their respective holders.

Mouser Electronics

Authorized Distributor

Click to View Pricing, Inventory, Delivery & Lifecycle Information:

[Silicon Laboratories:](#)

[Si53302-B-GM](#) [Si53302-B-GMR](#)