



Active Cooling Solutions



ebmpapst

The engineer's choice

About ebm-papst North America



Headquarters - Farmington, CT

- » 250,000 square feet
- » 20 Regional offices
- » Acoustic testing chamber
- » Complete air testing lab on site
- » ISO 9001 and ISO 14001 Certifications
- » Distribution centers in Farmington (CT) and Toronto, Canada

With offices in major cities throughout North America, our highly-skilled and experienced team of professionals are ready to tackle your air moving challenges with solutions that meet your requirements. ebm-papst serves all markets including IT & Telecommunications, Ventilation, Air-Conditioning, Refrigeration, Gas & Heating, Household Appliances, LED/Lighting, Industrial, Drive Systems, Transportation, Agriculture, Medical, and more. Our customers can always count on prompt, courteous service. Customer satisfaction is our number one priority.



Expert support when and where you need it

Knowledgeable field sales professionals are close by for face-to-face meetings. Dedicated inside sales associates fulfill all your ordering requirements. To assist you with order management, our customer service department provides automated services such as shipment notifications, reorder notifications, and invoicing.

Expert design and manufacturing

Beginning with the initial product concept, our application engineers work in tandem with customers to select the best air moving solution to suit specific goals and requirements. Once the prototype has been established, it can then be tested in our state-of-the-art airflow testing chambers, allowing for the optimization of all air moving solutions. Each chamber has been designed to meet AMCA 210 and ISO 5801 requirements. In addition to our airflow testing capabilities, ebm-papst can conduct comparative sound, temperature, and velocity tests. The electrical engineering team can design simple fan controllers for monitoring fan speed, or complex controllers and power supplies, filtering, and specific communication protocols.

Logistics and inventory management programs

We have over 90,000 square feet of climate-controlled warehousing at our facilities offering real-time inventory transactions and bar-coded inventory. Inventory management programs such as Kanban, demand/pull, safety stock, consignment, and local warehousing can be customized to your needs.



About ebm-papst Worldwide

Passionate about air technology and drive engineering

The ebm-papst product portfolio now numbers over 14,500 products.

Thus we offer the right solution for almost every air technology and drive engineering task. In addition, we work with you to develop very customized solutions that extend beyond our current product line. This is made possible by our extensive team of over 500 dedicated engineers and technicians out of our three central locations in Germany.

World Headquarters: Mulfingen, Germany

- » Elektrobau Mulfingen GmbH & Co. KG (ebm) established in 1963
- » Manufacturing Plants: Germany, Hungary, USA, Slovenia, India, China, Czech Republic and Italy
- » Worldwide Revenue / Sales: Over 1 Billion
- » 47 Sales and Distribution Groups Worldwide
- » 10,000+ Employees Worldwide
- » Ship Over 46 Million Products Annually
- » Certifications: ISO 9001, ISO 14001 & TS 16949 and RoHS Compliant
- » Over 1,000 Patents Held in Fan/ Motor Design

Core competencies: motor technology, aerodynamics and electronics

Our innovative technologies keep turning into new industrial standards. Our advantage: We consider aerodynamic relationships as a whole. Thus we combine benchmark-setting motor technology with the intelligence of state-of-the-art electronics and aerodynamically optimized shapes. The

system solution that result from these three core competencies have a synergy that is unique in all the world and make up the majority of our product line.

GreenTech EC technology: Our motor for the future

Virtually our entire product range is now available with GreenTech, the leading edge EC technology. The wear-free and maintenance-free performance, the longer service life, the noise reduction, the intelligent electronic control, the higher efficiency, along with unparalleled energy efficiency when compared to conventional AC Technology makes GreenTech EC motors from ebm-papst the future of air moving technology.

Passion, quality and responsibility: Three reasons for our success

Only real passion for fans and motors makes the highest level of achievement possible. With a clear organizational structure, flat hierarchies and a high degree of personal responsibility, we create the perfect foundation - not only technological innovation, but also for excellent service and active dedication to closely working with our customers.

Of course, our products are also produced with the highest quality - at a total of 17 product sites worldwide. Our quality management is uncompromising, everywhere and in every process stage. This is also confirmed by our certification of compliance with the international standards DIN EN ISO 9001, ISO/TS 16949-2 and the standard DIN EN ISO 14001.

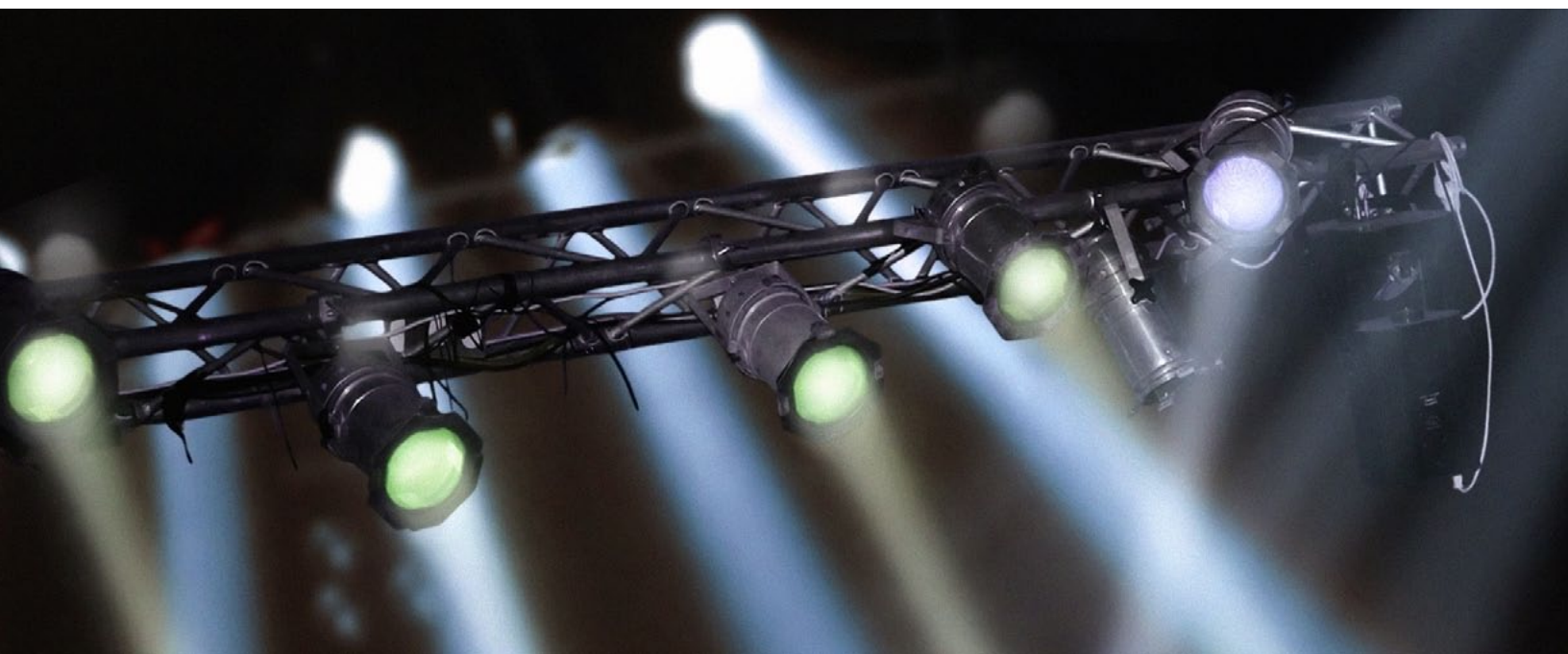
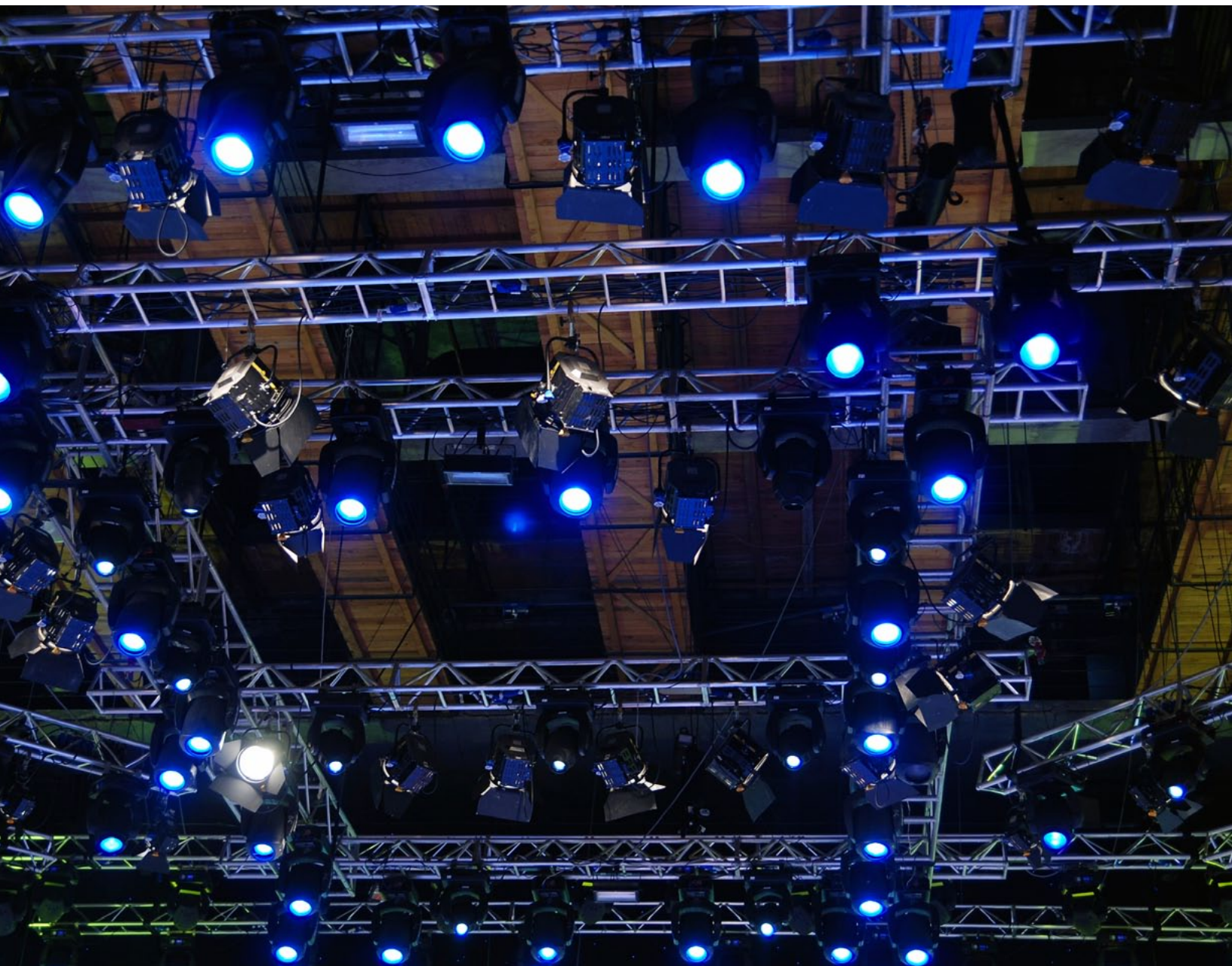

Table of Contents

Active Cooling Solutions

GreenTech	4
Market Overview	5
Active Cooling for Xicato Modules	6
Technical Data for PG1W-12-M3BN	7
Technical Data for PG1W-12-L3BN	8



GreenTech

The symbol of our commitment

GreenTech is a name put to the philosophy ebm-papst has used for decades: "each new product that we develop has to be better than its predecessor in terms of economy and ecology." Our company philosophy is not just for designing new and more efficient fans and blowers; it is in practice in the offices and factories, locally and internationally. At the U.S. headquarters, two separate arrays of solar panels have been installed to provide the engineering building with electricity, along with additional renovations that make the facilities even more environmentally friendly.

GreenTech symbolizes our continuous commitment, achievements, and passion to provide customers with high quality products through the use of modern development and production methods, responsible business practices and initiatives that benefit not only the user, but the environment as well.

What is EC Technology?

EC technology is an important factor in our GreenTech philosophy. ebm-papst EC fans use permanent magnet external rotor DC motors with fully integrated electronic commutation (EC) and AC to DC power conversion. EC motors give the flexibility of connecting to AC mains with the efficiency and simple speed control of a DC motor. With EC fans, the user benefits from the innovative commutation without wear-and-tear on the motor. The EC motor compares to the direct current shunt-wound motor except that the magnetic field is generated by permanent magnets inside the rotor.

With this technology, EC motors and fans can be easily controlled, are maintenance-free, offer outstanding efficiency and have a considerably long service life. The variable speed range possible in EC technology makes using a multitude of individual models a thing of the past.

Our R&D efforts are not only focused on saving energy. In terms of air performance and low noise, our products exceed the toughest specifications. EC technology pays off for every owner or operator, while conserving precious energy resources. When you use intelligent ebm-papst EC technology in your applications, everyone wins - companies, customers, and the environment.



Market Overview

The LED market

With high visible light, low radiant energy, and no infrared or ultraviolet light, LEDs are the most efficient light source in the lighting market today. While as much as 80% more energy efficient than traditional incandescent lighting, LED components still create a considerable amount of heat. High temperatures can cut the lifespan of an LED light in half. Temperatures over the maximum rated junction can quickly weaken the lumen output and the color quality of LEDs.

By dissipating the heat emitted by the LED light source, the efficiency and length of life of the light source can increase exponentially. Thermal management is a key factor in lumen output. For high-lumen output applications, passive cooling is not enough. In order to reach the desired lumen values in a small form factor, active cooling is the perfect solution to effectively disperse the heat produced by LED components.

Active cooling solutions are a new contender in LED thermal management systems. Dissipating heat directly from the core of the modules allows for less thermal resistance, making the entire assembly more efficient. Active cooling technology offers thermal capabilities that are superior to passive heat sinks and can raise performance while significantly reducing the size



of the lighting fixture. With industry-leading German-engineered compact fans and American-designed assemblies, ebm-papst can provide the perfect cooling solution for your LED application. One of the most significant advantages that ebm-papst fans have on the life of the LED light is due to the reliability of our products. With active cooling solutions far surpassing the 50,000+ hour promise the industry is accustomed to, an ebm-papst fan is now the LED light's most efficient cooling source.

Service Life	Series	Dimensions	Max. T environment	Lifetime
Type		mm	°C	hrs
Axial	400, 400F	□ 40 x 10 / 20	-20 + 85°C ¹	120,000 / 90,000
	500F	□ 50 x 15	-20 + 85°C ¹	120,000
	600F, 620	□ 60 x 15 / 25	-20 + 85°C ¹	120,000 / 305,000
	8200J, 8400N, 8450	□ 80 x 38 / 25	-20 + 70°C ²	237,500 / 305,000 / 305,000
	3200J, 3400N	□ 92 x 38 / 25	-20 + 70°C ²	265,000 / 305,000
Radial	4100N, 4300, 4400F	□ 119 x 38 / 32 / 25	-20 + 75°C ³	305,000 / 322,500 / 285,000
	RLF35	□ 51 x 15	-20 + 70°C ³	227,500
	RL48	□ 76 x 27	-20 + 70°C ²	265,000
	RL65	□ 97 x 93.5 x 33	-20 + 70°C ²	227,500

Note: ¹-4 to 185°F; ²-4 to 158°F; ³-4°F to 167°F. Life Expectancy L10 per IPC 9591 at 20°C ambient. Values are dependent on speed and application.

Active Cooling for Xicato Modules

Active cooling for Xicato modules

Thermal management is a key factor that limits the lumen output and efficiency of an LED lightsource. While as much as 80 percent more energy efficient than traditional incandescent lighting, the LED components still create a considerable amount of heat. If this heat is not dissipated properly, the quality of light and life expectancy of the LED lightsource decreases dramatically. In order to reach the desired lumen values in a small form factor, active cooling may be required to effectively dissipate the heat produced by the LED components. Active cooling technology offers thermal capabilities that are superior to passive heat sinks and can raise performance while reducing the size of the lighting fixture.

Benefits of using ebm-papst active cooling solutions

- German-engineered compact fan
- American-designed assembly
- Approved reference design through Xicato
- Life expectancy: in excess of 87,500 hours at ambient temperatures up to 40°C
- Industry leading high reliability: 5 year warranty on the 612FL-698 fan Xicato modules (PG1W-12-60-M3BN and PG1W-12-60-L3BN)
- 100% end of line testing
- Low noise: Custom acoustic isolation ring
 - Fan runs at 7 dB(A)
 - A quiet office has a background noise of about 40 dB(A)
- High efficiency motor design
- Electrical input requires less than 0.18 Watts
- Thermal protection: Thermal isolation ring
- Mounting feature for PG1W-12-60-M3BN is the same Xicato reference design heatsinks (XSA-38)

XICATO



PG1W-12-60-M3BN



PG1W-12-60-L3BN

Nominal data	Nominal voltage	Voltage range	Acoustic noise	Fan-sink thermal resistance (at 50°C)	Thermal power dissipation capability	Thermal ambient class (at 40°C)	Fan speed	Heat sink mass	Power input	Lifetime (at 20°C)	Lifetime (at 40°C)
Type	VDC	VDC	dB(A)	°C/W	W		rpm	g	W	hrs	hrs
PG1W-12-60-M3BN	12	11.5... 13.2	7	1.32	38	Q	1700	212	0.18	197,500	87,500
PG1W-12-60-L3BN	12	11.5... 13.2	7	0.94	53	U	1700	276	0.18	197,500	87,500

Note: Voltages are based on the 612F base fan model. Other voltages available upon request. Life Expectancy L₁₀ per IPC 9591.

Technical Data

PG1W-12-60-M3BN

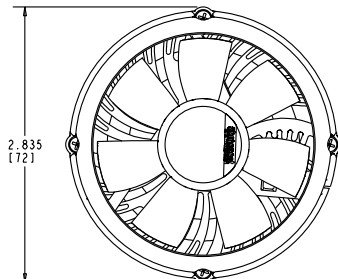
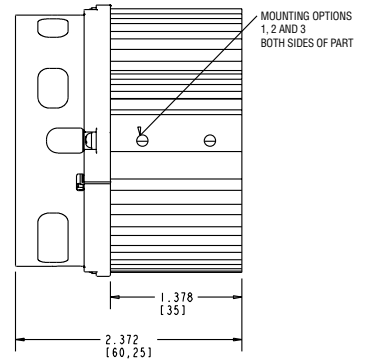
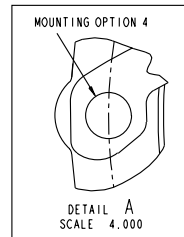
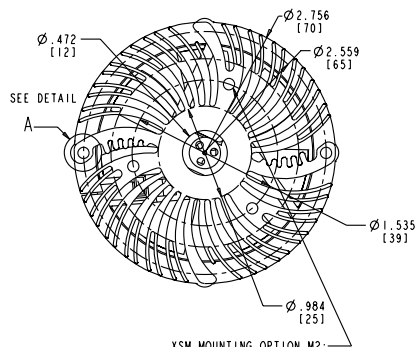
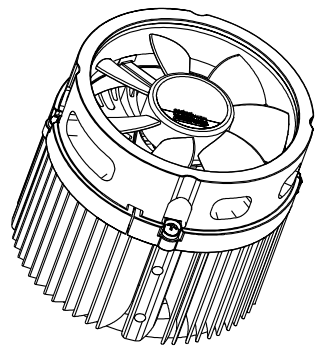
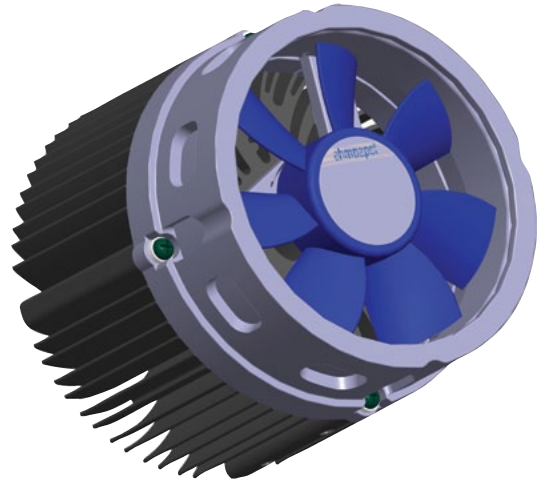
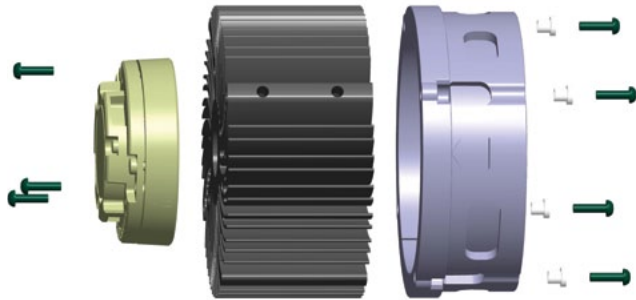

ebm-papst Inc. Part Number
PG1W-12-60- X X X X

HEAT SINK ASSEMBLY
 "M" - XSA-18 style
 "L" - XLA-18 style
 MOUNTING FOR LED
 "3" - M3 Mounting Hole

MOUNTING OPTION
 See Table
 FINISH
 "B" - Black Anodize
 "C" - Clear Anodize

MOUNTING OPTIONS TABLE		
MOUNTING OPTION	THREAD	THREAD DEPTH
None	None	None
1	M2 X 0.4	5mm MIN.
2	M3 X 0.5	5mm MIN.
3	# 6-32 UNC	0.2" MIN.
4	M3 X 0.5	5mm MIN.
5	Option 1 & 4	
6	Option 2 & 4	
7	Option 3 & 4	
N	No additional mounting options	

Technical Data

PG1W-12-60-L3BN

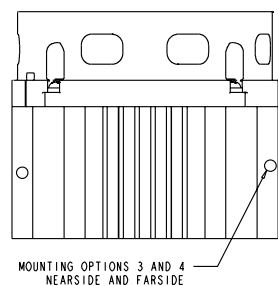
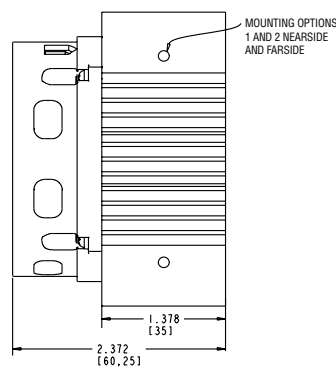
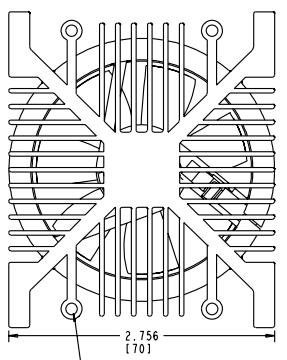
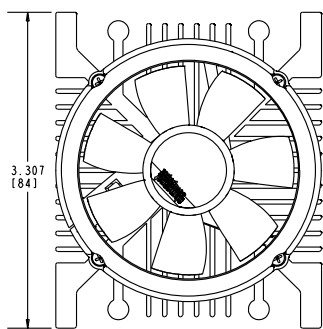
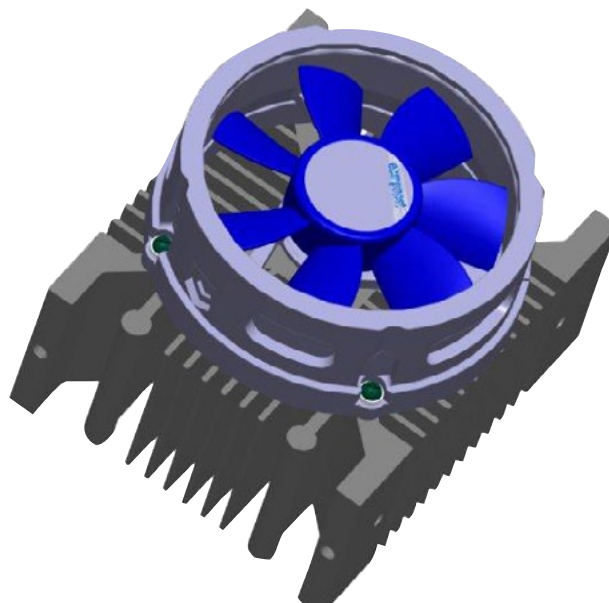
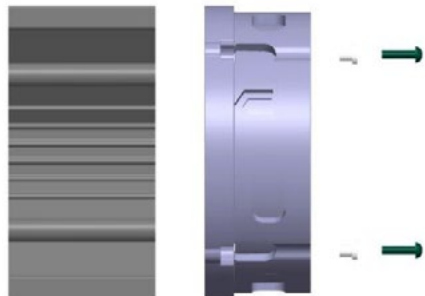

(MODULE SIDE OF ASSEMBLY)
 4X DRILL & TAP M3 X 0.5
 6.5mm MIN THREAD DEPTH
 STANDARD ON ALL ASSEMBLIES.

MOUNTING OPTIONS TABLE		
MOUNTING OPTION	THREAD	THREAD DEPTH
None	None	None
1	M3 X 0.5	6.5mm MIN.
2	# 6-32 UNC	0.25" MIN.
3	M3 X 0.5	6.5mm MIN.
4	#6-32 UNC	0.25" MIN.
N	No additional mounting options	

ebm-papst Inc. Part Number
PG1W-12-60- X X X X

HEAT SINK ASSEMBLY
 "M" - XSA-48 style
 "L" - XLA-18 style

MOUNTING FOR LED
 "3" - M3 Mounting Hole

MOUNTING OPTION
 See Table

FINISH
 "B" - Black Anodize
 "C" - Clear Anodize



Notes

**ebm-papst Inc.
Farmington**

100 Hyde Road
Farmington, CT 06034
Phone + 1 860-674-1515
Fax +1 860-674-8536
sales@us.ebmpapst.com

© ebm-papst Inc. 2013. ebm-papst Inc. reserves the right to change any specifications or data without notice

ebmpapst

The engineer's choice