

Datasheet

RS PID Temperature Controller, 48 x 96mm, 100 → 240 V ac Supply Voltage, 3 Output Relay

RS Stock number 774-0294



Process Controllers PID, Dual SET (SET + Alarm)



- ESM-4430** (48x48mm DIN 1/16)
- ESM-4930** (96x48mm DIN 1/8)
- ESM-7730** (72x72mm DIN 1/8)
- ESM-9930** (96x96mm DIN 1/4)
- ESM-9430** (48x96mm DIN 1/8)

- 4 digits process (PV) and 4 digits process set (SV) display
- Universal process input (TC, RTD, mV, V, mA)
- Dual or multi point calibration for Voltage / Current input
- Configurable ON/OFF, P, PI, PD ve PID control forms
- Auto-tune and Self-tune PID
- Manual/Automatic mode selection for control outputs
- Bumpless transfer
- Programmable heating, cooling and alarm functions for control outputs

ESM series process controllers are designed for measuring and controlling temperature and any process value. They can be used in many applications with their universal process input, control outputs, selectable alarm functions. They are mainly used in glass, plastic, petro-chemistry, textile, automotive and machine production industries. Sensitive and developed controlling is done with its selectable ON-OFF, P, PI, PD, PID, AutoTune and Self Tune PID properties.

SPECIFICATIONS

PROCESS INPUT

Universal Input: TC, RTD, Voltage/Current

Thermocouple (TC): L(DIN 43710), J, K, R, S, T, B, E and N (IEC584.1)(ITS90), C (ITS90)

Thermoresistance (RTD): PT-100 (IEC751)(ITS90)

Input: mV, V, mA

Measurement Range: Please refer to Table-1 for selection of input type and scale

Accuracy: ± 0.25% of full scale for thermocouple, thermoresistance, mV, V

± 0.70% of full scale for mA input

Cold Junction Compensation: Automatically ± 0.1°C/1°C

Line Compensation: Maximum 10 Ohm

Sensor break protection: Upscale

Sampling Cycle: 3 samples per second

Input Filter: 0.0 to 900.0 seconds

CONTROL

Control Form: ON/OFF, P, PI, PD or PID (Control form can be programmed by the user)

OUTPUTS

Standard Relay Outputs: Two relays. Their rating is 5A@250V~ (at resistive load) (They can be programmed as Control or Alarm output)
SSR Driver Output: Maximum 20mA@18V==

SUPPLY VOLTAGE

100-240V~ 50/60 Hz (-15%;+10%) -6VA Universal
 24V~ 50/60 Hz (-15% ; +10%) -6VA Optional
 24V==(-15% ; +10%) -6W Optional
 (Must be determined in order)

ENVIRONMENTAL RATINGS and PHYSICAL SPECIFICATIONS

Operating Temperature: 0...50°C
Humidity: 0-90%RH (none condensing)
Protection Class: IP65 at front, IP20 at rear
Dimensions:
 ESM-4430 : (48 x 48mm, Depth:87.5 mm)
 ESM-4930 : (96 x 48mm, Depth:86.5 mm)
 ESM-7730 : (72 x 72mm, Depth:87.5 mm)
 ESM-9930 : (96 x 96mm, Depth:87.5 mm)
 ESM-9430 : (48 x 96mm, Depth:86.5 mm)

ELECTRICAL WIRING

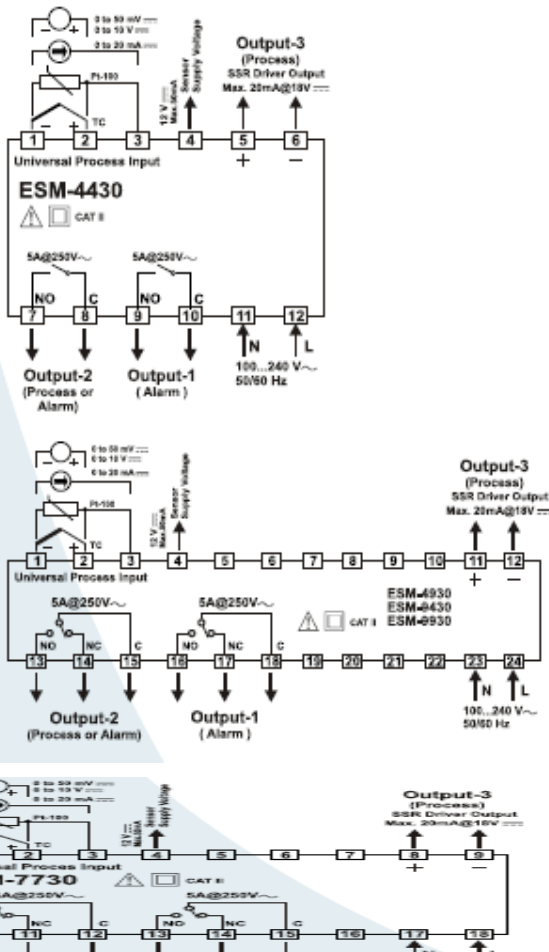

ORDERING INFORMATION

ESM-4430	(48x48 DIN 1/16)
ESM-4930	(96x48 DIN 1/8)
ESM-7730	(72x72 DIN Size)
ESM-9930	(96x96 DIN 1/4)
ESM-9430	(48x96 DIN 1/8)

A	BC	D	E	/	FG	HI	/	U	V	W	Z
		0	1	/	01	02	/	0	0	0	0

A	Supply Voltage
1	100-240V ~ (-15%;+10%) 50/60Hz
2	24V ~ (-15%;+10%) 50/60Hz 24V == (-15%;+10%)
9	Customer

BC	Input Type	Scale
20	Configurable(Table-1)	Table-1

D	Serial Communication
0	None

E	Output-1 (Alarm)
1	Relay Output (5A@250V~ at resistive load)

FG	Output-2 (Process or Alarm)
01	Relay Output (5A@250V~ at resistive load)

HI	Output-3 (Process)
02	SSR Driver Output (Maximum 20mA@18V ==)

Table-1

BC	Input Type(TC)	Scale(°C)	Scale(°F)
21	L,Fe Const DIN43710	-100°C,850°C	-148°F,1562°F
22	L,Fe Const DIN43710	-100.0°C,850.0°C	-148.0°F,999.9°F
23	J,Fe CuNi IEC584.1(ITS90)	-200°C,900°C	-328°F,1652°F
24	J,Fe CuNi IEC584.1(ITS90)	-199.9°C,900.0°C	-199.9°F,999.9°F
25	K,NiCr Ni IEC584.1(ITS90)	-200°C,1300°C	-328°F,2372°F
26	K,NiCr Ni IEC584.1(ITS90)	-199.9°C,999.9°C	-199.9°F,999.9°F
27	R,Pt13%Rh Pt IEC584.1(ITS90)	0°C,1700°C	32°F,3092°F
28	S,Pt10%Rh Pt IEC584.1(ITS90)	0°C,1700°C	32°F,3092°F
29	T,Cu CuNi IEC584.1(ITS90)	-200°C,400°C	-328°F,752°F
30	T,Cu CuNi IEC584.1(ITS90)	-199.9°C,400.0°C	-199.9°F,752.0°F
31	B,Pt30%Rh Pt6%Rh IEC584.1(ITS90)	44°C,1800°C	111°F,3272°F
32	B,Pt30%Rh Pt6%Rh IEC584.1(ITS90)	44.0°C,999.9°C	111.0°F,999.9°F
33	E,NiCr CuNi IEC584.1(ITS90)	-150°C,700°C	-238°F,1292°F
34	E,NiCr CuNi IEC584.1(ITS90)	-150.0°C,700.0°C	-199.9°F,999.9°F
35	N,Nicrosil Nilil IEC584.1(ITS90)	-200°C,1300°C	-328°F,2372°F
36	N,Nicrosil Nilil IEC584.1(ITS90)	-199.9°C,999.9°C	-199.9°F,999.9°F
37	C, (ITS90)	0°C,2300°C	32°F,3261°F
38	C, (ITS90)	0.0°C,999.9°C	32.0°F,999.9°F

BC	Input Type(RTD)	Scale(°C)	Scale(°F)
39	PT 100, IEC751(ITS90)	-200°C,650°C	-328°F,1202°F
40	PT 100, IEC751(ITS90)	-199.9°C,650.0°C	-199.9°F,999.9°F

BC	Input Type(== Voltage and Current)	Scale
41	0...50 mV ==	-1999,9999
42	0...5 V ==	-1999,9999
43	0...10 V ==	-1999,9999
44	0...20 mA ==	-1999,9999
45	4...20 mA ==	-1999,9999