

Magnetic field sensor for pneumatic cylinders (magnetic-field immune) BIM-NST-AP6X-H1141/S34 W/O BKT

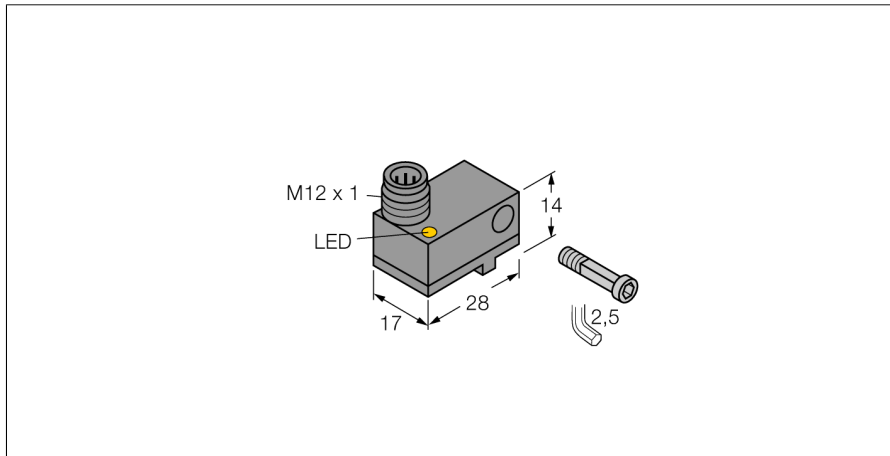

- Plastic, PA12-GF30
- Magnetic-inductive sensor
- Weld resistant to AC fields of 50...60 Hz
- DC 3-wire, 10...30 VDC
- NO contact, PNP output
- Male connector, M12 x 1

Wiring Diagram

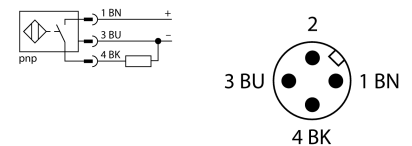

Functional principle

Magnetic field sensors are activated by magnetic fields and are used, in particular, for the detection of the piston position in pneumatic cylinders. As magnetic fields can permeate non-magnetizable metals, they detect a permanent magnet attached to the piston through the aluminium cylinder wall.

Weld-field immune permapprox sensors "freeze" the switching status when detecting a magnetic AC field (50...60 Hz). In this way, false switching operations are prevented during the welding process. When the AC field disappears, the sensors resume standard operation.

Type designation	BIM-NST-AP6X-H1141/S34 W/O BKT
Ident-No.	4685401
Ident-No (TUSA)	M4685401
Pass speed	≤ 1 m/s
Repeatability	≥ ± 0.1 mm
Temperature drift	≤ 0.1 mm
Hysteresis	≤ 1 mm
Ambient temperature	-25...+70 °C
Operating voltage	10...30 VDC
Residual ripple	≤ 10 % U _s
DC rated operational current	≤ 200 mA
No-load current I ₀	≤ 15 mA
Residual current	≤ 0.1 mA
Isolation test voltage	≤ 0.5 kV
Short-circuit protection	yes/ Cyclic
Voltage drop at I ₀	≤ 1.8 V
Wire breakage/Reverse polarity protection	yes/ Complete
Output function	3-wire, NO contact, PNP
Switching frequency	0.015 kHz
Design	Rectangular, NST
Dimensions	28 x 17 x 14 mm
Housing material	Plastic, PA12-GF30
Active area material	Plastic, PA12-GF30
Electrical connection	Connector, M12 x 1
Vibration resistance	55 Hz (1 mm)
Shock resistance	30 g (11 ms)
Protection class	IP67
MTTF	2283 years acc. to SN 29500 (Ed. 99) 40 °C
Mounting on the following profiles	.
Cylindrical design	
Switching state	LED yellow
Included in delivery	1 x screw M3x20, 1 x tension bolt, 1 x spring washer









**Magnetic field sensor
for pneumatic cylinders (magnetic-field immune)
BIM-NST-AP6X-H1141/S34 W/O BKT**

TURCK
works

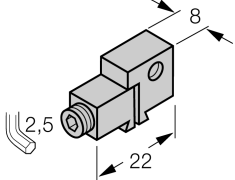
Industrial
Automation

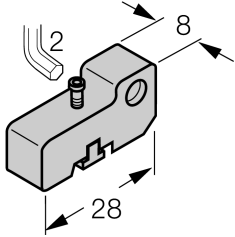
**Magnetic field sensor
for pneumatic cylinders (magnetic-field immune)
BIM-NST-AP6X-H1141/S34 W/O BKT**

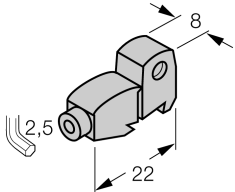
Accessories

Type code	Ident-No.	Description	
KLN-3 CLAMP	6970504	Mounting on  Dovetail groove cylinders or  T-groove cylinders; clamping width 5.2...13.5 mm; material: Anodized aluminium	
SMC-325	6970503	Mounting on  SMC cylinders; clamping width 4 mm; material: Anodized aluminium	
KLF-1	6970401	Mounting on  external dovetail grooves; for all cylinder diameters, material: Anodized aluminium	
KLF-2	6970402	Mounting on  external dovetail grooves (IMI Norgrem); for all cylinder diameters, material: Anodized aluminium	