

Proximity Inductive Sensors

Standard range, Nickel-Plated Brass Housing

Types ICB, M30

CARLO GAVAZZI



- Sensing distance: 10 to 15 mm
- Flush and non-flush types
- Short and long body versions
- Rated operational voltage (U_b): 10 - 36 VDC
- Output: DC 200 mA, NPN or PNP
- Normally open, Normally closed
- LED indication for output ON
- Protection: reverse polarity, short circuit, transients
- Cable and M12 plug versions
- According to IEC 60947-5-2
- CSA certified for Hazardous Locations

Product Description

A family of inductive proximity switches in industrial standard nickel-plated brass housings. They are able to handle applications where

high sensing range is requested. Output is open collector NPN or PNP transistors.

Ordering Key

ICB30SF10NOM1

Type _____
 Housing style _____
 Housing material _____
 Housing size _____
 Housing length _____
 Detection principle _____
 Sensing distance _____
 Output type _____
 Output configuration _____
 Connection _____

Type Selection

Connec- tion	Body style	Rated operating distance S_n	Ordering no. NPN Normally open	Ordering no. PNP Normally open	Ordering no. NPN Normally closed	Ordering no. PNP Normally closed
Cable	Short	10 mm ¹⁾	ICB 30 SF 10 NO	ICB 30 SF 10 PO	ICB 30 SF 10 NC	ICB 30 SF 10 PC
Cable	Short	15 mm ²⁾	ICB 30 SN 15 NO	ICB 30 SN 15 PO	ICB 30 SN 15 NC	ICB 30 SN 15 PC
Plug	Short	10 mm ¹⁾	ICB 30 SF 10 NOM1	ICB 30 SF 10 POM1	ICB 30 SF 10 NCM1	ICB 30 SF 10 PCM1
Plug	Short	15 mm ²⁾	ICB 30 SN 15 NOM1	ICB 30 SN 15 POM1	ICB 30 SN 15 NCM1	ICB 30 SN 15 PCM1
Cable	Long	10 mm ¹⁾	ICB 30 LF 10 NO	ICB 30 LF 10 PO	ICB 30 LF 10 NC	ICB 30 LF 10 PC
Cable	Long	15 mm ²⁾	ICB 30 LN 15 NO	ICB 30 LN 15 PO	ICB 30 LN 15 NC	ICB 30 LN 15 PC
Plug	Long	10 mm ¹⁾	ICB 30 LF 10 NOM1	ICB 30 LF 10 POM1	ICB 30 LF 10 NCM1	ICB 30 LF 10 PCM1
Plug	Long	15 mm ²⁾	ICB 30 LN 15 NOM1	ICB 30 LN 15 POM1	ICB 30 LN 15 NCM1	ICB 30 LN 15 PCM1

¹⁾ For flush mounting in metal

²⁾ For non-flush mounting in metal

Specifications

Rated operational voltage (U_b)	10 to 36 VDC (ripple incl.)	Indication for short circuit/ overload	LED blinking
Ripple	≤ 10%	Assured operating sensing distance (S_a)	$0 \leq S_a \leq 0.81 \times S_n$
Output current (I_o)	≤ 200 mA @ 50°C (≤ 150 mA @ 50-70°C)	Effective operating distance (S_r)	$0.9 \times S_n \leq S_r \leq 1.1 \times S_n$
OFF-state current (I_r)	≤ 50 μA	Usable operating distance (S_u)	$0.85 \times S_r \leq S_u \leq 1.1 \times S_r$
No load supply current (I_o)	≤ 15 mA	Repeat accuracy (R)	≤ 5%
Voltage drop (U_d)	Max. 2.5 VDC @ 200 mA	Differential travel (H) (Hysteresis)	1 to 20% of sensing dist.
Protection	Reverse polarity, short-circuit, transients	Ambient temperature	Operating Storage
Dielectric impulse voltage withstand	1 kV/0.5 J		-25° to +70°C (-13° to +158°F) -30° to +80°C (-22° to +176°F)
Power ON delay (t_v)	300 ms	Shock and vibration	IEC 60947-5-2/7.4
Operating frequency (f)	≤ 1000 Hz	Housing material	Body Front
Indication for output ON	Activated LED, yellow NO version Target present NC version Target not present		Nickel-plated brass Grey thermoplastic polyester



Specifications (cont.)

Connection Cable	2 m, 3 x 0.3 mm ² , grey PVC, oil proof
Plug	M12 x 1
Degree of protection	IP 67
Weight (cable/nuts included)	
ICB30 S	Max. 185 g
ICB30 L	Max. 195 g
Dimensions	See diagrams below
Tightening torque	25 Nm
Approvals	
UL (RU), CSA:	As Industrial Control Equipment - Proximity Switches. Types 1, 4, 4X or 12. Max ambient temperature 40°C.

Approvals (cont.)	
cCSAus	As Process Control Equipment for Hazardous Locations. - Class I, Division 2, Groups A, B, C and D. - Class I, Zone 1, AEx/Ex d IIB+H2, T5, Enclosure Type 4. Ambient temperature Ta: -25° to +60°C. Note: AEx for USA, Ex for Canada
CE-marking	Yes
EMC protection	According to IEC 60947-5-2
IEC 61000-4-2 (ESD)	8 KV air discharge, 4 KV contact discharge
IEC 61000-4-3	3 V/m
IEC 61000-4-4	2 kV
IEC 61000-4-6	3 V
IEC 61000-4-8	30 A/m

Dimensions

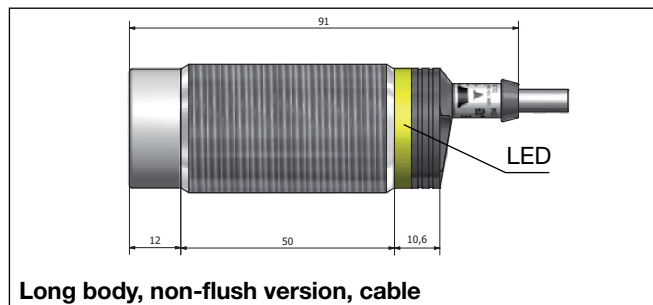
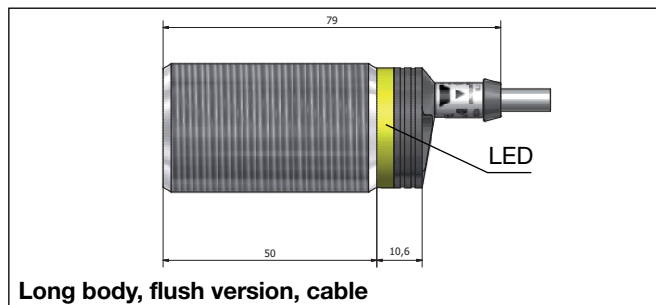
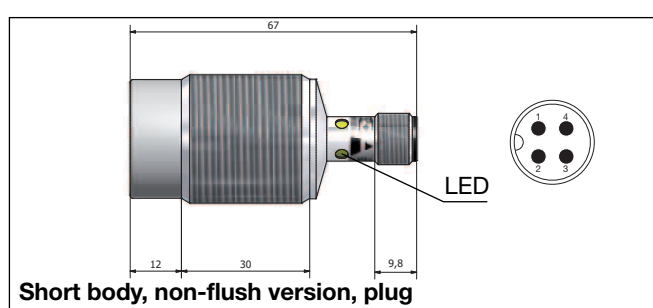
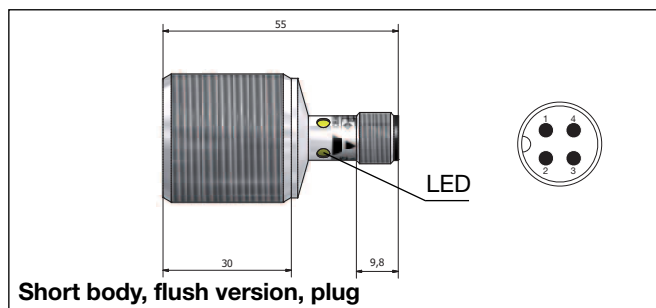
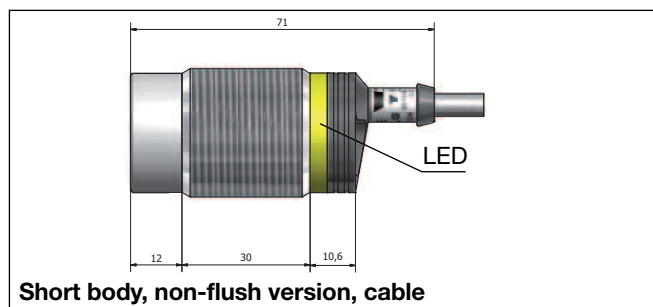
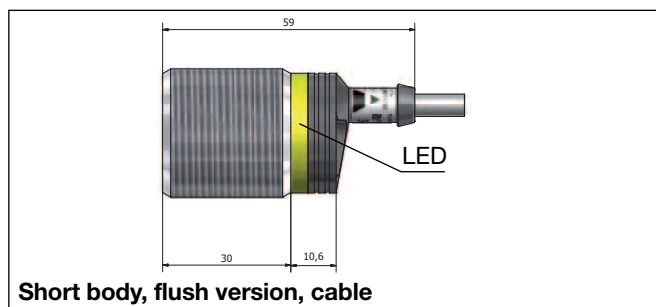

Dimensions (cont.)

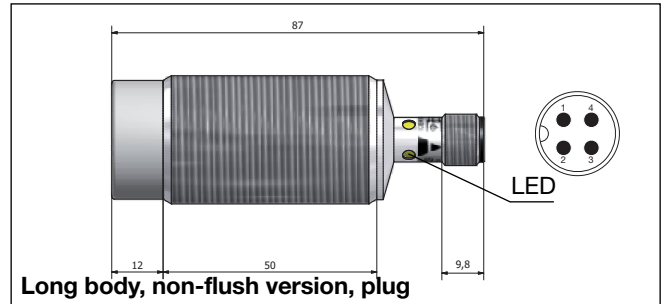
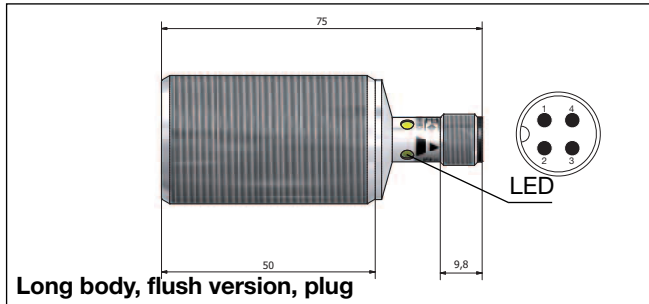

Installation

Flush sensor, when installed in damping material, must be according to Picture 1A.

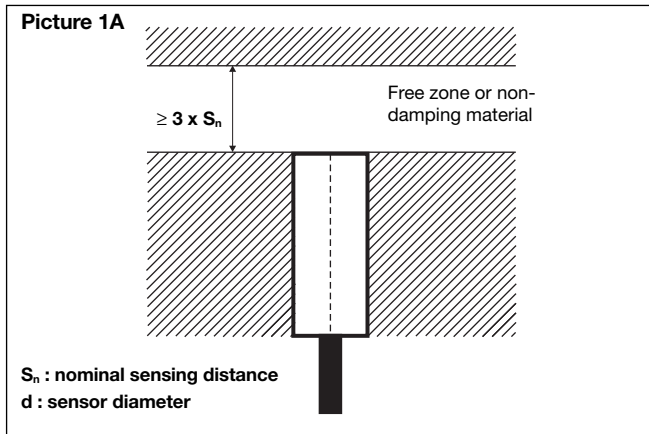

Non-flush sensor, when installed in damping material, must be according to Picture 1B.

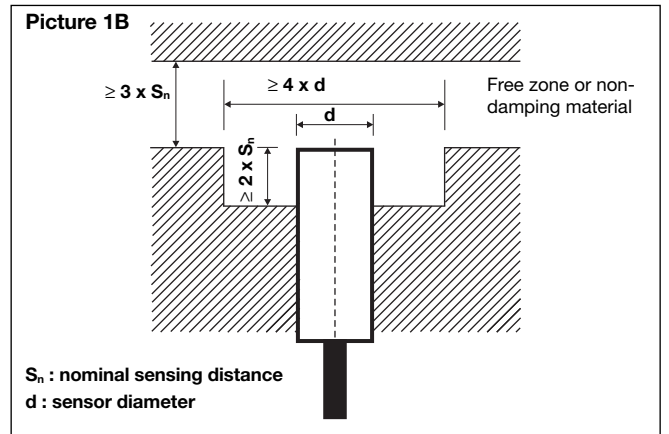

Flush sensors, when installed together in damping material, must be according to Picture 2A.

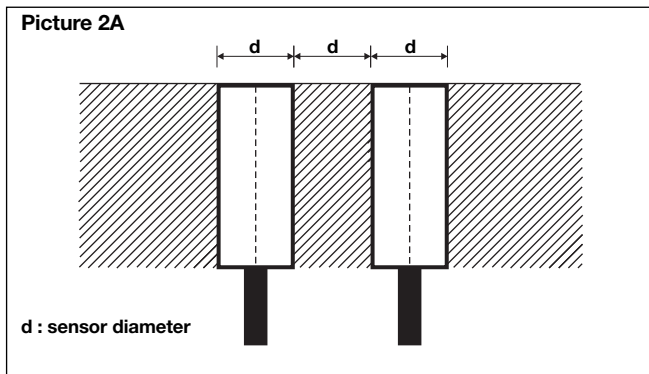

Non-flush sensors, when installed together in damping material, must be according to Picture 2B.

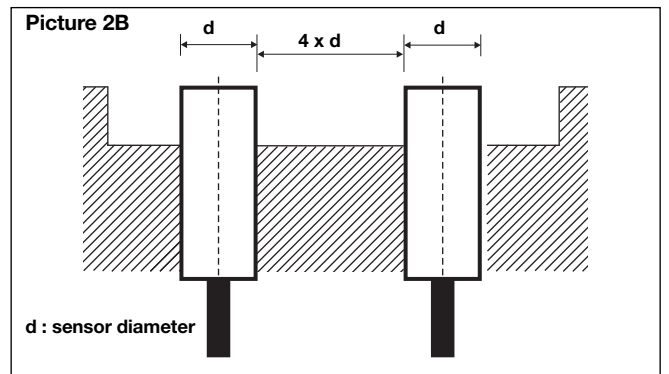

For sensors installed opposite each other, a minimum space of $6 \times S_n$ (the nominal sensing distance) must be observed (See Picture 3).

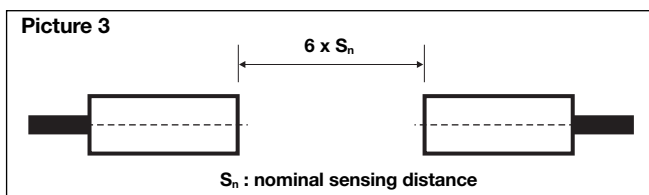



Wiring Diagrams

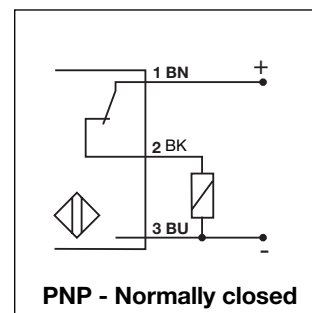
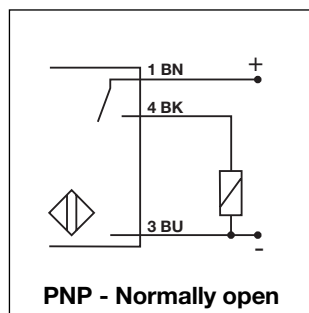
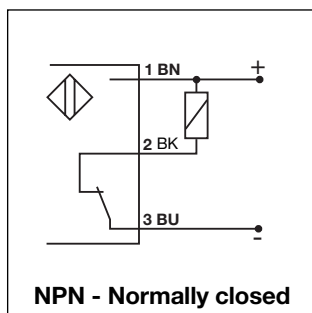
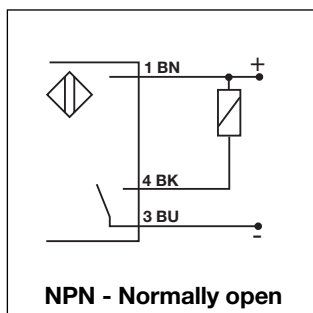

Reduction factors

The rated operating distance is reduced by the use of metals and alloys other than Fe360.

The most important reduction factors for inductive proximity sensors are shown in Picture 4.

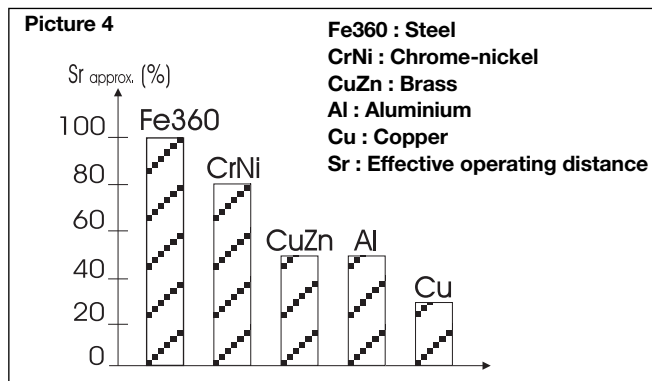

Accessories for Plug Versions

3-wire angled connector, 2 m cable	CONM13NF-A2
3-wire angled connector, 5 m cable	CONM13NF-A5
3-wire angled connector, 10 m cable	CONM13NF-A10
3-wire stright connector, 2m cable	CONM13NF-S2
3-wire stright connector, 5m cable	CONM13NF-S5

For any additional information or different options, please refer to the "General Accessories" datasheets.

Delivery Contents

- Inductive proximity switch ICB.
- 2 nuts NPB
- Packaging: plastic bag