

STRAIGHT PLUG CLAMP TYPE

R141.018.000

CABLE 10+11/50

Series : BNC

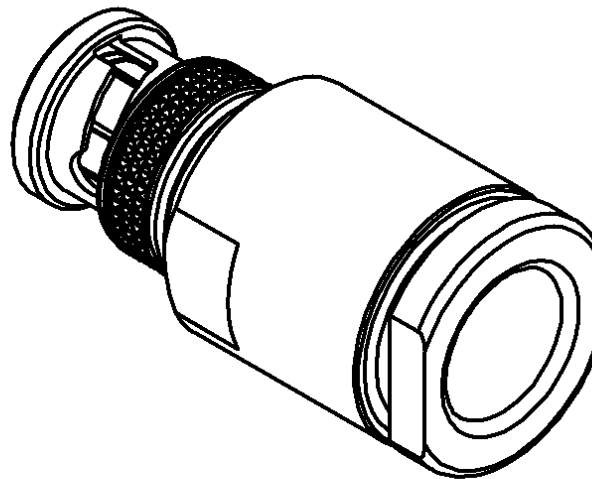
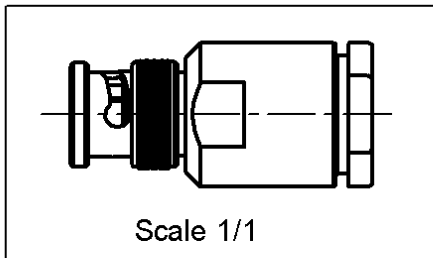
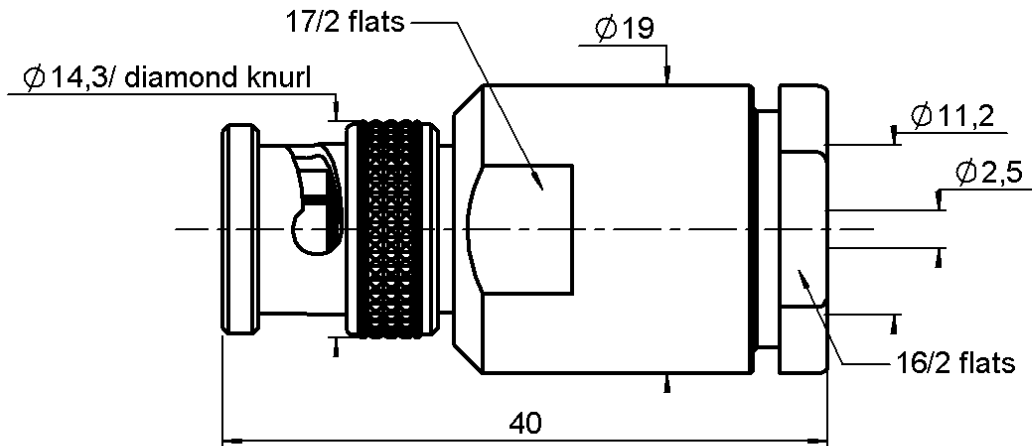

All dimensions are in mm.

COMPONENTS	MATERIALS	PLATING
BODY	BRASS	NICKEL 2 µm
CENTRE CONTACT	BRASS	GOLD 0.5 OVER NICKEL 2 µm
OUTER CONTACT	-	- µm
INSULATOR	PTFE	
GASKET	SILICONE RUBBER	
OTHERS PARTS	BRASS	NICKEL 2 µm
-	-	-
-	-	-



Issue : 9913 B

Design changes may be in order to improve the product.

STRAIGHT PLUG CLAMP TYPE

R141.018.000

CABLE 10+11/50

Series : **BNC**

ELECTRICAL CHARACTERISTICS

Impedance **50 Ω**
 Frequency **0-4 GHz**
 VSWR **1.1 + 0.000 x F(GHz) Maxi**
 Insertion loss **0.115 √F(GHz) dB**
 RF leakage - (**57 - F(GHz) dB mini**
 Voltage rating **500 Veff Maxi**
 Dielectric withstanding voltage **1500 Veff mini**
 Insulation resistance **5000 MΩ mini**

SPECIFICATION

Stripping	a	b	c	d	e	f
mm	9.00	1.00	10.0	0.00	4.00	0.00

Assembly instruction : **CLAMP 02**

Recommended cable(s)
 RG 225
 KX 13
 RG 393
 KX 4
 RG 213
 RG 214

Cable retention
 - pull off **350 N mini**
 - torque **NA N.cm**

MECHANICAL CHARACTERISTICS

Centre contact retention
 Axial force – Mating end **27 N mini**
 Axial force – Opposite end **27 N mini**
 Torque **NA N.cm mini**

TOOLING

Part Number	Description	Hexagon
.	.	.

Recommended torque
 Mating **NA N.cm**
 Panel nut **NA N.cm**
 Clamp nut **450 N.cm**
 A/F clamp nut **16.000 mm**

OTHERS CHARACTERISTICS

Mating life **500 Cycles mini**
 Weight **32.000 g**

ENVIRONMENTAL

Operating temperature **-65/+165 °C**
 Leakage – pressurised only **NA Atm.cm3/s**
 Hermetic seal **NA Mpa**

