

- Threaded barrel, M12x1
- Stainless steel, 1.4301
- Factor 1 for all metals
- Protection class IP68
- Magnetic field immune
- Extended temperature range
- High switching frequency
- Predamping protection through self-compensation
- DC 3-wire, 10...30 VDC
- NO contact, PNP output
- M12 x 1 connector

Type	NI8U-EM12E-AP6X2-H1141
Ident-No.	1644314
Rated operating distance Sn	8 mm
Mounting condition	non-flush, partially embeddable
Assured sensing range	≤ (0,81 x Sn) mm
Repeatability	≤ 2 %
Temperaturdrift	10 %
	≤ ± 20 %, ≤ -25 °C v ≥ +70 °C
Hysteresis	3...15 %
Ambient temperature	-30...+85 °C
Operating voltage	10...30VDC
Residual ripple	≤ 10 % U _{ss}
DC rated operational current	≤ 200 mA
No-load current I ₀	≤ 15 mA
Residual current	≤ 0.1 mA
Rated insulation voltage	≤ 0.5 kV
Short-circuit protection	yes/ cyclic
Voltage drop at I _e	≤ 1.8 V
Wire breakage / Reverse polarity protection	yes/ complete
Output function	3-wire, NO contact, PNP
Protection class	☐
Switching frequency	2 kHz
Design	threaded barrel, M12 x 1
Dimensions	62 mm
Housing material	Metal, V2A (1.4301)
Material active face	Plastic, PA12-GF30
Max. tightening torque housing nut	10 Nm
Connection	connector, M12 x 1
Vibration resistance	55 Hz (1 mm)
Shock resistance	30 g (11 ms)
Protection class	IP68
MTTF	874years acc. to SN 29500 (Ed. 99) 40 °C
Operating voltage	LED green
Switching state	LED yellow

Wiring diagram

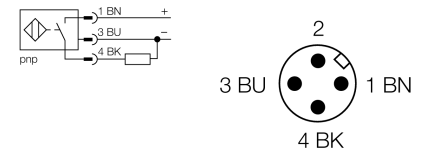

Functional principle

Inductive sensors detect metal objects contactless and wear-free. Due to the patented ferrite-less 3-coil system, uprox® factor 1 sensors have distinct advantages compared to conventional sensors. They detect all metals at the same switching distance, are magnetic field immune and feature large switching distances.

**Inductive sensor
NI8U-EM12E-AP6X2-H1141**

Mounting instructions	minimum distances
Distance D	36 mm
Distance W	24 mm
Distance T	45 mm
Distance S	0.5 x B
Distance G	48 mm
Distance N	16 mm

Diameter of the active area B Ø 12 mm

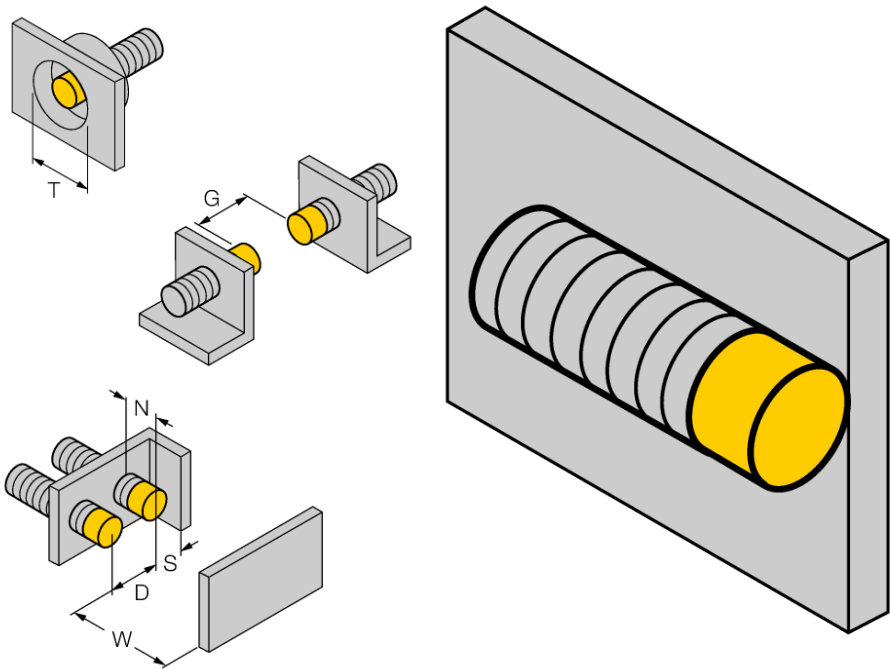

1-side flush mounting possible:
1-side flush mounting: Sr = 6 mm

Accessories

Type code	Ident-No.	Short text	Dimension drawing
BST-12B	6947212	Fixing clamp for threaded barrel devices, with dead-stop; material: PA6	
QM-12	6945101	Quick-mount bracket with dead-stop; material: Chrome-plated brass Male thread M16 x 1. Note: The switching distance of proximity switches can be reduced by the use of quick-mount brackets.	
MW-12	6945003	Mounting bracket for threaded barrel devices; material: Stainless steel A2 1.4301 (AISI 304)	
BSS-12	6901321	Mounting bracket for smooth and threaded barrel devices; material: Polypropylene	