

**Robert Bosch GmbH**  
Power Tools Division  
70745 Leinfelden-Echterdingen  
Germany

[www.bosch-pt.com](http://www.bosch-pt.com)

3 609 929 C57 (2012.11) 0 / 10 XXX



3 609 929 C57

## GGs Professional

28 CE | 28 LCE



cn 正本使用说明书



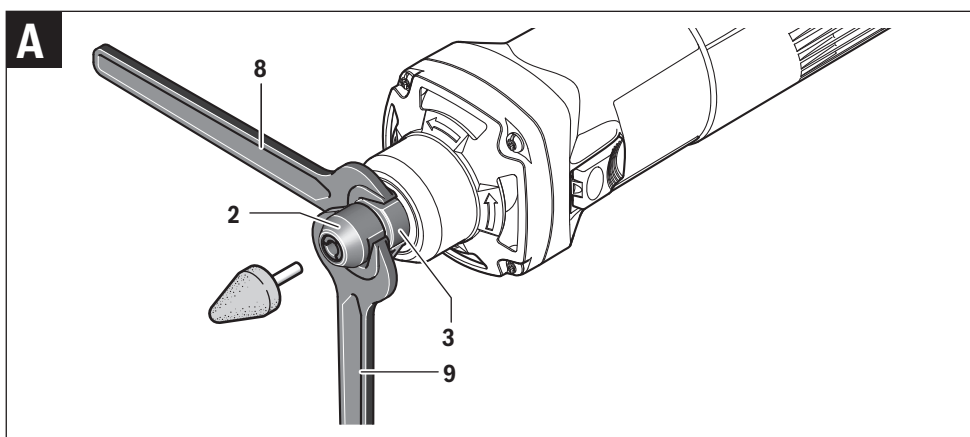
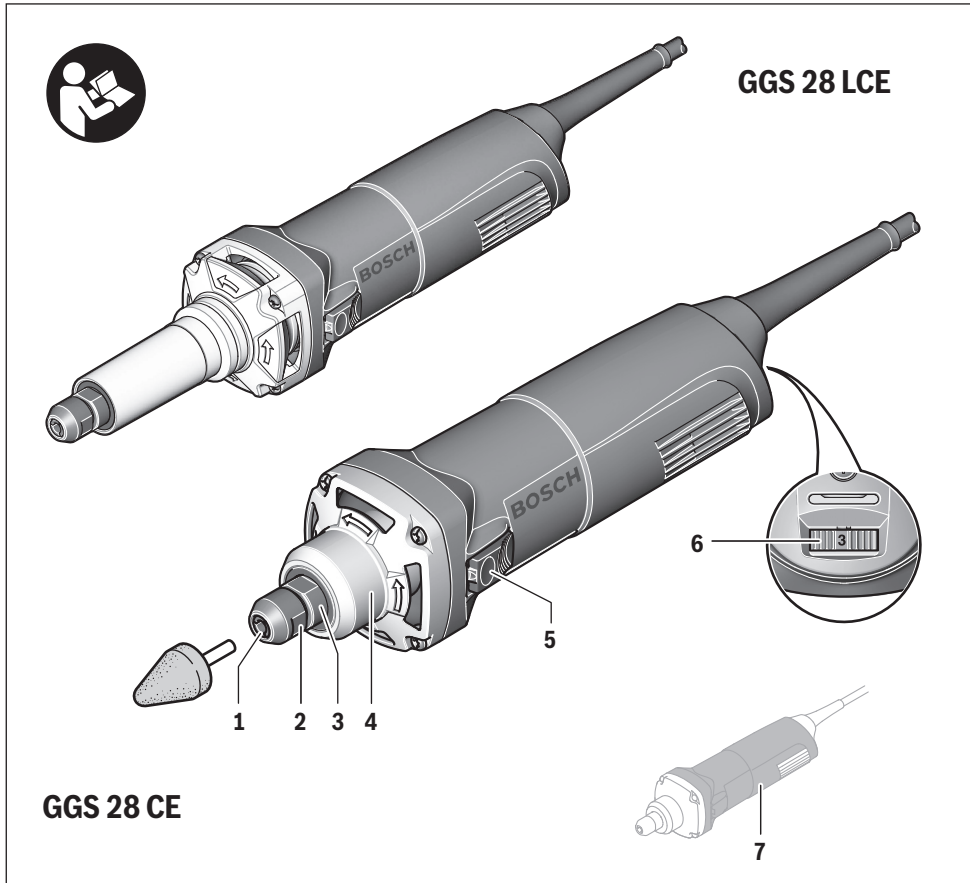

## 中文

### 安全规章

#### 电动工具通用安全警告

**警告** 阅读所有警告和所有说明！不遵照以下警告和说明会导致电击、着火和/或严重伤害。

保存所有警告和说明书以备查阅。

在所有下列的警告中术语“电动工具”指市电驱动（有线）电动工具或电池驱动（无线）电动工具。

#### 工作场地的安全

- ▶ 保持工作场地清洁和明亮。混乱和黑暗的场地会引发事故。
- ▶ 不要在易爆环境，如有易燃液体、气体或粉尘的环境下操作电动工具。电动工具产生的火花会点燃粉尘或气体。
- ▶ 让儿童和旁观者离开后操作电动工具。注意力不集中会使操作者失去对工具的控制。

#### 电气安全

- ▶ 电动工具插头必须与插座相配。绝不能以任何方式改装插头。需接地的电动工具不能使用任何转换插头。未经改装的插头和相配的插座将减少电击危险。
- ▶ 避免人体接触接地表面，如管道、散热片和冰箱。如果你身体接地会增加电击危险。
- ▶ 不得将电动工具暴露在雨或潮湿环境中。水进入电动工具将增加电击危险。
- ▶ 不得滥用电线。绝不能用电线搬运、拉动电动工具或拔出其插头。使电线远离热源、油、锐边或运动部件。受损或缠绕的软线会增加电击危险。
- ▶ 当在户外使用电动工具时，使用适合户外使用的外接软线。适合户外使用的软线将减少电击危险。
- ▶ 如果在潮湿环境下操作电动工具是不可避免的，应使用剩余电流动作保护器（RCD）。使用 RCD 可减少电击危险。

#### 人身安全

- ▶ 保持警觉，当操作电动工具时关注所从事的操作并保持清醒。当你感到疲倦，或在有药物、酒精或治疗反应时，不要操作电动工具。在操作电动工具时瞬间的疏忽会导致严重人身伤害。
- ▶ 使用个人防护装置。始终佩戴护目镜。安全装置，诸如适当条件下使用防尘面具、防滑安全鞋、安全帽、听力防护等装置能减少人身伤害。

- ▶ 防止意外起动。确保开关在连接电源和/或电池盒、拿起或搬运工具时处于关断位置。手指放在已接通电源的开关上或开关处于接通时插入插头可能会导致危险。
- ▶ 在电动工具接通之前，拿掉所有调节钥匙或扳手。遗留在电动工具旋转零件上的扳手或钥匙会导致人身伤害。
- ▶ 手不要伸展得太长。时刻注意立足点和身体平衡。这样在意外情况下能很好地控制电动工具。
- ▶ 着装适当。不要穿宽松衣服或佩戴饰品。让你的衣服、手套和头发远离运动部件。宽松衣服、佩饰或长发可能会卷入运动部件中。
- ▶ 如果提供了与排屑、集尘设备连接用的装置，要确保他们连接完好且使用得当。使用这些装置可减少尘屑引起的危险。

#### 电动工具使用和注意事项

- ▶ 不要滥用电动工具，根据用途使用适当的电动工具。选用适当设计的电动工具会使你工作更有效、更安全。
- ▶ 如果开关不能接通或关断工具电源，则不能使用该电动工具。不能用开关来控制的电动工具是危险的且必须进行修理。
- ▶ 在进行任何调节、更换附件或贮存电动工具之前，必须从电源上拔掉插头和/或使电池盒与工具脱开。这种防护性措施将减少工具意外起动的危险。
- ▶ 将闲置不用的电动工具贮存在儿童所及范围之外，并且不要让不熟悉电动工具或对这些说明不了解的人操作电动工具。电动工具在未经培训的用户手中是危险的。
- ▶ 保养电动工具。检查运动件是否调整到位或卡住，检查零件破损情况和影响电动工具运行的其他状况。如有损坏，电动工具应在使用前修理好。许多事故由维护不良的电动工具引发。
- ▶ 保持切削刀具锋利和清洁。保养良好的有锋利切削刃的刀具不易卡住而且容易控制。
- ▶ 按照使用说明书，考虑作业条件和进行的作业来使用电动工具、附件和工具的刀头。将电动工具用于那些与其用途不符的操作可能会导致危险。

#### 维修

- ▶ 将你的电动工具送交专业维修人员，使用同样的备件进行修理。这样将确保所维修的电动工具的安全性。

#### 针对直磨机安全规章

##### 研磨和建模的共同安全规章：

- ▶ 本电动工具可以充当研磨机和建模机。遵循电动工具供货时一并提供的所有安全规章，指示，描述和数据。如果未遵循以下的指示，可能造成电击，火灾和/或严重的伤害。

## 4 | 中文

- ▶ **本电动工具不适合进行砂纸研磨，钢丝刷研磨，抛光和切割研磨。** 未依照规定使用机器可能危害他人或伤害自己。
- ▶ **不使用非工具制造商推荐和专门设计的附件。** 否则该附件可能被装到你的电动工具上，而它不能保证安全操作。
- ▶ **附件的额定速度必须至少等于电动工具上标出的最大速度。** 附件以比其额定速度大的速度运转会发生爆裂和飞溅。
- ▶ **附件的外径和厚度必须在电动工具额定能力范围之内。** 不正确的附件尺寸会造成操作失控。
- ▶ **砂轮、法兰盘、靠背垫或任何其他附近的轴孔尺寸必须适合于安装到电工具的主轴上。** 带轴孔的、与电动工具安装件不配的附件将会失稳、过度振动并会引起失控。
- ▶ **如果把砂轮，研磨体，研磨工具或其他附件安装在心棒上，必须把心棒完全地插入夹钳或夹头中。** "突出的部位" 或者说从夹钳到砂轮的距离，必须维持在最小。如果未固定好心棒和 / 或夹钳到砂轮的距离过大，安装在心棒上的砂轮可能松脱，并以极高的速度被抛离。
- ▶ **不要使用损坏的附件。在每次使用前要检查附件，** 例如砂轮是否有碎片和裂缝，靠背垫是否有裂缝、撕裂或过度磨损，钢丝刷是否松动或金属丝是否断裂。如果电动工具或附件脱落了，检查是否有损坏或安装没有损坏的附件。检查和安装附件后，让自己和旁观者的位置远离旋转附件的平面，并以电动工具最大空载速度运行 1 分钟。损坏的附件通常在该试验时会碎裂。
- ▶ **戴上防护用品。根据适用情况，使用面罩，安全护目镜或安全眼镜。适用时，戴上防尘面具，听力保护器，手套和能挡小磨料或工件碎片的工作围裙。** 眼防护罩必须挡住各种操作产生的飞屑。防尘面具或口罩必须能够过滤操作产生的颗粒。长期暴露在高强度噪音中会引起失聪。
- ▶ **让旁观者与工作区域保持一安全距离。任何进入工作区域的人必须戴上防护用品。** 工件或破损附件的碎片可能会飞出并引起紧靠着操作区域的旁观者的伤害。切割附件触及带电导线会使电动工具外露的金属零件带电，并使操作者触电。
- ▶ **当在切割附件有可能切割到暗线或自身电线的场所进行操作时，只能通过绝缘握持面来握住电动工具。** 切割附件碰到一根带电导线可能会使电动工具外露的金属零件带电并使操作者发生电击危险。
- ▶ **开动时务必要好好地握牢电动工具。** 开机后当转速达到最高时，马达的作用扭力可能导致电动工具打转。
- ▶ **可能的话要使用老虎钳固定好工件。千万不可以用一只手握着小的工件，而使用另外一只手操作电动工具。** 固定好小的工件之后，才能够空出双手好好地操控电动工具。切割圆的工件（例如木钉）棍

状物料或管子时，上述物料容易滚开，这样可能导致安装在机器上的磨具打滑并且朝着您抛射。

- ▶ **使软线远离旋转的附件。** 如果控制不当，软线可能被切断或缠绕，并使得你的手或手臂可能被卷入旋转附件中。
- ▶ **直到附件完全停止运动才放下电动工具。并且不得使用任何外力迫使金刚石切割片停转。** 旋转的附件可能会抓住表面并拉动电动工具而让你失去对工具的控制。
- ▶ **更换磨具之后或进行完机器的设定之后，务必确定是否已经正确地拧紧夹紧螺母，夹头或其他固定件。** 固定零件如果松脱了会在无预警的情况下移动位置，并进而造成操作失控；未固定好的转动组件可能会被猛烈地甩开。
- ▶ **当携带电动工具时不要开动它。** 意外地触及旋转附件可能会缠绕你的衣服而使附件伤害身体。
- ▶ **经常清理电动工具的通风口。** 电动机风扇会将灰尘吸进机壳，过多的金属粉末沉积会导致电气危险。
- ▶ **不要在易燃材料附近操作电动工具。** 火星可能会点燃这些材料。
- ▶ **不要使用需用冷却液的附件。** 用水或其他冷却液可能导致电腐蚀或电击。

## 反弹和相关警告

- ▶ **反弹是因卡住或缠绕住的旋转砂轮，靠背垫，钢丝刷或其他附件而产生的突然反作用力。** 卡住或缠绕会引起旋转附件的迅速堵转，随之使失控的电动工具在卡住点产生与附件旋转方向相反的运动。  
例如，如果砂轮被工件缠绕或卡住了，伸入卡住点的砂轮边缘可能会进入材料表面而引起砂轮爬出或反弹。砂轮可能飞向或飞离操作者，这取决于砂轮在卡住点的运动方向。在此条件下砂轮也可能碎裂。  
反弹是电动工具误用和 / 或不正确操作工序或条件的结果。可以通过采取以下给出的适当预防措施得以避免。
- ▶ **保持紧握电动工具，使你的身体和手臂处于正确状态以抵抗反弹力。如有辅助手柄，则要一直使用，以便最大限度控制住起动机时的反弹力或反力矩。** 如采取合适的预防措施，操作者就可以控制反力矩或反弹力。
- ▶ **绝不能将手靠近旋转附件。** 附件可能会反弹碰到手。
- ▶ **不要站在发生反弹时电动工具可能移动到的地方。** 反弹将在缠绕点驱使工具逆砂轮运动方向运动。
- ▶ **当在尖角、锐边等处作业时要特别小心。避免附件的弹跳和缠绕。** 尖角，锐边和弹跳具有缠绕旋转附件的趋势并引起反弹的失控。
- ▶ **不要安装上锯链、木雕刀片或带齿锯片。** 这些锯片会产生频繁的反弹和失控。

- ▶ **将磨具推入工件时的方向必须一致，也就是要以磨具离开工件时的方向来进行下一次的切入（相当于废屑被抛出的方向）。**如果电动工具的操作方向错误了，磨具会从工件上滑出，而且电动工具也会被拉向那个方向。
- ▶ **使用切割片，高速铣刀或硬金属铣刀时务必要固定好工件。**只要在铣槽中稍有歪斜，以上提到的安装件便会被卡住，并且可能造成反弹。如果切割片被卡住了，一般情况下切割片会破裂。钢制的锯刀，高速铣刀或硬金属铣刀如果卡住了，可能会从割槽中弹跳出来，并让操作者无法控制电动工具。

#### 研磨时的特殊安全指示

- ▶ **只使用所推荐的砂轮型号和为选用砂轮专门设计的护罩。**不是为电动工具设计的砂轮不能充分得到防护，是不安全的。
- ▶ **安装弯曲的砂轮时，砂轮的研磨面不可以突出于防护罩缘之外。**防护罩无法遮蔽因为安装不当而突出于防护罩缘之外的砂轮。
- ▶ **防护必须牢固地装在电动工具上，且放置得最具安全性，只有最小的砂轮部分暴露在操作人面前。**护罩帮助操作者免于受到爆裂砂轮片和偶然触及砂轮的危險。
- ▶ **砂轮只用作推荐的用途。例如：不要用切割砂轮的侧面进行磨削。**施加到砂轮侧面的力可能会使其碎裂。
- ▶ **始终为所选砂轮选用未损坏的，有恰当规格和形状的砂轮法兰盘。**合适的砂轮法兰盘支承砂轮可以减小砂轮破裂的可能性。切割砂轮的法兰盘可以不同于砂轮法兰盘。
- ▶ **不要使用从大规格电动工具上用剩的磨损砂轮。**用于大规格电动工具上的砂轮不适用于较小规格工具的高速工况并可能会爆裂。

#### 其它的警告事项



请佩戴护目镜。

- ▶ **使用合适的侦测装置侦察隐藏的电线，或者向当地的相关单位寻求支援。**接触电线可能引起火灾并让操作者触电。损坏了瓦斯管会引起爆炸。凿穿水管不仅会造成严重的财物损失，也可能导致触电。
- ▶ **如果电源突然中断，例如停电或不小心中断，得马上解除起停开关的锁定并把它设定在关闭的位置。**这样可以避免机器突然启动。
- ▶ **在研磨/割片尚未冷却之前，切勿紧握研磨/割片。**工作时切割片会变得非常炙热。
- ▶ **固定好工件。**使用固定装置或老虎钳固定工件，会比用手紧握工件更牢固。

## 产品和功率描述



阅读所有的警告提示和指示。如未确实遵循警告提示和指示，可能导致电击，火灾并且 / 或其他的严重伤害。

#### 按照规定使用机器

安装了金刚砂砂轮后，可以使用本电动工具研磨金属和磨削金属上的毛边。也可以在本机器上安装磨削砂带来进行研磨。

#### 插图上的机件

机件的编号和电动工具详解图上的编号一致。

- 1 夹钳
- 2 夹紧螺母
- 3 主轴
- 4 主轴颈
- 5 起停开关
- 6 设定转速的指拨轮
- 7 手柄（绝缘握柄）
- 8 主轴上的开口扳手\*
- 9 夹紧螺母上的开口扳手\*

\*图表或说明上提到的附件，并不包含在基本的供货范围中。本公司的附件清单中有完整的附件供应项目。

## 技术数据

直磨机	GG5 ...	28 CE	28 LCE
物品代码	3 601 ...	B20 1..	B21 1..
额定输入功率	瓦	650	650
输出功率	瓦	380	380
额定转速	次 / 分	28000	28000
转速设定范围	次 / 分	10000 - 28000	10000 - 28000
最大夹钳直径	毫米	8	8

本说明书提供的参数是以 230 V 为依据，于低电压地区，此数据有可能不同。

## 6 | 中文

直磨机	GG5 ...	28 CE	28 LCE
扳手安装位置			
- 夹紧螺母	毫米	19	19
- 主轴	毫米	19	13
主轴颈直径	毫米	43	43
最大砂轮直径	毫米	50	50
恒定电子装置		●	●
设定转速		●	●
重量符合 EPTA-Procedure 01/2003	公斤	1,4	1,6
绝缘等级		□/II	□/II

本说明书提供的参数是以 230 V 为依据，于低电压地区，此数据有可能不同。

## 噪音 / 震动值

噪音测量值符合 EN 60745.

GG5 ...		28 CE	28 LCE
本电动工具的 A 类 - 加权噪音水平通常为	分贝		
声压水平	分贝		
声功率水平		78	77
不确定系数 K =	分贝	89	88
<b>佩戴护耳罩!</b>		3	3
振动总值 $a_h$ (三向矢量和) 和不确定系数 K 是根据 EN 60745 的规定测得:			
表面研磨 (使用直径 25 毫米的砂轮粗磨):			
$a_h$	米 / 秒 <sup>2</sup>	3	6
K	米 / 秒 <sup>2</sup>	1,5	1,5
振动总值 $a_h$ (三向矢量和) 和不确定系数 K 是根据 EN 60745 的规定测得:			
表面研磨 (使用直径 50 毫米的砂轮粗磨):			
$a_h$	米 / 秒 <sup>2</sup>	8	14
K	米 / 秒 <sup>2</sup>	1,5	1,5

本使用说明书中提供的震动水平，是根据 EN 60745 中规定的测量方式所测得。因此可以做为电动工具之间的比较标准。也可以拿来大概地评估震动负荷。此震动值是电动工具从事正式用途时的震动水平。如果未按照规定使用电动工具，在电动工具上安装了不合适的工具，或者未确实做好维修的工作，都可能改变机器的震动水平，这样长期工作下来会明显地提高震动负荷。

为了准确地评估震动负荷还必须考虑到关机的时间，以及开机后尚未正式工作之前的待命时间。这些因素都会明显降低整个工作过程的震动负荷。

重要的是，额外地加强保护操作者免受震动伤害的安全防范措施，例如：做好电动工具以及安装工具的维修工作，工作时手部保持温暖，正确地安排工作的流程等。

合格声明 

本公司声明并保证，本公司产品以及与产品有关的“技术数据”都符合以下的标准或文件的规定 根据 2011/65/EU, 2004/108/EG, 2006/42/EG 制定的 EN 60745 标准。

技术文件 (2006/42/EG) 存放在：

Robert Bosch GmbH, PT/ETM9,  
D-70745 Leinfelden-Echterdingen

Dr. Egbert Schneider                      Helmut Heinzlmann  
Senior Vice President                      Head of Product Certification  
Engineering                                      PT/ETM9

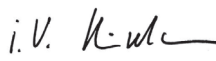
 i.V. 

Robert Bosch GmbH, Power Tools Division  
D-70745 Leinfelden-Echterdingen  
08.11.2012

## 安装

- ▶ **维修电动工具或换装零、配件之前，务必从插座上拔出插头。**

### 安装磨具（参考插图 A）

- ▶ **只能使用合适而且完好的开口扳手（参考“技术数据”）。**
  - 清洁主轴 3 和所有即将安装的零件。
  - 把开口扳手 8 插入扳手的插放位置，以便固定主轴 3。
    - 朝着逆时针的转向拧转插在扳手插放位置上的开口扳手 9，以拧鬆夹紧螺母 2。
  - 把砂轮的固定柄插入夹钳 1 中，并将它向内推压到尽头。
  - 把开口扳手 8 插入扳手的插放位置，以便固定主轴 3。朝着顺时针的转向拧转插在扳手插放位置上的开口扳手 9，以夹紧工具。

研磨体必须能够无暇且均匀地旋转。不可以继续使用已经变形的研磨体，必须马上更换变形的研磨体。

- ▶ **在尚未安装砂轮时，切勿拧紧安装着夹紧螺母的夹钳。否则会损坏夹钳。**

### 吸锯尘 / 吸锯屑

- ▶ 含铅的颜料以及某些木材、矿物和金属的加工废尘有害健康。机器操作者或者工地附近的人如果接触、吸入这些废尘，可能会有过敏反应或者感染呼吸道疾病。

某些尘埃（例如加工橡木或山毛榉的废尘）可能致癌，特别是和处理木材的添加剂（例如木材的防腐剂等）结合之后。只有经过专业训练的人才能够加工含石棉的物料。

- 工作场所要保持空气流通。
- 最好佩戴 P2 滤网等级的口罩。

请留心并遵守贵国和加工物料有关的法规。

- ▶ **避免让工作场所堆积过多的尘垢。尘埃容易被点燃。**

## 操作

### 操作机器

- ▶ **注意电源的电压！电源的电压必须和电动工具铭牌上标示的电压一致。**

#### 开动 / 关闭

**开动** 电动工具时，必须向前推移起停开关 5。

按下起停开关 5 的前端并让开关卡在这个位置，便可以 **固定** 起停开关 5。

放开起停开关 5 即可 **关闭** 电动工具。如果开关被固定了，可以先按下起停开关 5 的后端并随即放开。

### 回击 - 关闭功能

如果机器的转速突然降低，例如切割片被堵住了，传往发动机的电流会被切断。

**再度开动**，先关闭起停开关 5，然后再重新开动机器。

### 恒定电子装置

不论机器处在负载或空载状态，恒定电子装置都能够稳定转速，确保一致的工作效率。

### 设定转速

使用转速调整轮 6，即使在机器运作当中也可以设定须要的转速。

需要的转速取决于工件的材料和安装件的直径。务必遵循安装件的最大许可转速。

指拨轮的位置	无负载转速 (分 <sup>-1</sup> )
1	10000
2	12700
3	16700
4	19700
5	23500
6	28000

### 有关操作方式的指点

轻轻施压并均匀地来回移动磨具，如此能够获得最佳的工作效果。如果过度加压，不仅会降低电动工具的功率，而且会加速磨具的耗损率。

## 维修和服务

### 维修和清洁

- ▶ **维修电动工具或换装零、配件之前，务必从插座上拔出插头。**
- ▶ **电动工具和通风间隙都必须保持清洁，这样才能够提高工作品质 and 安全性。**
- ▶ **在某些极端的操作环境下，如果可能的话一定要使用吸尘装备。吹除通气孔中的污垢并且要使用剩余电流 - (FI) - 保护开关。**加工金属时可能在电动工具的内部堆积会导电的废尘。这样可能会影响电动工具的安全绝缘性能。

小心地保存和使用附件。

本公司生产的电动工具都经过严密的品质检验，如果机器仍然发生故障，请将机器交给博世电动工具公司授权的顾客服务处修理。

询问和订购备件时，务必提供机器铭牌上标示的 10 位数字物品代码。

## 8 | 中文

### 顾客服务处和顾客咨询中心

本公司顾客服务处负责回答有关本公司产品的修理、维护和备件的问题。以下的网页中有爆炸图和备件的资料：

**[www.bosch-pt.com](http://www.bosch-pt.com)**

博世顾客咨询团队非常乐意为您解答有关本公司产品及附件的问题。

有关保证，维修或更换零件事宜，请向合格的经销商查询。

#### 中国大陆

博世电动工具（中国）有限公司

中国 浙江省 杭州市

滨江区滨康路 567 号

邮政编码：310052

免费服务热线：4008268484

传真：(0571) 87774502

电邮：[contact.ptcn@cn.bosch.com](mailto:contact.ptcn@cn.bosch.com)

[www.bosch-pt.com.cn](http://www.bosch-pt.com.cn)

罗伯特·博世有限公司

香港北角英皇道 625 号 21 楼

客户服务热线：+852 2101 0235

传真：+852 2590 9762

电邮：[info@hk.bosch.com](mailto:info@hk.bosch.com)

网站：[www.bosch-pt.com.hk](http://www.bosch-pt.com.hk)

#### 制造商地址：

罗伯特博世有限公司

营业范围电动工具

邮箱号码 100156

70745 Leinfelden-Echterdingen (莱菲登 - 艾希德登)

Deutschland (德国)

### 处理废弃物

必须以符合环保的方式，回收再利用损坏的机器、附件和废弃的包装材料。

不可以把电动工具丢入家庭垃圾中！

**保留修改权。**

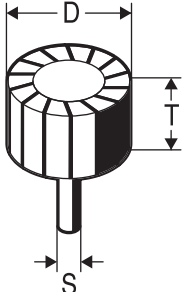

S	D	T	min <sup>-1</sup>	
3 mm				2 608 570 136
1/8"				2 608 570 139
6 mm				2 608 570 137
1/4"				2 608 570 140
8 mm				2 608 570 138

M 15	2 608 570 141
------	---------------

	1 607 929 000
--	---------------

  

S	D	T	min <sup>-1</sup>	
6 mm	15 mm	30 mm	36 000	2 608 620 034

**blue: Metal top**



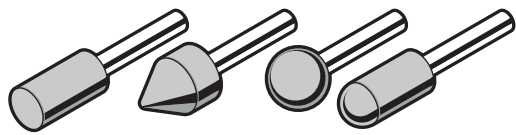

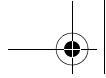
以下各页勿打印！

***Following pages  
are NOT for printing!***

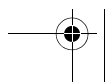
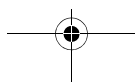
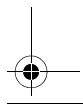
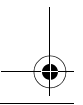
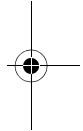
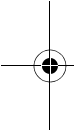

## English

### Safety Notes

#### General Power Tool Safety Warnings

**⚠ WARNING** Read all safety warnings and all instructions. Failure to follow the warnings and instructions may result in electric shock, fire and/or serious injury.

**Save all warnings and instructions for future reference.**

The term "power tool" in the warnings refers to your mains-operated (corded) power tool or battery-operated (cordless) power tool.

#### Work area safety

- ▶ **Keep work area clean and well lit.** Cluttered or dark areas invite accidents.
- ▶ **Do not operate power tools in explosive atmospheres, such as in the presence of flammable liquids, gases or dust.** Power tools create sparks which may ignite the dust or fumes.
- ▶ **Keep children and bystanders away while operating a power tool.** Distractions can cause you to lose control.

#### Electrical safety

- ▶ **Power tool plugs must match the outlet. Never modify the plug in any way. Do not use any adapter plugs with earthed (grounded) power tools.** Unmodified plugs and matching outlets will reduce risk of electric shock.
- ▶ **Avoid body contact with earthed or grounded surfaces, such as pipes, radiators, ranges and refrigerators.** There is an increased risk of electric shock if your body is earthed or grounded.
- ▶ **Do not expose power tools to rain or wet conditions.** Water entering a power tool will increase the risk of electric shock.
- ▶ **Do not abuse the cord. Never use the cord for carrying, pulling or unplugging the power tool. Keep cord away from heat, oil, sharp edges and moving parts.** Damaged or entangled cords increase the risk of electric shock.
- ▶ **When operating a power tool outdoors, use an extension cord suitable for outdoor use.** Use of a cord suitable for outdoor use reduces the risk of electric shock.
- ▶ **If operating a power tool in a damp location is unavoidable, use a residual current device (RCD) protected supply.** Use of an RCD reduces the risk of electric shock.

#### Personal safety

- ▶ **Stay alert, watch what you are doing and use common sense when operating a power tool. Do not use a power tool while you are tired or under the influence of drugs, alcohol or medication.** A moment of inattention while operating power tools may result in serious personal injury.
- ▶ **Use personal protective equipment. Always wear eye protection.** Protective equipment such as dust mask, non-skid safety shoes, hard hat, or hearing protection used for appropriate conditions will reduce personal injuries.

▶ **Prevent unintentional starting. Ensure the switch is in the off-position before connecting to power source and/or battery pack, picking up or carrying the tool.**

Carrying power tools with your finger on the switch or energising power tools that have the switch on invites accidents.

- ▶ **Remove any adjusting key or wrench before turning the power tool on.** A wrench or a key left attached to a rotating part of the power tool may result in personal injury.
- ▶ **Do not overreach. Keep proper footing and balance at all times.** This enables better control of the power tool in unexpected situations.
- ▶ **Dress properly. Do not wear loose clothing or jewellery. Keep your hair, clothing and gloves away from moving parts.** Loose clothes, jewellery or long hair can be caught in moving parts.
- ▶ **If devices are provided for the connection of dust extraction and collection facilities, ensure these are connected and properly used.** Use of dust collection can reduce dust-related hazards.

#### Power tool use and care

- ▶ **Do not force the power tool. Use the correct power tool for your application.** The correct power tool will do the job better and safer at the rate for which it was designed.
- ▶ **Do not use the power tool if the switch does not turn it on and off.** Any power tool that cannot be controlled with the switch is dangerous and must be repaired.
- ▶ **Disconnect the plug from the power source and/or the battery pack from the power tool before making any adjustments, changing accessories, or storing power tools.** Such preventive safety measures reduce the risk of starting the power tool accidentally.
- ▶ **Store idle power tools out of the reach of children and do not allow persons unfamiliar with the power tool or these instructions to operate the power tool.** Power tools are dangerous in the hands of untrained users.
- ▶ **Maintain power tools. Check for misalignment or binding of moving parts, breakage of parts and any other condition that may affect the power tool's operation. If damaged, have the power tool repaired before use.** Many accidents are caused by poorly maintained power tools.
- ▶ **Keep cutting tools sharp and clean.** Properly maintained cutting tools with sharp cutting edges are less likely to bind and are easier to control.
- ▶ **Use the power tool, accessories and tool bits etc. in accordance with these instructions, taking into account the working conditions and the work to be performed.** Use of the power tool for operations different from those intended could result in a hazardous situation.

#### Service

- ▶ **Have your power tool serviced by a qualified repair person using only identical replacement parts.** This will ensure that the safety of the power tool is maintained.

## Safety Warnings for Straight Grinders

### Safety Warnings Common for Grinding and Carving:

- ▶ **This power tool is intended to function as a grinder or carving tool. Read all safety warnings, instructions, illustrations and specifications provided with this power tool.** Failure to follow all instructions listed below may result in electric shock, fire and/or serious injury.
- ▶ **Operations such as sanding, wire brushing, polishing or cutting-off are not recommended to be performed with this power tool.** Operations for which the power tool was not designed may create a hazard and cause personal injury.
- ▶ **Do not use accessories which are not specifically designed and recommended by the tool manufacturer.** Just because the accessory can be attached to your power tool, it does not assure safe operation.
- ▶ **The rated speed of the accessory must be at least equal to the maximum speed marked on the power tool.** Accessories running faster than their rated speed can break and fly apart.
- ▶ **The outside diameter and the thickness of your accessory must be within the capacity rating of your power tool.** Incorrectly sized accessories cannot be adequately controlled.
- ▶ **Treaded mounting of accessories must match the grinder spindle thread. For accessories mounted by flanges, the arbour hole of the accessory must fit the locating diameter of the flange.** Accessories that do not match the mounting hardware of the power tool will run out of balance, vibrate excessively and may cause loss of control.
- ▶ **Mandrel mounted wheels, sanding drums, cutters or other accessories must be fully inserted into the collet or chuck. The "overhang" or the length of the mandrel from the wheel to the collet must be minimal.** If the mandrel is insufficiently held and/or the overhang of the wheel is too long, the mounted wheel may become loose and ejected at high velocity.
- ▶ **Do not use a damaged accessory. Before each use inspect the accessory such as abrasive wheels for chips and cracks, sanding drum for cracks, tear or excess wear, wire brush for loose or cracked wires. If power tool or accessory is dropped, inspect for damage or install an undamaged accessory. After inspecting and installing an accessory, position yourself and bystanders away from the plane of the rotating accessory and run the power tool at maximum no-load speed for one minute.** Damaged accessories will normally break apart during this test time.
- ▶ **Wear personal protective equipment. Depending on application, use face shield, safety goggles or safety glasses. As appropriate, wear dust mask, hearing protectors, gloves and workshop apron capable of stopping small abrasive or workpiece fragments.** The eye protection must be capable of stopping flying debris generated by various operations. The dust mask or respirator must be capable of filtrating particles generated by your operation. Prolonged exposure to high intensity noise may cause hearing loss.
- ▶ **Keep bystanders a safe distance away from work area. Anyone entering the work area must wear personal protective equipment.** Fragments of workpiece or of a broken accessory may fly away and cause injury beyond immediate area of operation.
- ▶ **Hold power tool by insulated gripping surfaces only, when performing an operation where the cutting accessory may contact hidden wiring or its own cord.** Cutting accessory contacting a "live" wire may make exposed metal parts of the power tool "live" and could give the operator an electric shock.
- ▶ **Always hold the tool firmly during the start-up.** The reaction torque of the motor, as it accelerates to full speed, can cause the tool to twist.
- ▶ **Use clamps to support workpiece whenever practical. Never hold a small workpiece in one hand and the tool in the other hand while in use.** Clamping a small workpiece allows you to use both hands to control the tool. Round material such as dowel rods, pipes or tubing have a tendency to roll while being cut, and may cause the bit to bind or jump toward you.
- ▶ **Position the cord clear of the spinning accessory.** If you lose control of the power tool, the cord may be cut or snagged and your hand or arm may be pulled into the spinning accessory.
- ▶ **Never lay the power tool down until the accessory has come to a complete stop.** The spinning accessory may grab the surface and pull the power tool out of your control.
- ▶ **After changing the bits or making any adjustments, make sure the collet nut, chuck or any other adjustment devices are securely tightened.** Loose adjustment devices can unexpectedly shift, causing loss of control, loose rotating components will be violently thrown.
- ▶ **Do not run the power tool while carrying it at your side.** Accidental contact with the spinning accessory could snag your clothing, pulling the accessory into your body.
- ▶ **Regularly clean the power tool's air vents.** The motor's fan will draw the dust inside the housing and excessive accumulation of powdered metal may cause electrical hazards.
- ▶ **Do not operate the power tool near flammable materials.** Sparks could ignite these materials.
- ▶ **Do not use accessories that require liquid coolants.** Using water or other liquid coolants may result in electrocution or shock.

### Kickback and related warnings

- ▶ Kickback is a sudden reaction to a pinched or snagged rotating wheel, backing pad, brush or any other accessory. Pinching or snagging causes rapid stalling of the rotating accessory which in turn causes the uncontrolled power tool to be forced in the direction opposite of the accessory's rotation at the point of the binding. For example, if an abrasive wheel is snagged or pinched by the workpiece, the edge of the wheel that is entering into the pinch point can dig into the surface of the material causing the wheel to climb out or kick out. The wheel may

#### 4 | English

either jump toward or away from the operator, depending on direction of the wheel's movement at the point of pinching. Abrasive wheels may also break under these conditions.

Kickback is the result of power tool misuse and/or incorrect operating procedures or conditions and can be avoided by taking proper precautions as given below.

- ▶ **Maintain a firm grip on the power tool and position your body and arm to allow you to resist kickback forces. Always use auxiliary handle, if provided, for maximum control over kickback or torque reaction during start-up.** The operator can control torque reactions or kickback forces, if proper precautions are taken.
- ▶ **Never place your hand near the rotating accessory.** Accessory may kickback over your hand.
- ▶ **Do not position your body in the area where power tool will move if kickback occurs.** Kickback will propel the tool in direction opposite to the wheel's movement at the point of snagging.
- ▶ **Use special care when working corners, sharp edges, etc. Avoid bouncing and snagging the accessory.** Corners, sharp edges or bouncing have a tendency to snag the rotating accessory and cause loss of control or kickback.
- ▶ **Do not attach a saw chain woodcarving blade or toothed saw blade.** Such blades create frequent kickback and loss of control.
- ▶ **Always feed the bit into the material in the same direction as the cutting edge is exiting from the material (which is the same direction as the chips are thrown).** Feeding the tool in the wrong direction causes the cutting edge of the bit to climb out of the work and pull the tool in the direction of this feed.
- ▶ **When using cut-off wheels, high-speed cutters or tungsten carbide cutters, always have the work securely clamped.** These wheels will grab if they become slightly canted in the groove, and can kickback. When a cut-off wheel grabs, the wheel itself usually breaks. When the steel saw, high-speed cutters or tungsten carbide cutter grab, it may jump from the groove and you could lose control of the tool.

#### Additional safety instructions for grinding

- ▶ **Use only wheel types that are recommended for your power tool and the specific guard designed for the selected wheel.** Wheels for which the power tool was not designed cannot be adequately guarded and are unsafe.
- ▶ **The grinding surface of the centre depressed wheels must be mounted below the plane of the guard lip.** An improperly mounted wheel that projects through the plane of the guard lip cannot be adequately protected.
- ▶ **The guard must be securely attached to the power tool and positioned for maximum safety, so the least amount of wheel is exposed towards the operator.** The guard helps to protect operator from broken wheel fragments, accidental contact with wheel and sparks that could ignite clothing.

- ▶ **Wheels must be used only for recommended applications. For example: do not grind with the side of the cut-off wheel.** Abrasive cut-off wheels are intended for peripheral grinding; side forces applied to these wheels may cause them to shatter.
- ▶ **Always use undamaged wheel flanges that are of correct size and shape for your selected wheel.** Proper wheel flanges support the wheel thus reducing the possibility of wheel breakage. Flanges for cut-off wheels may be different from grinding wheel flanges.
- ▶ **Do not use worn down wheels from larger power tools.** Wheels intended for larger power tools are not suitable for the higher speed of a smaller tool and may burst.

#### Additional safety warnings

**Wear safety goggles.**



- ▶ **Use suitable detectors to determine if utility lines are hidden in the work area or call the local utility company for assistance.** Contact with electric lines can lead to fire and electric shock. Damaging a gas line can lead to explosion. Penetrating a water line causes property damage or may cause an electric shock.
- ▶ **Release the On/Off switch and set it to the off position when the power supply is interrupted, e. g., in case of a power failure or when the mains plug is pulled.** This prevents uncontrolled restarting.
- ▶ **Do not touch grinding and cutting discs before they have cooled down.** The discs can become very hot while working.
- ▶ **Secure the workpiece.** A workpiece clamped with clamping devices or in a vice is held more secure than by hand.

## Product Description and Specifications



**Read all safety warnings and all instructions.** Failure to follow the warnings and instructions may result in electric shock, fire and/or serious injury.

#### Intended Use

The machine is designed for grinding and deburring metal using corundum grinding tools, as well as for working with sanding wheels.

#### Product Features

The numbering of the product features refers to the illustration of the machine on the graphics page.

- 1 Collet
- 2 Clamping nut
- 3 Grinder spindle

- 4 Spindle collar
- 5 On/Off switch
- 6 Thumbwheel for speed preselection
- 7 Handle (insulated gripping surface)

- 8 Open-end spanner on the grinder spindle\*
- 9 Open-end spanner applied to clamping nut\*

\*Accessories shown or described are not part of the standard delivery scope of the product. A complete overview of accessories can be found in our accessories program.

### Technical Data

Straight grinder	GGS ...	28 CE	28 LCE
Article number	3 601 ...	B20 1..	B21 1..
Rated power input	W	650	650
Output power	W	380	380
Rated speed	min <sup>-1</sup>	28000	28000
Speed control adjustment	min <sup>-1</sup>	10000 – 28000	10000 – 28000
Collet chuck diameter, max.	mm	8	8
Spanner size of			
– clamping nut	mm	19	19
– grinder spindle	mm	19	13
Spindle collar dia.	mm	43	43
Grinding tool diameter, max.	mm	50	50
Constant electronic control		●	●
Speed preselection		●	●
Weight according to EPTA-Procedure 01/2003	kg	1.4	1.6
Protection class		□/II	□/II
The values given are valid for a nominal voltage [U] of 230 V. For different voltages and models for specific countries, these values can vary.			

### Noise/Vibration Information

Measured sound values determined according to EN 60745.

GGS ...		28 CE	28 LCE
Typically the A-weighted noise levels of the product are			
Sound pressure level	dB(A)	78	77
Sound power level	dB(A)	89	88
Uncertainty K =	dB	3	3
<b>Wear hearing protection!</b>			
Vibration total values $a_h$ (triax vector sum) and uncertainty K determined according to EN 60745:			
Surface grinding (with wheel diameter of 25 mm):			
$a_h$	m/s <sup>2</sup>	3	6
K	m/s <sup>2</sup>	1.5	1.5
Vibration total values $a_h$ (triax vector sum) and uncertainty K determined according to EN 60745:			
Surface grinding (with wheel diameter of 50 mm (max.):			
$a_h$	m/s <sup>2</sup>	8	14
K	m/s <sup>2</sup>	1.5	1.5

The vibration emission level given in this information sheet has been measured in accordance with a standardised test given in EN 60745 and may be used to compare one tool with another. It may be used for a preliminary assessment of exposure.

The declared vibration emission level represents the main applications of the tool. However if the tool is used for different applications, with different accessories or poorly maintained, the vibration emission may differ. This may significantly increase the exposure level over the total working period.

An estimation of the level of exposure to vibration should also take into account the times when the tool is switched off or when it is running but not actually doing the job. This may significantly reduce the exposure level over the total working period.

Identify additional safety measures to protect the operator from the effects of vibration such as: maintain the tool and the accessories, keep hands warm, organise work patterns.

6 | English

## Declaration of Conformity

We declare under our sole responsibility that the product described under "Technical Data" is in conformity with the following standards or standardization documents: EN 60745 according to the provisions of the directives 2011/65/EU, 2004/108/EC, 2006/42/EC.

Technical file (2006/42/EC) at:  
Robert Bosch GmbH, PT/ETM9,  
D-70745 Leinfelden-Echterdingen

Dr. Egbert Schneider      Helmut Heinzlmann  
Senior Vice President      Head of Product Certification  
Engineering                      PT/ETM9

*Rpa. Schneider*      *i.v. Heinzlmann*

Robert Bosch GmbH, Power Tools Division  
D-70745 Leinfelden-Echterdingen  
08.11.2012

## Assembly

- ▶ **Before any work on the machine itself, pull the mains plug.**

### Mounting the Grinding Tools (see figure A)

- ▶ **Only use properly fitting and undamaged open-end spanners (see "Technical Data").**
- Clean the grinder spindle **3** and all parts to be mounted.
- Hold the grinder spindle **3** with open-end spanner **8** by the spanner flats.  
Loosen the clamping nut **2** with open-end spanner **9** by applying it to the spanner flats and turning in anticlockwise direction.
- Insert the clamping shaft of the grinding tool to the stop into the collet chuck **1**.
- Hold the grinder spindle **3** firmly with open-end spanner **8** and clamp the tool bit with open-end spanner **9** by the spanner flats, turning in clockwise direction.

The grinding tools must run completely concentric. Do not continue to use out-of-round grinding accessories, instead, replace before continuing to work.

- ▶ **Do not tighten the collet chuck of the clamping nut as long as no grinding accessory is mounted.** Otherwise, the collet chuck can become damaged.

### Dust/Chip Extraction

- ▶ Dusts from materials such as lead-containing coatings, some wood types, minerals and metal can be harmful to one's health. Touching or breathing-in the dusts can cause allergic reactions and/or lead to respiratory infections of the user or bystanders.  
Certain dusts, such as oak or beech dust, are considered as carcinogenic, especially in connection with wood-treatment additives (chromate, wood preservative). Materials containing asbestos may only be worked by specialists.

- Provide for good ventilation of the working place.
  - It is recommended to wear a P2 filter-class respirator.
- Observe the relevant regulations in your country for the materials to be worked.

- ▶ **Prevent dust accumulation at the workplace.** Dusts can easily ignite.

## Operation

### Starting Operation

- ▶ **Observe correct mains voltage! The voltage of the power source must agree with the voltage specified on the nameplate of the machine. Power tools marked with 230 V can also be operated with 220 V.**

### Switching On and Off

To **start** the power tool, push the On/Off switch **5** forwards.  
To **lock** the On/Off switch **5**, press the On/Off switch **5** down at the front until it latches.

To **switch off** the power tool, release the On/Off switch **5** or, if it is locked, briefly push down the back of the On/Off switch **5** and then release it.

### Kickback stop

In case of a sudden drop in speed, e.g., caused by a jammed disc while cutting, the power supply to the motor is electronically interrupted.

To **restart the operation**, switch the On/Off switch **5** to the Off position and start the machine again.

### Constant Electronic Control

Constant electronic control holds the speed constant at no-load and under load, and ensures uniform working performance.

### Speed preselection

The required speed can be preselected with the thumbwheel **6** (also while running).

The required speed depends on the material being worked and the diameter of the application tool. Observe the maximal allowable speed of the application tool.

Thumbwheel Position	No-load speed (min <sup>-1</sup> )
1	10000
2	12700
3	16700
4	19700
5	23500
6	28000

### Working Advice

Optimum grinding results are achieved when the grinding tool is moved uniformly back and forth with light pressure. Pressure that is too strong reduces the performance capability of the machine and causes the grinding tool to wear more quickly.

## Maintenance and Service

### Maintenance and Cleaning

- ▶ **Before any work on the machine itself, pull the mains plug.**
- ▶ **For safe and proper working, always keep the machine and ventilation slots clean.**
- ▶ **In extreme conditions, always use dust extraction as far as possible. Blow out ventilation slots frequently and install a residual current device (RCD).** When working metals, conductive dust can settle in the interior of the power tool. The total insulation of the power tool can be impaired.

Please store and handle the accessory(-ies) carefully.

If the machine should fail despite the care taken in manufacturing and testing procedures, repair should be carried out by an after-sales service centre for Bosch power tools.

In all correspondence and spare parts order, please always include the 10-digit article number given on the type plate of the machine.

### After-sales Service and Application Service

Our after-sales service responds to your questions concerning maintenance and repair of your product as well as spare parts. Exploded views and information on spare parts can also be found under:

**www.bosch-pt.com**

Bosch's application service team will gladly answer questions concerning our products and their accessories.

### People's Republic of China

#### China Mainland

Bosch Power Tools (China) Co., Ltd.  
567, Bin Kang Road  
Bin Jiang District 310052  
Hangzhou, P. R. China  
Service Hotline: 4008268484  
Fax: (0571) 87774502  
E-Mail: contact.ptcn@cn.bosch.com  
www.bosch-pt.com.cn

### HK and Macau Special Administrative Regions

Robert Bosch Hong Kong Co. Ltd.  
21st Floor, 625 King's Road  
North Point, Hong Kong  
Customer Service Hotline: +852 2101 0235  
Fax: +852 2590 9762  
E-Mail: info@hk.bosch.com  
www.bosch-pt.com.hk

### Indonesia

PT. Multi Mayaka  
Kawasan Industri Pulogadung  
Jalan Rawa Gelam III No. 2  
Jakarta 13930  
Indonesia  
Tel.: (021) 46832522  
Fax: (021) 46828645/6823  
E-Mail: sales@multimayaka.co.id  
www.bosch-pt.co.id

### Philippines

Robert Bosch, Inc.  
28th Floor Fort Legend Towers,  
3rd Avenue corner 31st Street,  
Fort Bonifacio Global City,  
1634 Taguig City, Philippines  
Tel.: (02) 8703871  
Fax: (02) 8703870  
matheus.contiero@ph.bosch.com  
www.bosch-pt.com.ph

Bosch Service Center:  
9725-27 Kamagong Street  
San Antonio Village  
Makati City, Philippines  
Tel.: (02) 8999091  
Fax: (02) 8976432  
rosalie.dagdagan@ph.bosch.com

### Malaysia

Robert Bosch (S.E.A.) Sdn. Bhd.  
No. 8A, Jalan 13/6  
G.P.O. Box 10818  
46200 Petaling Jaya  
Selangor, Malaysia  
Tel.: (03) 79663194  
Fax: (03) 79583838  
cheehoe.on@my.bosch.com  
Toll-Free: 1800 880188  
www.bosch-pt.com.my

### Thailand

Robert Bosch Ltd.  
Liberty Square Building  
No. 287, 11 Floor  
Silom Road, Bangrak  
Bangkok 10500  
Tel.: 02 6311879 – 18 88 (10 lines)  
Fax: 02 2384783  
Robert Bosch Ltd., P. O. Box 2054  
Bangkok 10501, Thailand

Bosch Service – Training Centre  
2869-2869/1 Soi Ban Kluay  
Rama IV Road (near old Paknam Railway)  
Prakanong District  
10110 Bangkok  
Thailand  
Tel.: 02 67178 00 – 4  
Fax: 02 2494296  
Fax: 02 2495299



8 | English



**Singapore**

Robert Bosch (SEA) Pte. Ltd.  
11 Bishan Street 21  
Singapore 573943  
Tel.: 6571 2772  
Fax: 6350 5315  
leongheng.leow@sg.bosch.com  
Toll-Free: 1800 3338333  
www.bosch-pt.com.sg

**Vietnam**

Robert Bosch Vietnam Co. Ltd  
10/F, 194 Golden Building  
473 Dien Bien Phu Street  
Ward 25, Binh Thanh District  
84 Ho Chi Minh City  
Vietnam  
Tel.: (08) 6258 3690 ext. 413  
Fax: (08) 6258 3692  
hie.u.lagja@vn.bosch.com  
www.bosch-pt.com

**Australia, New Zealand and Pacific Islands**

Robert Bosch Australia Pty. Ltd.  
Power Tools  
Locked Bag 66  
Clayton South VIC 3169  
Customer Contact Center  
Inside Australia:  
Phone: (01300) 307044  
Fax: (01300) 307045  
Inside New Zealand:  
Phone: (0800) 543353  
Fax: (0800) 428570  
Outside AU and NZ:  
Phone: +61 3 95415555  
www.bosch.com.au

**Disposal**

The machine, accessories and packaging should be sorted for environmental-friendly recycling.

Do not dispose of power tools into household waste!

**Subject to change without notice.**

