

**Temperature maintenance
and frost protection systems**



Useful instructions for the use of this technical handbook

For your customers...



The “as installed” diagram of a system installation with all its components can be found in this handbook (see pages 4, 10, 17, etc.). They can easily be copied and either sent or faxed to your customers together with your quotation or other information.

For the worksite...

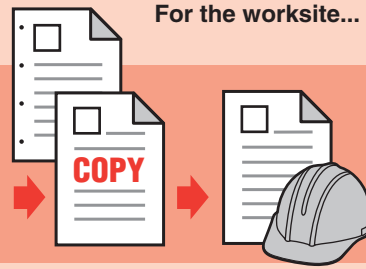

Practical information or handy tips for fast installation of the system components can be found in the section “General Installation Instructions” (see page 35).

Temperature maintenance and frost protection systems

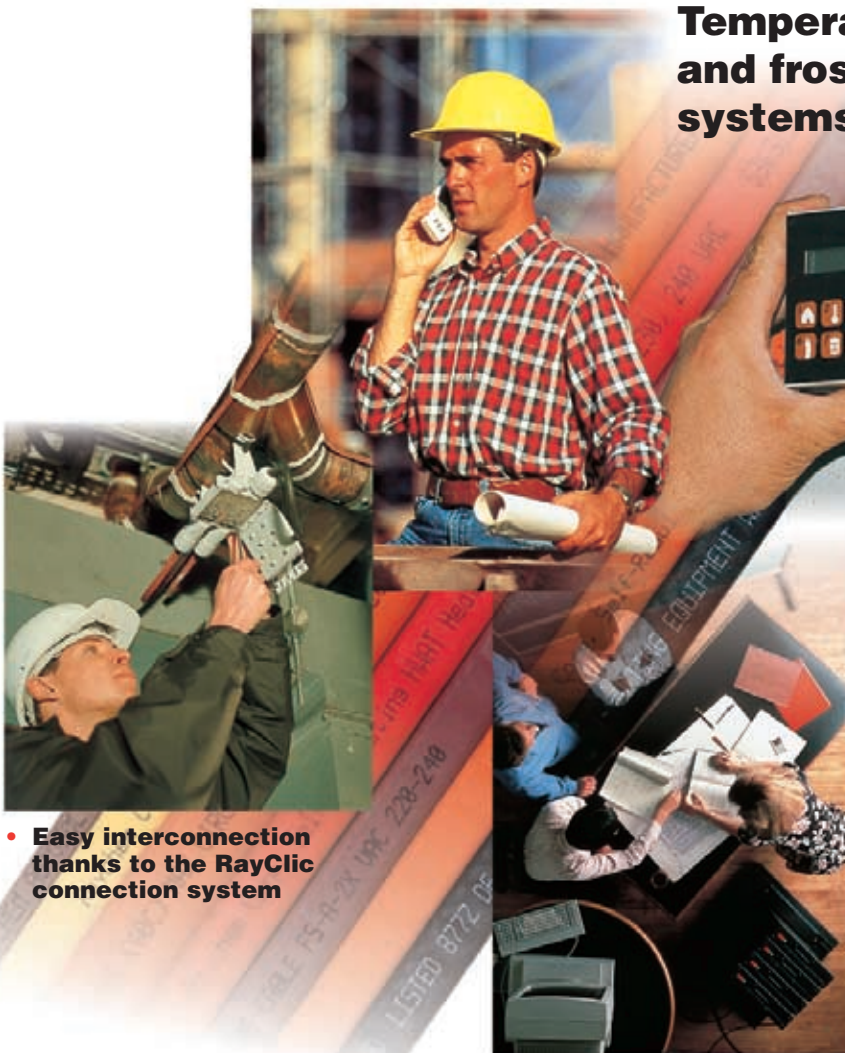

- **The correct accessories for each application**

- **Easy interconnection thanks to the RayClic connection system**

- **Easy design, specification and installation:**
 - one metre of pipe requires one metre of heating cable
 - specification texts are available separately

Raychem

Overview of applications

HWAT-Plus system

Hot water temperature maintenance

4

IceStop system

Maintaining water flow in gutters and down-pipes during winter

20

WinterCard system

Self-regulating frost protection system for pipes

10

AutoSol system

Self-regulating gentle underfloor heating

34

ViaGard system

Self-regulating heating system to keep ramps, steps and footpaths free from snow and ice

25

Installation instructions

General installation instructions for self-regulating trace heating systems

35

Other applications

FreezGard system
Self-regulating heating cables for the refrigeration industry

31

TraceTek system
Leak detection and location system

33

HWAT-Plus system



Hot water temperature maintenance

- High reliability: instant hot water from every tap
- No return pipes: reduced energy consumption and space-saving
- Maintenance-free: no circulation pump
- Easy and flexible design: no pressure loss calculations
- Easy assembly: RayClic connection system

Efficient energy use:

- HWAT-L: 7 W/m at 45°C
- HWAT-M: 9 W/m at 55°C
- HWAT-R: 12 W/m at 70°C

Further energy efficiency in combination with the HWAT-ECO control unit: 4-6 W/m (HWAT-R)

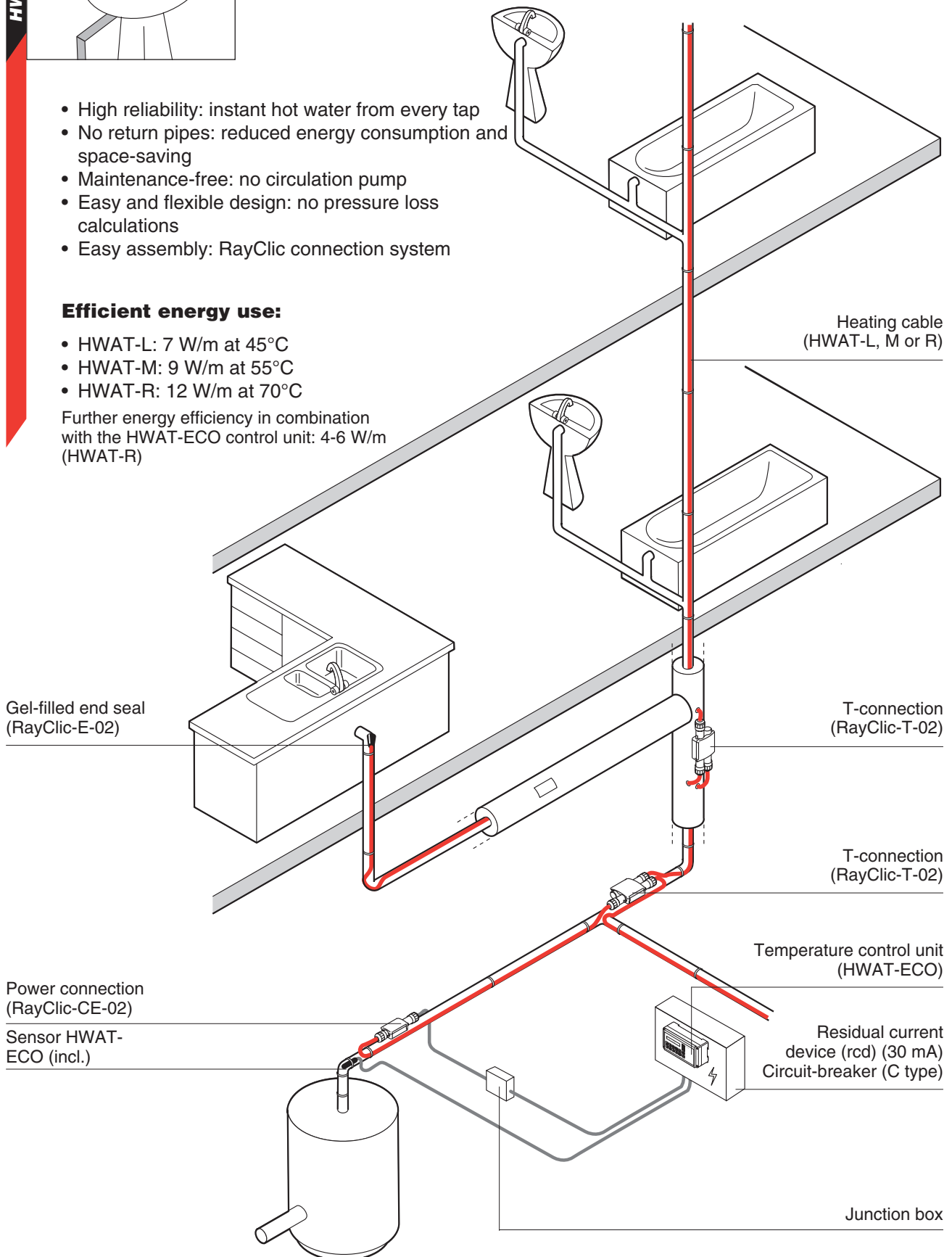

Design guide, control units and accessories

1. Application

Optimum water temperature maintenance for single family houses, flats, offices, hotels, hospitals, convalescent homes, sports centres, ...

Heating cable type	HWAT-L	HWAT-M	HWAT-R
Maintenance temperature	typically 45°C	typically 55°C	variable 50-70°C
Max. exposure temperature	65°C	65°C	85°C
Outer jacket colour	yellow	orange	red
Control unit HWAT-ECO	–	compatible	essential
Timer QWT-04	recommended	–	–
Thermal disinfection			Possibility of thermal legionella prevention up to the drawoff points

2. HWAT heating cable composition

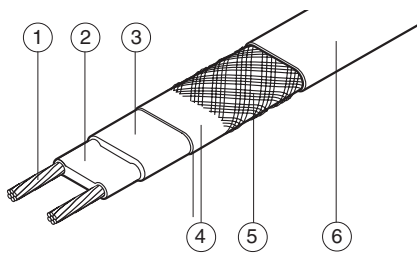

1. Copper conductor (1.2 mm²)
2. Self-regulating heat element
3. Insulation made of modified polyolefin
4. Aluminium laminated wrap
5. Protective tinned copper braid
6. Protective jacket made of modified polyolefin

Technical data: see page 57

3. HWAT heating cable length

- The heating cable is installed in a straight line on the pipework
- The heating cable can be traced right up to the drawoff points

Total length of pipe to be traced
 + approx. 0.3 m per connection
 + approx. 1.0 m per T-connection
 + approx. 1.2 m per 4-way connection
 = required heating cable length

4. Insulation thicknesses

Pipe size (mm)	15	22	28	35	42	54
Insulation thickness (mm)	20	20	25	30	40	50

Ambient temperature: 18°C
 Thermal conductivity $\lambda = 0.035 \text{ W/(m.K)}$
 For other thermal conductivity insulation materials, contact your Raychem representative.

5. Electrical protection

- The total length of heating cable determines the number and size of the circuit breakers
- Residual current device (rcd): 30 mA required
- Power line for the heating cables according to local regulations
- The power connection must be carried out by an approved electrical installer

Circuit-breaker to BSEN 60898 (type C): the maximum length of the heating circuit is based on a minimum start-up temperature of +12°C, 230 Vac.

	HWAT-L	HWAT-M	HWAT-R
10 A	80 m	50m	50 m
13 A	110 m	65 m	65 m
16 A	140 m	80 m	80 m
20 A	180 m	100 m	100 m

6. Control units

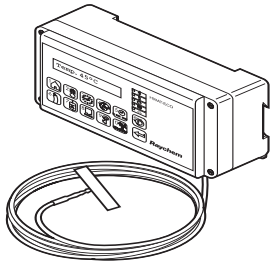

HWAT-ECO

- Electronic temperature control unit with integrated clock
- Nine building-specific-programmes
 - Boiler temperature monitoring
 - Holiday button
 - Password protection
 - Easy user interface
 - Compatible with all HWAT heating cables
 - BMS interface

Technical data: see page 9

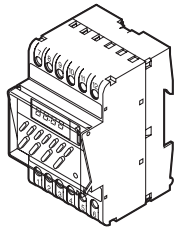

QWT-04

Pre-programmed, two-channel timer with 7-day programming.

Technical data: see page 8

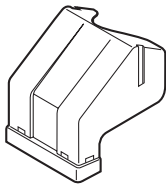

HARD-70

Terminal cover kit for QWT-04

7. Accessories

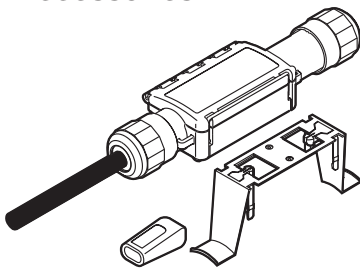

RayClic-CE-02

- Power connection with 1.5 m power cable
- End seal and support bracket
 - IP 68 weather protection

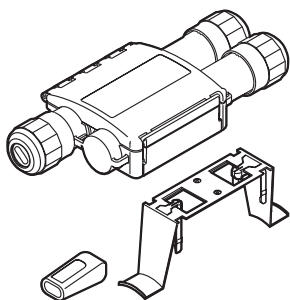
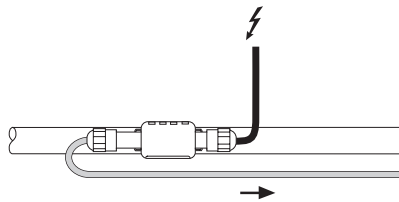

RayClic-T-02

- T-connection
- Connection for 3 cables
 - End seal and support bracket
 - IP 68 weather protection

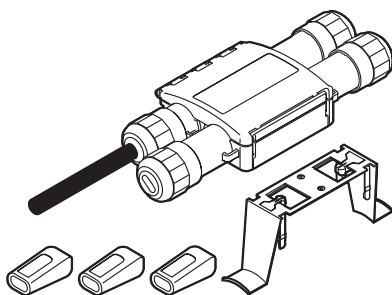
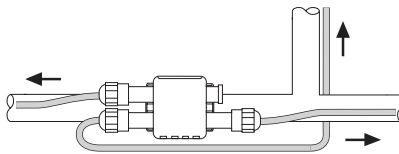

RayClic-PT-02

- Power T-connection
- 3 connections with integral 1.5 m power cable
 - 3 end seals and 1 support bracket
 - IP 68 weather protection

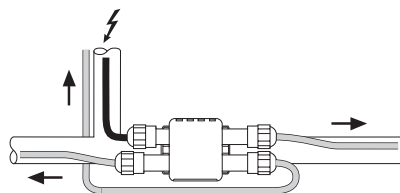

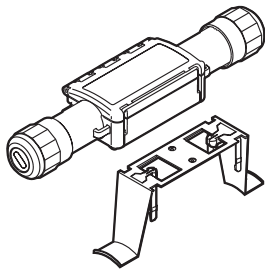

RayClic-S-02

Splice for joining 2 lengths of heating cable

- Connection for 2 cables with 1 support bracket
- IP 68 weather protection

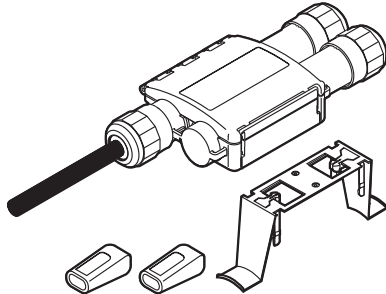
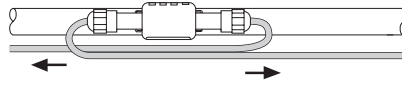

RayClic-PS-02

Powered splice

- Connection for 2 cables with integral 1.5 m power cable
- 2 end seals and 1 support bracket
- IP 68 weather protection

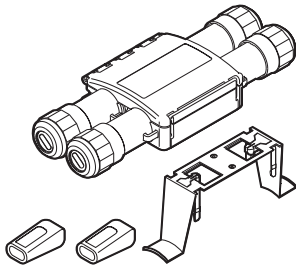
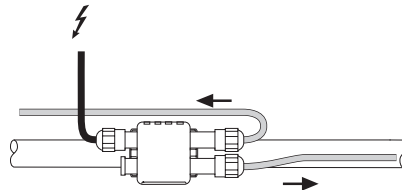

RayClic-X-02

4-way connection

- Connection for 4 cables
- 2 end seals and 1 support bracket
- IP 68 weather protection

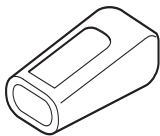
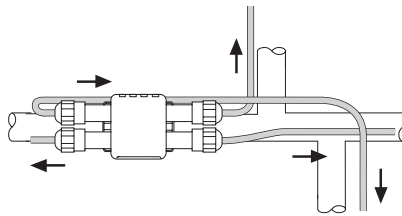

RayClic-E-02

Gel-filled end seal

- For system extensions (to be ordered separately)
- IP 68 weather protection

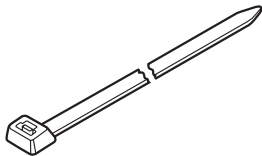

KBL-10

Cable ties

- One pack of 100 required for approx. 30 m of pipework
- Length: 370 mm
- Temperature and UV resistant

Use ATE-180 on plastic pipes



GT-66

Heat-resistant glass cloth tape

- Heat resistant up to 130°C
- 20 m roll for approx. 20 m of pipework

Use ATE-180 on plastic pipes

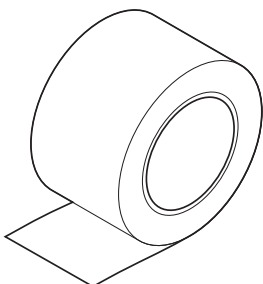

ATE-180

Aluminium adhesive tape

- Heat resistant up to 150°C
- 55 m roll for approx. 50 m of pipework

On plastic pipes: the heating cable must be covered with aluminium adhesive tape along its entire length.

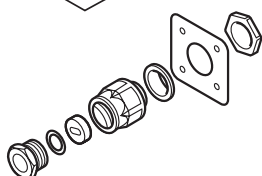

IEK-16-05

Insulation entry kit

- Insertion of heating cable in metal cladding
- Consists of: metal fasteners, PG 16 gland and joint seal



ETL

Electric traced label
 • To be placed at 5 m intervals on pipework surface

8. Supply voltage

The supply voltage lead to the heating circuits must be laid according to the local standards, codes and regulations.

MCBs to BS EN 60898 Type C or D, or equivalent	Min. power cable diameter (mm ²)	Max. power cable length (m) HWAT-M	HWAT-R
10 A	3 x 1.5	200	80
16 A	3 x 1.5	100	50
20 A	3 x 2.5	130	70

9. Technical data of control units

QWT-04 timer

Module layout

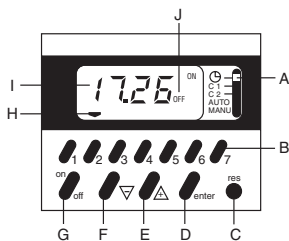

- A.** Selection of the modes (sliding switch)
 ☰ = Time setting
 C1 = Programming channel 1
 C2 = Programming channel 2
 AUTO = running mode
 MANU = permanent or timed manual overrides (1 hour to 27 days)
- B.** Day selection
- C.** Reset
- D.** Enter (confirm setting)
- E. F.** Scrolling hours and minutes
- G.** ON/OFF
- H.** Display of the days of the week
- I.** Time display
- J.** Status of channels 1 + 2
 Channel 1 left
 Channel 2 right

Technical data

Reference number	Timer	QWT-04
	Terminal cover kit	HARD-70
Operating voltage		110-240 Vac / +10% -15% / 50/60Hz
Programme		Day/week
Switching intervals		140 per week 20 set points to share between the two channels (one set point can be allocated to one or several days without using more capacity)
Minimum programming step		1 minute
Channels		2
Switch rating		1 potential-free selector per channel 16 A, 250 Vac
Battery back-up		> 3 years through lithium battery
Power consumption		< 1 VA
Accuracy		± 1 sec/day at 25°C
Operation and storage temperature		-10°C to +50°C
Material		ABS Cicolac and ABS PC Cicoloy
Ingress protection		IP 40
Weight		190 g
Mounting		Mounted on DIN rail
Terminals		Wire cross-section: 1 to 4 mm ²

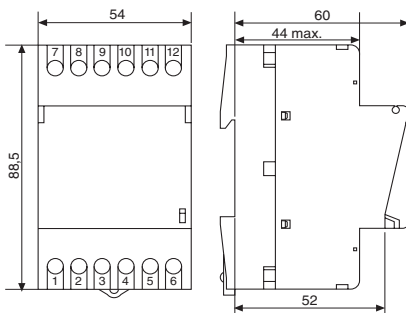

(Dimensions in mm)

HWAT-ECO Temperature control unit

Module layout

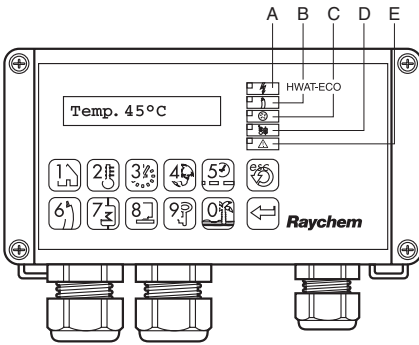

A	Unit power on (green LED)
B	Cable power on (green LED)
C	Thermal desinfection cycle (green LED) - heating cable 100% powered - increased risk of scalding
D	Maintain temperature lowered following boiler temperature decrease (green LED) - boiler temperature is lower than expected.
E	Error (red LED)
1	Selection of building specific pre-programmes
2	Maintain temperature setting
3	Time setting
4	Language selection
5	Edit / new timer programme
6	Heating cable selection (HWAT-R, HWAT-M, HWAT-L)
7	Setting of maintain temp. relative to boiler temp.
8	Master/slave and BMS functions
9	Lock/unlock (password)
0	Heating cable off (holiday)
Esc	Escape, backspace or NO
Enter	Confirm selection, new value or YES

Technical data

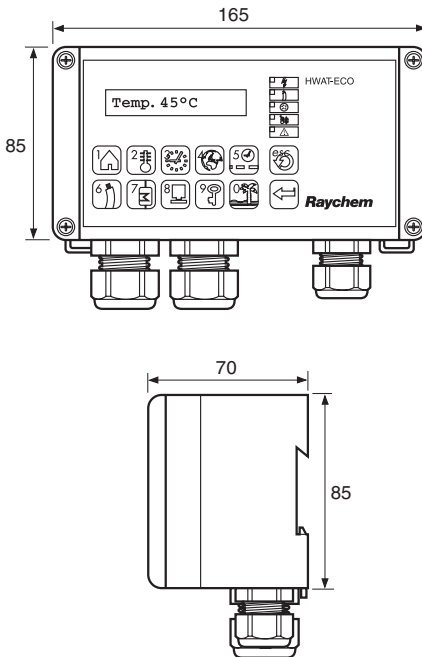

Product description	HWAT-ECO
Use	Only for HWAT heating cables
Selectable maintain temperature	35°C to 65°C in max. 10 timer blocs per day
Operating voltage	230 Vac (+10%, -10%), 50 Hz
Switching capacity	20 A / 230 Vac
Off-power	2,5 W
Circuit breaker	Max. 20 A, C-Characteristic
Power cable section entry	1.5 - 4 mm ² for fixed wiring only
Auxiliary cable section entry	Up to 16 AWG (1,3 mm ²)
Weight	880 g
Mounting options	Wall mount with 2 screws or DIN rail
Cable glands (entries)	2 x M20 and 1 x PG13.5 with 3 inputs for external wires of 3-5 mm
Protection level	IP 54
Ambient temperature	0°C to 40°C
Housing material	ABS
Internal temperature alarm	85°C
Master/slave cable	2-wire twisted pair, max. 1,3 mm ² core and insulation of 500 V
Master/slave	Master is selectable in the unit, up to 8 slaves can be connected
BMS interface	1 - 10 VDC
Boiler temperature sensor	NTC
Clock back-up time	8 hours ±10%
Clock accuracy	20 ppm, ±10 minutes per year
Approval	VDE according to EN 60730
EMC	According to EN 50081-1/2 for emission and EN 50082-1/2 for immunity

Programme

9 Editable building-specific pre-programmes	
4 Programme types	<ul style="list-style-type: none"> - 7 Days different - All days the same - Week - weekend - Monday to Saturday - Sunday
Real time clock	Automatic summer/winter time and leap year correction

Raychem requires the use of a 30 mA residual current device and a C-Characteristic circuit breaker to provide maximum safety and protection from fire.

The unit complies with IEC1000-3-3 (flicker) if installed according to part 3 of VDE 0838. To avoid flicker install the unit in such a way that at the current value of the systems start-up temperature (max. 20 A per heating circuit) the voltage drop does not exceed 1% at the power supply of the lightning apparatus (normally subpanel).

WinterGard system



Self-regulating frost protection system for pipes

- Reliability: protects your pipes from frost damage
- Maintenance-free

Efficient energy use

- FS-A-2X: 10 W/m at 5°C
- FS-B-2X: 26 W/m at 5°C
- FS-C-2X: 31 W/m at 5°C
22 W/m at 40°C

End seal
(RayClic-E-02
not for FS-C-2X)

Thermostat with line or
ambient temperature
sensor

Residual current
device (30 mA)
Circuit-breaker
(C type)

Junction box
(JB16-02)

Electrical traced
label (ETL)

Power connection
(RayClic-CE-02)
Not for FS-C-2X

T-Connection
(RayClic-T-02)
Not for FS-C-2X

Frost protection heating
cable (FS-A-2X, FS-B-2X
or FS-C-2X)

Design guide, control units and accessories

1. Cable selection

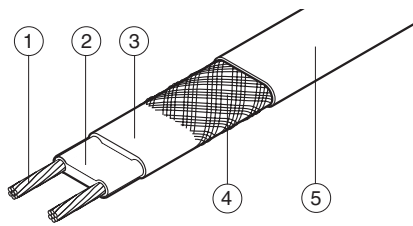

Composition

1. Copper conductor (1,2 m²)
2. Self-regulating heat element
3. Insulation made of modified polyolefin (FS-C-2X: Fluoropolymer)
4. Protective tinned copper braid
5. Protective jacket made of modified polyolefin

Application

Frost protection for pipework at max. 65°C operating temperature

FS-A-2X	10 W/m at 5°C
FS-B-2X	26 W/m at 5°C

Frost protection for pipework at max. 95°C operating temperature and temperature maintenance for metal waste pipes with fatty waste water

FS-C-2X	31 W/m at 5°C
	22 W/m at 40°C

Insulation selection

Frost protection up to -20°C.

Insulation thicknesses	Pipe diameter													
	mm	15	22	28	35	42	54	67	76	108	125	150	200	
	Inches	1/2"	3/4"	1"	5/4"	1 1/2"	2"	2 1/2"	3"	4"	5"	6"	8"	
10 mm		FS-A-2X	FS-B-2X	FS-B-2X	FS-B-2X	FS-B-2X	FS-B-2X	FS-B-2X	FS-B-2X					
15 mm		FS-A-2X	FS-A-2X	FS-A-2X	FS-B-2X	FS-B-2X	FS-B-2X	FS-B-2X	FS-B-2X	FS-B-2X	FS-B-2X			
20 mm		FS-A-2X	FS-A-2X	FS-A-2X	FS-A-2X	FS-A-2X	FS-B-2X	FS-B-2X	FS-B-2X	FS-B-2X	FS-B-2X	FS-B-2X		
25 mm		FS-A-2X	FS-A-2X	FS-A-2X	FS-A-2X	FS-A-2X	FS-A-2X	FS-B-2X	FS-B-2X	FS-B-2X	FS-B-2X	FS-B-2X	FS-B-2X	
30 mm		FS-A-2X	FS-A-2X	FS-A-2X	FS-A-2X	FS-A-2X	FS-A-2X	FS-A-2X	FS-B-2X	FS-B-2X	FS-B-2X	FS-B-2X	FS-B-2X	FS-B-2X
40 mm		FS-A-2X	FS-A-2X	FS-A-2X	FS-A-2X	FS-A-2X	FS-A-2X	FS-A-2X	FS-A-2X	FS-B-2X	FS-B-2X	FS-B-2X	FS-B-2X	FS-B-2X
50 mm		FS-A-2X	FS-A-2X	FS-A-2X	FS-A-2X	FS-A-2X	FS-A-2X	FS-A-2X	FS-A-2X	FS-A-2X	FS-B-2X	FS-B-2X	FS-B-2X	FS-B-2X

Frost protection cables FS-A-2X and FS-B-2X are suitable for any pipe material (copper, threaded pipes, stainless steel pipes, plastic pipes and composite metal pipes without restriction).

For plastic pipes, please use aluminium adhesive tape ATE-180. The frost protection cable should be covered along its entire length. Heat insulation $\lambda = 0.035 \text{ W/(m.K)}$ or better.

Important note: frost protection heating cables with fluoropolymer protective jacket (e.g. type BTV2-CT) must be used for solvent-containing, mixed and/or bitumen-coated heat insulation.

40°C temperature maintenance on pipelines for fatty waste water

Insulation thicknesses	Pipe diameter (mm)							
	42	54	67	76	108	125	150	200
	1 1/2"	2"	2 1/2"	3"	4"	5"	6"	8"
30 mm	FS-C-2X							
40 mm	FS-C-2X	FS-C-2X	FS-C-2X					
50 mm	FS-C-2X	FS-C-2X	FS-C-2X	FS-C-2X				
60 mm	FS-C-2X	FS-C-2X	FS-C-2X	FS-C-2X	FS-C-2X	FS-C-2X	FS-C-2X	FS-C-2X

Min. ambient temperature -10°C . Heat insulation $\lambda = 0.035 \text{ W/(m.K)}$ or better.

Cable type FS-C-2X should only be used for pipework with a minimum continuous temperature resistance of 90°C. A line-sensing control thermostat (type AT-TS-14) must be used on plastic pipework (setting approx. 40°C).

2. Cable length

The heating cable should be installed in a straight line on the pipework. Cable loops instead of T-connections can be made on short stubs (up to approx. 3 m)

Total length of pipe to be traced
+ approx. 0.3 m per connection
+ approx. 1.0 m per T-connection
+ approx. 1.2 m per 4-way connection
Additional amount required for increased heat sinks at valves from 2" and for uninsulated pipe supports (approx. 1 m)
= required heating cable length

3. Electrical protection

- The total length of heating cable determines the number and size of the fuses
- Residual current device (rcd): 30 mA required, max. 500 m heating cable per rcd.
- Installation according to local regulations
- The power connections must be carried out by an approved electrical installer
- Use C type circuit-breakers

Max. length of the heating circuit is based on a minimum switch-on temperature of 0°C, 230 Vac.

	FS-A-2X	FS-B-2X	FS-C-2X
4 A	45 m	25 m	20 m
6 A	70 m	35 m	30 m
10 A	110 m	65 m	55 m
13 A	130 m	85 m	70 m
16 A	150 m	105 m	90 m

4. Thermostats

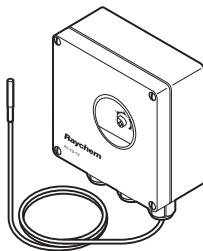

AT-TS-13

Thermostat

- Adjustable temperature range: -5°C to +15°C
- Line-sensing control thermostat or ambient thermostat
- Max. switching current 16 A 250 Vac

Technical data: see page 17

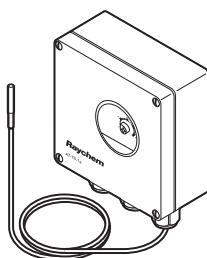

AT-TS-14

Thermostat

- Adjustable temperature range: 0°C to 120°C
- Temperature maintenance on pipelines for fatty waste water
- Line-sensing control thermostat
- Max. switching current 16 A 250 Vac

Technical data: see page 17

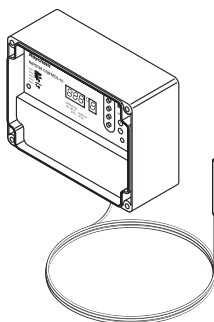

RAYSTAT-CONTROL-10

Line-sensing thermostat

- Adjustable temperature range: 0°C to 150°C
- Max. switching current 25 A 250 Vac
- Alarm relay: 2 A voltage free
- Indication of sensor errors, voltage errors and low or high temperature alarm
- Display for visual indication of parameters

Technical data: see page 18

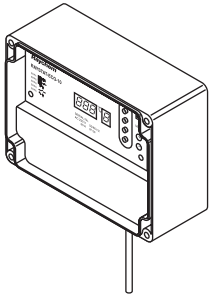

RAYSTAT-ECO-10

- Ambient temperature thermostat
- Adjustable temperature range: 0°C to 30°C
 - Max. switching current 25 A, 250 Vac
 - PASC (Proportional Ambient Sensing Control) for energy saving
 - Alarm relay: 2 A voltfree with indication of sensor errors, voltage errors and low or high temperature alarm
 - Display for visual indication of parameters

Technical data: see page 19

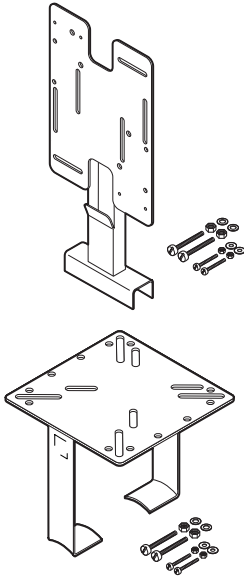

SB-100

Stainless steel support bracket specially constructed to provide heating cable protection between pipe and junction box via a tubular leg. For use with AT-TS-13, AT-TS-14, JB16-02 and RAYSTAT-CONTROL-10

SB-101

Dual-leg support bracket, stainless steel, height: 160 mm. For use with AT-TS-13, AT-TS-14, JB16-02 and RAYSTAT-CONTROL-10

5. Accessories for FS-A-2X and FS-B-2X cables

	FS-A-2X FS-B-2X
Power connection	RayClic-CE-02
Splice	RayClic-S-02
Powered splice	RayClic-PS-02
T-connection	RayClic-T-02
Powered T-connection	RayClic-PT-02
Four way connection	RayClic-X-02

Note: A splice can also be made using one S-06.

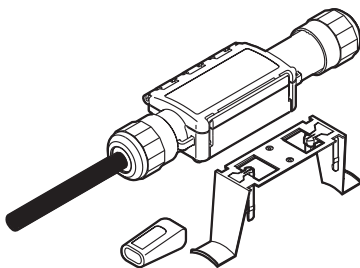

RayClic-CE-02

- Power connection with 1.5 m power cable
- End seal and support bracket
 - IP 68 weather protection

Cannot be used with FS-C-2X cables

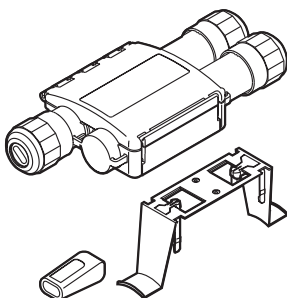
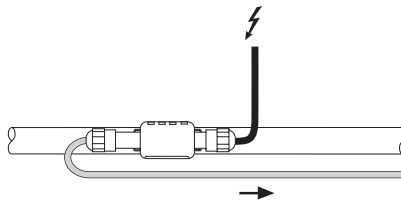

RayClic-T-02

- T-connection
- Connection for 3 cables
 - End seal and support bracket
 - IP 68 weather protection

Cannot be used with FS-C-2X cables

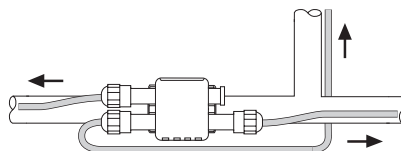

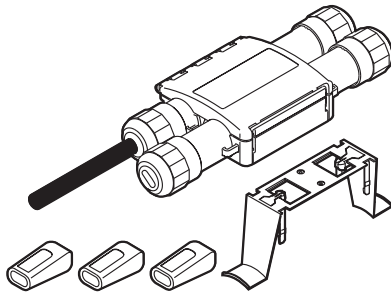

RayClic-PT-02

- Power T-connection
- 3 connections with integral 1.5 m power cable
 - 3 end seals and 1 support bracket
 - IP 68 weather protection

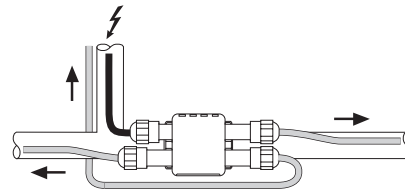

Cannot be used with FS-C-2X cables

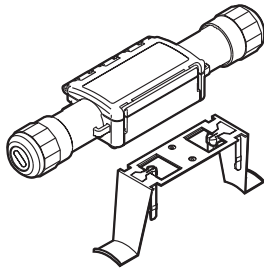

RayClic-S-02

- Splice for joining 2 lengths of heating cable
- Connection for 2 cables with 1 support bracket
 - IP 68 weather protection

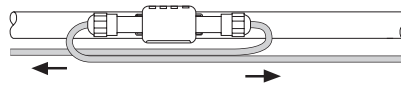

Cannot be used with FS-C-2X cables

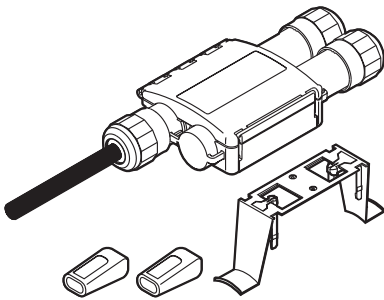

RayClic-PS-02

- Powered splice
- Connection for 2 cables with integral 1.5 m power cable
 - 2 end seals and 1 support bracket
 - IP 68 weather protection

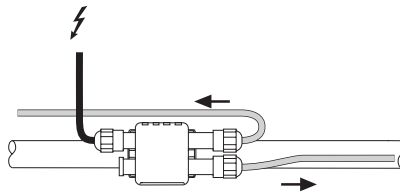

Cannot be used with FS-C-2X cables

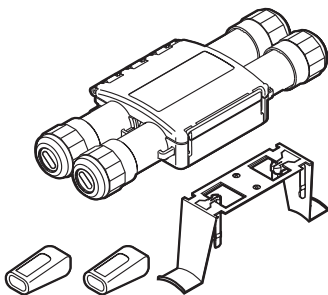

RayClic-X-02

- 4-way connection
- Connection for 4 cables
 - 2 end seals and 1 support bracket
 - IP 68 weather protection

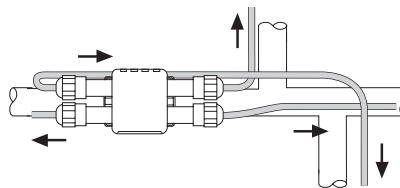

Cannot be used with FS-C-2X cables

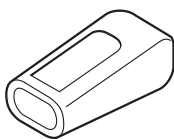

RayClic-E-02

- Gel-filled end seal
- For system extensions (to be ordered separately)
 - IP 68 weather protection



Cannot be used with FS-C-2X cables

6. Accessories for FS-C-2X and BTV-2-CT cables

		For BTV-2-CT	For FS-C-2X
Power connection	1 JB16-02 +	1 C16-29 + 1 E-06	+ 1 CE 20-01 + 1 JB-SB-08
Splice	1 JB16-02 +	2 C16-29 + 1 E-06	+ 2 CE 20-01 + 1 JB-SB-08
Powered splice	1 JB16-02 +	2 C16-29 + 2 E-06	+ 2 CE 20-01 + 1 JB-SB-08
T-connection	1 JB16-02 +	3 C16-29 + 2 E-06	+ 3 CE 20-01 + 1 JB-SB-08
Powered T-connection	1 JB16-02 +	3 C16-29 + 3 E-06	+ 3 CE 20-01 + 1 JB-SB-08
Four way connection	1 JB16-02 +	4 C16-29 + 3 E-06	+ 4 CE 20-01 + 1 JB-SB-08

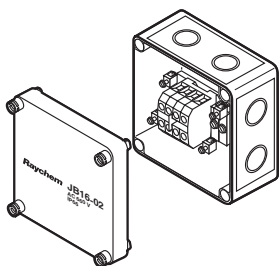

JB16-02

Temperature-resistant junction box

- For FS-C-2X and BTV-CT
- For power connection or T-connection

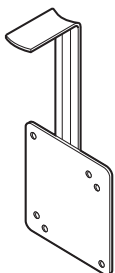

JB-SB-08

Single-leg support bracket (VA) for junction and connection box JB16-02

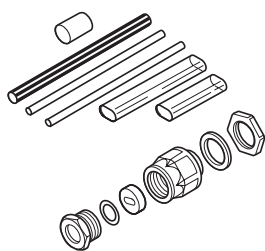

CE20-01

Connection and end seal kit for FS-C-2X cables

- Heat-shrink technique
- PG 16 glands

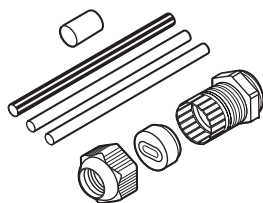

C16-29

Connection kit for BTV2-CT

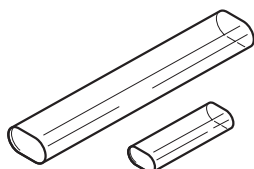

E-06

End seal kit for BTV2-CT

7. General accessories

S-06

In-line splice kit for FS-A-2X, FS-B-2X and FS-C-2X

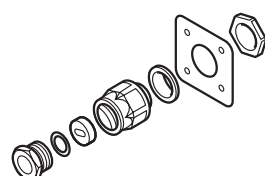
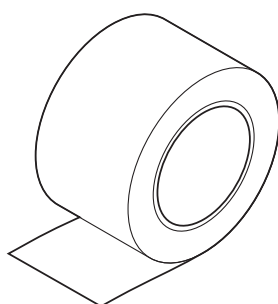
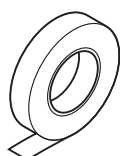
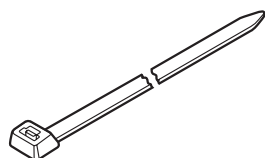
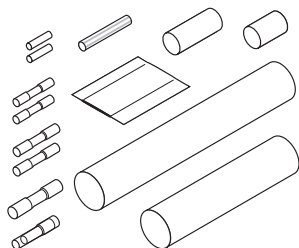
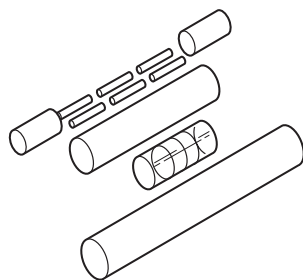

**ELECTRIC
TRACED**

Raychem

CCE-03-CR

Cold lead connection and end seal kit

- Connection of 3 x 1.5 mm² or 3 x 2.5 mm² cold lead cable to self-regulating heating cables WinterGard FS-A, FS-B, HWAT, IceStop GM-2X and FreezGard

KBL-10

Cable ties

- One pack of 100 required for approx. 30 m of pipework
- Length: 370 mm
- Temperature and UV resistant

On plastic pipes use ATE-180 tape

GT-66

Heat-resistant glass cloth tape

- Heat resistant up to 130°C
- 20 m roll for approx. 20 m of pipework

On plastic pipes use ATE-180 tape

ATE-180

Aluminium adhesive tape

- Heat resistant
- 55 m roll for approx. 50 m of pipework

On plastic pipes: the heating cable must be covered with aluminium adhesive tape along its entire length

IEK-16-05

Insulation entry kit

- Insertion of heating cable in metal cladding
- Consists of: metal fastener, Pg 16 gland and joint seal

ETL

Electric traced label

- To be placed at 5 m intervals on pipework surface

8. Technical data of control units

Line-sensing control and ambient thermostats (AT-TS-13 and AT-TS-14)

Unit layout

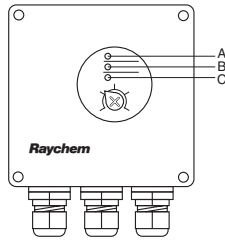

A	Green LED	Heating cable on
B	Red LED	Sensor break
C	Red LED	Sensor short-circuit

Technical data

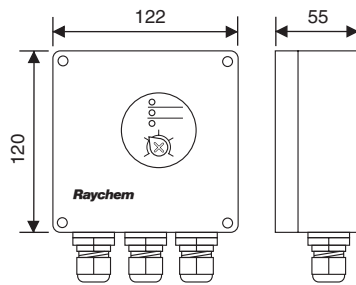

(Dimensions in mm)

Supply voltage	230 VAC +10% -15% 50/60 Hz	
Approval	CE	
Max. switching current	16 A, 250 Vac	
Max. conductor size	2.5 mm ²	
Switching differential	0.6 to 1 K	
Switching accuracy	AT-TS-13	± 1 K at 5°C (calibration point)
	AT-TS-14	± 2 K at 60°C (calibration point)
Switch type	SPST (normally open)	
Adjustable temperature range	AT-TS-13	-5°C to +15°C
	AT-TS-14	0°C to +120°C

Housing

Temperature setting	inside
Exposure temperature	-20°C to +50°C
Ingress protection	IP65 according to EN 60529
Entries	2 x Pg 16 for supply cable and for the connection to the heating cable 1 x Pg 11
Weight (without sensor)	approx. 440 g
Material	ABS
Lid fixing	nickel-plated quick release screws
Mounting	Raychem support bracket or wall mounting

Temperature sensor (HARD-69)

Type	PTC KTY 83-110
Length sensor cable	3 m
Diameter sensor cable	5.5 mm
Diameter sensor head	6.5 mm
Max. exposure temperature sensor cable	160°C

The sensor cable may be extended up to 100 m using a cable with a cross-section of 1.5 mm².

The sensor cable should be shielded if it is laid in cable ducts or in the vicinity of high-voltage cables.

Line-sensing thermostat with alarm relay RAYSTAT-CONTROL-10

Unit layout

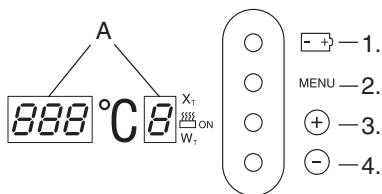

A. LED Display (parameter and error indications)

1. Battery activation
2. Parameter menu selection
3. Increase value
4. Decrease value

Technical data

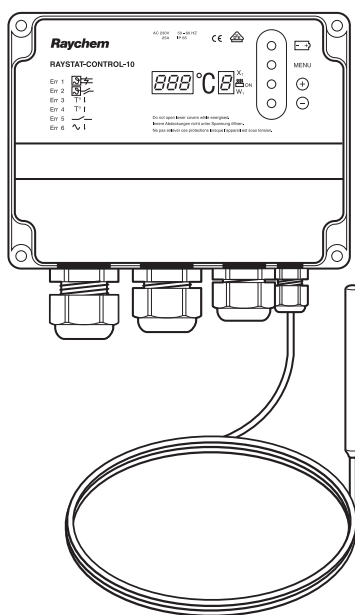

Operating Voltage	230 Vac., +10%/–10%, 50/60 Hz
Power Consumption	≤ 14 VA
Main Relay (heating)	I _{max} 25 A, 250 Vac., SPST
Main Terminals	3 x 0,75 mm ² to 4 mm ²
Alarm Relay	I _{max} 2 A, 250 Vac., SPDT, voltfree
Alarm Terminals	(3 + ±) x 0,75 mm ² to 2,5 mm ²
Accuracy	±0,5 K at 5°C
Ambient temperature	–40°C to +40°C

Parameter settings

Temperature Setting	0°C to +150°C
Hysteresis	1 K to 5 K
Low Temperature Alarm	–40°C to +148°C
High Temperature Alarm	+2°C to +150°C or switched OFF
Heater Operation if Sensor Error	ON or OFF
Voltage Free Operation	YES or NO

Diagnosed errors

Sensor Errors	Sensor short / Sensor open circuit
Temperature Extremes	High temperature / Low temperature
Voltage Errors	Low supply voltage / Output fault

Parameters can be programmed without power supply and parameters are stored in non-volatile memory.

Housing

Size	120 mm x 160 mm x 90 mm
Material	Grey polycarbonate
Ingress Protection	IP 65
Entries	2 x M25, 1 x M20, 1 x M16
Weight	Approx. 800 g
Lid	Transparent with 4 captive screws
Mounting	On wall or on support bracket SB-100/ SB-101

Temperature sensor

Sensor Type	3-wire Pt100 according to IEC Class B
Sensor Head	50 mm x Ø 6 mm
Sensor Cable Length	3 m x Ø 4 mm
Cable Exposure Temperature	–40°C to +150°C (+215°C, 1000 h max.)

Sensor cable can be extended up to 150 m when a cross-section of 3 x 1,5 mm² is used.

The sensor cable should be shielded if it is laid in cable ducts or in the vicinity of high-voltage cables.

Energy saving frost protection controller RAYSTAT-ECO-10

Unit layout

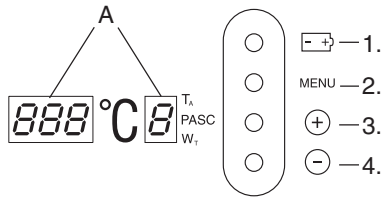

A. LED Display (parameter and error indications)

1. Battery activation
2. Parameter menu selection
3. Increase value
4. Decrease value

Technical data

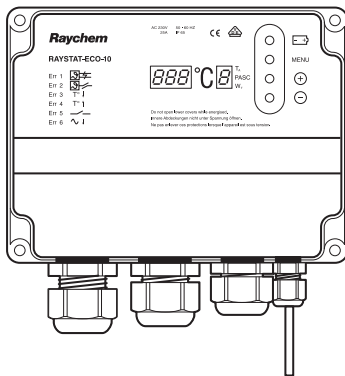

Operating Voltage 230 Vac., +10%/–10%, 50/60 Hz

Power Consumption ≤ 14 VA

Main Relay (heating) I_{max} 25 A, 250 Vac., SPST

Main Terminals 3 x 0,75 mm² to 4 mm²

Alarm Relay I_{max} 2 A, 250 Vac., SPDT, voltfree

Alarm Terminals (3 ± ½) x 0,75 mm² to 2,5 mm²

Accuracy ±0,5 K at 5°C

Main parameter settings

Energy Saving Algorithm Proportional Ambient Sensing Control (PASC) active below setpoint

Temperature Setpoint 0°C to +30°C
(switch off temperature)

Minimum Expected Ambient Temperature –40°C to –10°C
(heating 100% powered)

Heater Operation if Sensor Error ON (100%) or OFF

Voltage Free Operation YES or NO

Diagnosed alarms

Sensor Errors Sensor short / Sensor open circuit

Low Temperature Min. expected ambient temperature reached

Voltage Errors Low supply voltage / Output voltage fault

Parameters can be programmed without power supply and parameters are stored in non-volatile memory.

Housing

Size 120 mm x 160 mm x 90 mm

Material Grey polycarbonate

Exposure Temperature –40°C to +80°C

Ingress Protection IP 65

Entries 2 x M25, 1 x M20, 1 x M16

Weight Approx. 800 g

Lid Transparent with 4 captive screws

Mounting On wall or on support bracket SB-100/ SB-101

Temperature sensor

Sensor Type 3-wire Pt100 according to IEC Class B

Sensor Head Ø 6 mm

Sensor cable can be extended up to 150 m when a cross-section of 3 x 1,5 mm² is used.

The sensor cable should be shielded if it is laid in cable ducts or in the vicinity of high-voltage cables.

IceStop system

Self-regulating system to maintain water flow in gutters and downpipes during winter

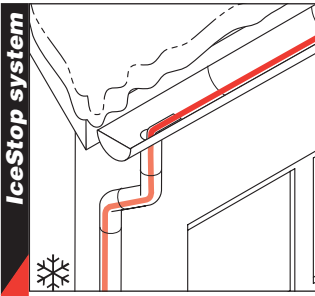

- Reliable protection against winter damage
- No danger of icicle formation or snow avalanches
- Protects buildings and persons
- Maintenance-free

Efficient energy use

- GM-2X: 36 W/m in iced water and 18 W/m in the air at 0°C

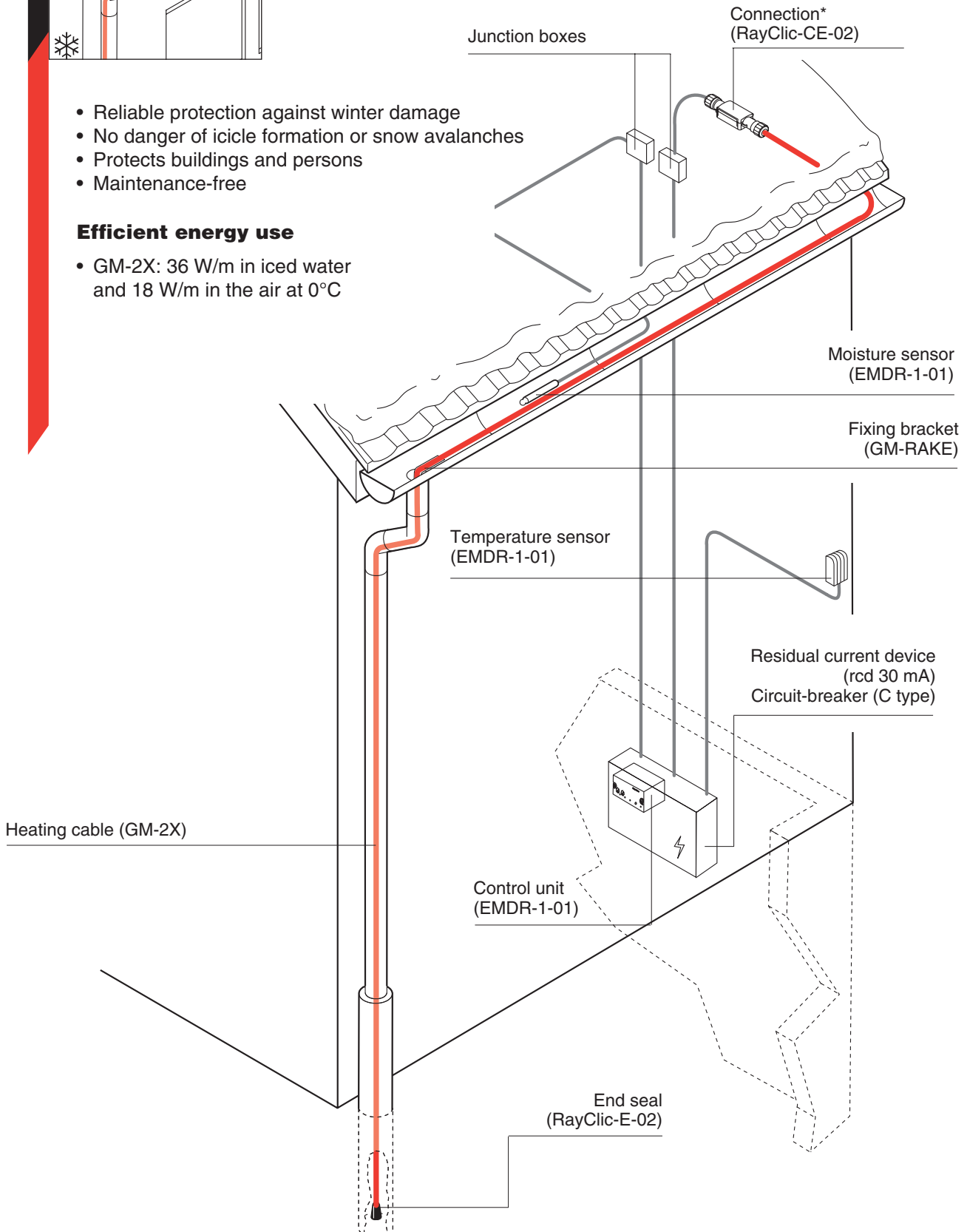

* Avoid installing RayClic on places where it is immersed in water.

Design guide, control units and accessories

1. Cable selection

GM-2X

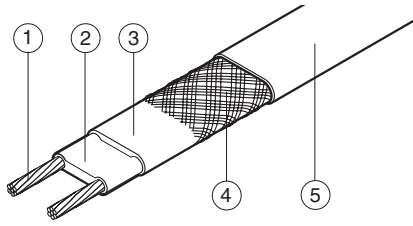

Self-regulating heating cable for:

- Gutters
- Downpipes
- Roof surfaces

Important note: When laying cables on asphalt, bitumen, roofing felt, etc., a cable with a special fluoropolymer jacket (8BTV- 2-CT) must be used.

Technical data: see page 57

Composition

1. Copper conductor (1.2 mm²)
2. Self-regulating heating element
3. Insulation made of modified polyolefin
4. Tinned copper braid
5. Protective jacket made of modified polyolefin (UV-resistant)

2. Cable length

- The heating cable should be installed in a straight line in the gutter.
- The cable lengths should be adjusted according to the geographical situation and the gutters
- More than one cable should be laid in wide valley, parapet or box gutters

Gutter length
 + drainpipe length
 + 1 m per connection
 + 1 m in the soil (frost line)

 = required heating cable length

3. Electrical protection

- The length of heating cable determines the number and size of the circuit breakers.
- Residual current device (rcd): 30 mA required, max. 500 m heating cable per rcd.
- Installation according to local regulations
- The power connections must be carried out by an approved electrical installer
- Use C type circuit-breakers

Max. length of the heating circuit is based on a minimum switch-on temperature of -10°C, 230 Vac.

	GM-2X	8BTV-2-CT
10 A	40 m	40 m
13 A	50 m	50 m
16 A	60 m	60 m
20 A	80 m	80 m

4. Control units

EMDR-1-01

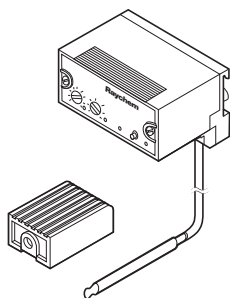

Control unit

- With temperature and moisture sensor
- Switch box installation
- User-friendly control
- Saves up to 80% power
- Max. switching capacity 6 A (otherwise switching by contactor)

Technical data: see page 24

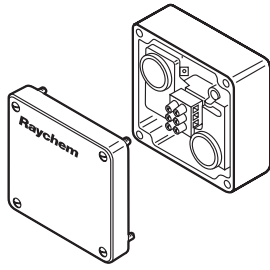

HTS-D

Thermostat

- 2 independant switching points
- max. switching current: 16 A - 250 Vac
- temperature adjustment range: -15°C to +15°C
- outdoor installation
- economical for circuit lengths up to 30 m

Technical data: see page 24

5. Accessories for IceStop GM-2X

Avoid installing RayClic on places where it is immersed in water.

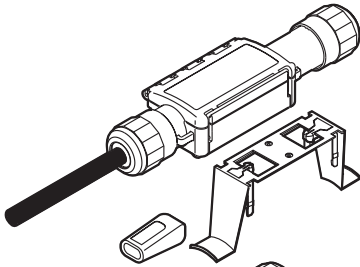

RayClic-CE-02

Power connection with 1.5 m power cable

- 1 end seal and 1 support bracket
- IP 68 weather protection

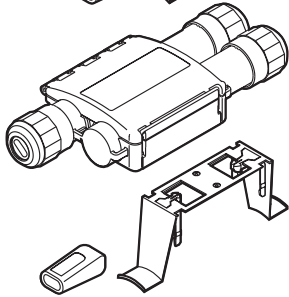
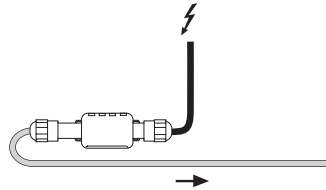

RayClic-T-02

T-connection

- Connection for 3 cables
- 1 end seal and 1 support bracket
- IP 68 weather protection

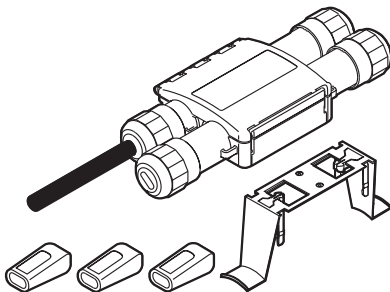
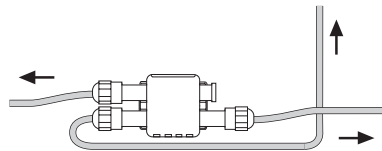

RayClic-PT-02

Power T-connection

- Connection for 3 cables with integral 1.5 m power cable
- 3 end seals and 1 support bracket
- IP 68 weather protection

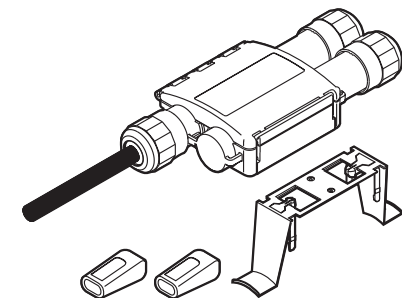
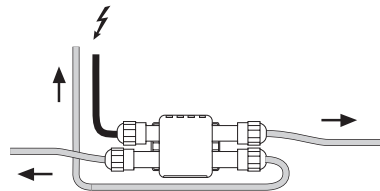

RayClic-PS-02

Powered splice

- Connection for 2 cables with integral 1.5 m power cable
- 2 end seals and 1 support bracket
- IP 68 weather protection

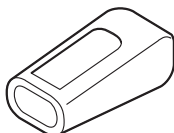
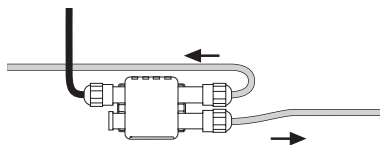

RayClic-E-02

Gel-filled end seal

- For system extensions (to be ordered separately)
- IP 68 weather protection

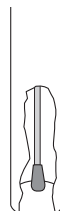

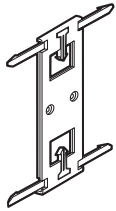

RayClic-SB-02

Wall-mounted support bracket

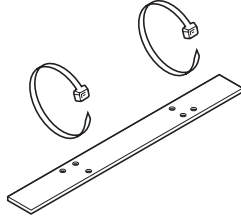

GM-RAKE

- Fixing bracket/edge protection for drainpipes
- Spacer for use in wide channels or gutters where more than one run of cable is required (a spacer is placed every 100 cm)
- VA steel with UV-resistant cable ties

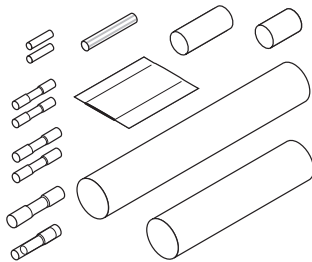

CCE-03-CR

- Cold lead connection and end seal kit
- Connection of 3 x 1.5 mm² or 3 x 2.5 mm² cold lead cable to self-regulating heating cables WinterGard FS-A, FS-B, HWAT and IceStop GM-2X

6. Accessories for 8BTV-2-CT heating cable

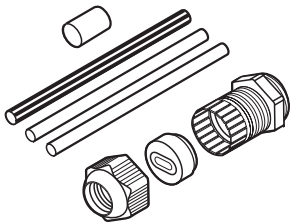

C16-29

Connection kit

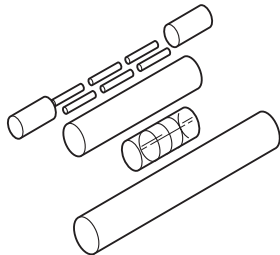

E-06

End Seal kit

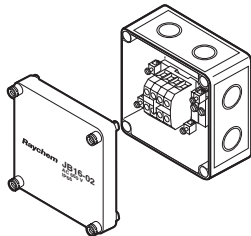

JB16-02

Junction box

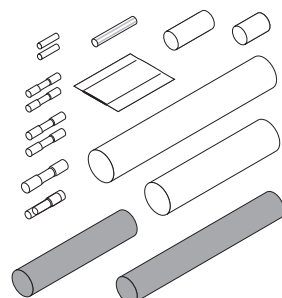

CCE-04-CT

- Cold lead connection and end seal kit
- Connection of 3 x 1.5 mm² or 3 x 2.5 mm² cold lead cable to self-regulating heating cables BTV-CT and WinterGard FS-C.

7. Technical data of control units

Temperature and moisture control EMDR-1-01

Technical data

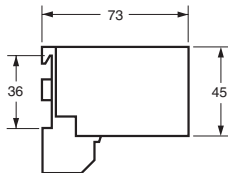
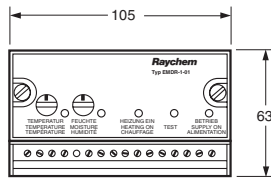

(Dimensions in mm)

Supply voltage	230 Vac +6% -10% 50 Hz
Power consumption (electronics)	max. 2 VA
Max. switching capacity	6 A (1 potential-free)
Temperature adjustment range	-3°C to +5°C (factory setting +2°C)
Lower limit temperature adjustment range	-25°C to -5°C (factory setting -25°C)
Switching hysteresis	± 0.5 K
Moisture adjustment range	1 to 7 (1 = min. sensitivity) (7 = max. sensitivity) factory setting 4.5
Min. heating time adjustment range	0 to 25 minutes (factory setting 25 minutes)
Measurement time delay after a power-on of the moisture sensor	8 minutes ± 1 minute

Housing

Ambient temperature range*	0°C to 40°C (device powered up to -25°C)
Ingress protection class	IP 20
Weight	approx. 360 g

* Continuous operation must be assured and the device must be protected from the penetration of moisture.

Temperature sensor (HARD-48)

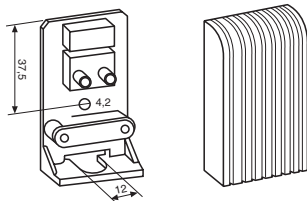

(Dimensions in mm)

Sensor characteristic	NTC
If necessary, the connection cable can be (max.) 100 m. Use a 2 x 1.5 mm cable with earth.	

The sensor cable may be extended up to 100 m using a cable with a cross-section of 1.5 mm². The sensor cable should be shielded if it is laid in cable ducts or in the vicinity of high-voltage cables.

Moisture sensor (HARD-45)

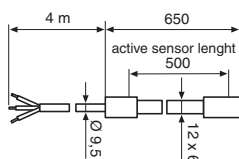

(Dimensions in mm)

Supply voltage	230 Vac +6% / -10% 50 Hz
Power consumption	9 to 18 W
Ambient temperature range	-30°C/+65°C continuous
Connection cable	3 x 1.5 mm ² with earth
Active sensor	length 500 mm

If necessary, the connection cable can be (max.) 100 m.

Thermostat HTS-D

Technical data

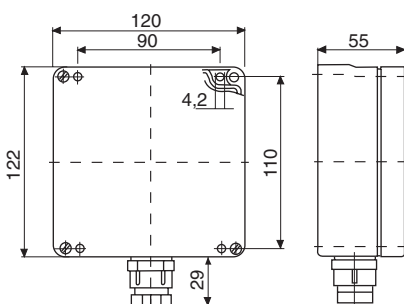

(Dimensions in mm)

Temperature adjustment range	-15°C to +15°C
Supply voltage	230 Vac 50 Hz
Contacts	potential-free
Ambient temperature	50°C
Switching hysteresis	1-3 K
Temperature setting	under housing cover
Ingress protection class	IP 65
Sensor	Bimetal

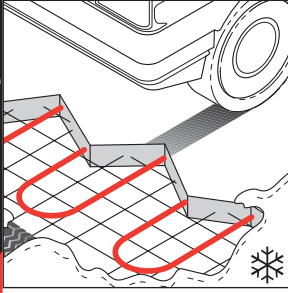

ViaGard system

Raychem

Self-regulating heating cable system to keep ramps, steps and footpaths free from snow and ice

- High reliability: ice and snow protection assures safer access
- Long service life
- Robust design

The energy-conscious solution

- EM2-XR: 300 W/m² (90 W/m) at 0°C
- VDE tested quality: the most stringent quality standards and constant internationally-recognized tests offer the highest level of safety

Temperature sensor (should be installed at a distance of 2,5 cm from the heating cable)
(VIA-DU-S4)

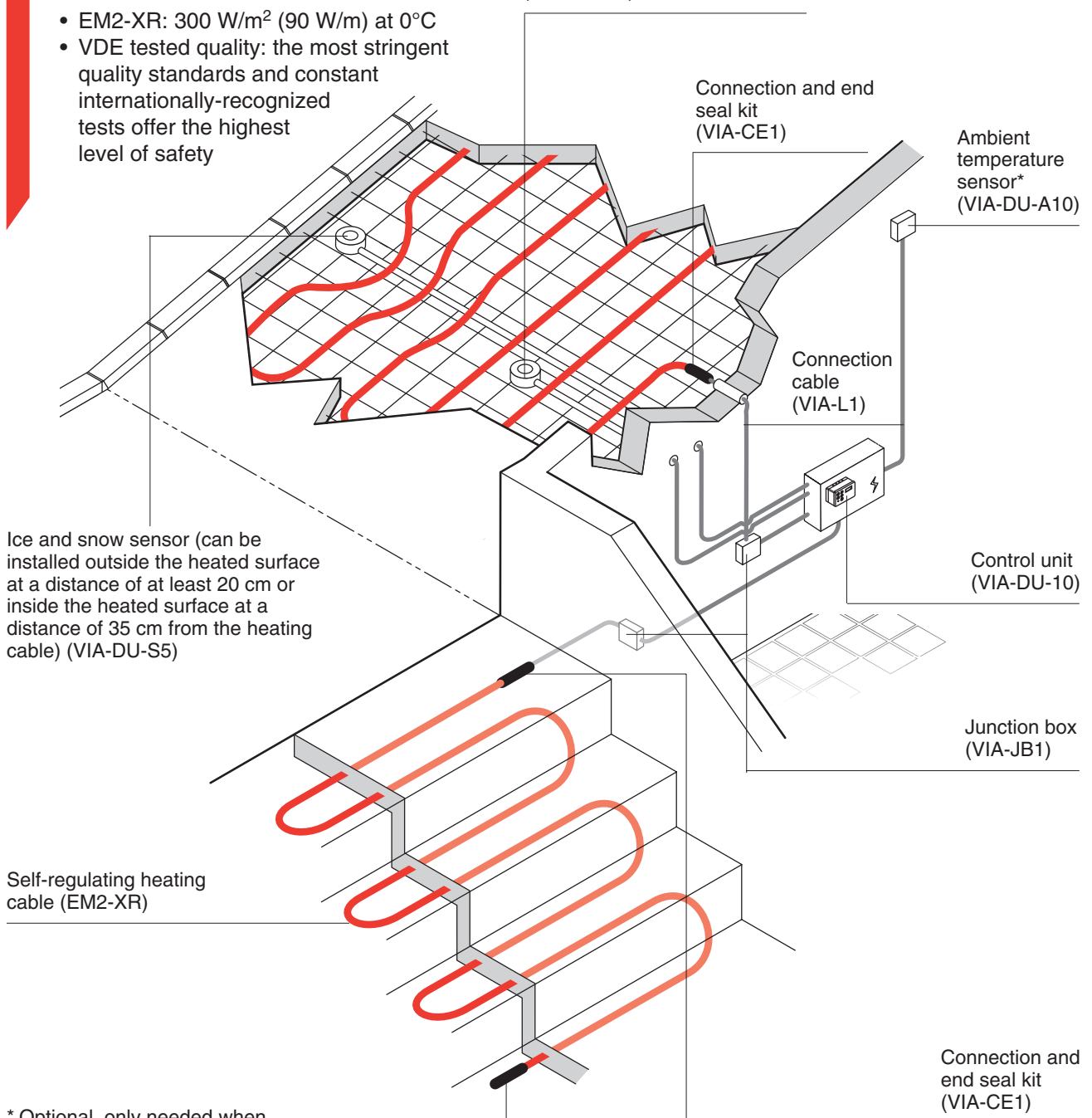

* Optional, only needed when "local detection" is selected.

Design guide and accessories

1. Application

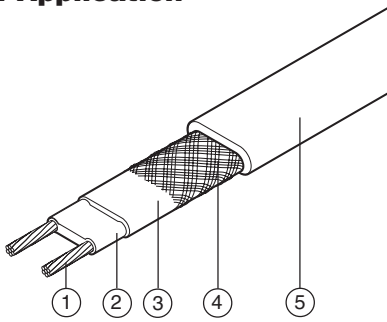

Footpaths, ramps, steps, basement garages, loading platforms.

Cable type	EM2-XR
Control	VIA-DU-10
Rating	300 W/m ² (90 W/m)

- Unsuitable for direct use in poured asphalt.
- When laying in concrete with a coating of at least 20 mm, an asphalt layer of max. 40 mm can be applied on the concrete surface (max. 240°C)

Technical data: see page 57

Composition

1. Copper conductor
2. Self-regulating heat element
3. Electrical insulation
4. Tinned copper braid
5. Protective jacket

2. Cable spacing

Concrete

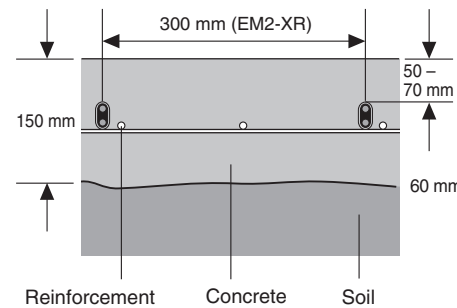

Sand bed

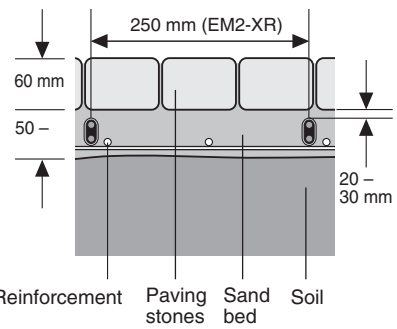

For installations in suspended constructions (e.g. bridges): apply heat insulation from below. The EM2-XR heating cable spacing is 250 mm. For other slab configurations, contact your Raychem representative.

Asphalt

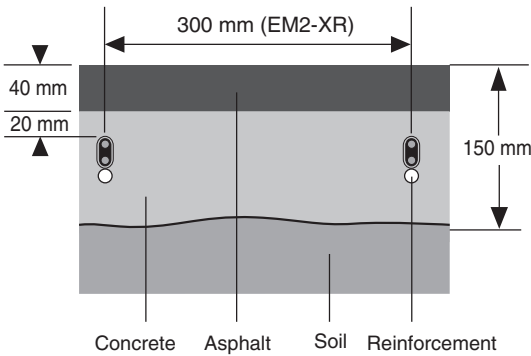

Concrete stairs

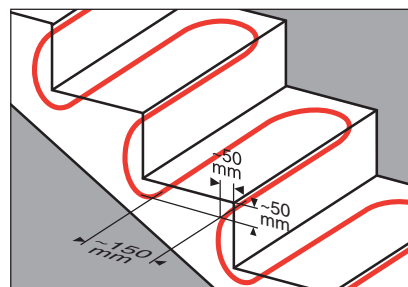

3. Determine area to be heated

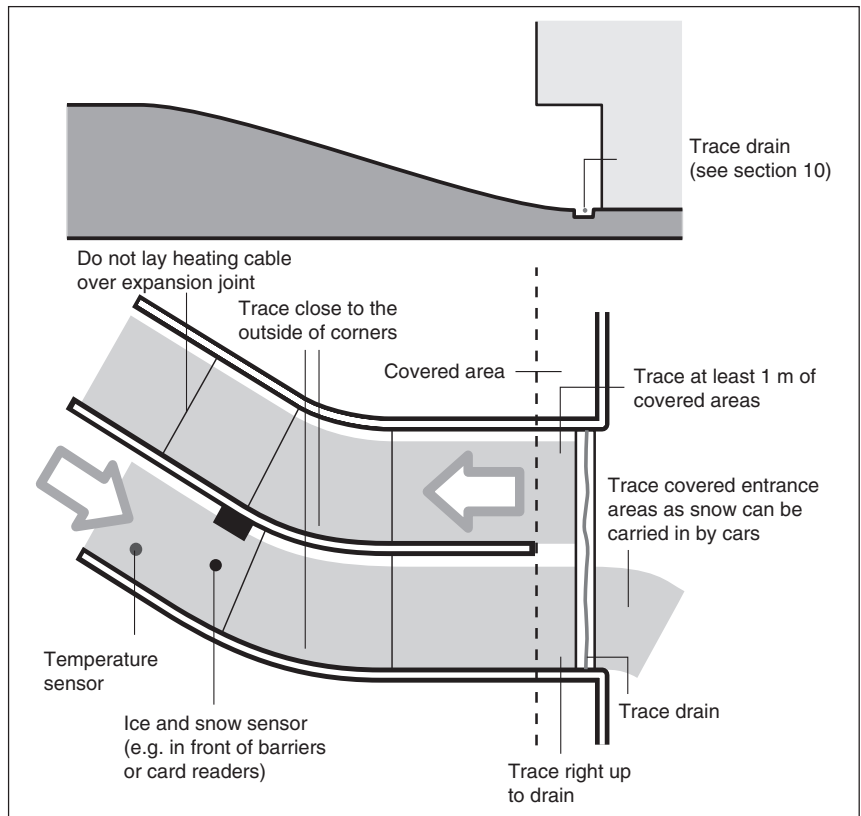

4. Heating cable length

A. Ramps and paths

$$\text{Heating cable length (m)} = \frac{\text{Total surface to be heated}}{\text{heating cable spacing (m)}}$$

B. Stairs

$$\text{Heating cable length (m)} = [2 \times \text{stair width (m)} + 0.4] \times \text{number of stairs} + 1 \text{ m (connection)}$$

5. Electrical protection

- According to local standards and regulations.
- Residual current device (rcd) 30 mA required, max. 500 m heating cable per rcd.
- Take into account the conductor size and max. admissible voltage drop.
- A higher voltage drop can occur at startup of heating.
- To determine the installed power with the electrical system designer, the nominal current of the series connected fuse or the current value at the system start-up temperature must be taken into account.

Circuit breaker sizing (MCBS to BS EN 60898, Type C)	Max. circuit length (for start-up at -10°C)
	EM2-XR
10 A	17 m
16 A	28 m
20 A	35 m
25 A	45 m
32 A	55 m
40 A	70 m
50 A	85 m

Provide the electrical system designer with all the necessary data.

6. Number of circuits

Min. number of heating circuits = $\frac{\text{Heating cable length (see section 4)}}{\text{max. length of heating circuit (see section 5)}}$

- The heating cable should not be laid over expansion joints.
- The heating cable should be distributed as symmetrically as possible.

7. Electrical connection

- According to local standards and technical regulations.
- The cross-section is determined according to the nominal current of the circuit-breakers and maximum admissible voltage drop.

8. Control units

The electronic control unit ensures that the surface heating only starts when the temperature falls below a certain threshold and moisture is detected on the relevant surfaces, ensuring efficient energy use.

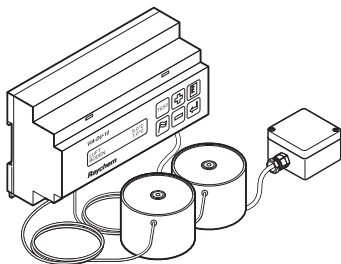

VIA-DU-10

Control unit with temperature sensor, ice and snow sensor and optional ambient temperature sensor.

- DIN-rail mounting
- Sensor cable length: 15 m
- Freezing rain precaution
- Optional BMS connection

Technical data: see page 30

9. Components and accessories

VIA-CE1

Waterproof connection and end seal

- Sealing compound and heat-shrinkable sleeve
- One kit required per heating cable circuit
- Connection of the heating cable and cold lead cable VIA-L1

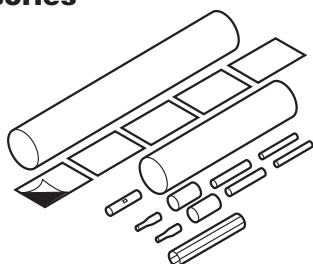

VIA-L1

Temperature-resistant cable (cold lead), 3 x 6 mm² Cu

- To be installed in conduit
- Maximum length for standard connection boxes: 65 m
- Maximum length with C 40 A and C 50 A circuit breakers: 5 m (VDE standard)

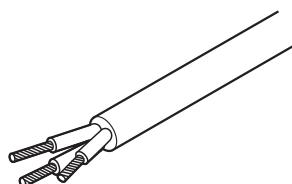

KBL-09

Cable ties for fixing heating cable to reinforced mesh

- One pack required for 30 m of self-regulating heating cable
- Pack of 100 pc.

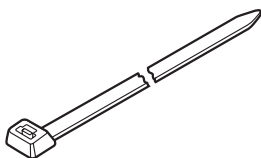

VIA-JB1

Temperature-resistant junction boxes

- For heating circuits up to C 50 A circuit-breakers
- Dimensions: 125 x 125 x 100 mm
- Pg 16 and Pg 21 entries (break-through)

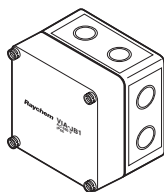

VIA-CTL-01

Crimping tool for connectors in VIA-CE1 connection and end seal kit

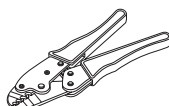

10. Drain tracing

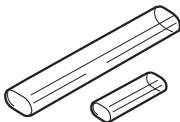
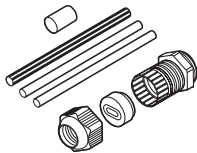
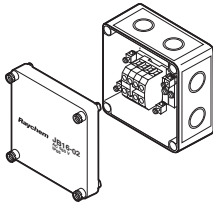
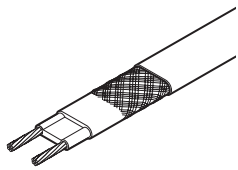
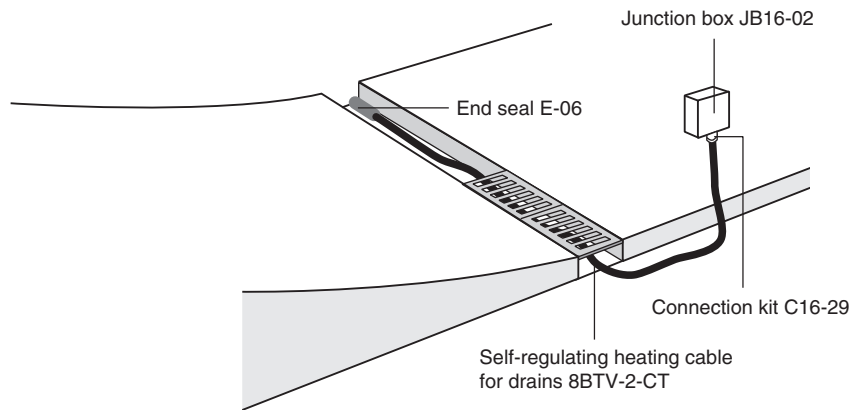

8BTV-2-CT

Drain heating cable with oil- and UV-resistant fluoropolymer outer jacket

JB16-02

Temperature-resistant junction and connection box
Dimensions: 94 x 94 x 57 mm

C16-29

Connection kit for BTV-CT
• Heat-shrink system (Pg16)

C25-21

Connection kit for BTV-CT
• Heat-shrink system (M25)

E-06

End seal kit for BTV-CT
• Heat-shrink system

- The drain heating system can be switched via the same control unit as the self-regulating surface heating system.
- Max. 60 m of 8BTV-2-CT can be connected to a 16 A C-type circuit-breaker.
- Residual current device (rcd) 30 mA required.

11. Technical data of control unit

Control unit VIA-DU-10

Layout

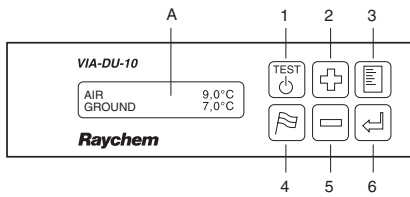

A. Display, illuminated (parameter and fault conditions)

1. Heater and unit test
2. Increase value, change settings (forwards)
3. Parameter menu
4. Language selection (D, GB, F, I)
5. Decrease value, change settings (backwards)
6. Enter

Technical Data

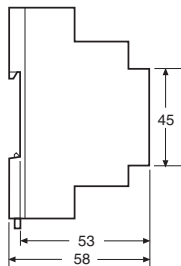
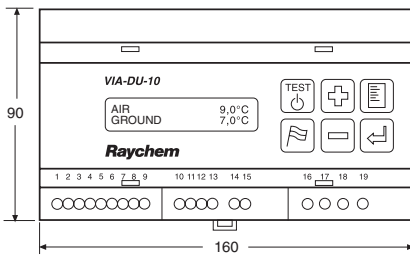

(Dimensions in mm)

Operating voltage	230 Vac., ± 10%, 50/60 Hz
Power consumption	14 VA max.
Protection class	II (in panel)
Main relay (heating)	I _{max} 4(1)A, 250 Vac. SPST, voltfree
Alarm relay	I _{max} 2(1)A, 250 Vac. SPST, voltfree
Switching accuracy	±1 K
Display	DOT-Matrix 2 x 16 characters
Mounting	DIN-rail
Housing material	Noryl
Terminals	0,5 to 2,5 mm ²
Ingress protection	IP20
Weight	750 g
Exposure setting	0°C to +50°C

Main parameters

Temperature setting	0°C to +6°C
Moisture setting	Off, 1 (moist) to 10 (very wet)
Min. heating time	Off, 10 to 120 min (heating switched on)
Min. temperature	Off, -15°C to -1°C
Freezing rain precaution	Auto, Weather forecast, Off
Overruling	Off, On, BMS

Parameters are stored in non-volatile memory.

Temperature sensor (non-heated, marked blue) VIA-DU-S4

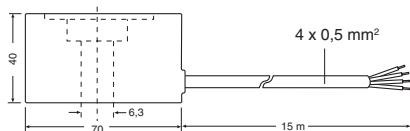

Sensor type	NTC
Ingress protection	IP65
Sensor cable	4 x 0,5 mm ² , Ø 5,7 mm
Sensor cable length	15 m, extension up to 50 m (4 x 1,5 mm ²)
Exposure temperature	-30°C to +80°C

Ice and snow sensor (heated, marked yellow) VIA-DU-S5

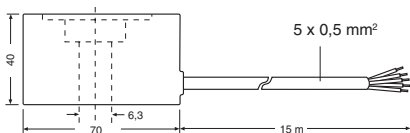

Operating voltage	8 V DC (from controller)
Sensor type	NTC
Ingress protection	IP65
Sensor cable	5 x 0,5 mm ² , Ø 5,7 mm
Sensor cable length	15 m, extension up to 50 m (5 x 1,5 mm ²)
Exposure temperature	-30°C to +80°C

Ambient temperature sensor* VIA-DU-A10

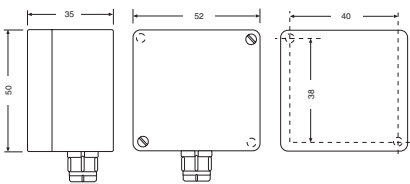

Pg9

Sensor type	PTC
Ingress protection	IP54
Terminals	1,5 to 2,5 mm ²
Sensor cable	2 x 1,5 mm ² , max. 100 m (not included)
Exposure temperature	-30°C to +80°C
Mounting	Wall mounting

* Installation not mandatory if "Sleet precaution" is not set to "Auto".

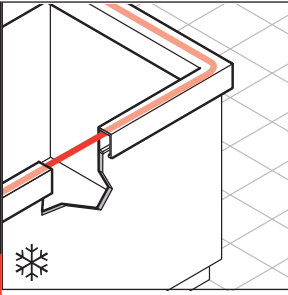

FreezGard system

Raychem**Self-regulating frost protection for the refrigeration industry**

- Frost protection of drainpipes, doors and cold rooms
- Prevention of condensation build-up on refrigerated display windows
- Enhanced reliability and safety
- Energy-saving and economic
- Easy planning and installation

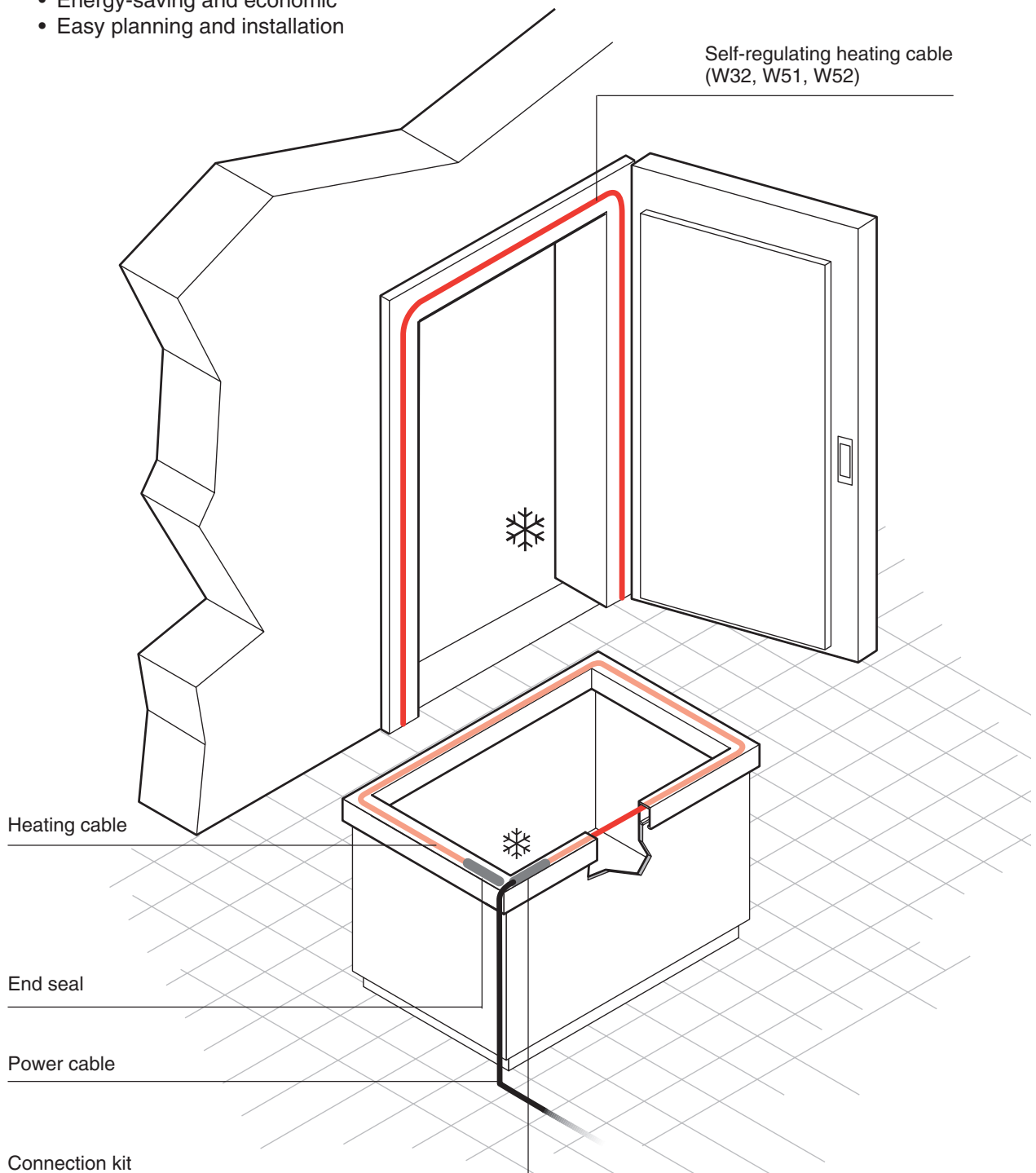

Technical data

	FreezGard-Gardian W32	FreezGard-Gardian W51	FreezGard-Gardian W52
Rating (W/m at 5°C)	10 W/m	15 W/m	15 W/m
Nominal voltage	240 Vac	110 Vac	240 Vac
Maximum exposure temperature			
• constant operation	50°C	50°C	50°C
• intermittent operation	85°C	85°C	85°C
Dimensions			
• thickness (in mm)	5.8	5.8	5.8
• width (in mm)	8.5	8.5	8.5
Insulation	modified polyolefine	modified polyolefine	modified polyolefine
Outer jacket	modified polyolefine	modified polyolefine	modified polyolefine
Minimum assembly temperature	-20°C	-20°C	-20°C
Minimum bending radius	10 mm	10 mm	10 mm
Maximum length of heating cable per heating circuit (switch-on temperature at 10°C)			
Electrical protection 16A	80 m	50 m	75 m

For maximum protection of persons and installations, Raychem requires a 30 mA residual current device (rcd).

Components

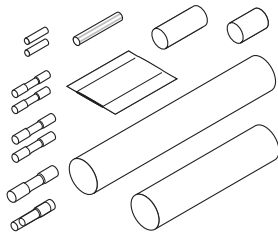

CCE-03-CR

Cold lead connection and end seal kit

- Connection of 3 x 1.5 mm² or 3 x 2.5 mm² cold lead cable to self-regulating heating cables WinterGard FS-A, FS-B, HWAT, IceStop GM-2X and FreezGard

Assembly

Specific assembly instructions are supplied with each kit. The assembly must be carried out by a qualified person.

Leak detection and location system

- Monitoring of large surfaces
- Pinpointing of leaks
- Pre-assembled and ready to use

For further information, contact your representative

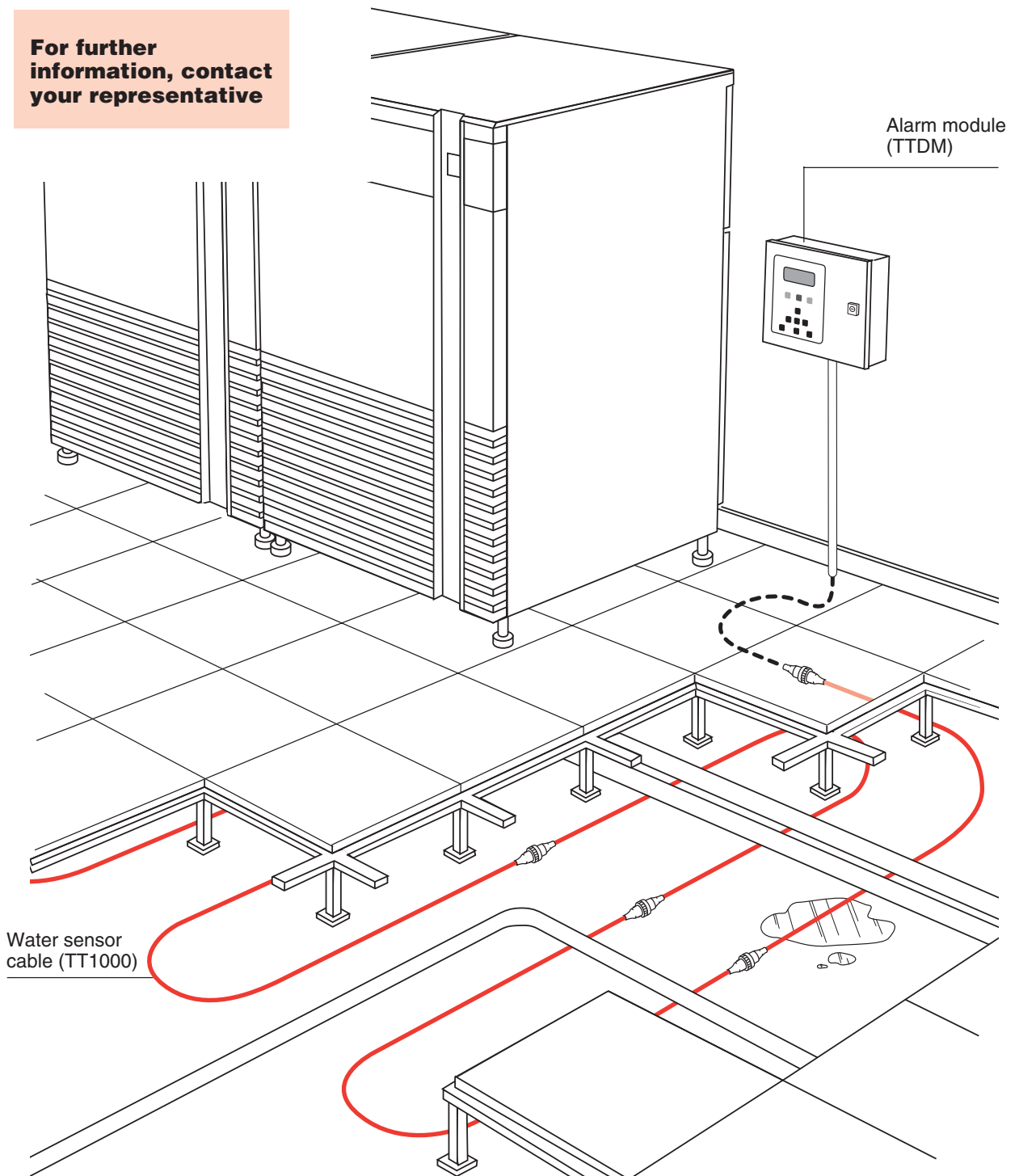

Self-regulating gentle underfloor heating for new constructions and converted buildings

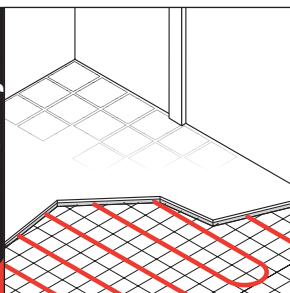

- Underfloor heating for added comfort
- Timer for individual control
- Flexible - suitable for any floor
- Minimum depth requirement: 15 mm
- Follow the instructions of the floor covering manufacturer

Energy-saving

- 5LC2-CT: 15 W/m at 25°C in floor screed

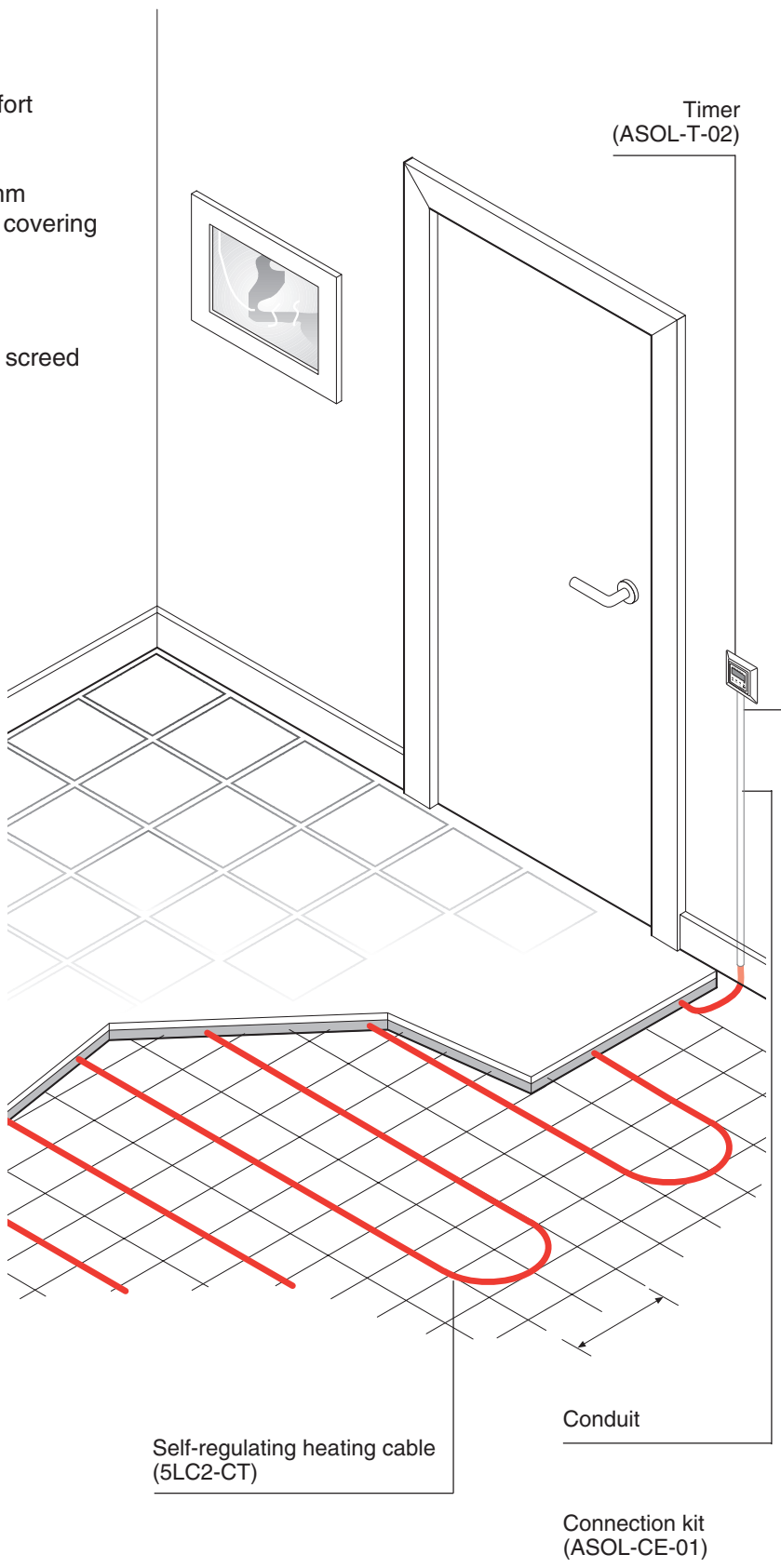

5LC2-CT

Self-regulating heating cable

- Spacing: 160 mm (equivalent to $\pm 6 \text{ m/m}^2$)

Technical data: see page 55

Accessories

ASOL-T-02

Timer with 7-day programming

ASOL-CE-01

Connection kit

CCE-04-CT

Cold lead connection and end seal kit

ASOL-BX-02

Junction box

ASOL-S-01

Connection

Electrical protection

- Supply voltage 230 Vac
- rcd 30 mA required

Max. cable length

According to minimum start-up temperature of 15°C

Circuit-breaker (C type)	Max. cable length
3A	32 m
6A	65 m
10A	100 m

General installation instructions

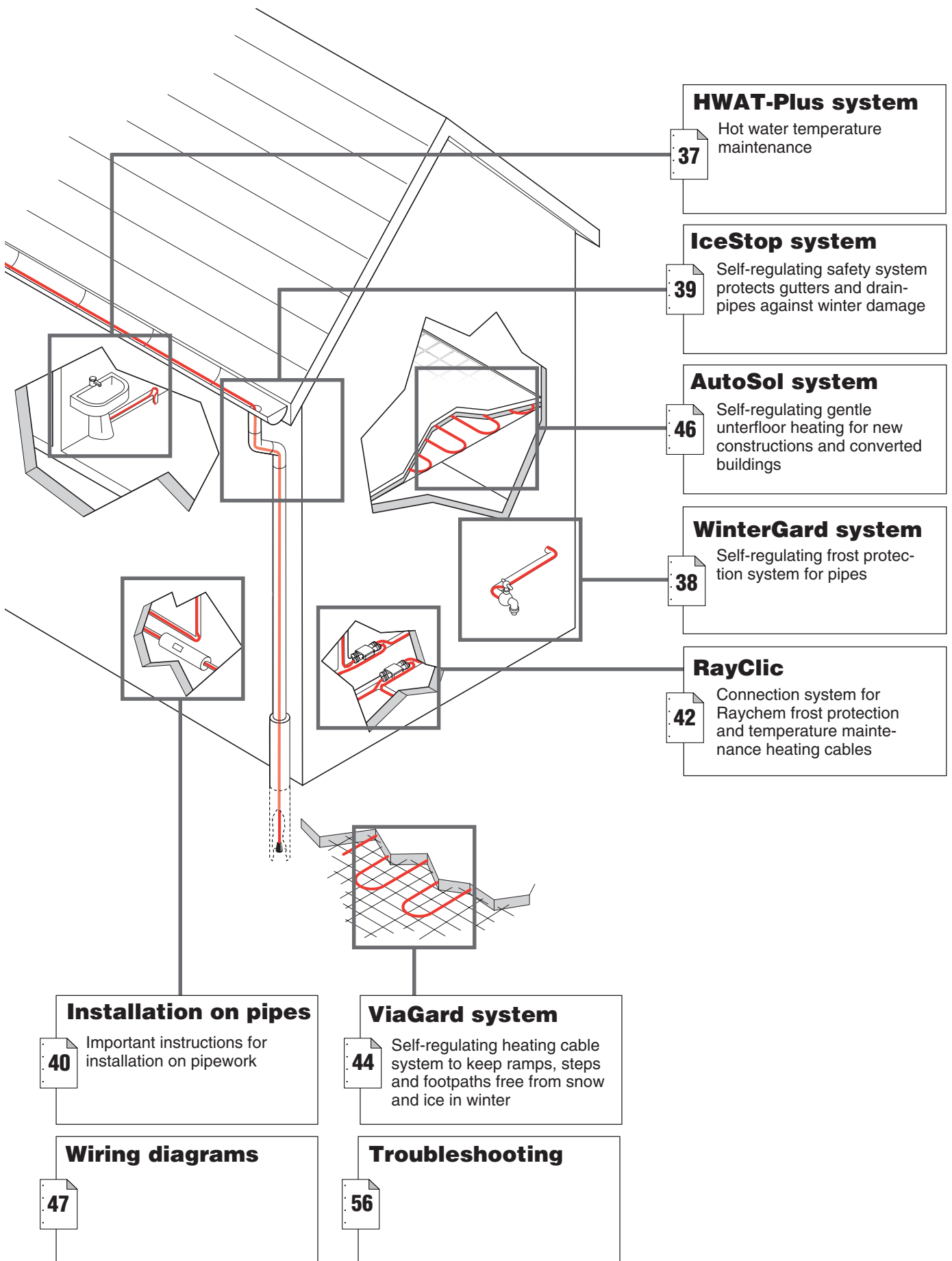

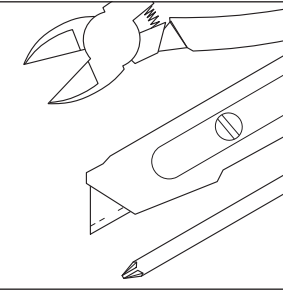

Assembly and mode of operation **Raychem**

Raychem self-regulating heating cables

Tested service life

Intensive tests according to recognized scientific procedures
Results: self-regulating heating cables have a service life of at least 20 years.

Approvals

- Stringent production monitoring
- Approved BS 6351
- VDE and ÖVE approved



Robust construction

- Long service life assured through electrical polyolefin or fluoropolymer insulation

Energy-saving

- Power output is always adjusted to the amount of heat required at any given time
- Raychem self-regulating heating cables save energy and operating costs

Safe and reliable

- Thanks to self regulation, no risk of overheating or burnout even where cables overlap
- Safe for use on plastic pipes or gutters



Parallel circuit

- Current conduction between two parallel copper conductors across the semiconducting, crosslinked heating element. The cable can therefore easily be cut to length on site.

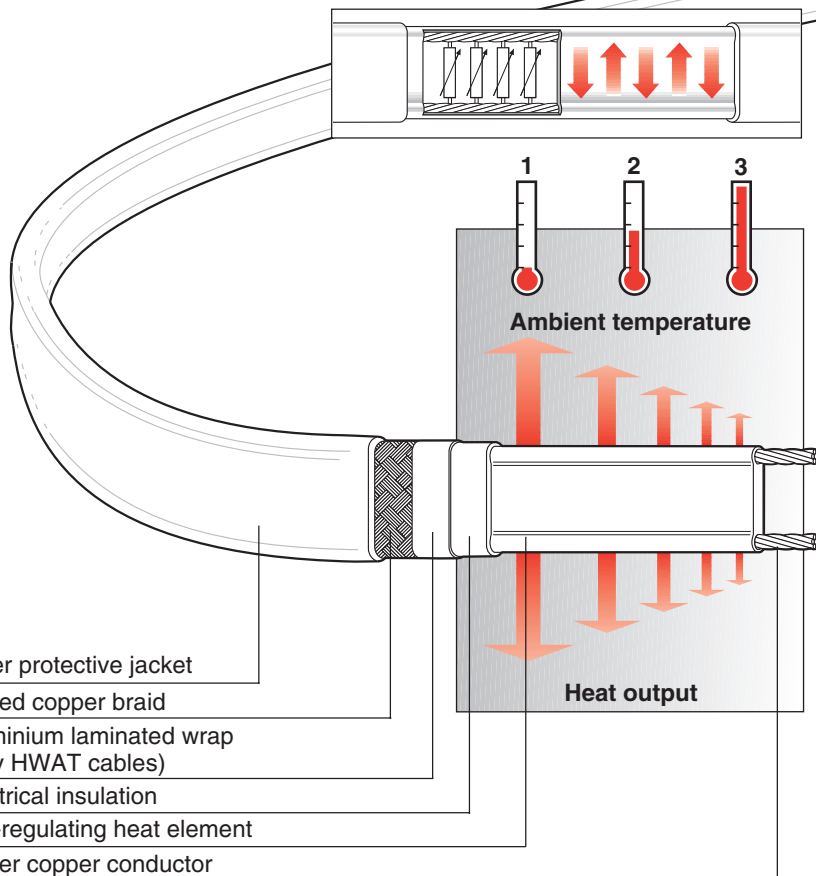
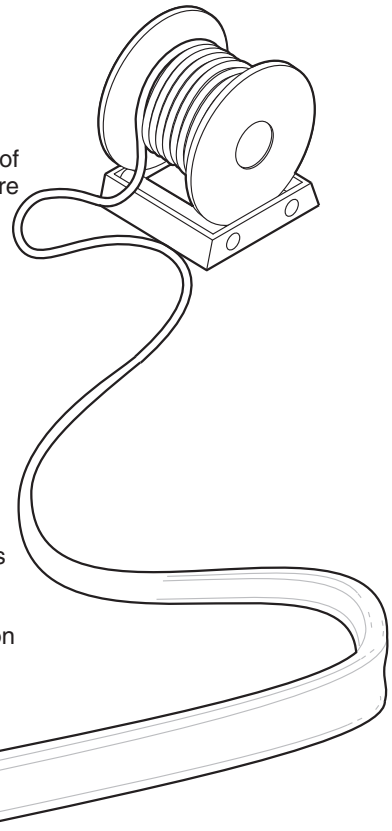

1. Cold ambient temperature = High power output

If the temperature in the immediate vicinity of the Raychem self-regulating temperature maintenance heating cable is cold, the heat output from the heating cable is increased. The polymeric core of the cable contracts, which creates many electrical paths across the integrated, carbon particles.

2. Warm ambient temperature = Low power output

In response to a warmer environment, the heat output of the Raychem self-regulating cable is reduced. The polymeric core of the cable expands, reducing the electrical paths.

3. Warm ambient temperature = Virtually no power output

If the temperature in the environment of the Raychem self-regulating heating cable reaches a high temperature, the heat output is practically cut off. Due to the maximum expansion of the polymeric core of the cable, almost all the electrical paths are cut off.

HWAT-Plus system

Hot water temperature maintenance

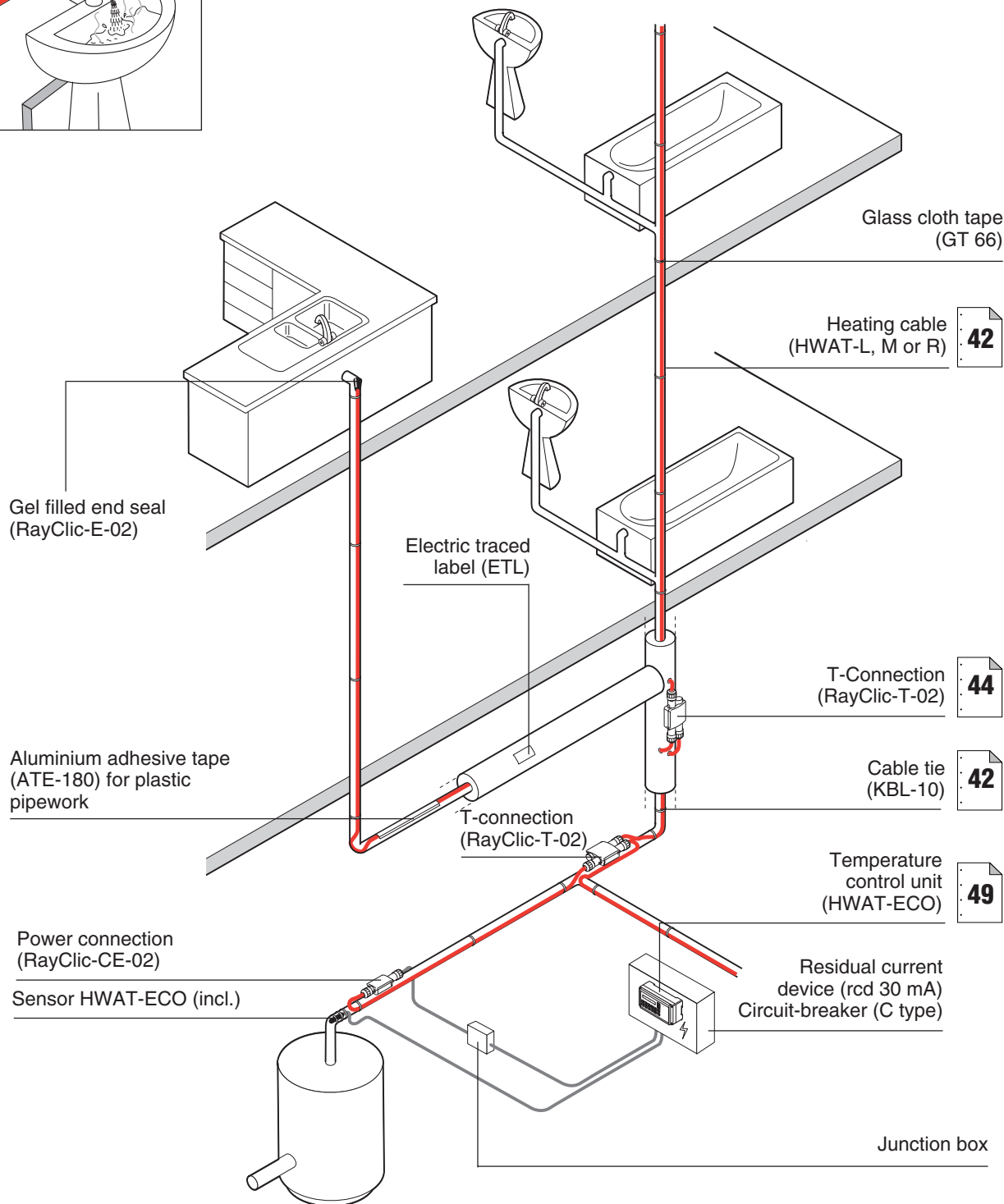
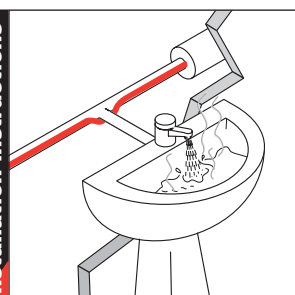

Checklist for planning the installation

The HWAT-Plus system design should take into account:

- Pipe diameter and material
- Insulation type and thickness
- Ambient temperature
- HWAT-Plus circuits should divide the plumbing into logical segments.
- Don't exceed the maximum circuit length.
- Show connection locations on the drawings.
- Locate power connections near the electrical panel.
- Locate T-connections in accessible areas.

WinterGard system

Self-regulating frost protection system for pipes

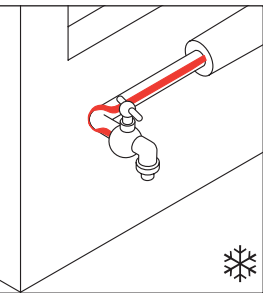

Residual current circuit-breaker (rcc 30 mA)
Circuit-breaker (C type)

Thermostat with line or ambient temperature sensor

49

Power connection (RayClic-CE-02)
(Not for FS-C-2X)

Junction box (JB16-02)

End seal (RayClic-E-02)

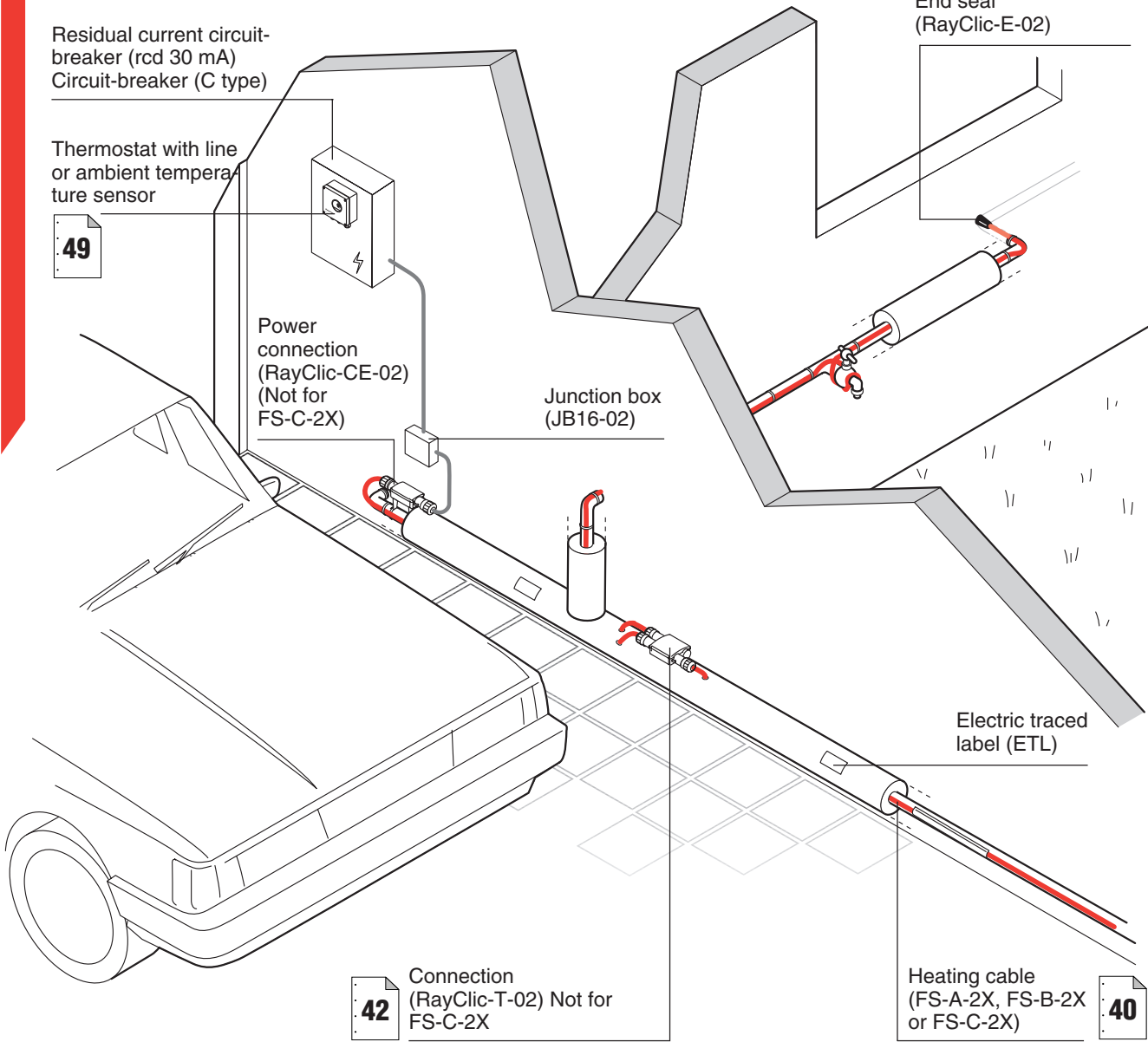

42

Connection (RayClic-T-02) Not for FS-C-2X

Heating cable (FS-A-2X, FS-B-2X or FS-C-2X)

40

Placing of sensor

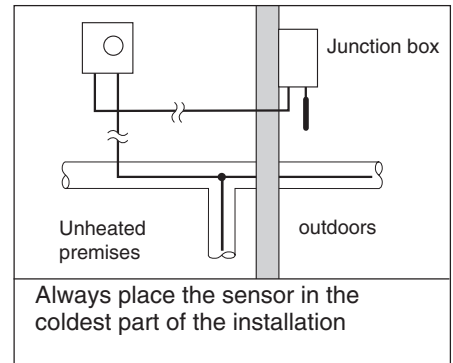
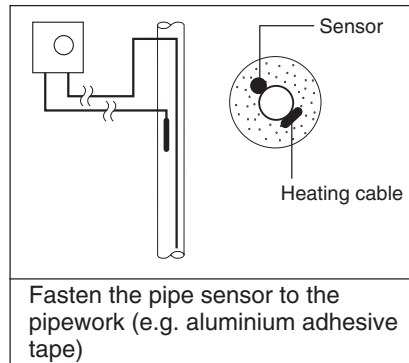
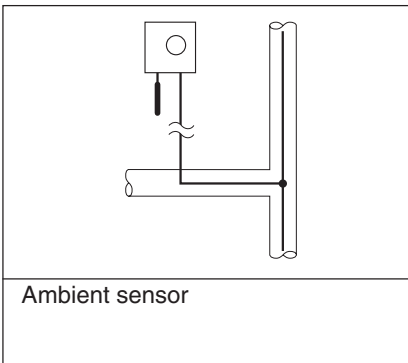

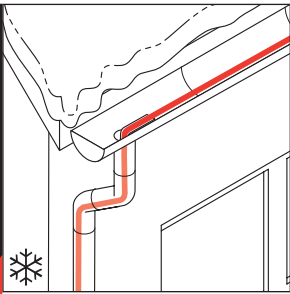

IceStop system

Installation instructions for IceStop

- Tapered / Valley Gutter**
 Wide gutters (> 300 mm) may require more than one flow path
- Box Gutter**
 Typically one heating cable per gutter located adjacent and parallel to the lead roll overlap
- Hopper / Chute Outlet / Catch Pit**
 Pass heating cable through all outlets to create and maintain a continuous flow path. This avoids transferring the problem to another location
- Transition zones: GM-RAKE edge protection bracket prevents tilting**
- Fastening of the gutter cables:** on the roof, eaves bricks, gutter and drainpipe with GM-RAKE edge protection brackets (incl. cable ties)

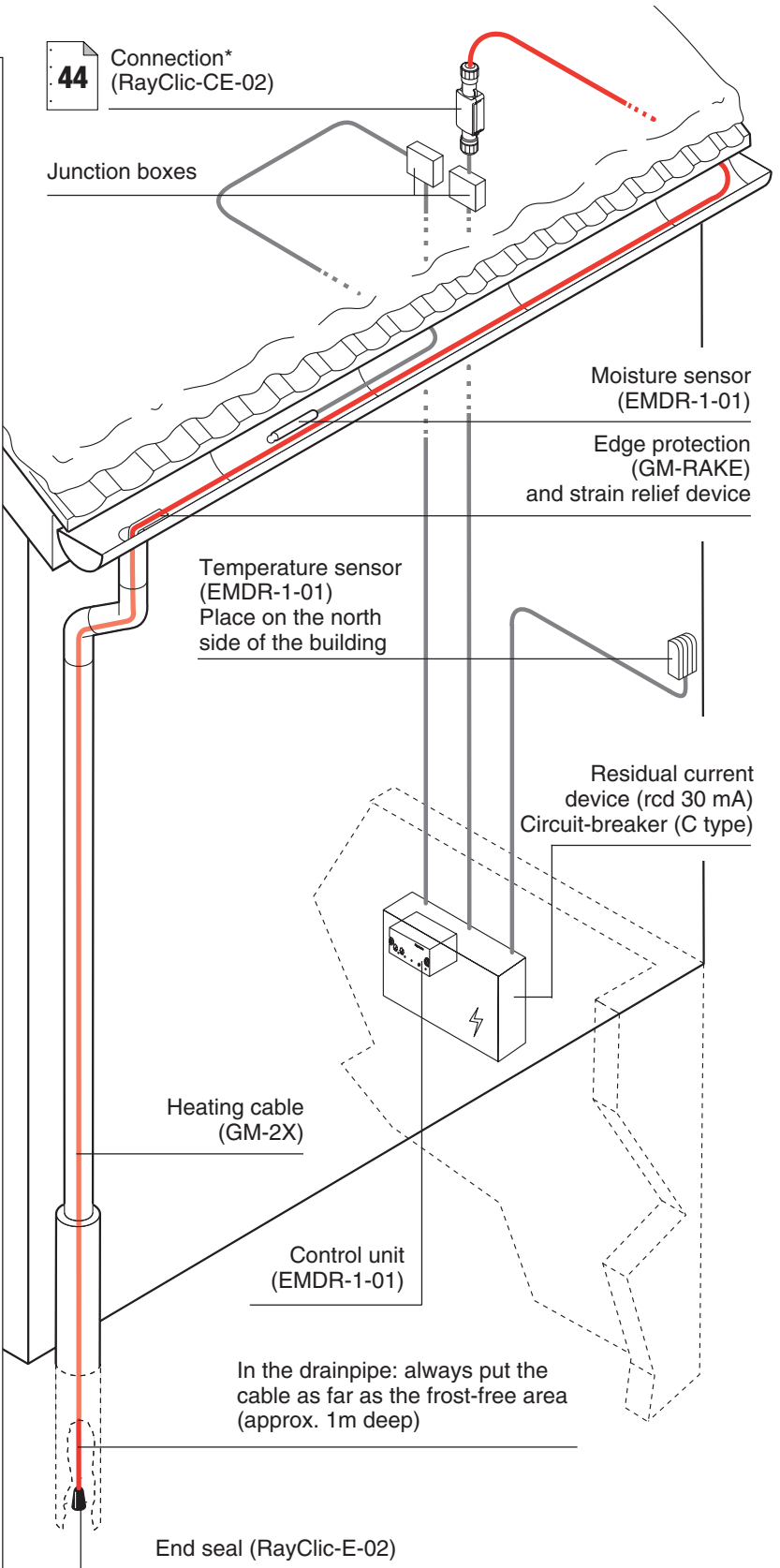

* Avoid installing RayClic on places where it is immersed in water

Installation instructions for HWAT and WinterGard cables

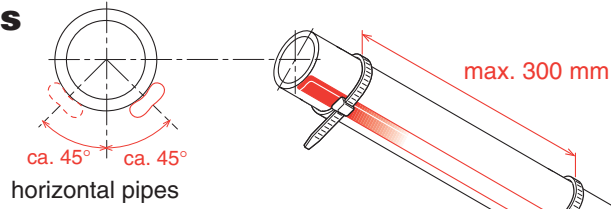

- The heating cable should be installed in a straight line on the pipework.
- Lay on dry surfaces
- Minimum installation temperature: -10°C

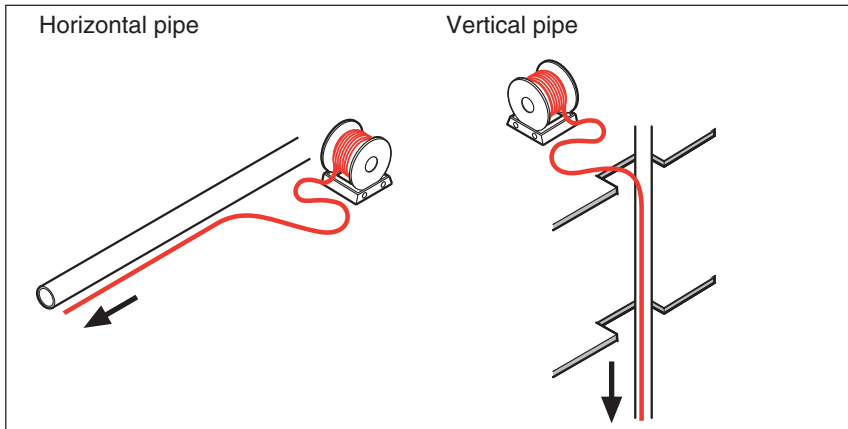

Cable tie KBL-10

For plastic pipes, use aluminium adhesive tape ATE-180. Place it over the entire length of the pipe.

GT-66 adhesive tape

It is not necessary to spiral the cable around the pipe

Install the heating cables on the outside of the pipe bend

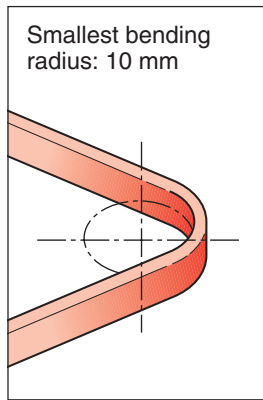
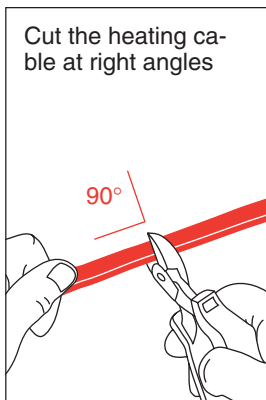

Installation of Raychem self-regulating heating cables

Store in a dry and clean place
Temperature range: -40°C to +60°C
Protect any cable ends with an end seal

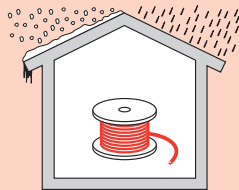

Avoid:

- sharp edges
- high tractive force
- kinking and crushing
- walking or driving over the cable
- moisture at cable interfaces

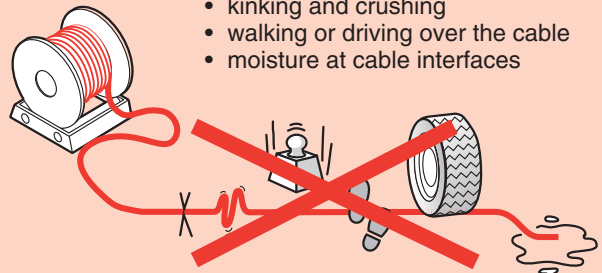

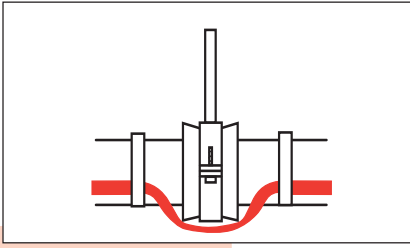

- Run the cable over pipe suspensions
- Do not clamp the cable

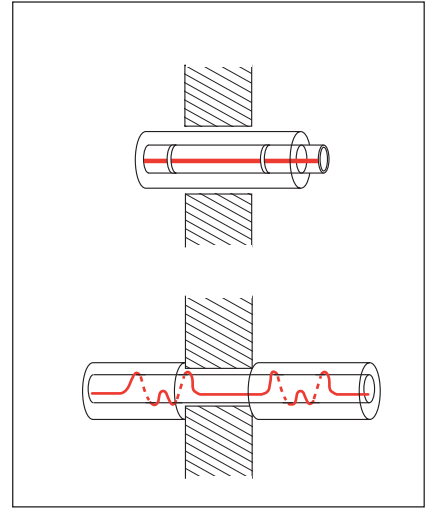
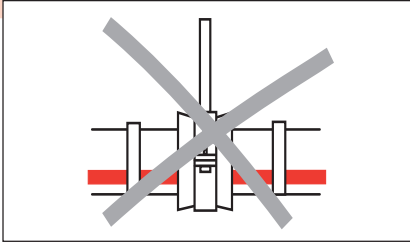

Wall/Floor transit

The thickness of thermal insulation must be continuous otherwise compensate by adding heating cable.

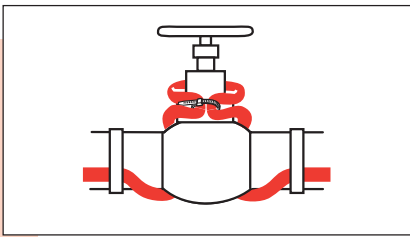

Frost protection at valves:

- Valves up to 2" (DN 50): lay the temperature maintenance and frost protection heating cables in a straight line
- From 2": lay as shown
- Always insulate valves

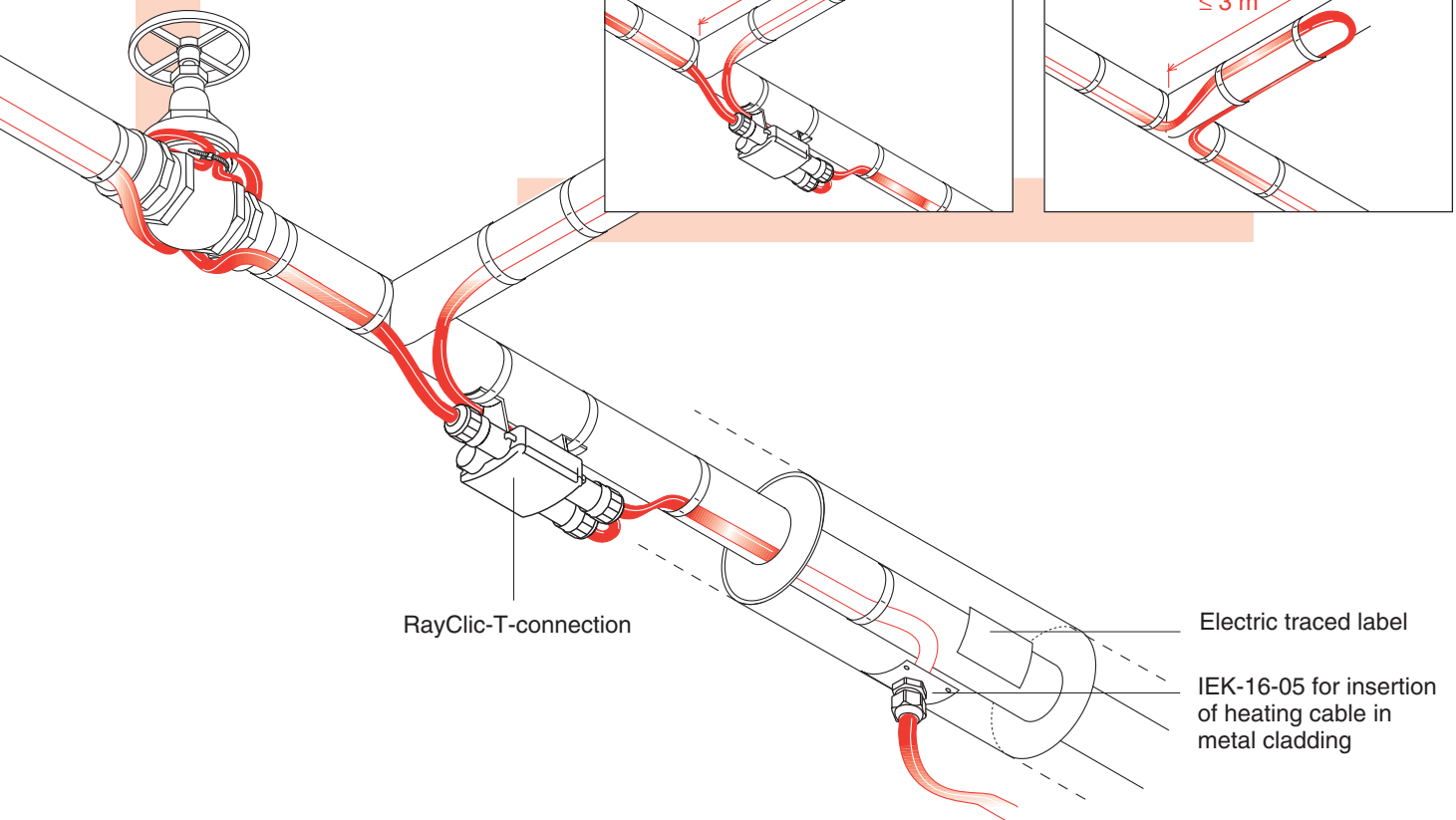
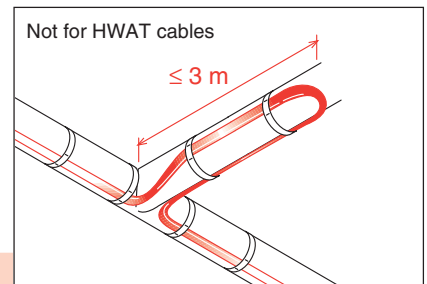
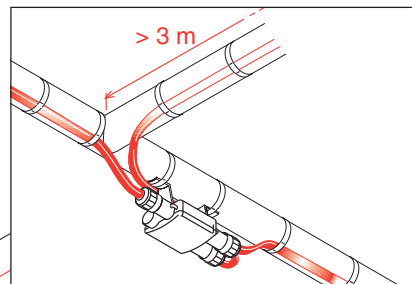
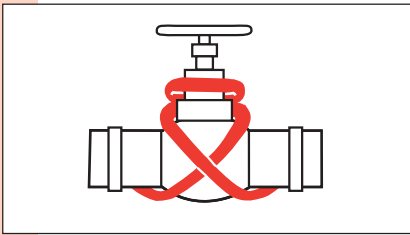

RayClic-T-connection

Electric traced label

IEK-16-05 for insertion of heating cable in metal cladding

Installation instructions for RayClic fast connection systems and end seals

Connections

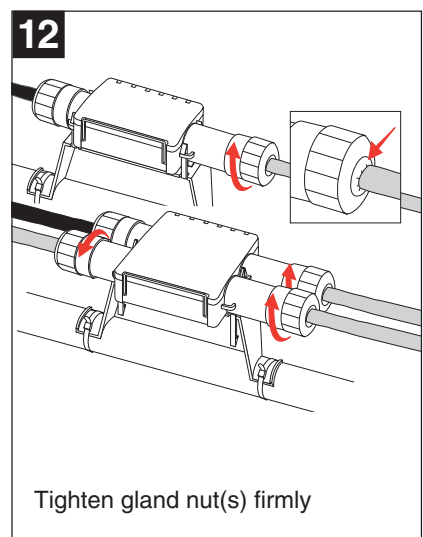
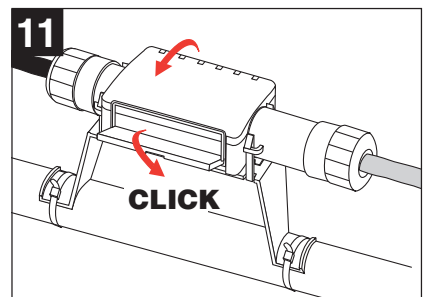
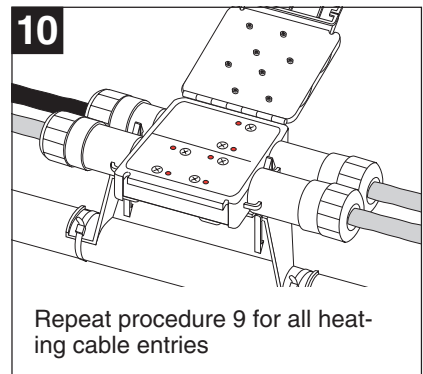
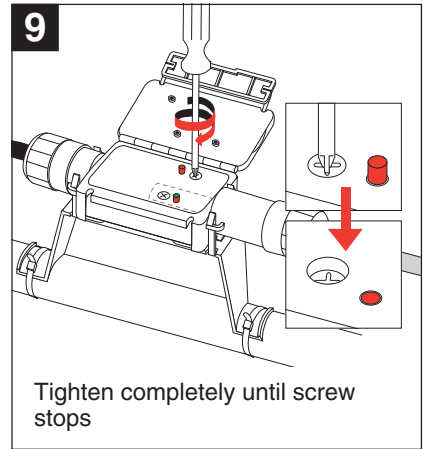
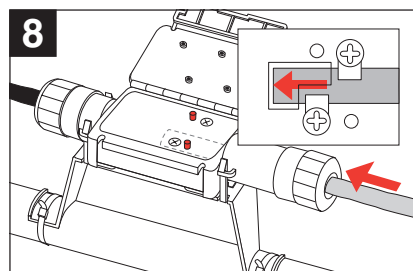
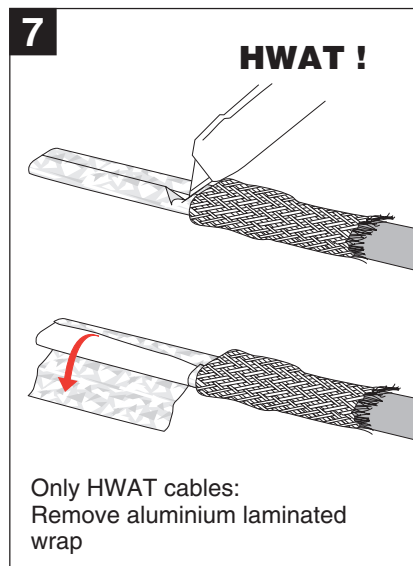
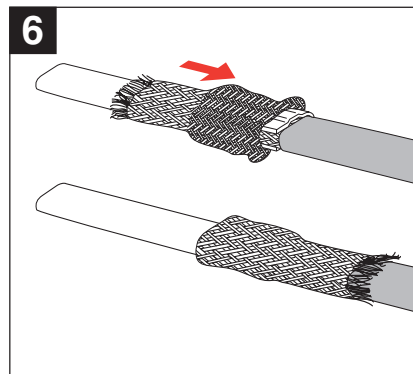
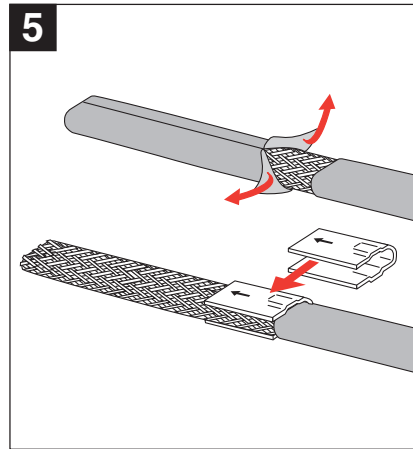
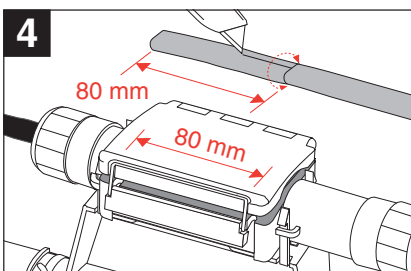
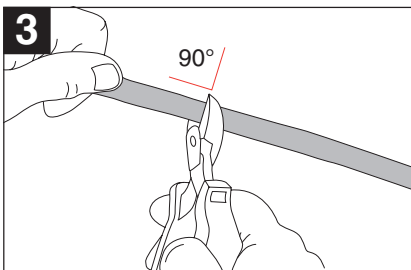
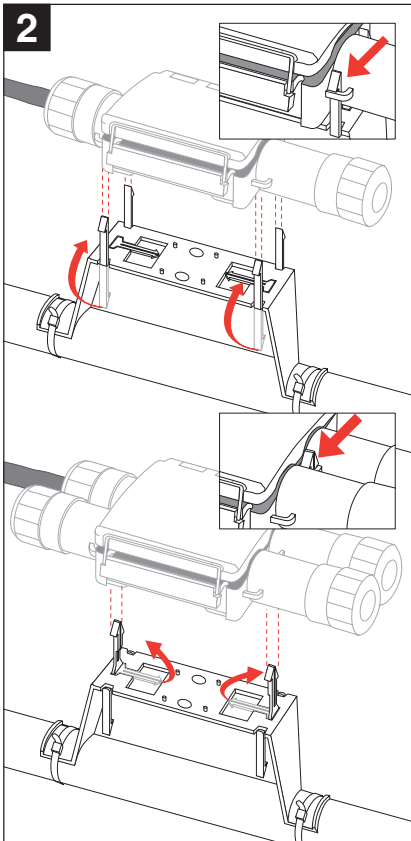
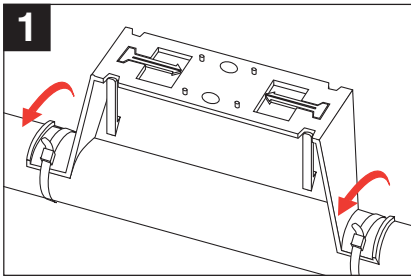

End seals

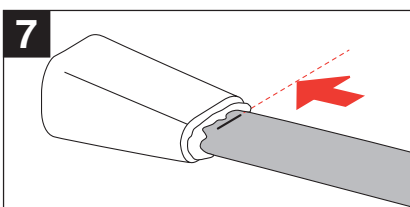
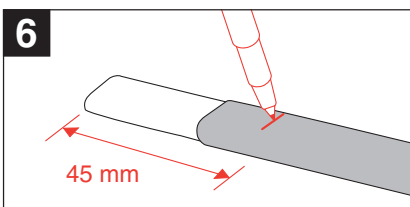
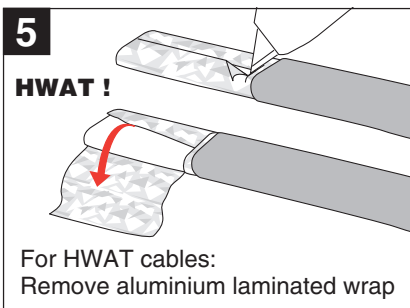
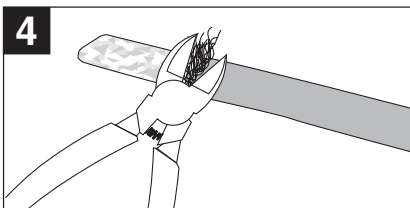
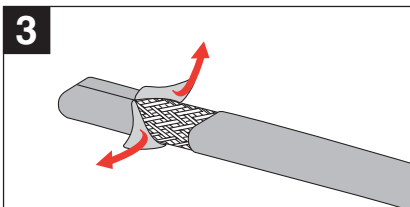
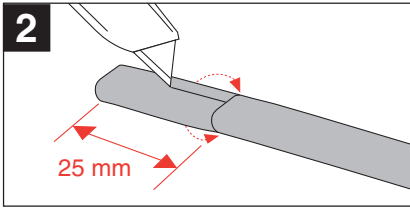
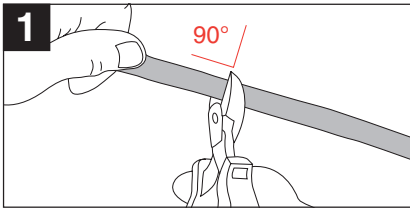

Use only in combination with the following Raychem self-regulating heating cables: HWAT-L, HWAT-M, HWAT-R, IceStop GM-2X, WinterGard FS-A-2X, FS-B-2X.

For WinterGard FS-C-2X and BTV types, use heat-shrinkable products.

What type of RayClic do you need?

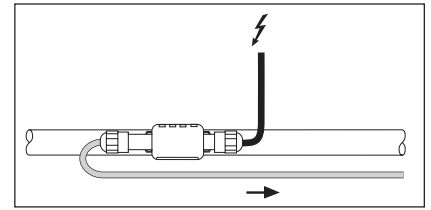

RayClic-CE-02 power connection

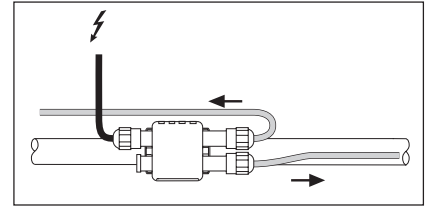

RayClic-PS-02 power connection for 2 cables

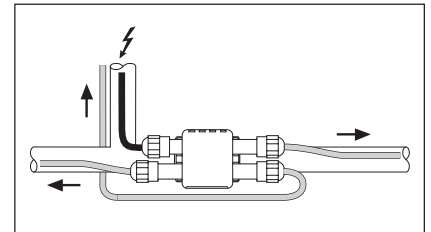

RayClic-PT-02 power connection for 3 cables

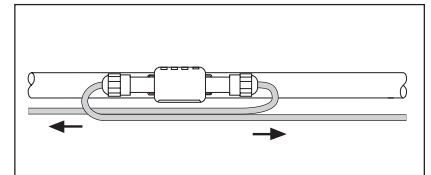

RayClic-S-02 splice

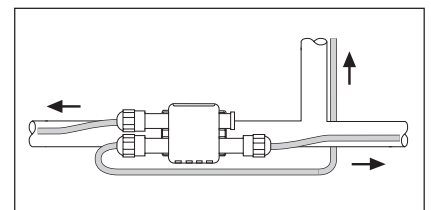

RayClic-T-02 T-connection

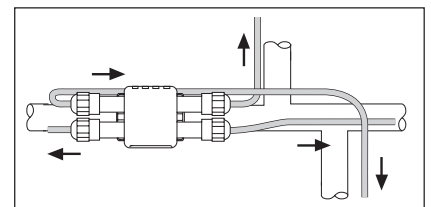

RayClic-X-02 4-way connection

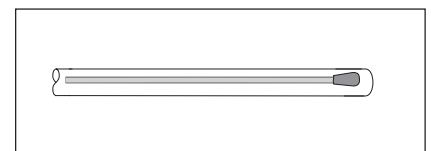

RayClic-E-02 end seal

Self-regulating heating system that keeps ramps, steps and footpaths free of snow and ice

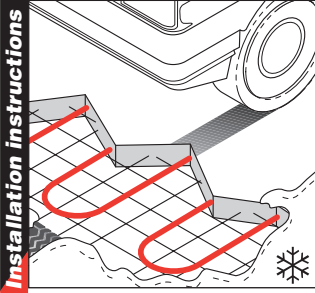

Installation instructions

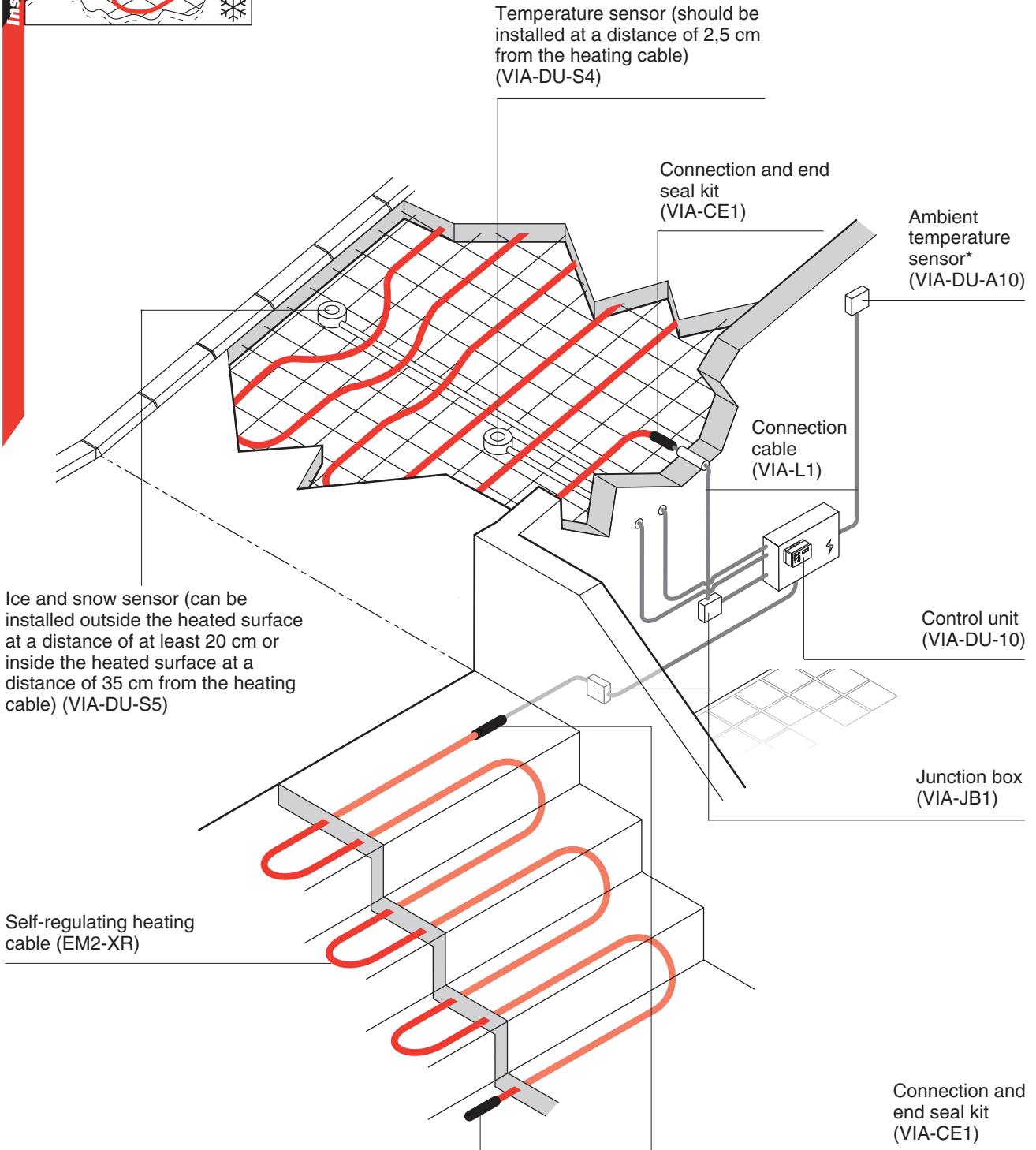

For the complete installation instructions, follow the ViaGard system assembly instructions (supplied with VIA-CE1 package)

* Optional, only needed when "local detection" is selected.

1

The heating cable should not be applied over expansion joints. Lay a separate heating circuit on either side of the expansion joint.

For cornered ramps, always follow the curve (in this way, you ensure that the laying spacing is maintained). Trace as close as possible to the outside of corners

The heating cable should preferably be laid in long runs rather than in short runs.

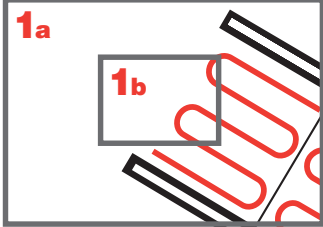

Place temperature and moisture sensors in the middle of the ramp between the traffic lanes

Trace braking areas (e.g. in front of barriers or card readers)

Covered area

Trace at least 1 m of covered areas

Heating of the drain

Trace covered entrance areas as snow can be carried in by cars

Trace right up to drain

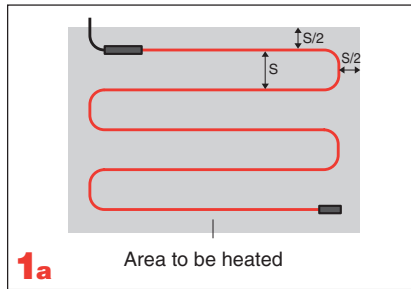

1a

Area to be heated

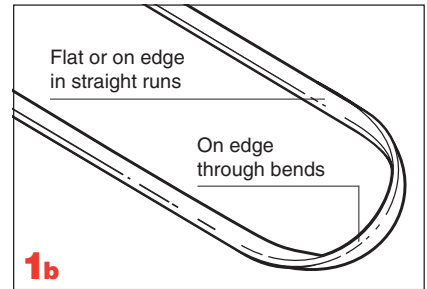

1b

Spacing (S)

Concrete

Sand

EM2-XR

300 mm

250 mm

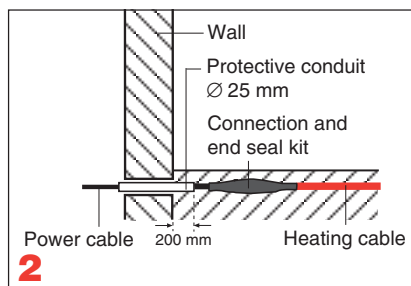

2

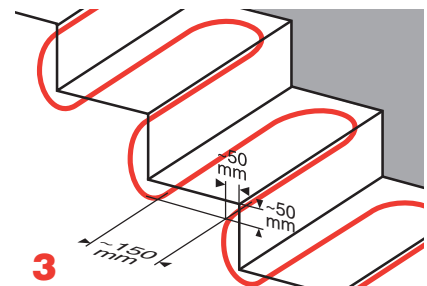

3

AutoSol system

Self-regulating gentle underfloor heating for new constructions and converted buildings

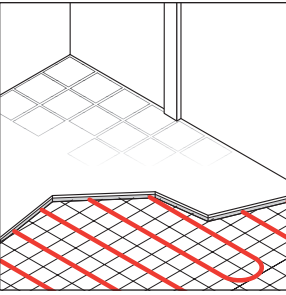

Floor Configuration WITHOUT Existing Thermal Insulation

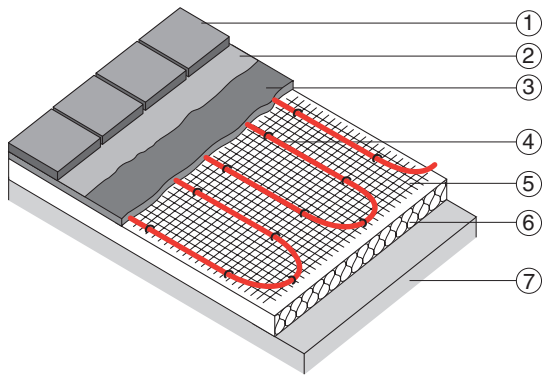

Floor Configuration WITH Existing Thermal Insulation

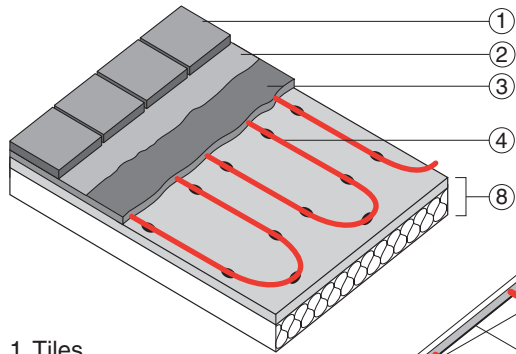

- 1 Tiles
- 2 Tile adhesive
- 3 Special (self-levelling) mortar for floor heating systems
- 4 5LC2-CT AutoSol self-regulating heating cable
- 5 Mesh (chicken wire)
- 6 High density polystyrene insulation (thickness 30-50 mm)
- 7 Existing floor (tiles, wood, PVC,...) without thermal insulation
- 8 Existing floor (tiles, wood, PVC,...) with thermal insulation

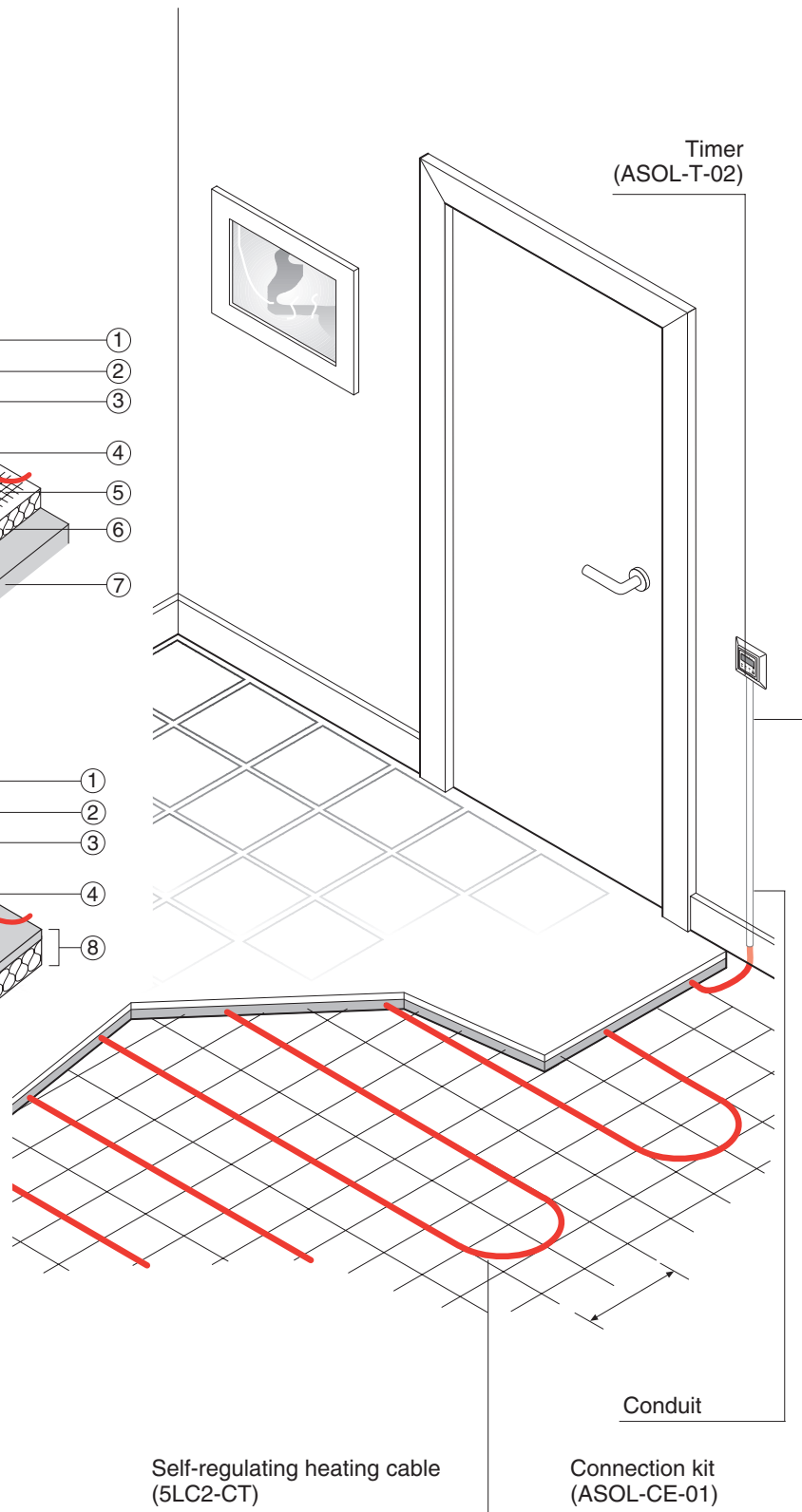

Please consult the complete AutoSol System installation instructions (included in the kit).

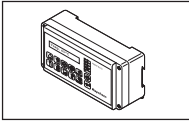

Wiring diagram for HWAT-Plus system with HWAT-ECO temperature control unit

Wiring diagram for HWAT-R/HWAT-M with temperature control unit HWAT-ECO

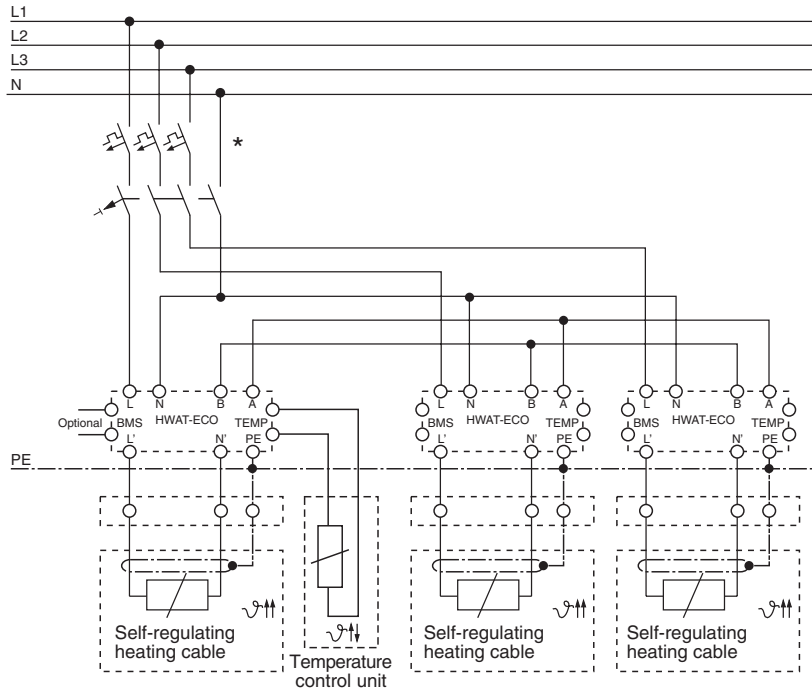

* Two- or four-pole electrical protection by circuit-breaker may be needed for local circumstances, standards and regulations

HWAT-ECO Temperature control unit

HWAT-ECO Temperature control unit

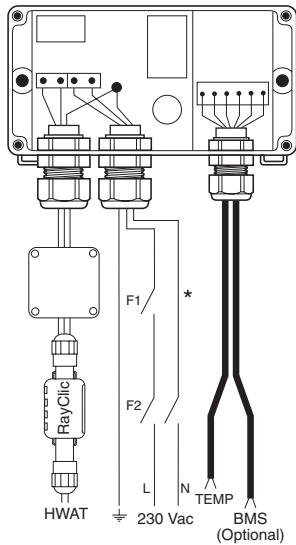

F1 = Circuit-breaker (C type) 20 A

F2 = rcd 30 mA

* = Double-pole electrical protection may be needed for local circumstances, standards and regulations

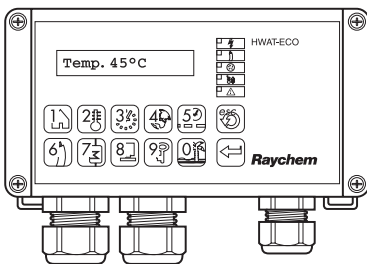

1. Electrical connection: See diagram

2. Programming:

The HWAT-ECO has 9 different building specific time/ temperature programmes. These programmes are based on Raychem's long experience for optimum comfort and energy saving. For user specific changes in the programming, the Edit timer programme can be used*.

In most cases this Quick installation guide will be enough to get the HWAT-ECO working most satisfactory. Please follow the next list for a quick installation:

After power On the Display will blink the following line: 01-01-1998 00:00

1. Press Key (3) and enter the correct month, date, year, hours and minutes.
2. Press Key (4) three times to select the language.
3. Press Key (6) several times until the correct type of heating cable is displayed.
4. Press Enter to confirm the heating cable choice.
5. Now enter the length of the connected heating cable by pressing the number keys.
6. Press Enter to confirm the heating cable length.
7. Now enter the ambient temperature of the heating cable. Default is 20°C and values of 10 up to 25°C are accepted.
8. Press Enter to confirm the ambient temperature.
9. Look for the correct building programme (See table below) in the Appendix of the HWAT-ECO installation manual supplied with the unit.
10. Press Key (1) until the correct programme shows on the display and press Enter to confirm.
11. The display will now show the Time/Date and after 5 seconds the display will show the temperature of the current timer block. The error light and buzzer should be off.

Programme name	Building type
Programme 0	Constant temperature ($\pm 55^{\circ}\text{C}$)
Programme 1	Apartment block
Programme 2	Family home
Programme 3	Prison / Barracks
Programme 4	Hospital
Programme 5	Nursing home
Programme 6	Hotel
Programme 7	Sports centre / Swimming pool
Programme 8	Convalescent home

* Increased risk of scalding during thermal disinfection cycle; by default sunday from 00:00 to 03:00.

QWT-04

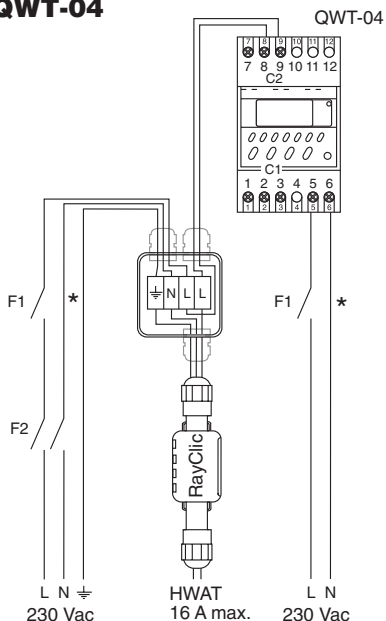

1. Electrical connection: See diagram

2. Programming

If you only operate the system with the timer QWT-04, you must change the programming of the timer.

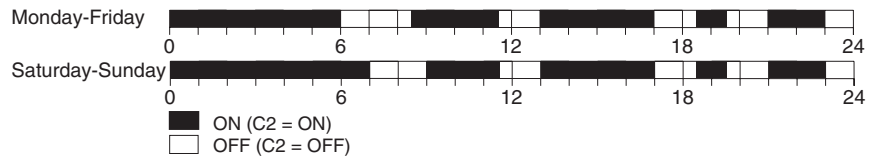

Important note:

Summer/winter settings must be programmed manually.

F1 = Circuit-breaker (C type) 16 A max

F2 = rcd 30 mA

* = Double-pole electrical protection may be needed for local circumstances, standards and regulations

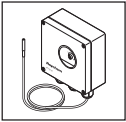

Wiring diagram for thermostat AT-TS-13 or AT-TS-14

AT-TS-13/14 direct

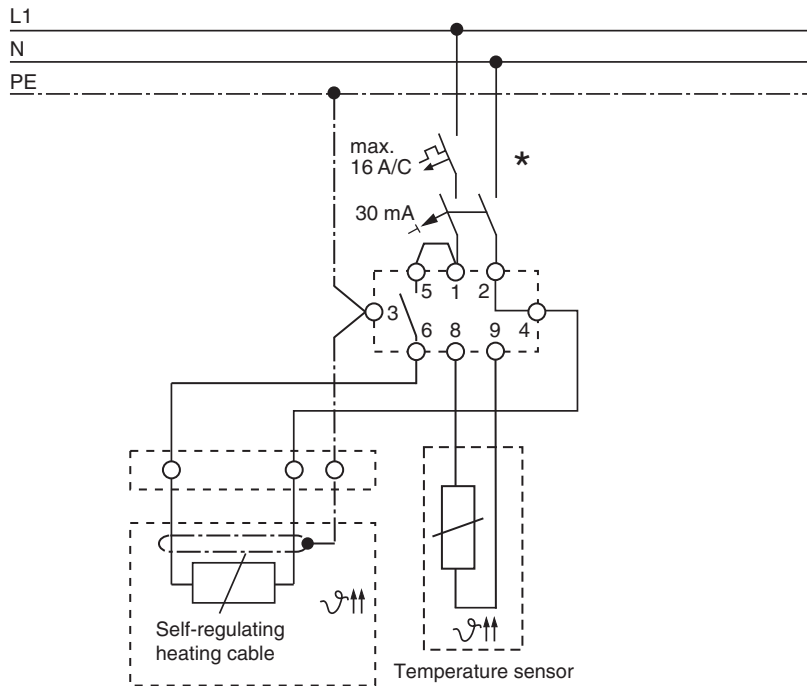

AT-TS-13/14 with contactor

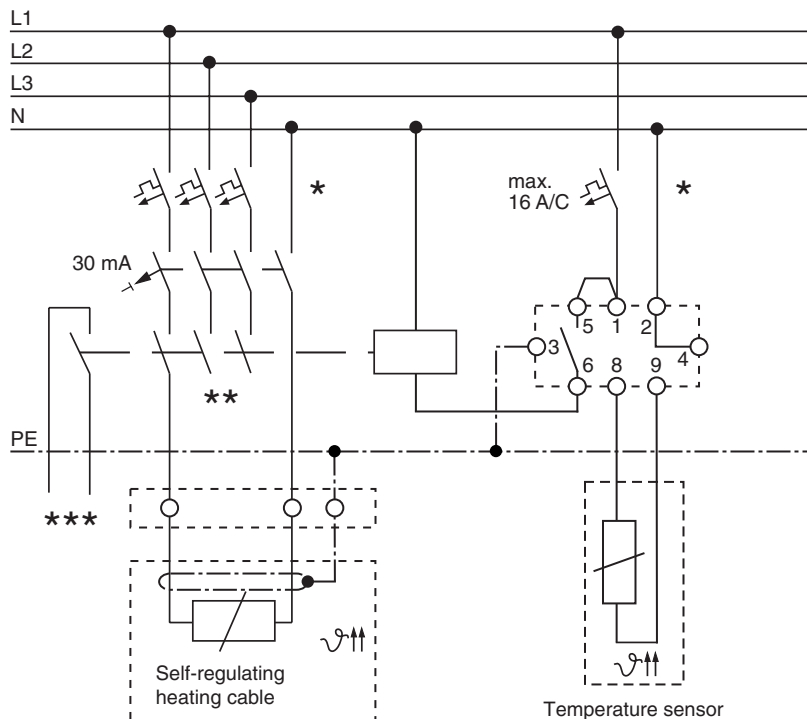

- * Two- or four-pole electrical protection by circuit-breaker may be needed for local circumstances, standards and regulations
- ** Depending on the application, one- or three-pole circuit-breakers or contactors may be used
- *** Optional: Potential-free circuit-breaker for connection to the BMS

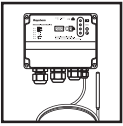

Wiring diagram for RAYSTAT-CONTROL-10.

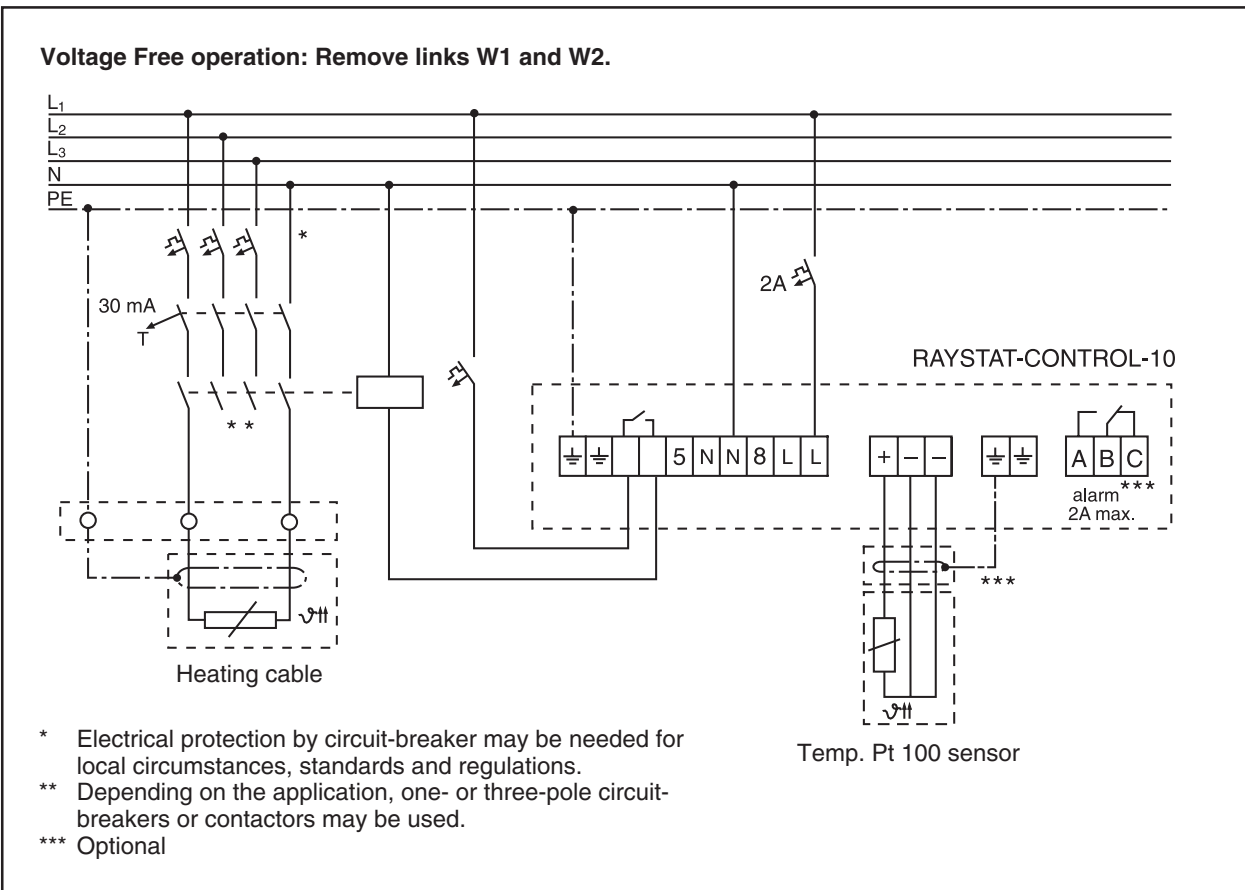
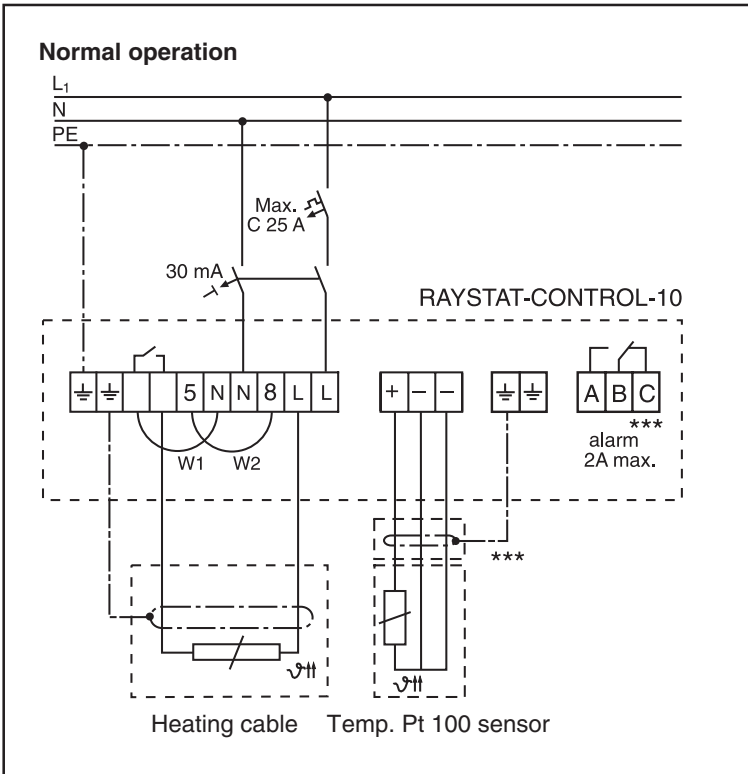

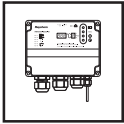

Wiring diagram for RAYSTAT-ECO-10.

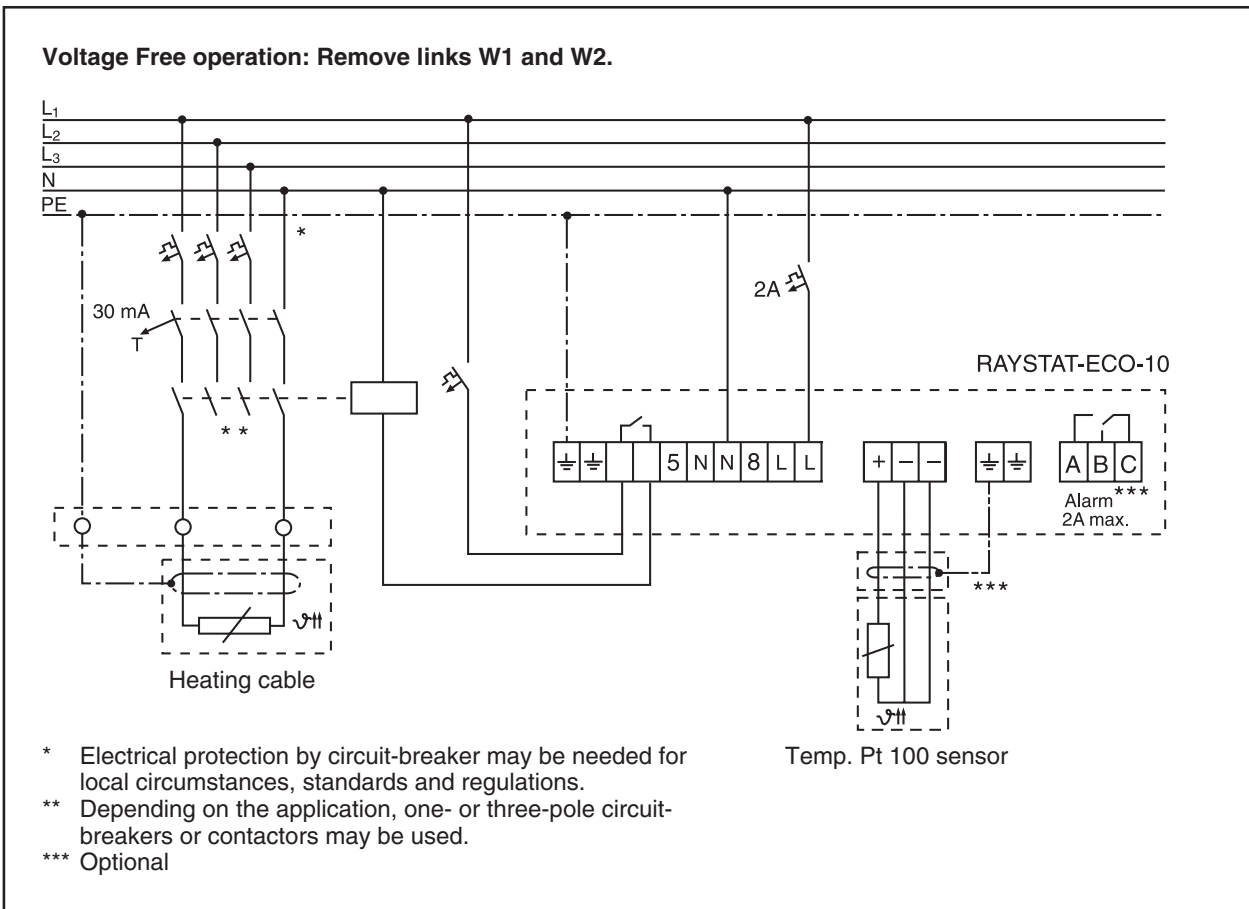
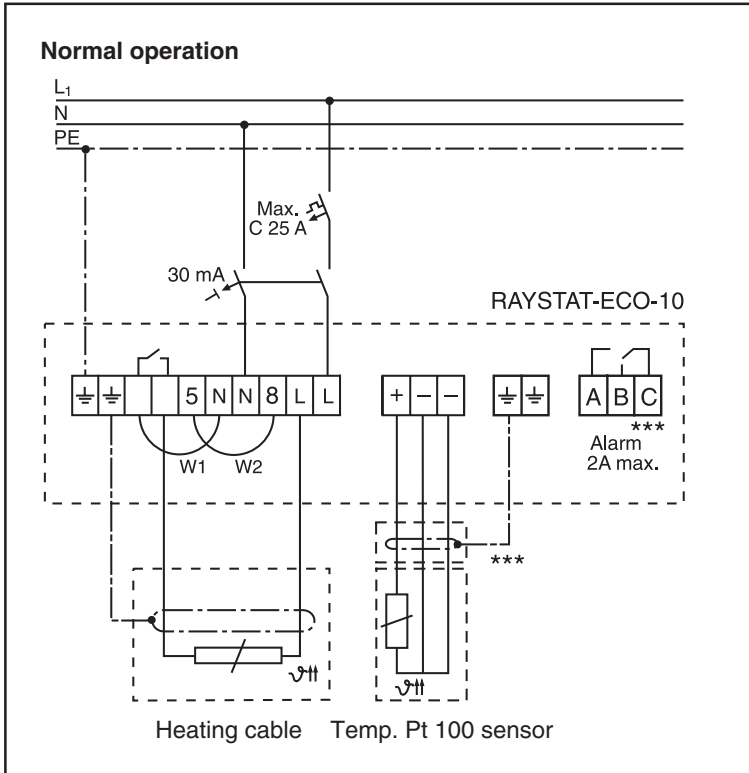

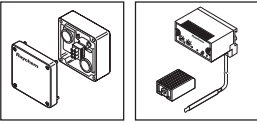

Wiring diagram for HTS-D and EMDR-1-01

HTS-D direct

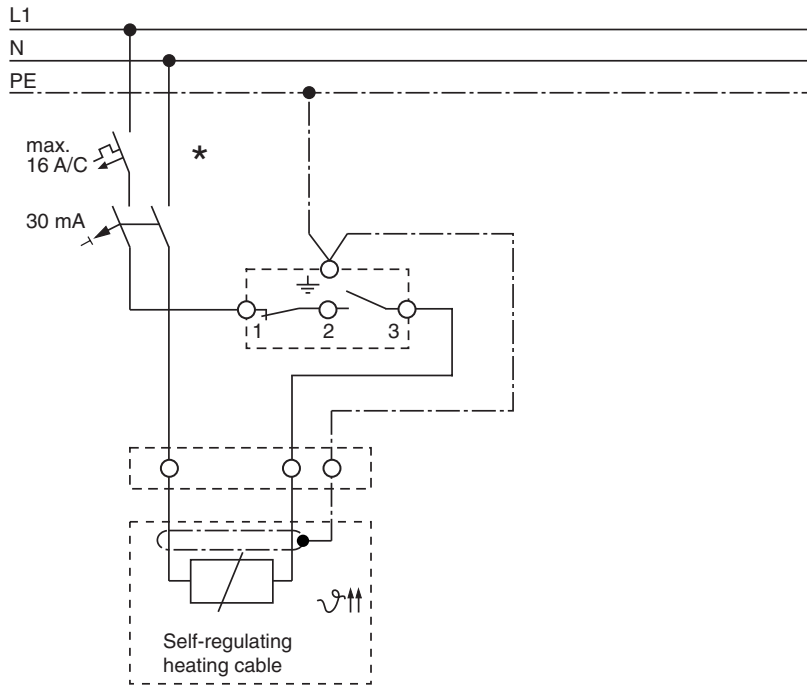

EMDR-1-01 with contactor

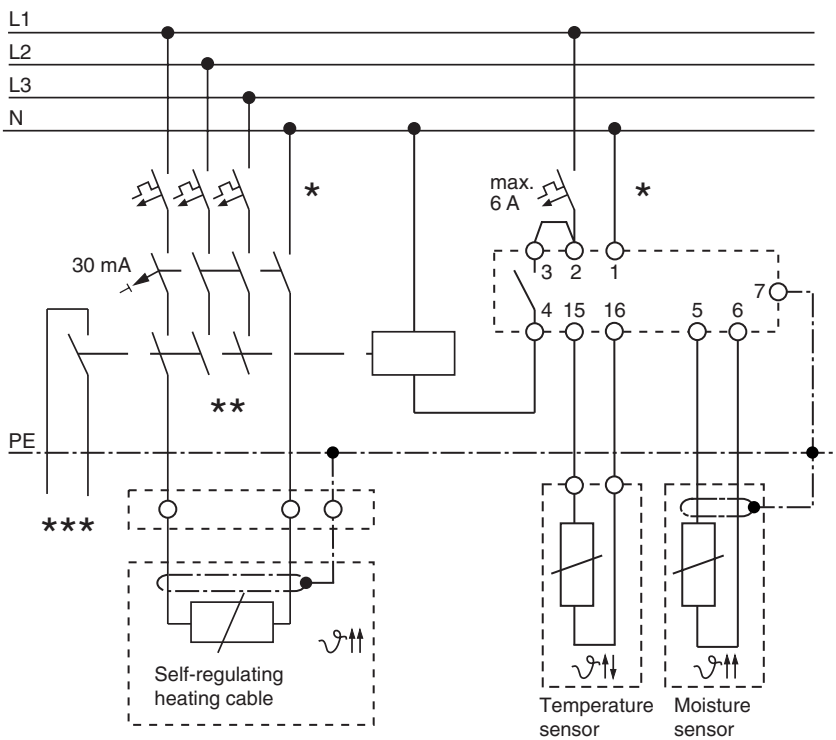

* Two- or four-pole electrical protection by circuit-breaker may be needed for local circumstances, standards and regulations

** Depending on the application, one- or three-pole circuit-breakers or contactors may be used

*** Optional: Potential-free circuit-breaker for connection to the BMS

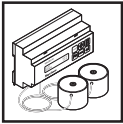

Wiring diagram for VIA-DU-10

VIA-DU-10 with contactor

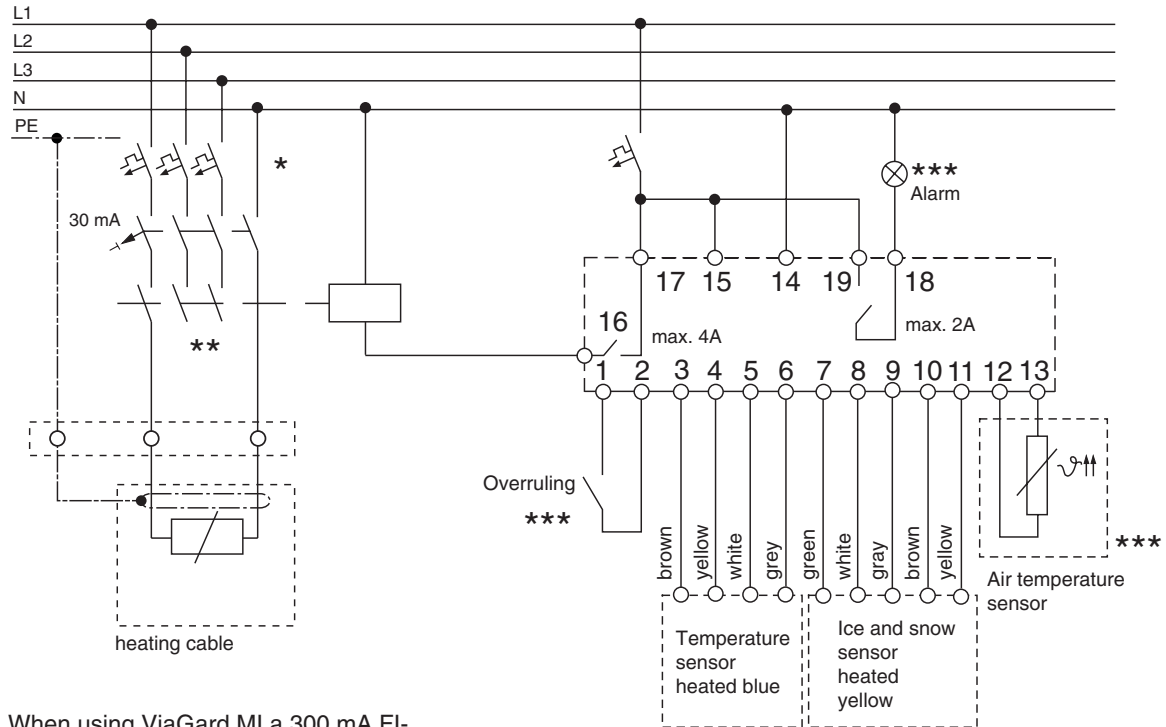

When using ViaGard MI a 300 mA FI-safety switch should be used.

- * Local values, standards and rules require two- or four-pole switching using a electrical protection
- ** Depending on the application, both one- and three-pole circuit breakers of contactors are possible.
- *** Optional and can be activated in a BMS.

Air temperature sensor will be needed only if in menu sleet precaution the parameter "local detection" has been selected. When weather forecast has been selected you have to connect the voltfree contacts of additional device to these terminals.

Checklist for problem-free installation and safe operation

Typical installation schedule for the HWAT-Plus system

General order of events:

- The HWAT-Plus system is designed and the installation planned.
- The pipework is pressure tested or otherwise checked for leaks.
- The HWAT cable is tested and then installed on the designated pipes.
- The HWAT-Plus components are installed and each circuit is tested.
- The correct thermal insulation is applied, without delay, labelled and system test repeated.
- The supply voltage cables and circuit breakers are installed to each HWAT-Plus circuit.
- The HWAT-Plus system is commissioned (see "System start-up" below).

Circuit protection, testing and operation for all systems

Circuit protection

- Supply voltage 230 Vac, 50 Hz
- The required protective measures of the relevant regulations must be complied with.
- C type circuit-breaker (anti-surge fuse)
- Residual current device (rcd 30 mA) required. Maximum approx. 500 m of Raychem self-regulating heating cable can be monitored per rcd.

Testing

- Visual inspection for damage and fault-free installation of the accessories
- Proper installation of the system
- Heating cable affixed to all necessary pipes
- No mechanical damage to heating cable (e.g. cuts, cracks, etc.)
- No thermal damage
- Proper connection of all components including power supplies
- Insulation resistance measurement when heating cable is received and before and after installation of the thermal insulation. The test voltage should be 2500 Vac, but it must not be lower than 500 Vac. The insulation resistance, irrespective of the cable length, must not be less than 10 MΩ. If the resistance falls below this value, the source of the fault must be investigated, eliminated, and re-tested.
 - Measurement A: Phase and neutral to the braid
 - Measurement B: Braid to the pipework
- After switching on, the cable ends must be warm after 5 to 10 minutes.

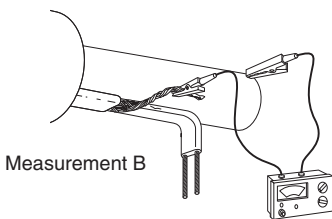
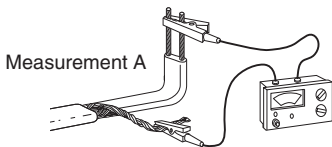

Instructions for the placing of the heat insulation

- For problem-free operation of the self-regulating heating cables, the material quality and thickness of the thermal insulation are in accordance with the design parameters, and this insulation must be installed correctly.
- All the parts of the pipework, including valves, wall transit points, etc. must be fully insulated.

Operation

System start-up

- 1) For small installations, turn on the circuit breakers and preferably leave the system overnight for the water to warm up and stabilise.
- 2) For bigger installations or for a faster start-up, first turn on the main water heater and open the outlet/tap at the end of the pipework run until the water feels warm and then turn on the circuit breakers.

If the piping system is closed, such as by pressure-reducing valves or isolation valves, you must provide some method of pressure relief to allow for thermal expansion of the water during heat-up.
- Under normal operating conditions, the heating cables are maintenance-free. Raychem recommends that the insulation resistance should be checked periodically and compared with the original values. If the reading falls below the minimum value (10 Megohms) determine the cause and rectify before re-use.
- The specified maximum ambient and operating temperatures should not be exceeded.
- In the event of repair to the pipework, the heating cable must be protected against damage. Correct functioning of the electrical protection system should be maintained. To prevent shock or personal injury, turn off the power at the circuit breaker before testing or working on the heating cable or piping.

- Following the completion of the repair work, the circuit should once again be tested (see above).
- All the important parts of the controls, thermostats, etc. must be checked for correct operation once a year, normally in the autumn.
- The maintenance temperature of HWAT-Plus should be 5°C to 10°C below the hot water temperature in the boiler.

Standard assembly times

The actual assembly times achieved may deviate according to the conditions on site.

Pipework

Assembly of heating cable on pipes including fastening, standard installation:	25 m/h
--	--------

RayClic connection system

(electrical connection)

RayClic-CE-02	2 min/pc.
RayClic-S-02/RayClic-PS-02	4 min/pc.
RayClic-T-02/RayClic-PT-02	6 min/pc.
RayClic-X-02	8 min/pc.
RayClic-E-02	1 min/pc.

Heat-shrink connection system

(electrical connection)

C16-29	15 min/pc.
E-06	5 min/pc.
CE16-05	20 min/pc.











Other

Testing, visual inspection, insulation resistance measurement (2x)	10 min/heating circuit
Connecting the heating circuit in the switch box	10 min/heating circuit

Trouble shooting guide

Fault	Possible causes	Measures
Circuit-breaker trips:	Circuit-breaker wrong type: e.g. type B instead of C:	Set to C Type
	Circuit-breaker undersized	If the power supply cable permits, install a larger circuit-breaker
	Circuit too long	Split the circuit on 2 circuit-breakers
	Short-circuit/earth fault	Eliminate short-circuit/earth fault (cable ends should not be twisted)
	Circuit-breaker faulty	Replace faulty circuit-breaker
	No end seal	Install end seal
	Conductor (or cable) twisted	Untwist and install end seal
RCD residual current device trips:	More than 500 m of frost protection heating cable installed per rcd	Install additional rcd residual current device
	Earth fault at connection or in end seal	Rectify earth fault
	Cable damaged	Replace cable where damaged
	Moisture in the junction box	Eliminate moisture
Pipeline does not become warm - Heating cable cold:	Circuit-breaker has tripped	See section circuit-breaker
	Residual current device has tripped	See section residual current device
	No mains voltage	Switch on
	Cable or RayClic cold end not connected	Connect cable or RayClic
	Cable not inserted correctly in RayClic	Insert cable according to RayClic installation instructions (fully insert cable)
Water temperature is not maintained but the cable gives high output:	No insulation	Insulation according to tables in design guides
	Insulation thickness too low	Insulation according to tables in design guides
	Insulation wet	Dry insulation
	Cold water is running from the boiler	Test boiler temperature
	Cold water is pumping through mixer tap into the hot water pipe	Test the mixer tap
	Insulation according to tables in design guides	Insulation according to tables in design guides

Technical data - Choice of accessories

	HWAT-Plus			WinterGard			IceStop	ViaGard	8BTV-2-CT	AutoSol
Cable type	HWAT-L	HWAT-M	HWAT-R	FS-A-2X	FS-B-2X	FS-C-2X	GM-2X	EM2-XR	8BTV-2-CT	5LC2-CT
Colour										
Nominal voltage	230 Vac	230 Vac	230 Vac	230 Vac	230 Vac	230 Vac	230 Vac	230 Vac	230 Vac	230 Vac
Nominal power output (*on insulated metal pipes)	7 W/m* at 45°C	9 W/m* at 55°C	12 W/m* at 70°C	10 W/m* at 5°C	26 W/m* at 5°C	31 W/m at 5°C, 22 W/m at 40°C	36 W/m in ice and 18 W/m in air at 0°C	300 W/m ² (90 W/m) at 0°C in concrete	18 W/m in air at 0°C 36 W/m in ice at 0°C	15 W/m at 25°C in floor screed
C-type circuit-breaker according to selected kit	max. 20 A	max. 20 A	max. 20 A	max. 16 A	max. 16 A	max. 16 A	max. 20 A	max. 50 A	max. 20 A	max. 16 A
Max. circuit length	180 m 20 A	100 m 20 A	100 m 20 A	150 m 16 A	105 m 16 A	90 m 16 A	80 m 20 A	85 m 50 A	80 m 20 A	100 m 10 A
Min. bending radius	10 mm	10 mm	10 mm	10 mm	10 mm	10 mm	10 mm	50 mm	12,7 mm (at 20°C)	25 mm (at 20°C)
Max. continous exposure temperature	65°C	65°C	85°C	65°C	65°C	95°C	65°C	100°C	65°C	65°C
Max. exposure temperature (power-on condition – 800 h. cumulative)	85°C	85°C	90°C	85°C	85°C	95°C	85°C	110°C	85°C	85°C
Max. dimensions in mm (W x H)	13.8 x 6.8	13.7 x 7.6	16.1 x 6.7	13.7 x 6.2	13.7 x 6.2	12.7 x 5.3	13.7 x 6.2	18.9 x 9.5	16.1 x 6.2	8.5 x 5.8
Weight	0.12 kg/m	0.12 kg/m	0.14 kg/m	0.13 kg/m	0.13 kg/m	0.13 kg/m	0.13 kg/m	0.27 kg/m	0.13 kg/m	0.10 kg/m
Approvals	BS / ÖVE / VDE / SEV / CSTB / SVGW / DVGW									
Control units	QWT-04	HWAT-ECO	HWAT-ECO	AT-TS-13 AT-TS-14 R-CONTROL R-ECO	AT-TS-13 AT-TS-14 R-CONTROL R-ECO	AT-TS-13 AT-TS-14 R-CONTROL	EMDR-1-01 HTS-D	VIA-DU-10	–	ASOL-T-02

Connection system

Junction box	–	–	–	–	–	JB16-02	–	VIA-JB1	JB16-02	–
Connection kit	RayClic	RayClic	RayClic	RayClic	RayClic	CE16-05	RayClic	VIA-CE1	CE16-29 E-06	ASOL-CE-01
Support bracket	included in the kit	included in the kit	included in the kit	included in the kit	included in the kit	JB-SB-08	included in the kit	–	JB-SB-08	–

Raychem

Your competent and experienced representatives

Associate Engineering

29 Downshire Road
Belfast BT3 9JL
Tel: 02890 815826
Fax: 02890 815828

John Hurlstone & Partners

Tel: 01204 888330
Fax: 01204 888331
Mark Taylor
Mob: 07966 379626
Ken O'Donoughue
Mob: 07976 613587

Harber Technical Services

Millgate House
Windsor Road
Bray
Berkshire SL6 2DW
Tel: 01628 624988
Fax: 01628 639921
Bob Berett
Mob: 07836 601279

Harber Technical Services

Millgate House
Windsor Road
Bray
Berkshire SL6 2DW
Tel: 01628 624988
Fax: 01628 639921
Rob Boland
Mob: 07710 474936

George Watson Technical Sales

40 Rosslyn Avenue
Rutherglen
Glasgow G73 3HA
Tel: 0141 6430816
Fax: 0141 6430816
Mob: 07860 766460

Embleton Environmental Products

Gear House
Saltmeadows Road
Gateshead NE8 3AH
Tel.: 0191 490 1155
Fax: 0191 478 5915
Mob: 07860 828317

John Hurlstone & Partners

Lee Flintoft
Tel: 01423 529666
Fax: 01423 529666
Mob: 07971 479642

John Hurlstone & Partners

Tel: 0121 3584363
Fax: 0121 3584393
Dave Shakeshaft
Mob: 07976 950044
Dave Tickle
Mob: 07976 950045

Astec Ltd

Riverside Road
Gorleston-on-Sea
Great Yarmouth
Norfolk NR31 6PX
Tel: 01493 441040
Fax: 01493 441060
Mob: 07768 078749

Techform Developments

36 Blossom Way
Hillingdon
Middlesex UB10 9LN
Tel: 01895 235831
Fax: 01895 258268
Mob: 07836 251379



For Raychem heating cables there is a guarantee agreement between the ZVSHK and Raychem GmbH



Member of the European Radiant Floor Heating Association e.v.

Mitglied im



Bundesverband
Flächenheizungen e.V.



Raychem products satisfy the requirements of the relevant European Directives.

www.raychemhts.com

This documentation was supplied to you by:

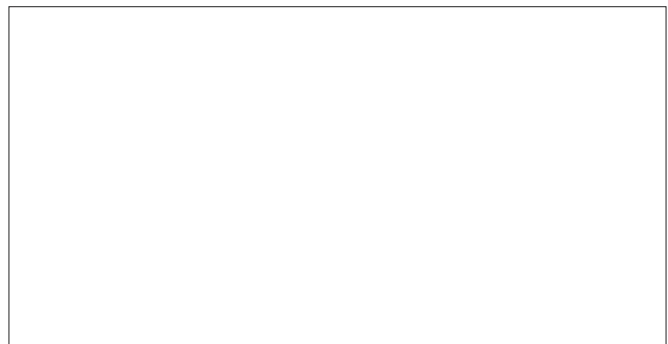

Raychem HTS, HWAT-Plus, WinterGard, RayClic, IceStop and ViaGard are registered trademarks of Tyco Electronics.

All of the above information, including illustrations, is believed to be reliable. Users however, should independently evaluate the suitability of each product for their application. Raychem HTS makes no warranties as to the accuracy or completeness of the information and disclaims any liability regarding its use. Raychem HTS's only obligations are those in the Standard Terms and Conditions of Sale for this product and in no case will Raychem HTS be liable for any incidental, indirect or consequential damages arising from the sale, resale, use or misuse of the product. Raychem HTS Specifications are subject to change without notice. In addition Raychem HTS reserves the right to make changes in materials or processing, without notification to the Buyer, which do not affect compliance with any applicable specification.

tyco

Flow Control

Raychem HTS

Raychem HTS
Faraday Road
Dorcan, Wiltshire SN3 5HH
Tel.: 0800 169 6812
Fax: 01793 572629