

**Agilent U2802A  
31-Channel  
Thermocouple Input  
Device**

**User's Guide**



**Agilent Technologies**

# Notices

© Agilent Technologies, Inc. 2009

No part of this manual may be reproduced in any form or by any means (including electronic storage and retrieval or translation into a foreign language) without prior agreement and written consent from Agilent Technologies, Inc. as governed by United States and international copyright laws.

## Manual Part Number

U2802-90003

## Edition

Second Edition, September 7, 2009

Agilent Technologies, Inc.  
3501 Stevens Creek Blvd.  
Santa Clara, CA 95052 USA

## Warranty

**The material contained in this document is provided “as is,” and is subject to being changed, without notice, in future editions. Further, to the maximum extent permitted by applicable law, Agilent disclaims all warranties, either express or implied, with regard to this manual and any information contained herein, including but not limited to the implied warranties of merchantability and fitness for a particular purpose. Agilent shall not be liable for errors or for incidental or consequential damages in connection with the furnishing, use, or performance of this document or of any information contained herein. Should Agilent and the user have a separate written agreement with warranty terms covering the material in this document that conflict with these terms, the warranty terms in the separate agreement shall control.**

## Technology Licenses

The hardware and/or software described in this document are furnished under a license and may be used or copied only in accordance with the terms of such license.

## Restricted Rights Legend

U.S. Government Restricted Rights. Software and technical data rights granted to the federal government include only those rights customarily provided to end user customers. Agilent provides this customary commercial license in Software and technical data pursuant to FAR 12.211 (Technical Data) and 12.212 (Computer Software) and, for the Department of Defense, DFARS 252.227-7015 (Technical Data - Commercial Items) and DFARS 227.7202-3 (Rights in Commercial Computer Software or Computer Software Documentation).

## Safety Notices

### CAUTION

A **CAUTION** notice denotes a hazard. It calls attention to an operating procedure, practice, or the like that, if not correctly performed or adhered to, could result in damage to the product or loss of important data. Do not proceed beyond a **CAUTION** notice until the indicated conditions are fully understood and met.

---

### WARNING

A **WARNING** notice denotes a hazard. It calls attention to an operating procedure, practice, or the like that, if not correctly performed or adhered to, could result in personal injury or death. Do not proceed beyond a **WARNING** notice until the indicated conditions are fully understood and met.

---









## Safety Information

The following general safety precautions must be observed during all phases of this instrument. Failure to comply with these precautions or with specific warnings elsewhere in this manual violates safety standards of design, manufacture, and intended use of the instrument. Agilent Technologies, Inc. assumes no liability for the customer's failure to comply with these requirements.







### Safety Symbols

The following symbols indicate that precautions must be taken to maintain safe operation of the instrument.

---

	Direct current
	Alternating current
	Both direct and alternating current
	Three-phase alternating current
	Earth (ground) terminal
	Protective conductor terminal
	Frame or chassis terminal
	Equipotentiality
	On (Supply)

---

	Off (Supply)
	Equipment protected throughout by double insulation or reinforced insulation
	Caution, risk of electric shock
	Caution, hot surface
	Caution, risk of danger (See note.)
	In position of a bi-stable push control
	Out position of a bi-stable push control

## Regulatory Markings

---



The CE mark is a registered trademark of the European community. This CE mark shows that the product complies with all the relevant European legal directive.

---

ICES/NMB-001

ICES/NMB-001 indicates that this ISM device complies with Canadian ICES-001.

---



The CSA mark is a registered trademark of the Canadian Standards Association. A CSA mark with the indicators "C" and "US" means that the product is certified for both the U.S. and Canadian markets, to the applicable American and Canadian standards.

---



The C-tick mark is a registered trademark of the Spectrum Management Agency of Australia. This signifies compliance with the Australian EMC Framework regulations under the terms of the Radio Communications Act of 1992.

---



This product complies with the (2002/96/EC) marking equipment. The affixed product label indicates that you must not discard this electrical/electronic product in domestic household waste.

---

## General Safety Information

### WARNING

- Do not use the device if it is damaged. Before you use the device, inspect the case. Look for cracks or missing plastic. Do not operate the device around explosive gas, vapor or dust.
  - Do not apply more than the rated voltage (as marked on the device) between terminals, or between terminal and external ground.
  - Always use the device with the cables provided.
  - Observe all markings on the device before connecting to the device.
  - Turn off the device and application system power before connecting to the I/O terminals.
  - When servicing the device, use only specified replacement parts.
  - Do not operate the device with the removable cover removed or loosened.
  - Do not connect any cables and terminal block prior to performing self-test process.
  - Use only the power adapter supplied by the manufacturer to avoid any unexpected hazards.
- 

### CAUTION

- Do not load the input and output terminals above the specified operating limits. Input terminals should not exceed  $\pm 10$  V with respect to the module ground. Applying excessive voltage or overloading the device will cause irreversible damage to the circuitry.
  - Applying excessive voltage or overloading the input terminal will damage the device permanently.
  - If the device is used in a manner not specified by the manufacturer, the protection provided by the device may be impaired.
  - The U2802A can only be used with U2355A or U2356A DAQs and used with the SCSI cables provided.
  - Always use dry cloth to clean the device. Do not use ethyl alcohol or any other volatile liquid to clean the device.
  - Do not permit any blockage of the ventilation holes of the device.
-

## Waste Electrical and Electronic Equipment (WEEE) Directive 2002/96/EC

This instrument complies with the WEEE Directive (2002/96/EC) marking requirement. This affixed product label indicates that you must not discard this electrical/electronic product in domestic household waste.

Product Category:

With reference to the equipment types in the WEEE directive Annex 1, this instrument is classified as a “Monitoring and Control Instrument” product.

The affixed product label is shown as below:

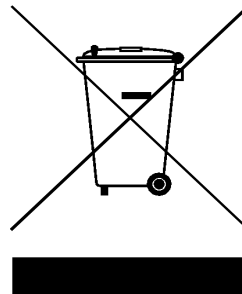

### **Do not dispose in domestic household waste**

To return this unwanted instrument, contact your nearest Agilent office, or visit:

<http://www.agilent.com/environment/product>

for more information.

## Environmental Conditions

The table below shows the general environmental requirements for the product.

<b>Environmental Conditions</b>	<b>Requirements</b>
Temperature	Operating temperature from 0 °C to +55 °C
Humidity	Relative humidity at 50% to 85% RH (Non-condensing)
Altitude	Altitude up to 2000 meters
Storage compliance	-40 °C to +70 °C

## In This Guide...

### **1 Getting Started**

This chapter introduces the new Agilent U2802A 31-channel thermocouple input device and provides quick start information. It also provides product outlook, installation configuration and troubleshooting guide.

### **2 Features and Functions**

This chapter contains details of the product features, applications, system overview and theory of operation. From this chapter, you will understand the Agilent U2802A 31-channel thermocouple input system overview and functionality of this device.

### **3 Pin Configurations and Assignments**

This chapter described the Agilent U2802A 31-channel thermocouple input device pin configurations and connector pinout for user's reference.

### **4 Product Specifications**

This chapter specifies the environmental conditions, characteristics, and specifications of the Agilent U2802A 31-channel thermocouple input device. It also covers the system accuracy, typical performance and guidelines to make accurate temperature measurements.

### **5 Calibration**

This chapter contains the calibration information and factory restore calibration procedure for the Agilent U2802A 31-channel thermocouple input device.

 <b>Agilent Technologies</b>	<b>DECLARATION OF CONFORMITY</b> According to EN ISO/IEC 17050-1:2004	
---	--	---

**Manufacturer's Name:** Agilent Technologies Microwave Products (M) Sdn. Bhd  
**Manufacturer's Address:** Bayan Lepas Free Industrial Zone,  
 11900, Bayan Lepas, Penang, Malaysia

**Declares under sole responsibility that the product as originally delivered:**

**Product Name:** 31-Channel Thermocouple Input Device  
**Models Number:** U2802A  
**Product Options:** This declaration covers all options of the above product(s)

**complies with the essential requirements of the following applicable European Directives, and carries the CE marking accordingly:**

Low Voltage Directive (2006/95/EC)  
 EMC Directive (2004/108/EC)

**and conforms with the following product standards:**

EMC	Standard	Limit
	IEC 61326:2002 / EN 61326:1997+A1:1998+A2:2001+A3:2003	
	CISPR 11:1990 / EN55011:1990	Class A Group 1
	IEC 61000-4-2:1995 / EN 61000-4-2:1995	4 kV CD, 8 kV AD
	IEC 61000-4-3:1995 / EN 61000-4-3:1996	3 V/m, 80-1000 MHz
	IEC 61000-4-4:1995 / EN 61000-4-4:1995	0.5 kV signal lines, 1 kV power lines
	IEC 61000-4-5:1995 / EN 61000-4-5:1995	0.5 kV line-line, 1 kV line-ground
	IEC 61000-4-6:1996 / EN 61000-4-6:1996	3 V, 0.15-80 MHz
	IEC 61000-4-11:1994 / EN 61000-4-11:1994	1 cycle / 100%

Canada: ICES-001:2004  
 Australia/New Zealand: AS/NZS CISPR11:2004

The product was tested in a typical configuration with Agilent Technologies test systems.

**Safety** IEC 61010-1:2001 / EN 61010-1:2001  
 Canada: CAN/CSA-C22.2 No. 61010-1-04  
 USA: ANSI/UL 61010-1:2004

**This DoC applies to above-listed products placed on the EU market after:**

20-November-2007  
 \_\_\_\_\_  
 Date

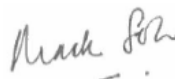
  
 \_\_\_\_\_  
**Mack Soh**  
 Quality Manager

For further information, please contact your local Agilent Technologies sales office, agent or distributor, or Agilent Technologies Deutschland GmbH, Herrenberger Straße 130, 71034 Böblingen, Germany.

## Product Regulations

### EMC

IEC 61326-1:2002 / EN 61326-1:1997+A1:1998+A2:2001+A3:2003

CISPR 11:1990 / EN 55011:1990 – Group 1 Class A

IEC 61000-4-2:1995 / EN 61000-4-2:1995 (ESD 4kV CD, 8kV AD)

IEC 61000-4-3:1995 / EN 61000-4-3:1996 (3V/m, 80% AM)

IEC 61000-4-4:1995 / EN 61000-4-4:1995 (EFT 0.5kV line-line, 1kV line-earth)

IEC 61000-4-5:1995 / EN 61000-4-5:1995 (Surge 0.5kV line-line, 1kV line-earth)

IEC 61000-4-6:1996 / EN 61000-4-6:1996 (3V, 0.15~80 MHz, 80% AM, power line)

IEC 61000-4-11:1994 / EN 61000-4-11:1994 (Dips 1 cycle, 100%)

Canada: ICES-001:2004

Australia/New Zealand: AS/NZS CISPR11:2004

### Performance Criteria

A

A

B

B

A

B

**Safety** IEC 61010-1:2001 / EN 61010-1:2001

Canada: CAN/CSA-C22.2 No. 61010-1-04

USA: ANSI/UL 61010-1:2004

### Additional Information:

The product herewith complies with the essential requirements of the Low Voltage Directive 2006/95/EC and the EMC Directive (2004/108/EC) and carries the CE Marking accordingly (European Union).

### <sup>1</sup>Performance Criteria:

A Pass - Normal operation, no effect.

B Pass - Temporary degradation, self recoverable.

C Pass - Temporary degradation, operator intervention required.

D Fail - Not recoverable, component damage.

N/A – Not applicable due to the product is a battery operated device

### Notes:

#### Regulatory Information for Canada

ICES/NMB-001:2004

This ISM device complies with Canadian ICES-001.

Cet appareil ISM est conforme à la norme NMB-001 du Canada.

#### Regulatory Information for Australia/New Zealand

This ISM device complies with Australian/New Zealand AS/NZS CISPR11:2004

 N10149



# Contents

Notices	II
Safety Information	III
Environmental Conditions	VIII
In This Guide...	IX
Declaration of Conformity	X

## 1 Getting Started

Introduction to Agilent U2802A 31-Channel Thermocouple Input	2
Product Overview	3
Standard Purchase Items Checklist	6
Installations and Configurations	7
IVI-COM Drivers	19

## 2 Features and Functions

Features	26
Applications	27
System Overview	28
Theory of Operation	29

## 3 Pin Configurations and Assignments

Pin Configurations	38
Connector Pinout	44

## 4 Product Specifications

General Specifications	48
Product Characteristics	49
System Accuracy Specifications	51
System Typical Performance	57
Making Accurate Temperature Measurements	59

## **5 Calibration**

Calibration Information 62

Zeroing Function 62

Restore Factory Calibration 63

## List of Figures

- Figure 1-1 U2802A installation flowchart 8
- Figure 2-1 System overview of U2802A with DAQ 28
- Figure 2-2 System functionality block diagram for U2802A 29
- Figure 2-3 Functional block diagram for U2802A 30
- Figure 2-4 Functional block diagram for thermocouple mode in U2802A 31
- Figure 2-5 Floating signal source configuration in U2802A 32
- Figure 2-6 Ground-referenced and differential signal sources configuration in U2802A 33
- Figure 3-1 U2802A pin assignment 38
- Figure 3-2 Connector 1 pin assignment for U2355A and U2356A 44
- Figure 3-3 Connector 2 pin assignment for U2355A and U2356A 45
- Figure 4-1 Thermoelectric characteristics for various thermocouple types 57
- Figure 4-2 U2802A measurement accuracy plot for various thermocouples type 58

## List of Tables

Table 4-1 U2802A measurement accuracy with U2355A or U2356A, at  $23\text{ }^{\circ}\text{C} \pm 5\text{ }^{\circ}\text{C}$ , with different number of averaging points. [51](#)

Table 4-2 U2802A measurement accuracy with U2355A, at 0 to  $18\text{ }^{\circ}\text{C}$  and 28 to  $45\text{ }^{\circ}\text{C}$ , with different number of averaging points. [52](#)

Table 4-3 U2802A measurement accuracy with U2356A, at 0 to  $18\text{ }^{\circ}\text{C}$  and 28 to  $45\text{ }^{\circ}\text{C}$ , with different number of averaging points. [53](#)

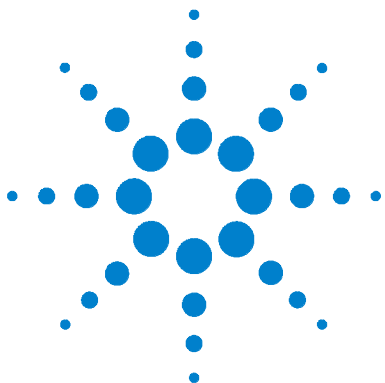

# 1 Getting Started

Introduction to Agilent U2802A 31-Channel Thermocouple Input	2
Product Overview	3
Product Outlook	3
Product Dimensions	5
Standard Purchase Items Checklist	6
Installations and Configurations	7
A. Check Your System Requirements	9
B. Check Your Pre-Installed IO Libraries Suite	10
C. Install the Agilent IO Libraries Suite Version 14.2 or Higher	11
D. Install the DAQ Hardware Driver	13
E. Install the Agilent Measurement Manager	13
F. Connect Your DAQ Device to the PC	17
G. Hardware Verification	17
H. Connect Your U2802A to DAQ	17
I. Launch Your Agilent Measurement Manager	18
IVI-COM Drivers	19

This chapter introduces the new Agilent U2802A 31-channel thermocouple input device and provides quick start information. It also provides product outlook, installation configuration and troubleshooting guide.



## Introduction to Agilent U2802A 31-Channel Thermocouple Input

The Agilent U2802A 31-channel thermocouple input is a thermocouple input device that functions to convert low input voltage signal ( $< \pm 100$  mV) from a thermocouple into an output voltage range suitable for data acquisition (DAQ) device ( $\pm 10$  V).



The Agilent U2802A thermocouple signal conditioner is to be used in conjunction with the U2355A or U2356A model DAQ to enable temperature measurements using thermocouples.

It works as a standalone device attached to a single DAQ. The U2802A thermocouple device is connected to the modular DAQ via SCSI cables. Agilent U2802A accepts eight standard thermocouple types defined in the NIST ITS-90 Thermocouple Database, which are Type B, E, J, K, N, R, S and T.

It is ideal for a broad variety of temperature and voltage measurement applications in education, industrial and scientific environments. The U2802A comes with an on-board EEPROM features. Hence, it allows user to store calibration data in volatile memory. Therefore, the U2802A is robust, cost-effective, and user friendly device.

For detailed product specifications, please refer to “General Specifications” on [page 48](#).

# Product Overview

## Product Outlook

### Top View

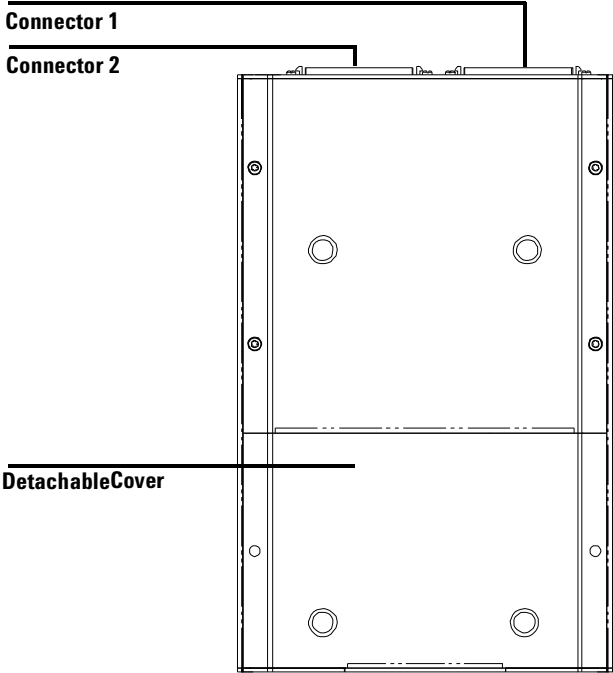

### Front View

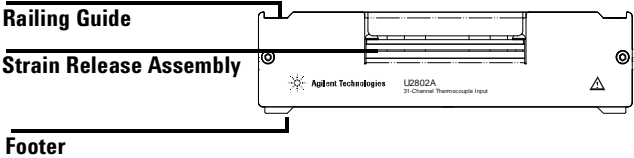

**Side View**

**Ventilation  
Holes**

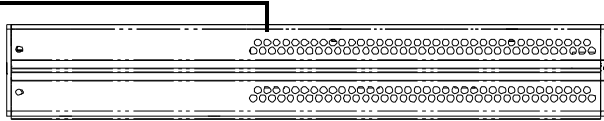

**Bottom View**

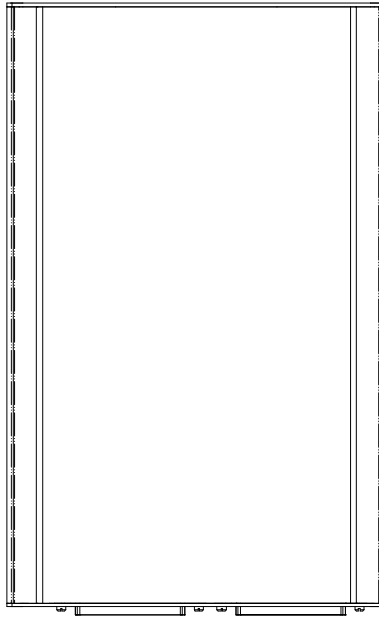

# Product Dimensions

## Top View

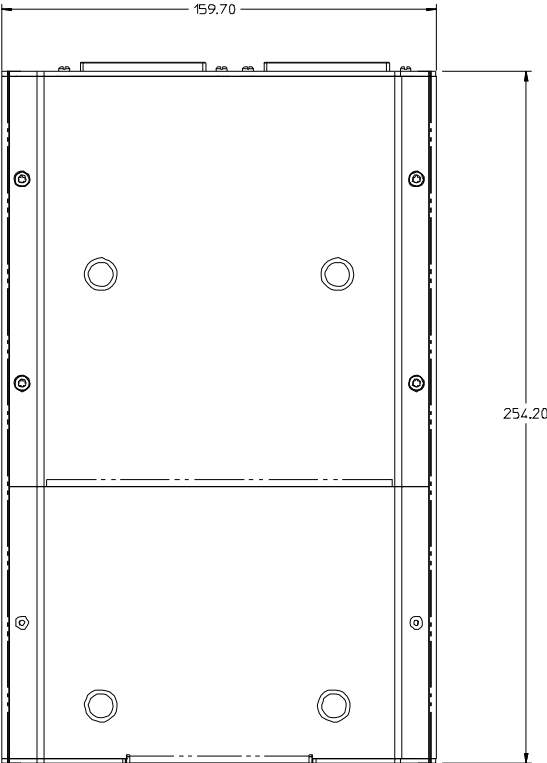

## Front View

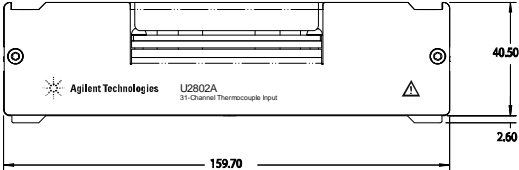

## Standard Purchase Items Checklist

Inspect and verify that you have all the following items upon standard purchase of U2802A 31-channel thermocouple input device. If there are missing items, contact the nearest Agilent Sales Office.

- ✓ Agilent U2802A 31-channel thermocouple input device
- ✓ Power supply splitter
- ✓ Two 68-pin SCSI cables (1 m)
- ✓ One J-type thermocouple
- ✓ Quick Start Guide
- ✓ Product Reference CD-ROM
- ✓ Agilent Automation-Ready CD (contains the Agilent IO Libraries Suite)
- ✓ Certificate of Calibration

## Installations and Configurations

The U2802A is used in conjunction with the U2355A or U2356A DAQ. If you are using the U2300A Series with the Agilent Measurement Manager, follow the step-by-step instructions as shown in the following flowchart.

### NOTE

- If you do not wish to specifically use the U2300A Series with the Agilent Measurement Manager software, and use the DAQ devices with Agilent VEE, LabVIEW or Microsoft Visual Studio only, you can skip steps E and I in the following flowchart.
  - You need to install IVI-COM driver before using the U2300A Series with Agilent VEE, LabVIEW or Microsoft Visual Studio.
  - If you have installed and currently using the U2300A Series, you may skip the initial steps and proceed to step H for U2802A Thermocouple Input installation in the following flowchart. Make sure Agilent Measurement Manager version 1.4 and above is installed before you proceed.
-

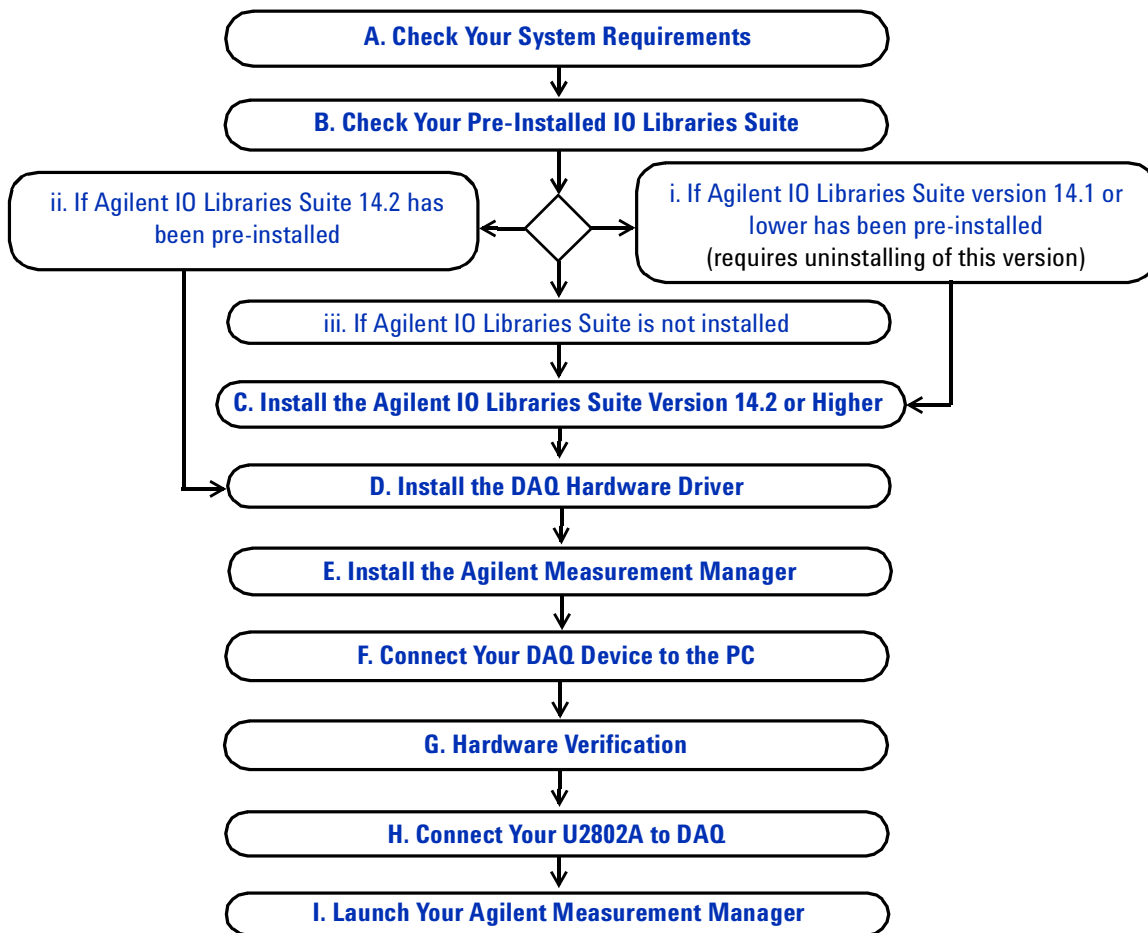

Figure 1-1 U2802A installation flowchart

## A. Check Your System Requirements

Before installing the Agilent Measurement Manager software and DAQ hardware driver, make sure your PC meets the following minimum system requirements for installation and data acquisition.

**Processor** 1.6 GHz Pentium IV or higher

**Operating system** One of the following Microsoft Windows versions: Windows XP Professional or Home Edition (Service Pack 1 or later), Windows 2000 Professional (Service Pack 4 or later)

**Browser** Microsoft Internet Explorer 5.01 or higher

**Available RAM** 512 MB or higher is recommended

**Hard disk space** 1 GB

**Prerequisite** Agilent IO Libraries Suite 14.2<sup>1</sup> or higher, Agilent T&M Toolkit 2.1 Runtime version<sup>2</sup>, Agilent T&M Toolkit Redistributable Package 2.1 patch<sup>2</sup>, Microsoft .NET Framework version 1.1 and 2.0<sup>2</sup>

1 Available on Agilent Automation-Ready CD.

2 Bundled with Agilent Measurement Manager application software installer.

## B. Check Your Pre-Installed IO Libraries Suite

To check the version of your pre-installed IO Libraries Suite follow the instructions below.

- 1 Right-click IO Control icon on your taskbar notification area and the context menu will appear as shown below. Select **About Agilent IO Control**.

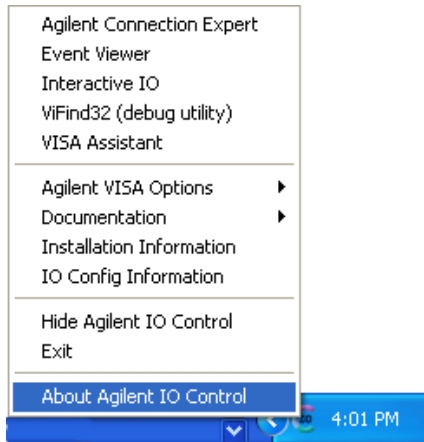

- 2 Agilent IO Control window will appear and the version of installed IO Libraries Suite will be displayed as shown below.

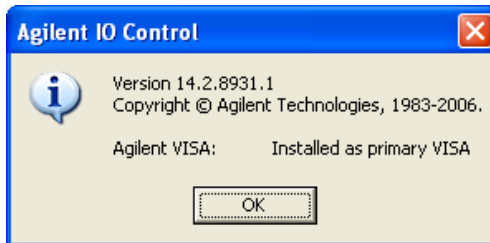

### NOTE

If the Agilent IO Control icon is not visible on the taskbar notification area it may indicate that,

- you do not have the Agilent IO Libraries installed, or
- you have hidden the Agilent IO Control icon from the taskbar notification area.

To activate the icon, go to **Start > All Programs > Agilent IO Libraries Suite > Utilities > IO Control**. You will now see the Agilent IO Control icon appear on your taskbar notification area.

**i. If Agilent IO Libraries Suite version 14.1 or lower has been pre-installed**

If you have Agilent IO Libraries Suite version 14.1 or lower installed on your PC, you are required to uninstall the IO Libraries Suite.

- 1 To perform uninstallation, go to **Start > Control Panel > Add or Remove Programs**. The Add or Remove Programs window will appear. Select Agilent IO Libraries Suite 14.1 or lower version.
- 2 Click **Change/Remove** and select **Remove** when the instructions on the screen prompted to proceed uninstalling the IO Libraries Suite version 14.1 or lower from your PC.
- 3 Proceed to **C. Install the Agilent IO Libraries Suite Version 14.2 or Higher**.

**ii. If Agilent IO Libraries Suite 14.2 has been pre-installed**

If you have the IO Libraries Suite 14.2 pre-installed on your PC, skip Step C and proceed to **D. Install the DAQ Hardware Driver**.

**iii. If Agilent IO Libraries Suite is not installed**

If you do not have IO Libraries Suite installed on your PC, go to **C. Install the Agilent IO Libraries Suite Version 14.2 or Higher**.

**C. Install the Agilent IO Libraries Suite Version 14.2 or Higher**

The Agilent IO Libraries Suite 14.2 is available in the *Agilent Automation-Ready CD* that comes with the standard purchase of Agilent U2300A Series USB Multifunction Data Acquisition Devices or U2802A 31-Channel Thermocouple Input.

**NOTE**

- If you do not have the *Agilent Automation-Ready CD*, obtain the Agilent IO Libraries Suite 14.2 or higher at <http://www.agilent.com/find/iolib>.
- Ensure that you do not have any USB DAQ device connected to your PC during installation of the Agilent IO Libraries Suite.

## 1 Getting Started

- 1 Disconnect any USB DAQ device that is connected to your PC and close all other applications on your PC.
- 2 Insert the *Agilent Automation-Ready CD* into your CD-ROM drive, and follow the instructions on your screen.
- 3 If the installation does not start automatically, go to **Start > Run** (on the Windows start menu) and type <drive>:\autorun\auto.exe where drive is your CD-ROM drive.
- 4 If you obtain the Agilent IO Libraries Suite from the web, save the self-extracting zip file (\*.exe) to any location on your hard disk.
- 5 Double-click the installation file to launch the installation.
- 6 Follow the instructions on your screen to proceed with the installation.
- 7 After the installation is completed, you will see the IO Control icon on the Windows taskbar notification area as shown below.



### NOTE

For detailed installation instructions, refer to the *Agilent IO Libraries Suite Getting Started Guide* at <http://www.agilent.com/find/iolib>.

## D. Install the DAQ Hardware Driver

### NOTE

Refer to *Agilent U2300A Series USB Multifunction Data Acquisition Devices User's Guide* for DAQ hardware driver installation procedure.

## E. Install the Agilent Measurement Manager

### NOTE

Make sure Agilent Measurement Manager version 1.4 and above is installed before U2802A is used.

- 1 Verify that you have the hardware driver installed. If not, close all other applications on your PC and insert the *Product Reference CD-ROM* into your CD-ROM drive.
- 2 Click **Measurement Manager** on the Agilent Modular Products Installation Menu to begin the installation.

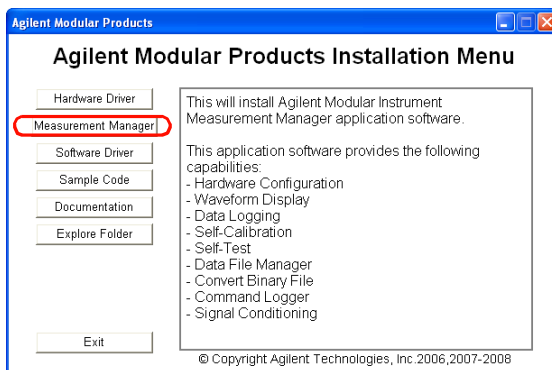

- 3 If the installation menu does not appear after a few seconds, go to **Start > Run** and type `<drive>:\Application\Modular Instruments Measurement Manager\setup.exe`, where `drive` is your CD-ROM drive.
- 4 Click **OK** to begin installation.

- 5 If you do not have the Agilent T&M Toolkit 2.1 Runtime version and/or Microsoft .NET Framework version 1.1 and 2.0 installed, the InstallShield Wizard software pre-requisite will appear as shown below.

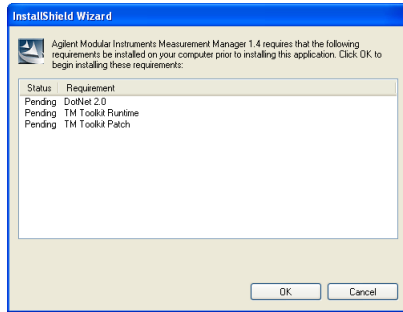

- 6 Click **OK** to begin installation of the listed missing software.
- 7 Once the above installation is completed, installation of the Agilent Measurement Manager software will proceed as normal
- 8 The Agilent Measurement Manager InstallShield Wizard dialog box will appear as shown below. Click **Next** to begin.

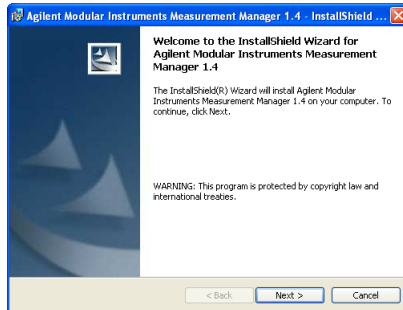

- 9 Read the License Agreement and select **I accept the terms in the License Agreement** to proceed. You may click **Print** to print a hardcopy of the Agilent License Terms for reference. Click **Next** to proceed.

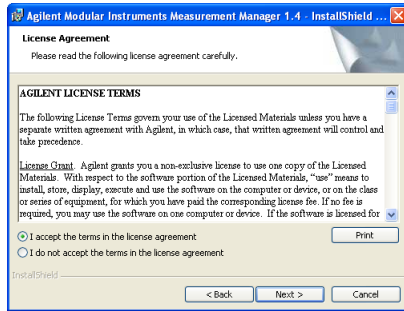

- 10 Fill in the Customer Information form, as shown below, accordingly and click **Next**.

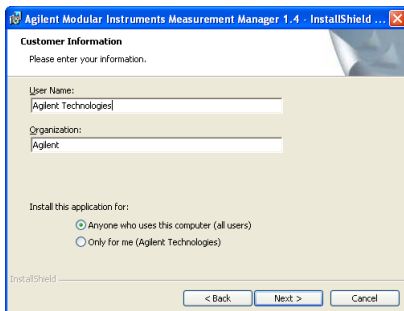

- 11 Click **Next** to install to the folder specified or click **Change** to install to a different folder.

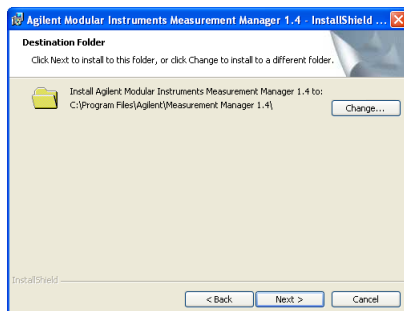

12 Click **Install** to begin the installation of Agilent Measurement Manager.

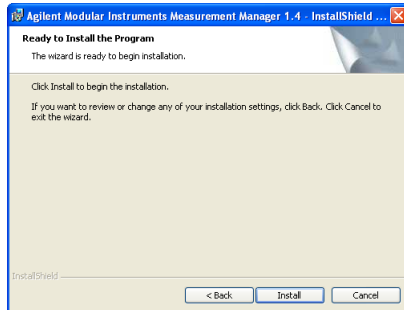

13 Click **Finish** when the installation has completed.

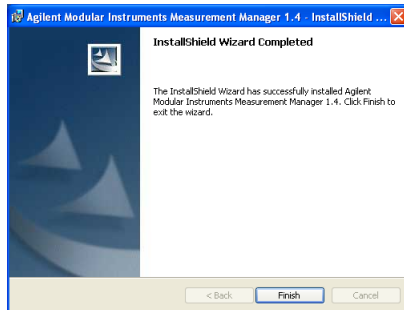

14 A shortcut to this software will be created on your desktop.

**NOTE**

USING THE LICENSED MATERIALS INDICATES YOUR ACCEPTANCE OF THE LICENSE TERMS. IF YOU DO NOT AGREE TO ALL OF THESE TERMS, YOU MAY RETURN ANY UNOPENED LICENSED MATERIALS FOR A FULL REFUND. IF THE LICENSED MATERIALS ARE BUNDLED OR PRE-LOADED WITH ANOTHER PRODUCT, YOU MAY RETURN THE ENTIRE UNUSED PRODUCT FOR A FULL REFUND.

## F. Connect Your DAQ Device to the PC

**NOTE**

Refer to *Agilent U2300A Series USB Multifunction Data Acquisition Devices User's Guide* for "Connect Your DAQ Device to PC" procedure.

During DAQ connectivity, the bundled power supply splitter in U2802A is used to supply power for both U2802A and U2355/56A DAQ, replacing the power supply cable.

---

## G. Hardware Verification

**NOTE**

Refer to *Agilent U2300A Series USB Multifunction Data Acquisition Devices User's Guide* for "Hardware Verification" procedure.

---

## H. Connect Your U2802A to DAQ

- 1 Connect U2802A to U2355/56A DAQ using two 68-pin SCSI cables.
- 2 Connect 12 VDC power supply to the power jack on the rear panel of the U2802A and the U2355/56A DAQ with the bundled power supply splitter.
- 3 Power on U2355A or U2356A DAQ.

## I. Launch Your Agilent Measurement Manager

**NOTE**

- The Agilent IO Control will launch automatically when you start your PC.
- Launching Agilent Measurement Manager without Agilent IO Control running will cause Agilent Measurement Manager to fail from detecting or establishing any connection with the USB DAQ device connected to your PC.
- To run Agilent IO Control, go to **Start > All Programs > Agilent IO Libraries Suite > Utilities > IO Control**.

- 1 Double-click the Agilent Measurement Manager software icon on your desktop or go to **Start > All Programs > Agilent > Measurement Manager > Agilent Measurement Manager** to launch the software.
- 2 The Agilent Measurement Manager welcome screen will appear as shown below.



- 3 The Select USB Device dialog box will appear and shows the connected DAQ devices. To start the application, select a DAQ device and click **OK** to establish the connection.



**NOTE**

For more information on how to use the Agilent Measurement Manager, refer to the *Agilent Measurement Manager Help File*.

## IVI-COM Drivers

The Agilent IVI-COM drivers simplify instrument control when you are working in a COM-compatible environment. IVI-COM allows you to programmatically control your instrumentation and make measurements while providing a greater degree of instrument interchangeability and code reuse. The Agilent IVI-COM drivers support the use of IntelliSense for even greater ease-of-use within a Microsoft development environment.

The Agilent IVI-COM driver supports all Agilent Series DAQs. The Agilent Firmware Revision: A.2006.10.10 is the minimum revision required for full driver functionality.

An IVI-COM driver can program a particular set of instrument models. It implements an instrument-specific interface tuned to the capabilities of those models. The driver may also implement an IVI class-compliant interface which implements a limited set of functionality common to all instruments of the class. Instrument class-compliant interfaces are defined by the IVI Foundation. The application writer must choose whether to use the instrument-specific interface or the class-compliant interface.

The IVI inherent capabilities, through the IIVI driver interface, are available in both the instrument-specific interface and class-compliant interface. The general programming techniques are also the same.

### Choosing Instrument-Specific Interface

With this interface, you have the benefit of full access to the instrument's capabilities. All capabilities in the class-compliant interface are also covered by the instrument-specific interface, but you will find some capabilities in the instrument-specific interface that are not available through the class-compliant interface. You may also see some performance enhancements, as the driver can be tuned to use efficient programming methods for that particular instrument.

### Choosing Class-Compliant Interface

By limiting your program to the class-compliant interface, you have the potential advantage of syntactic interchangeability. Hence, another IVI-COM driver (and instrument) which supports the same class could be substituted for the original driver, if the prior IVI-COM driver supports all the capability groups used in the original driver. In this case, the

application will compile, link, and execute without error. The test results, however, may be quite different because different instruments measure and generate signals differently. For more information on class-compliant interfaces and capability groups, visit [www.ivifoundation.org](http://www.ivifoundation.org).

### Using Class-Compliant Interface

Generally, you gain no advantage from using class-compliant interface over using just the instrument-specific interface. However, if you can isolate the usage of the instrument-specific interface, you may see some advantages. Replacing the IVI-COM driver then involves fixing the syntactic incompatibilities in the isolated code.

IVI-COM drivers will be provided to users. The drivers can also be used in a variety of development environments. For more information on IVI, visit [www.ivifoundation.org](http://www.ivifoundation.org).

Below are the IVI-COM drivers provided:

- ✓ AgilentVEE support through COM mechanism using IVI-COM
- ✓ Visual Basic 6 support through COM mechanism using IVI-COM
- ✓ C++ support through COM mechanism using IVI-COM
- ✓ Visual Basic 7 support through COM Interop mechanism using IVI-COM
- ✓ C# support through COM Interop mechanism using IVI-COM
- ✓ National Instruments LabVIEW support through COM mechanism using IVI-COM

The Agilent firmware update utility is provided to allow users to update firmware on instruments. Update is made available through Agilent Developer Network (ADN) website:

[www.agilent.com/find/adn](http://www.agilent.com/find/adn)

## Programming Environments

An IVI-COM driver works well in a variety of application development environments (ADEs) below:

- ✓ Agilent VEE
- ✓ Microsoft® Visual Basic® 6
- ✓ Visual Studio C++
- ✓ Visual Basic 7
- ✓ C#
- ✓ National Instruments LabVIEW

## IVI-COM Driver Installation

- 1 Verify that your PC meets the minimum system requirements. (See 'System Requirements' on [page 9](#).)
- 2 Close all other applications on your PC.
- 3 Insert the *Product Reference CD* into the CD-ROM drive of your PC.
- 4 Wait for a few seconds for the auto-run window to appear.
- 5 If the auto-run window does not appear automatically, click **Start > Run**, then type <drive>:\Autorun.exe, where <drive> is your CD drive alphabet.
- 6 When the auto-run window appears, click **Software Driver** on the Agilent Modular Products Installation Menu.

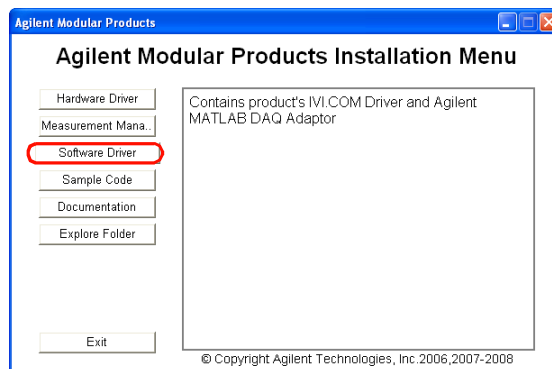

- 7 Click **IVI-COM** to open the IVI-COM Driver Installation Menu.

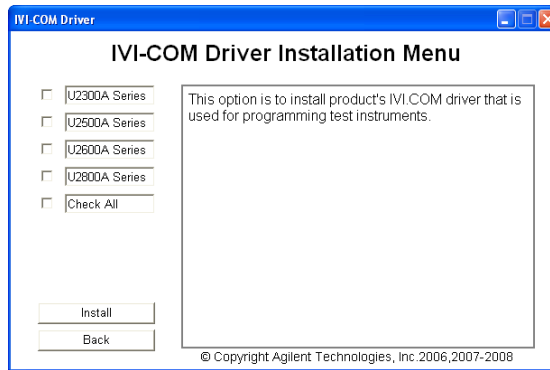

- 8 Check on the U2300A Series and click **Install** and wait for the Installation Dialog to appear.
- 9 When the Installation Dialog appears, click **Next** to begin the IVI Driver installation.
- 10 Read the License Agreement(s). To accept the terms, click on the radio button labeled **I accept the terms in the License Agreement** then click **Next** to continue.
- 11 When the **Setup Type** dialog box appears, as shown below, clicking **Install** will install all features for your configuration in standard locations on your PC.

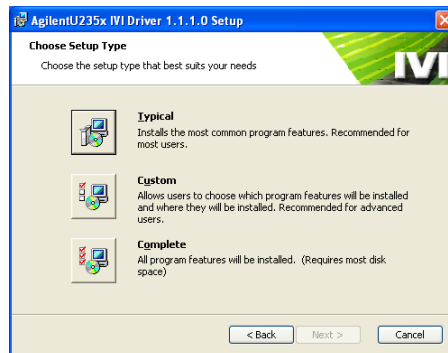

- 12 If you choose a **Custom** setup, the **Select Features** dialog box will appear.
  - a Click on any feature in the list to see the feature's description and space requirement. It is recommended that you install the sample programs if you plan to program with the IVI driver. However, you may omit this recommendation to save space.
  - b Select the check box for each feature to be installed. Clear the check box to omit the feature selection.
  - c Click **Next**.
- 4 When the **Ready to Install** dialog box appears, click **Install** to confirm your choices and begin copying files.
- 5 When the **Complete** dialog box appears, click **Finish**.



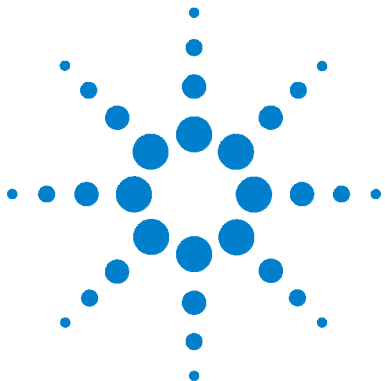

## 2 Features and Functions

- Features 26
- Applications 27
- System Overview 28
- Theory of Operation 29
  - Functionality of the System 29
  - Functional Block Diagram 30

This chapter contains details of the product features, applications, system overview and theory of operation. From this chapter, you will understand the Agilent U2802A 31-channel thermocouple input system overview and functionality of this device.



# Features

The U2802A Thermocouple Input conditioning device is complete with the following features:

- ✓ Up to 31 differential input mode, or 31-single ended inputs in voltage input mode. Each of the 31 channels can be configured as either thermocouple or voltage input mode independently.
- ✓  $\times 97.673$  gain setting for thermocouple input mode.
- ✓ Built-in thermistor for cold junction compensation (CJC).
- ✓ Built-in zeroing function to compensate for overall system offset errors due to temperature drift.
- ✓ On-board EEPROM that allows user to restore back original factory calibration data.
- ✓ Open thermocouple detection that allows user to check for any loose or broken thermocouple connection before starting the data acquisition process.
- ✓ Supports thermocouple type J, K, R, S, T, N, E, and B.

## Applications

The U2802A Thermocouple Input conditioning device is designed for robust and demanding industrial applications. This product is suitable for a wide range of applications in various fields inclusive of:

- ✓ Consumer electronics
  - Product thermal analysis and characterization
  - Environmental testing (Eg: Temperature Cycle)
  - Process monitoring (Eg: Oven or solder reflow temperature monitoring)
- ✓ Education
  - Study of electronic cooling properties
  - Material properties testing
- ✓ Container temperature profiling
- ✓ Appliances testing

## System Overview

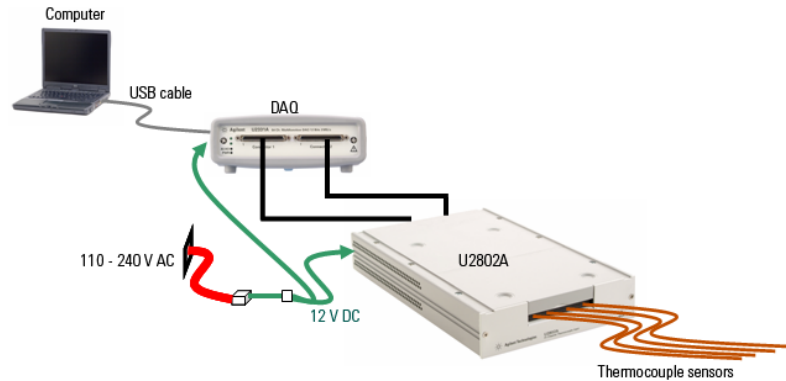

**Figure 2-1** System overview of U2802A with DAQ

The U2802A is essentially an amplifier module with a built-in temperature sensor (thermistor). In thermocouple mode, the U2802A input channel is used to amplify a differential voltage signal from a thermocouple (or any low voltage signal source in the range of  $\pm 100$  mV) by 100 times. The signal is then output as an analog voltage in the  $\pm 10$  V range into the DAQ for conversion to a digital voltage reading.

The built-in thermistor in the U2802A can be read from Channel AI148 of the U2300A series DAQ. The conversion from voltage to temperature for this thermistor reading is done automatically by the AMM software. This temperature reading will subsequently be used as the Cold Junction Compensation (CJC) reference temperature.

With the correct voltage reading from the thermocouple and the CJC temperature, the AMM software will then proceed to convert the thermocouple voltage reading into a temperature reading, based on the NIST ITS-90 Thermocouple Database. This reading is then corrected for both gain and offset errors due to the U2802A amplifiers using the calibration constants stored in the U2802A EEPROM, which are read by the PC via the DAQ's digital I/O lines.

The U2802A also has a built-in zeroing function, which allows users to zero out the entire system's offset error, thus increasing the overall accuracy of the system.

# Theory of Operation

## Functionality of the System

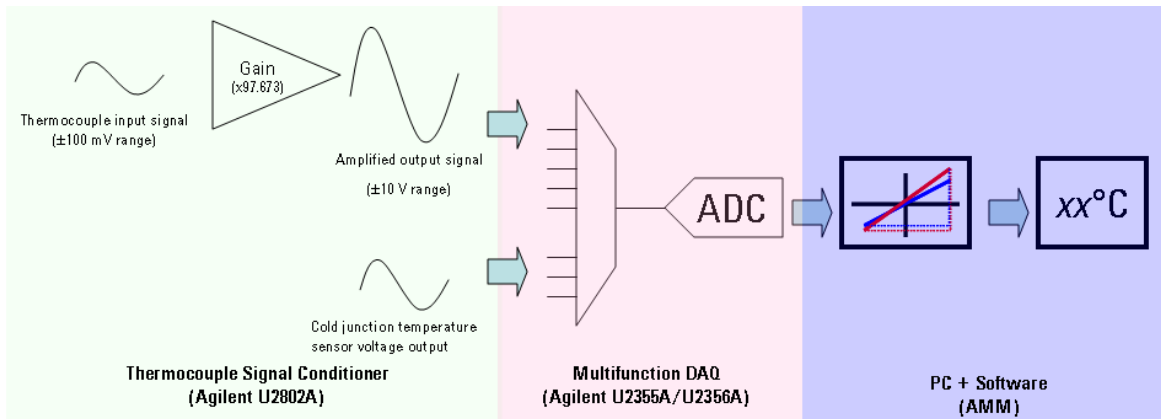
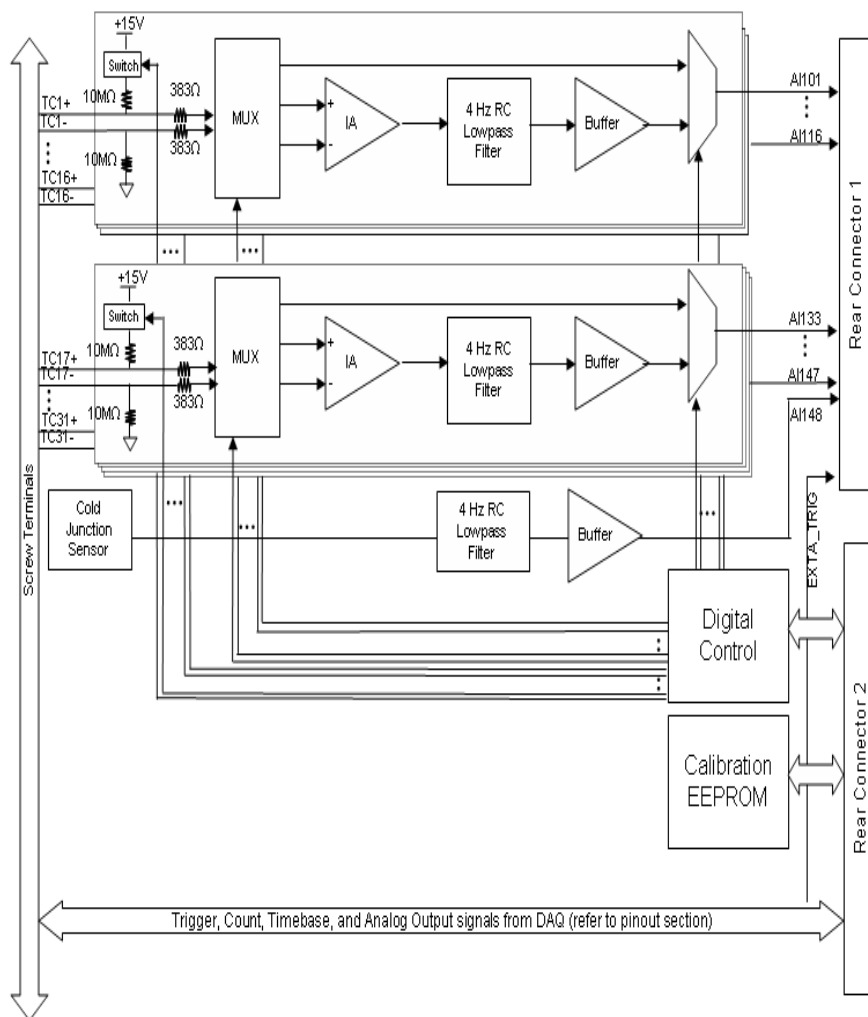

**Figure 2-2** System functionality block diagram for U2802A

- 1 Thermocouple voltage signals are detected at the U2802A thermocouple inputs.
- 2 Signal is amplified with a gain of 97.673 by the U2802A.
- 3 The U2355A or U2356A DAQ converts the analog voltage signals to digital voltage readings.
- 4 The AMM software (or IVI-COM driver) reads the Gain and Offset calibration constants from the U2802A EEPROM via the DAQ DIO lines. The digital voltage readings will be calibrated based on these constants.
- 5 The AMM software (or IVI-COM driver) converts the calibrated voltage readings to temperature readings using the ITS-90 conversion polynomials.

## Functional Block Diagram

The block diagram below in Figure 2-3 illustrates the key functional components of the U2802A.



**Figure 2-3** Functional block diagram for U2802A

The major functional blocks of the U2802A module are:

- Analog input channel circuitry
- Cold junction sensor
- Digital control logic
- EEPROM

### Analog input channel circuitry

The analog circuitry for each channel consists of an instrumentation amplifier with a fixed gain of 97.673, a 4 Hz RC low-pass filter, and an output buffer. The multiplexers at the input and output of each channel allows each channel to be configured for three modes of operation as listed below:

**Thermocouple input mode:** In thermocouple mode, the thermocouples (or any floating voltage source) should be connected to the TCn+ and TCn- terminals as illustrated in Figure 2-4. All TCn- terminals are internally tied to module ground with a 10 MΩ resistor. The TCn+ and TCn- signals are routed to the differential inputs of the instrumentation amplifier. Differential voltage signals at the TCn+ and TCn- terminals are amplified, filtered and driven out by single-ended output voltage to the corresponding AI channel on Rear Connector 1.

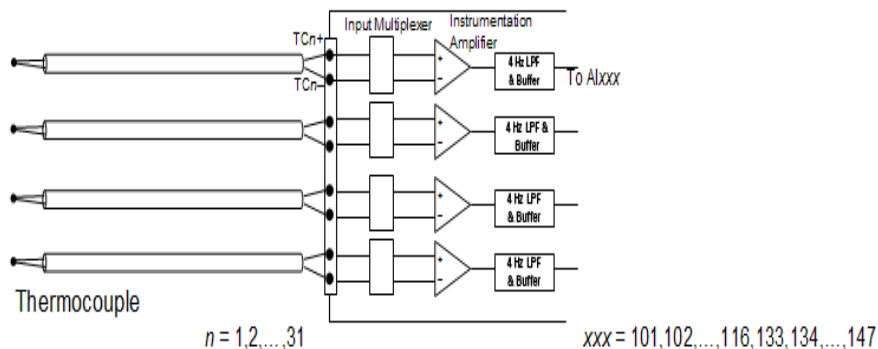

**Figure 2-4** Functional block diagram for thermocouple mode in U2802A

**Bypass mode:** In bypass mode, the TCn+ input is routed directly to the corresponding AI channel on Rear Connector 1. The single-ended signals tied to TCn+ should be referenced to a GND pin, and not to the TCn- input, as it is not directly connected to GND. The signal connection will depend on the type of source used.

For floating signal sources, all input signals are connected to the ground in the U2802A as illustrated in Figure 2-3. However, it is not recommended to tie ground-referenced signal sources in this manner. Any potential differences between the signal source ground and the U2802A ground could potentially induce excessive current to flow through the ground wires causing the wires and module to be damaged.

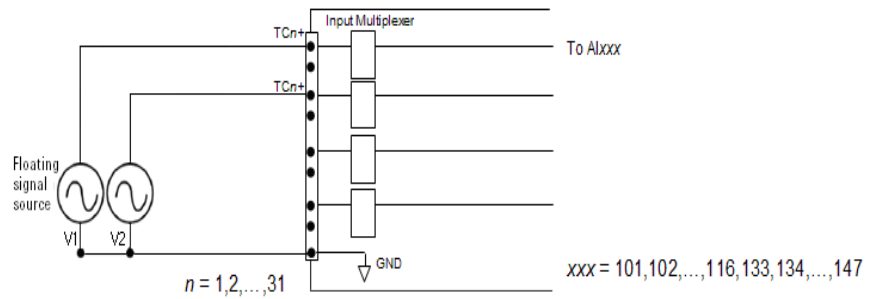

**Figure 2-5** Floating signal source configuration in U2802A

For ground-referenced signal sources and differential signal sources, the configuration in Figure 2-6 is recommended. Take note that the corresponding DAQ channel will need to be configured as a DIFF input to enable this type of connection.

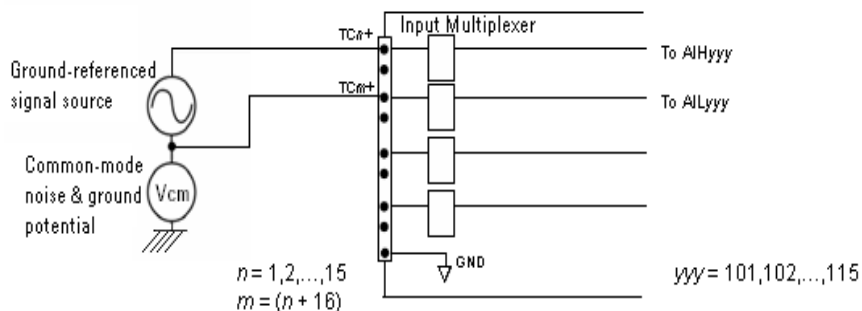

**Figure 2-6** Ground-referenced and differential signal sources configuration in U2802A

**Zero mode:** In zero mode, the positive and negative inputs of the instrumentation amplifier are shorted together. The output of the instrumentation amplifier is driven out to the corresponding AI channel. The voltage measured in this mode corresponds to the offset voltage of the channel. This voltage can be subtracted out of the subsequent thermocouple mode measurements in order to increase the measurement accuracy. Do take note that this mode only works for channels that have been configured to be in the thermocouple mode. Channels configured for bypass mode will not be affected when this mode is selected.

Each channel is equipped with an open thermocouple detection feature, where the 10 M $\Omega$  resistor is tied to the +15 V power supply rail. This feature can only be globally enabled or disabled for all channels, regardless of the channel mode setting. When enabled, outputs of the channels are set to thermocouple mode where the inputs are left open-circuited. This causes the positive power supply rail voltage (above +10 V) to be saturated up, indicating that the channel either has a broken thermocouple or the thermocouple is not connected. For channels set to bypass mode, channels with an open-circuited input will also be saturated to the positive supply rail voltage.

For bypass mode channels that are connected to valid voltage sources, the 10 M $\Omega$  pull-up resistor will cause additional current to flow through the voltage source. However, this additional current measurement is small and negligible for low impedance voltage sources.

For thermocouple mode channels connected to valid thermocouples, the presence of the pull-up resistor introduces approximately 0.75  $\mu$ A of current through the thermocouple wires. This current introduces additional errors when using thermocouples with high resistances, and the measurement accuracy could be affected.

### **Cold junction sensor**

A thermistor (RT1) is placed in between the screw terminals to measure the temperature of the thermocouple junction for CJC. The output voltage from the sensor is fed through a 4 Hz RC low-pass filter and buffered to the AI148 pin on Rear Connector 1. The conversion from voltage to temperature is done automatically by the AMM software.

### **Digital control**

The digital control circuit consists of registers that controls the mode of each channel and the open-thermocouple detect feature. The registers are addressed and clocked via the digital I/O pins on Rear Connector 2. This will be handled automatically by the AMM software.

### **EEPROM**

The gain and offset calibration factors for each channel are stored in the EEPROM during factory calibration and will be retrieved prior to taking measurements. The EEPROM is tied to the digital I/O pins on Rear Connector 2. The communication between the EEPROM and host PC is automatically handled by the AMM software. In addition to the calibration factors, the EEPROM stores the module ID, serial number, date of calibration, which can also be retrieved before measurements are taken.

### Open Thermocouple Detection

The U2802A provides a built-in 10 M $\Omega$  resistor on each TC+ terminal, which is pulled up to the internal +15 V power supply rail. This resistor can be enabled or disabled via the digital I/O pins on Rear Connector 2. When enabled, this 10 M $\Omega$  pull-up resistor and the 10 M $\Omega$  pull-down biasing resistor will cause the output from any unconnected thermocouple input channels to saturate to the maximum output voltage. The U2355A and U2356A devices can read this saturated channel and detect that a particular channel has an open thermocouple input.

### Trigger, Counter, External Timebase, and Analog Output

The U2802A provides a direct access to the analog and digital trigger lines, counter channels, external timebase input, and analog output channels from the U2355A and U2356A devices. These lines are routed directly from the Rear Connector 1 and 2 to the J60 screw terminal connector. Please refer to pin description for **Connector J60** on [page 43](#). Precautions should be taken when driving high slew rate and frequency clocks into the Counter and External Timebase lines to avoid excessive noise coupling into other analog and digital lines. If excessive coupling or crosstalk is observed, clock output drive strengths and slew rates should be lowered to reduce coupling while still maintaining proper digital function.

## 2 Features and Functions

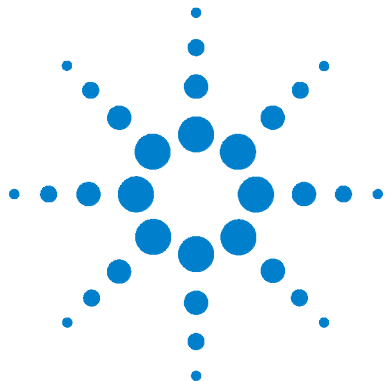

## 3 Pin Configurations and Assignments

Pin Configurations	38
Pin Assignments	38
Pin Description	39
Connector Pinout	44

This chapter described the Agilent U2802A 31-channel thermocouple input device pin configurations and connector pinout for user's reference.



# Pin Configurations

## Pin Assignments

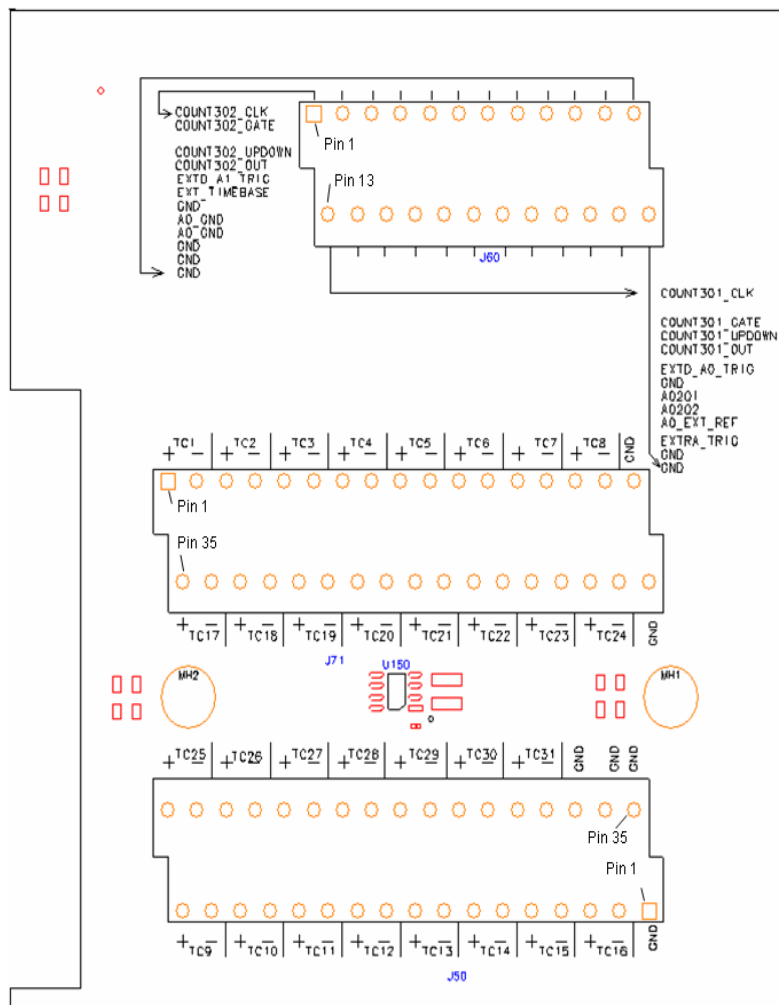

Figure 3-1 U2802A pin assignment

## Pin Description

### Connector J71

Pin	Pin name	Description
1	TC1+	In thermocouple mode, TCx+ and TCx– are the thermocouple differential input. In voltage mode, single ended input at TCx+ and GND. TCx– is not connected.
2	TC1–	
3	TC2+	TC input or voltage input (See TC1+/- description)
4	TC2–	
5	TC3+	TC input or voltage input (See TC1+/- description)
6	TC3–	
7	TC4+	TC input or voltage input (See TC1+/- description)
8	TC4–	
9	TC5+	TC input or voltage input (See TC1+/- description)
10	TC5–	
11	TC6+	TC input or voltage input (See TC1+/- description)
12	TC6–	
13	TC7+	TC input or voltage input (See TC1+/- description)
14	TC7–	
15	TC8+	TC input or voltage input (See TC1+/- description)
16	TC8–	
17	GND	Module Ground
18	TC17+	TC input or voltage input (See TC1+/- description)
19	TC17–	
20	TC18+	TC input or voltage input (See TC1+/- description)
21	TC18–	
22	TC19+	TC input or voltage input (See TC1+/- description)
23	TC19–	
24	TC20+	TC input or voltage input (See TC1+/- description)
25	TC20–	
26	TC21+	TC input or voltage input (See TC1+/- description)
27	TC21–	

### 3 Pin Configurations and Assignments

28	TC22+	TC input or voltage input (See TC1+/- description)
29	TC22-	
30	TC23+	TC input or voltage input (See TC1+/- description)
31	TC23-	
32	TC24+	TC input or voltage input (See TC1+/- description)
33	TC24-	
34	GND	Module Ground

**Connector J50**

Pin	Pin name	Description
1	GND	Module Ground
2	TC16-	TC input or voltage input (See TC1+/- description)
3	TC16+	
4	TC15-	TC input or voltage input (See TC1+/- description)
5	TC15+	
6	TC14-	TC input or voltage input (See TC1+/- description)
7	TC14+	
8	TC13-	TC input or voltage input (See TC1+/- description)
9	TC13+	
10	TC12-	TC input or voltage input (See TC1+/- description)
11	TC12+	
12	TC11-	TC input or voltage input (See TC1+/- description)
13	TC11+	
14	TC10-	TC input or voltage input (See TC1+/- description)
15	TC10+	
16	TC9-	TC input or voltage input (See TC1+/- description)
17	TC9+	
18	GND	Module Ground
19	GND	Module Ground
20	GND	Module Ground
21	TC31-	TC input or voltage input (See TC1+/- description)
22	TC31+	
23	TC30-	TC input or voltage input (See TC1+/- description)
24	TC30+	
25	TC29-	TC input or voltage input (See TC1+/- description)
26	TC29+	
27	TC28-	TC input or voltage input (See TC1+/- description)
28	TC28+	
29	TC27-	TC input or voltage input (See TC1+/- description)
30	TC27+	

### 3 Pin Configurations and Assignments

31	TC26-	TC input or voltage input (See TC1+/- description)
32	TC26+	
33	TC25-	TC input or voltage input (See TC1+/- description)
34	TC25+	

**Connector J60**

Pin	Pin name	Description
1	COUNT302_CLK	Directly connected to DAQ <sup>1</sup>
2	COUNT302_GATE	Directly connected to DAQ <sup>1</sup>
3	COUNT302_UPDOWN	Directly connected to DAQ <sup>1</sup>
4	COUNT302_OUT	Directly connected to DAQ <sup>1</sup>
5	EXTD_AI_TRIG	Directly connected to DAQ <sup>1</sup>
6	EXT_TIMEBASE	Directly connected to DAQ <sup>1</sup>
7	GND	Module Ground
8	AO_GND	Directly connected to DAQ <sup>1</sup>
9	AO_GND	Directly connected to DAQ <sup>1</sup>
10	GND	Module Ground
11	GND	Module Ground
12	GND	Module Ground
13	COUNT301_CLK	Directly connected to DAQ <sup>1</sup>
14	COUNT301_GATE	Directly connected to DAQ <sup>1</sup>
15	COUNT301_UPDOWN	Directly connected to DAQ <sup>1</sup>
16	COUNT301_OUT	Directly connected to DAQ <sup>1</sup>
17	EXTD_AO_TRIG	Directly connected to DAQ <sup>1</sup>
18	GND	Module Ground
19	A0201	Directly connected to DAQ <sup>1</sup>
20	A0202	Directly connected to DAQ <sup>1</sup>
21	AO_EXT_REF	Directly connected to DAQ <sup>1</sup>
22	EXTA_TRIG	Directly connected to DAQ <sup>1</sup>
23	GND	Module Ground
24	GND	Module Ground

1. Refer to the *U2300A Series USB Multifunction Data Acquisition Devices User's Guide* for connectivity

# Connector Pinout

## Rear panel pinout for Connector 1

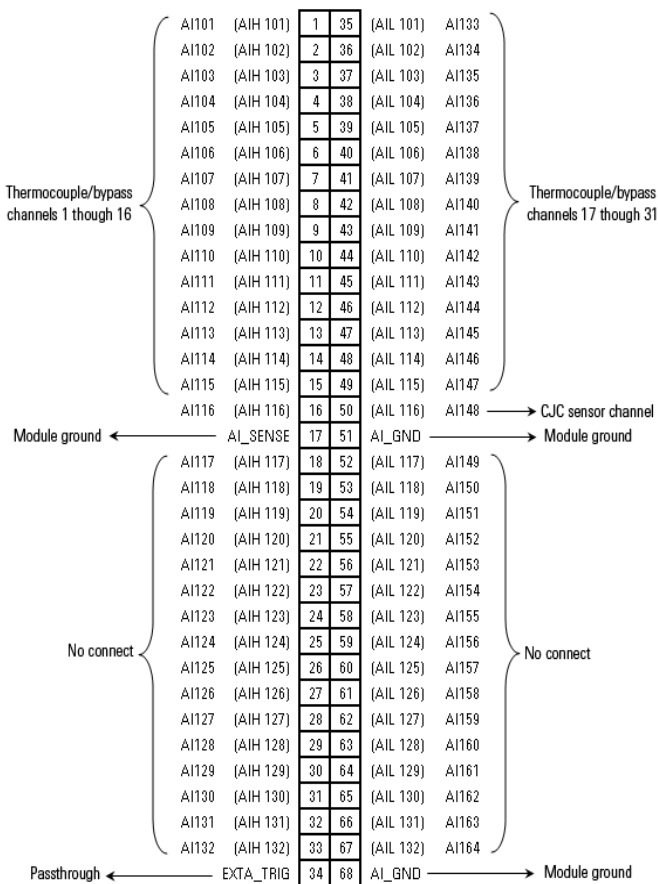

\* Passthrough means that the signals are routed out to connector J60 on U28082A

Figure 3-2 Connector 1 pin assignment for U2355A and U2356A

## Rear panel pinout for Connector 2

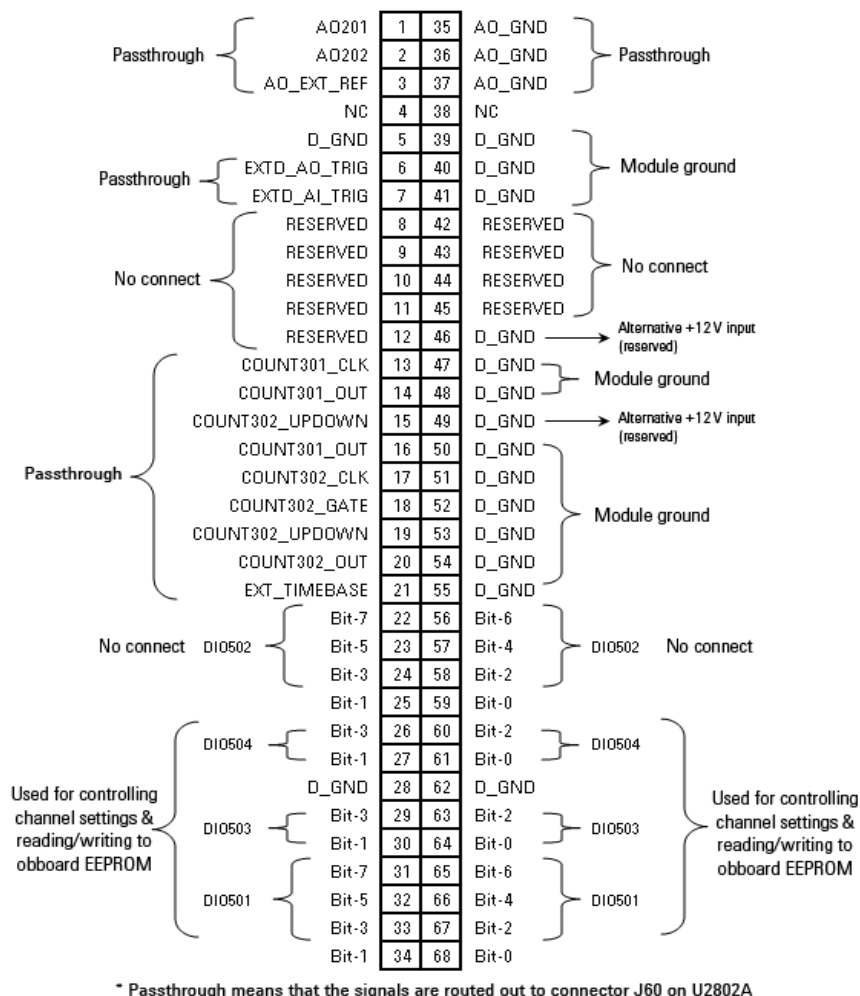
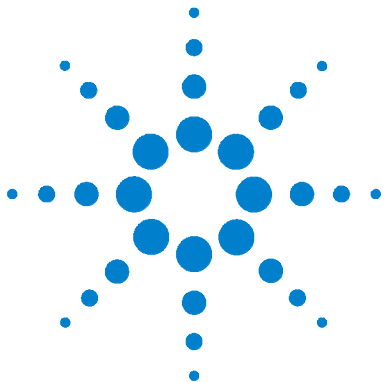

Figure 3-3 Connector 2 pin assignment for U2355A and U2356A

### **3 Pin Configurations and Assignments**



## 4 Product Specifications

General Specifications	48
Product Characteristics	49
System Accuracy Specifications	51
Calculating System Accuracy	54
System Typical Performance	57
Making Accurate Temperature Measurements	59

This chapter specifies the environmental conditions, characteristics, and specifications of the Agilent U2802A 31-channel thermocouple input device. It also covers the system accuracy, typical performance and guidelines to make accurate temperature measurements.



## General Specifications

---

**POWER CONSUMPTION**

±12 VDC, 750 mA maximum

---

**OPERATING ENVIRONMENT**

- Operating temperature from 0 °C to 55 °C
- Relative humidity at 50% to 85% RH (non-condensing)
- Altitude up to 2000 meters

---

**STORAGE COMPLIANCE**

–40 °C to 70 °C

---

**SAFETY COMPLIANCE**

Certified with IEC 61010-1:2001/EN 61010-1:2001 (2nd Edition)

---

**EMC COMPLIANCE**

- IEC 61326-1:2002 / EN 61326-1:1997+A1:1998+A2:2001+A3:2003
- CISPR 11:1990/EN55011:1990 – Group 1, Class A
- CANADA: ICES-001: 2004
- Australia/New Zealand: AS/NZS CISPR11:2004

---

**SHOCK & VIBRATION**

Tested to IEC/EN 60068-2

---

**IO CONNECTOR**

- 2 x 68-pin female SCSI connector
- 2 x 34-pin screw terminal block
- 1 x 24 pin screw terminal block

---

**DIMENSIONS (WxDxH)**

159.7 mm x 254.2 mm x 40.5 mm

---

**WEIGHT**

1.036 KG

---

**WARRANTY**

Three years

---

## Product Characteristics

<b>GENERAL CHARACTERISTICS</b>	
Number of channels	31 differential and 1 CJC
Input voltage range for voltage mode	$\pm 10$ V (signal + common mode)
Input voltage (thermocouple mode)	$\pm 100$ mV
Sampling rate for thermocouple mode	10 kSa/s total for all channels
Sampling rate for overall module	500 kSa/s
Thermocouple types	J, K, R, S, T, N, E and B
<b>INPUT SPECIFICATIONS</b>	
Accuracy (thermocouple mode)	
Overall gain error	0.06% (23 °C $\pm$ 5 °C)
Overall offset error	15 $\mu$ V (without zeroing) (23 °C $\pm$ 5 °C)
	6 $\mu$ V (with zeroing)
Nonlinearity	< 0.005% of Full Scale Range
System noise (rms)	
Gain (x1)	100 $\mu$ Vrms
Gain (x100)	5 $\mu$ Vrms
Common mode rejection ratio (60 Hz)	
Voltage mode	> 60 dB
Thermocouple mode	> 80 dB
Cold junction accuracy	$\pm 1.0$ °C typical (23 °C $\pm$ 5 °C)
	$\pm 1.5$ °C typical (0 °C to 18 °C, 28 °C to 55 °C)
<b>INPUT CHARACTERISTICS</b>	
Bandwidth (voltage mode)	> 500 kHz
Bandwidth (thermocouple mode)	4.0 Hz

## 4 Product Specifications

Overvoltage protection <sup>i</sup>	<p><b>TC Mode<sup>ii</sup></b></p> <ul style="list-style-type: none"> <li>• Common mode: <math>\pm 17</math> V (TC+ and TC– with respect to GND)</li> <li>• Differential mode: <math>\pm 7</math> V (Differential voltage between TC+ and TC–)</li> </ul> <p><b>Bypass mode</b></p> <ul style="list-style-type: none"> <li>• <math>\pm 20</math> V (TC+ input with respect to GND)</li> </ul> <p><b>Power Off Mode</b></p> <ul style="list-style-type: none"> <li>• <math>\pm 11</math> V (TC+, TC– input with respect to GND)</li> </ul>
Input impedance	$> 1$ G $\Omega$
Input bias current	$\pm 2.5$ nA max
Input offset current	$\pm 1.5$ nA max
Gain drift	60 ppm / °C max
Offset drift	1 $\mu$ V / °C max
Filter cutoff frequency ( $-3$ dB) (thermocouple mode)	4.0 Hz
Filter type (thermocouple mode)	Low Pass RC Filter
<b>OTHER FEATURES</b>	
Recommended warm up time	30 minutes

- i The overvoltage protection levels specified above indicate the maximum voltage each input pin can tolerate without resulting in any damages. However, prolonged exposure to these levels may affect device safety and reliability. Hence, it should be avoided where possible.
- ii On the channels configured for thermocouple mode, the TC+ and TC– pins can tolerate up to  $\pm 17$  V of differential voltage for a few minutes. However, exceeding  $\pm 100$  mV voltage range on these channels can cause additional current to be drawn from the device's power supply regulators, which may damage the device if multiple channels are overdriven for prolonged periods. This applies to the case where a voltage source is tied across the TC<sub>n</sub>+ and TC<sub>n</sub>– pin. Voltage sources greater than  $\pm 100$  mV should be tied to TC<sub>n</sub>+ and GND (floating source), or TC<sub>n</sub>+ and TC<sub>n+1</sub>+ (grounded source), and have the channels set for bypass mode. Refer to [Figure 2-5](#) on page 32.

## System Accuracy Specifications

The Agilent U2802A thermocouple input measurement accuracy with the U2355A and U2356A is as shown in [Table 4-1](#), [Table 4-2](#), and [Table 4-3](#).

### NOTE

- Assume a  $\pm 1$  °C error in the CJ measurement due to sensor error and temperature gradient error in the accuracy numbers in [Table 4-1](#), [Table 4-2](#), and [Table 4-3](#) below.
- [Table 4-1](#), [Table 4-2](#), and [Table 4-3](#) are derived from the U2802A and DAQ input accuracy specifications without including the thermocouple error. Refer to [“Calculating System Accuracy”](#) on page 54 for calculation methodology.

Thermocouple Measurements Accuracy (U2355A, U2356A @ 23 °C $\pm$ 5 °C)							
T/C Type	ITS-90 Temperature Range (°C)		Optimum Measurement Range (°C)		Without averaging ( $\pm$ °C)	50 points averaging ( $\pm$ °C)	500 points averaging ( $\pm$ °C)
	Low	High	Low	High			
B	0	1820	1100	1820	1.9	1.2	1.0
			400	1100	4.4	2.5	2.0
E	-270	1000	-150	1000	1.7	1.6	1.6
			-200	-150	2.4	2.3	2.3
J	-210	1200	-150	1200	1.6	1.5	1.5
			-210	-150	2.7	2.6	2.5
K	-270	1372	-100	1200	1.5	1.4	1.4
			-200	-100	2.7	2.6	2.6
N	-270	1300	-100	1300	1.5	1.3	1.3
			-200	-100	3.0	2.7	2.6
R	-50	1768	300	1760	2.0	1.4	1.3
			-50	300	5.0	3.1	2.6
S	-50	1768	400	1760	2.1	1.6	1.4
			-50	400	4.5	2.8	2.4
T	-270	400	-100	400	1.5	1.4	1.4
			-200	-100	2.7	2.5	2.5

**Table 4-1** U2802A measurement accuracy with U2355A or U2356A, at 23 °C  $\pm$  5 °C, with different number of averaging points.

## 4 Product Specifications

Thermocouple Measurements Accuracy (U2355A @ 0 °C to 18 °C and 28 °C to 45 °C)							
T/C Type	ITS-90 Temperature Range (°C)		Optimum Measurement Range(°C)		Without averaging (± °C)	50 points averaging (± °C)	500 points averaging (± °C)
	Low	High	Low	High			
B	0	1820	1100	1820	3.4	2.4	2.2
			400	1100			
E	-270	1000	-150	1000	2.7	2.6	2.5
			-200	-150			
J	-210	1200	-150	1200	2.5	2.4	2.4
			-210	-150			
K	-270	1372	-100	1200	2.9	2.8	2.8
			-200	-100			
N	-270	1300	-100	1300	2.6	2.5	2.5
			-200	-100			
R	-50	1768	300	1760	3.8	3.1	3.0
			-50	300			
S	-50	1768	400	1760	4.2	3.4	3.2
			-50	400			
T	-270	400	-100	400	2.4	2.2	2.2
			-200	-100			

**Table 4-2** U2802A measurement accuracy with U2355A, at 0 to 18 °C and 28 to 45 °C, with different number of averaging points.

Thermocouple Measurements Accuracy (U2356A @ 0 °C to 18 °C and 28 °C to 45 °C)							
T/C Type	ITS-90 Temperature Range (°C)		Optimum Measurement Range(°C)		Without averaging (± °C)	50 points averaging (± °C)	500 points averaging (± °C)
	Low	High	Low	High			
B	0	1820	1100	1820	6.1	3.1	2.4
			400	1100	14.4	6.3	2.7
E	-270	1000	-150	1000	3.0	2.6	2.6
			-200	-150	4.2	3.7	3.6
J	-210	1200	-150	1200	2.9	2.5	2.5
			-210	-150	4.9	4.1	4.0
K	-270	1372	-100	1200	3.3	2.9	2.9
			-200	-100	5.3	4.2	4.0
N	-270	1300	-100	1300	3.4	2.7	2.6
			-200	-100	6.8	4.6	4.1
R	-50	1768	300	1760	6.2	3.7	3.2
			-50	300	15.7	7.2	3.8
S	-50	1768	400	1760	6.4	4.0	3.4
			-50	400	14.2	6.6	3.4
T	-270	400	-100	400	3.0	2.4	2.2
			-200	-100	5.3	4.2	3.9

**Table 4-3** U2802A measurement accuracy with U2356A, at 0 to 18 °C and 28 to 45 °C, with different number of averaging points.

## Calculating System Accuracy

The overall measurement system comprises of three major components:

- 1 DAQ (U2355A or U2356A)
- 2 Signal Conditioner (U2802A), which includes CJ Sensor error
- 3 Sensor (Thermocouples)

Errors introduced by each of the above components has to be accounted for when calculating the total system accuracy. Since errors from each component are not correlated with each other, the total system error will be the root-sum-square (RSS) of all the errors:

$$E_{\text{TOTAL}}^2 = E_{\text{DAQ}}^2 + E_{\text{SIG\_COND}}^2 + E_{\text{THERMOCOUPLE}}^2$$

### Example:

Assume the following conditions:

- DAQ: Agilent U2355A
- Signal Conditioning: Agilent U2802A
- Ambient temperature: 23 °C
- Thermocouple type: J-type, standard limits of error
- Temperature to measure: 600 °C

Assume the following error specifications:

- U2355A: Gain error = 0.02% of reading
- Offset error = 1 mV
- U2802A gain = 97.673
- Gain error = 0.06% of reading
- Offset error = 15 µV (with respect to input)
- Zeroing error = 6 µV (with respect to input)
- CJ measurement accuracy = 1 °C
- Thermocouple = greater than 2.2 °C or 0.75% error
- Noise error has been omitted to simplify the example

With zeroing, the offset errors from the DAQ and the U2802A can be removed, and replaced with the zeroing error.

Based on the ITS-90 Thermocouple table, a J-type thermocouple will output 33.102 mV at 600 °C, and changes at a rate of approximately 59  $\mu\text{V}/^\circ\text{C}$ . This corresponds to  $(33.102 \text{ mV} \times 97.673)$  or 3.2332 V at the input of the DAQ.

Hence,  $E_{\text{DAQ}}$ ,  $E_{\text{SIG\_COND}}$ , and  $E_{\text{ZEROING}}$  are calculated as follows:

- $E_{\text{DAQ}}$ 

$$= 0.02\% \times 33.102 \text{ mV}$$

$$= 6.62 \mu\text{V}$$

$$= 6.62 \mu\text{V} \div 59 \mu\text{V}/^\circ\text{C}$$

$$= 0.112 \text{ }^\circ\text{C}$$
- $E_{\text{SIG\_COND}}$ 

$$= (0.06\% \times 33.102 \text{ mV}) \div 59 \mu\text{V}/^\circ\text{C}$$

$$= 0.337 \text{ }^\circ\text{C}$$
- $E_{\text{ZEROING}}$ 

$$= 6 \mu\text{V} \div 59 \mu\text{V}/^\circ\text{C}$$

$$= 0.102 \text{ }^\circ\text{C}$$

Next, the cold junction sensor error is calculated.

At 23 °C, a J-type thermocouple output voltage changes at a rate of 52  $\mu\text{V}/^\circ\text{C}$ . Thus, the CJ sensor error of 1 °C at 23 °C corresponds to  $52 \mu\text{V}/^\circ\text{C} \times 1^\circ\text{C} = 52 \mu\text{V}$ .

At 600 °C,

- $E_{\text{CJC}}$ 

$$= 52 \mu\text{V} \div 59 \mu\text{V}/^\circ\text{C}$$

$$= 0.88 \text{ }^\circ\text{C}$$

## 4 Product Specifications

Therefore,

$$E_{\text{THERMOCOUPLE}} = 0.75\% \times 600 \text{ }^{\circ}\text{C} = 4.5 \text{ }^{\circ}\text{C}$$

Using the above individual component errors, the total measurement system accuracy is calculated as below.

### **System accuracy without thermocouple sensor error:**

$$\begin{aligned} E_{\text{TOTAL}} &= \text{SQRT}(E_{\text{DAQ}}^2 + E_{\text{SIG\_COND}}^2 + E_{\text{ZEROING}}^2 + E_{\text{CJC}}^2) \\ &= 0.95 \text{ }^{\circ}\text{C} \end{aligned}$$

### **System accuracy with thermocouple sensor error:**

$$\begin{aligned} E_{\text{TOTAL}} &= \text{SQRT}(E_{\text{DAQ}}^2 + E_{\text{SIG\_COND}}^2 + E_{\text{ZEROING}}^2 + E_{\text{CJC}}^2 + E_{\text{THERMOCOUPLE}}^2) \\ &= 4.6 \text{ }^{\circ}\text{C} \end{aligned}$$

# System Typical Performance

## Thermoelectric Characteristics

The thermoelectric characteristics for various thermocouple types is shown in Figure 2-1.

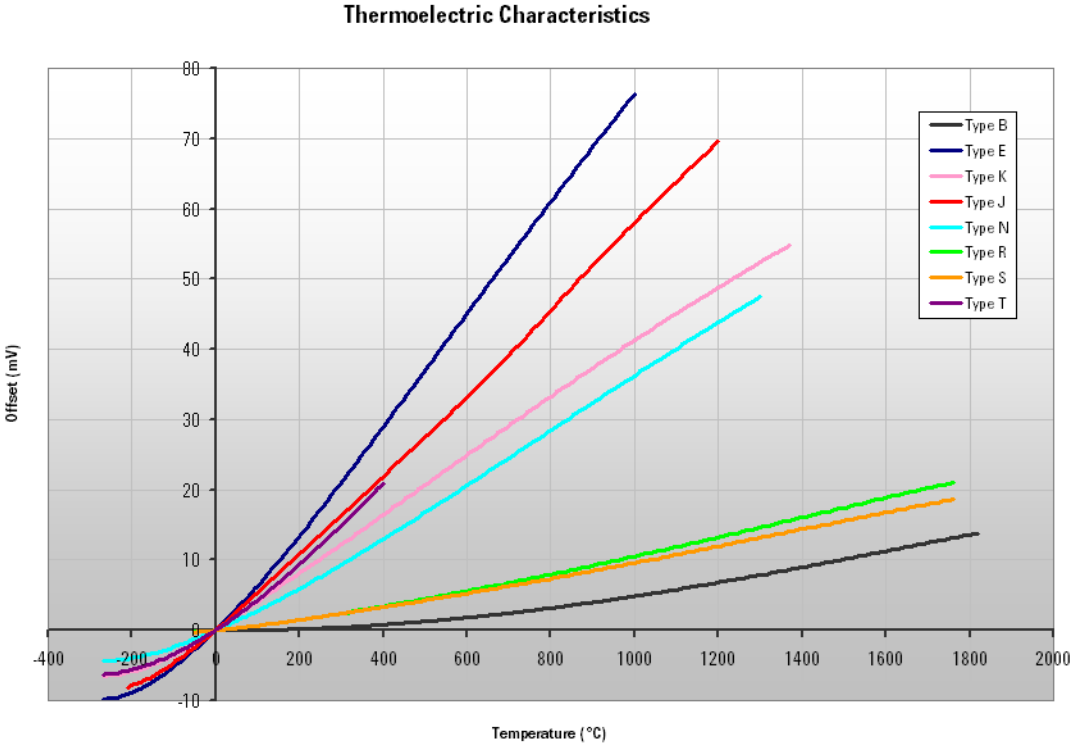
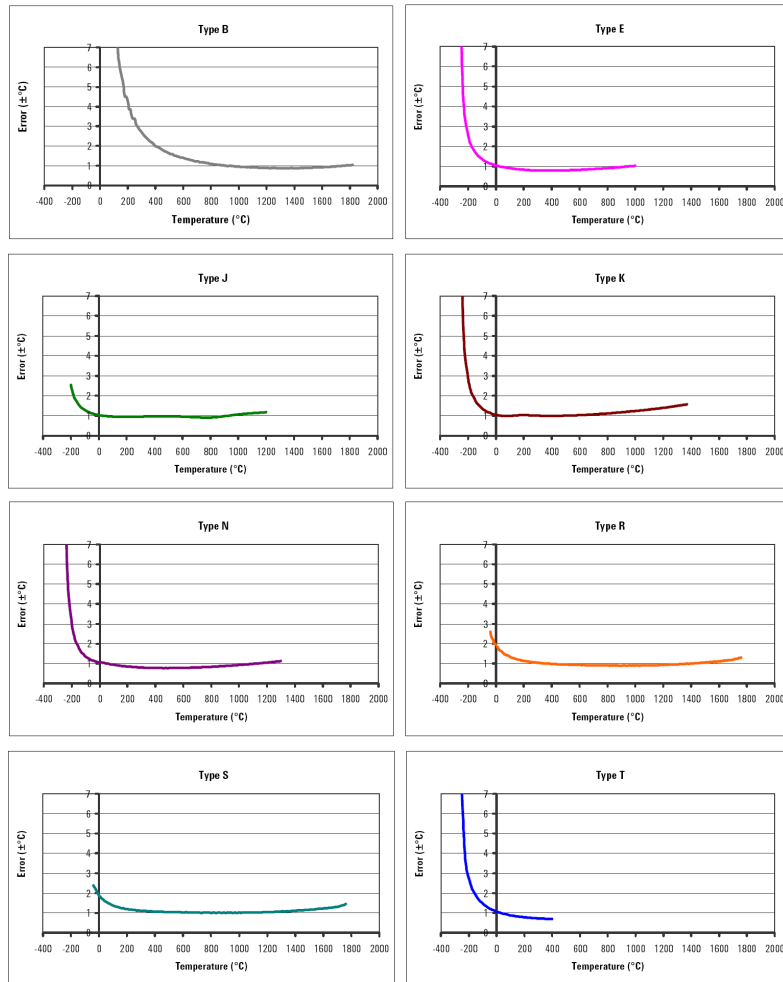

Figure 4-1 Thermoelectric characteristics for various thermocouple types

## Typical Error vs. Measurement Performance

The U2802A measurement error with U2355A or U2356A at  $23\text{ }^{\circ}\text{C} \pm 5\text{ }^{\circ}\text{C}$  is shown in Figure 2-2.



**Figure 4-2** U2802A measurement accuracy plot for various thermocouples type

**NOTE**

Assume a  $\pm 1\text{ }^{\circ}\text{C}$  error in the CJ measurement due to sensor error and temperature gradient error in the accuracy numbers in Figure 4-2.

## Making Accurate Temperature Measurements

Thermocouple measurement accuracy is very sensitive to cold junction sensor errors and temperature gradients across the terminals. Keep the module away from any heat sources and drafts to minimize any variation between channels.

The channels located closest to the center near the reference thermistor will have the best accuracy. It is important to use channels that are physically close together on the screw terminals when taking relative measurements. Channels that are closest together will have the best agreement.

## **4 Product Specifications**



## 5 Calibration

Calibration	62
Calibration Information	62
Zeroing Function	62
Restore Factory Calibration	63

This chapter contains the calibration information and factory restore calibration procedure for the Agilent U2802A 31-channel thermocouple input device.



## Calibration

### Calibration Information

The Agilent U2802A is factory calibrated and the calibration constants are stored in the EEPROM. During initial setup, the calibration constants are read from the EEPROM before any measurements are taken.

### Zeroing Function

The Agilent U2802A thermocouple input device operating in thermocouple mode can be set to zero mode, where the differential inputs of each channel are shorted together. This zeroing function is used to measure the total system offset errors due to initial offset error, temperature drift error, and long term drift error from the DAQ (U2355A or U2356A) and the U2802A. This measurement can then be subtracted from subsequent measurements in order to remove the system offset error.

## Restore Factory Calibration

The Restore Factory Calibration function in the Agilent U2802A is used to restore calibration data from user's settings to factory original settings. To perform factory restore calibration, follow the step-by-step instructions shown below:

- 1 Click **Restore Factory Calibration** in the thermocouple form.

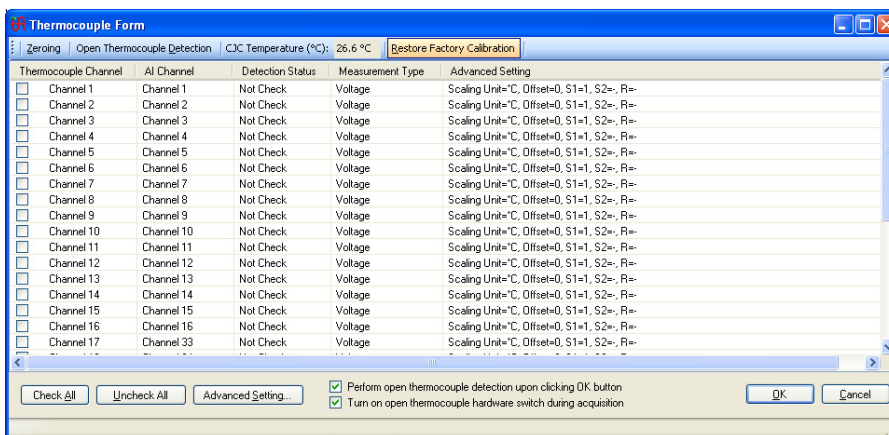

- 2 A dialog box will appear as shown below.

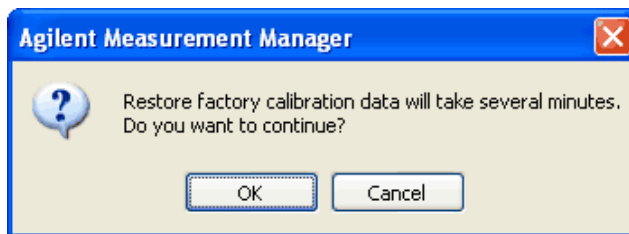

- 3 Click **OK** to start the factory restore calibration process. Click **Cancel** to not perform the restore factory calibration process.



**www.agilent.com**

**Contact us**

To obtain service, warranty or technical support assistance, contact us at the following phone numbers:

United States:

(tel) 800 829 4444 (fax) 800 829 4433

Canada:

(tel) 877 894 4414 (fax) 800 746 4866

China:

(tel) 800 810 0189 (fax) 800 820 2816

Europe:

(tel) 31 20 547 2111

Japan:

(tel) (81) 426 56 7832 (fax) (81) 426 56 7840

Korea:

(tel) (080) 769 0800 (fax) (080) 769 0900

Latin America:

(tel) (305) 269 7500

Taiwan:

(tel) 0800 047 866 (fax) 0800 286 331

Other Asia Pacific Countries:

(tel) (65) 6375 8100 (fax) (65) 6755 0042

Or visit Agilent World Wide Web at:

[www.agilent.com/find/assist](http://www.agilent.com/find/assist)

Product specifications and descriptions in this document subject to change without notice.

© Agilent Technologies, Inc. 2009

Second Edition, 7 September 2009

U2802-90003



**Agilent Technologies**