

EVALUATION DONGLE TEMPERATURE AND HUMIDITY SENSORS

1. Introduction

This user's guide describes the evaluation GUI and PCB board design for the following evaluation kits:

- Si7013USB-DONGLE kit for Si7013, Si7020, and Si7021
- Si7022-23-EVB kit for Si7022 and Si7023
- Si7006-07-EVB kit for Si7006 and Si7007
- Si7050/3/4/5-EVB kits for Si7050, Si7053, Si7054 and Si7055 temperature sensors
- Si7034-EVB kit

The GUI and USB dongle support both PWM output and I²C output devices.

2. Evaluation Kit Descriptions

All of the supported evaluation kits contain the following items:

- Si7013USB-DONGLE evaluation board consisting of one Si7013 sensor as well as USB interface and circuitry for evaluation of the Si7013 with thermistor or other analog input
- 3-foot flat cable to connect the “postage stamp” boards to the USB dongle
- USB extender cable
- Windows graphical user interface software for complete control of the Si70xx sensors (Windows XP, VISTA, or 7 required)

Depending on the kit, different postage stamp boards are supplied as well.

- The Si7013USB-Dongle kit has Si7013, Si7020, and Si7021 I²C postage stamp boards.
- The Si7022-23-EVB kit contains Si7022 and Si7023 PWM output boards.
- The Si7006-07-EVB kit contains Si7006 and Si7007 low-cost postage stamp boards.
- The Si7050/3/4/5-EVB kits contain the appropriate Si7050, Si7053, Si7054 or Si7055 temperature sensor postage stamp.
- The Si7034 kit contains the Si7034 postage stamp.

Using the Si7013 USB-dongle, the Windows GUI will also support “postage stamp” size boards for the Si7005 first-generation temperature and humidity sensor in a 4x4 mm package (Si7005-EB) as well as the Si7015 pin-compatible upgrade of this part (Si7015-EB).

The Windows* GUI will also support the older version Si7005USB-dongle although not all features of the newer parts can be evaluated in this case.

***Note:** Windows is a registered trademark of Microsoft Corporation in the United States and other countries.



Figure 1. Si7013USB-DONGLE

Si7013USB-DONGLE

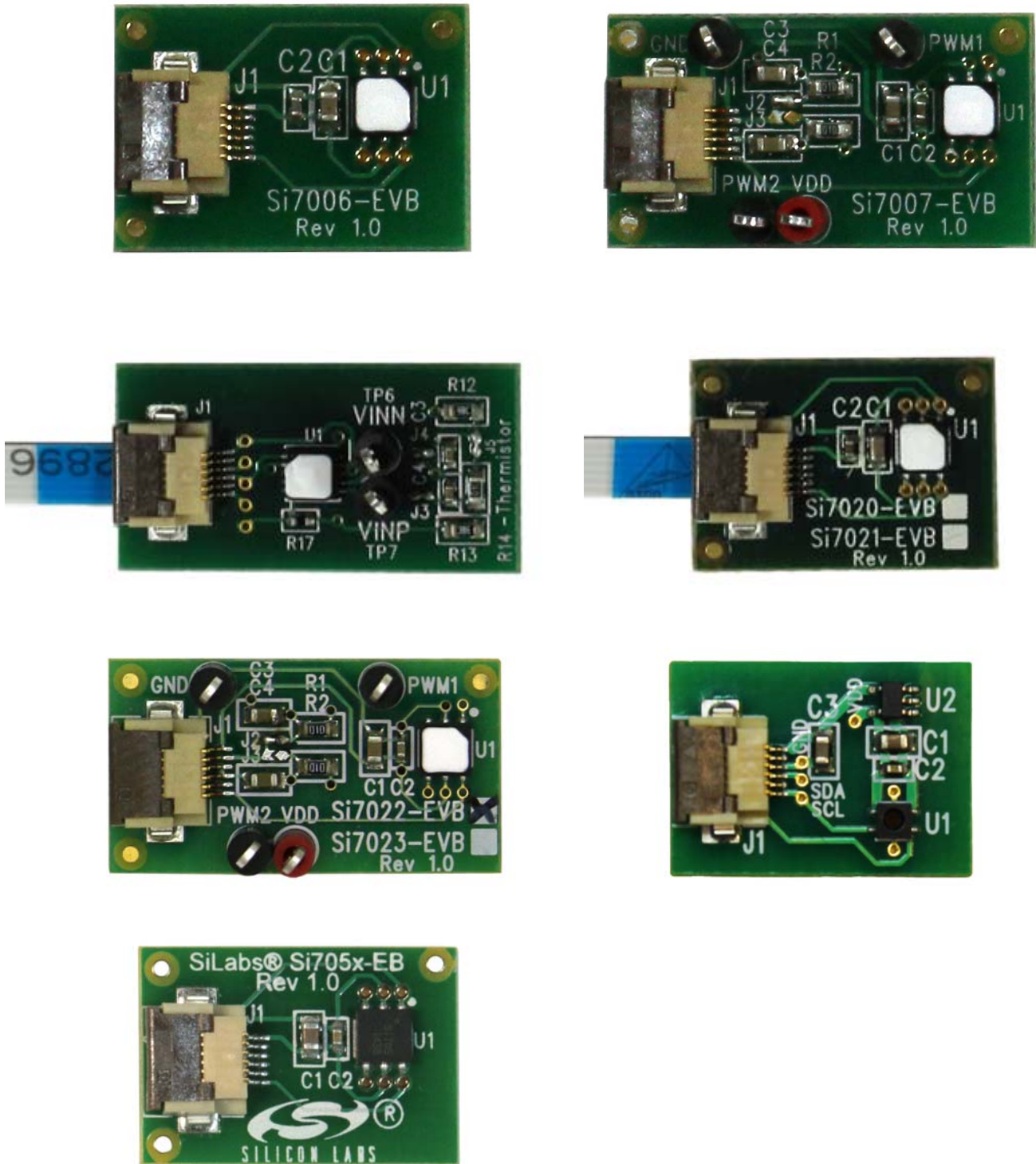

Figure 2. Si7006, Si7007, Si7013, Si7020/21, Si7022/23, Si7034, and Si705x Evaluation Boards

3. Software Setup

It is important that the software be installed before connecting the USB dongle to the PC; this ensures that the software drivers are correctly installed. To set up the software, run the file, setup.exe, from the supplied software installation disk. The Si7013 USB dongle demo platform was developed based on the National Instruments LabView™ platform. To install it, you must accept the National Instruments end-user license agreement shown in Figure 3.



Figure 3. National Instruments Software License Agreement

Si7013USB-DONGLE

Continue through the following screens, which track the Graphical User Interface installation.

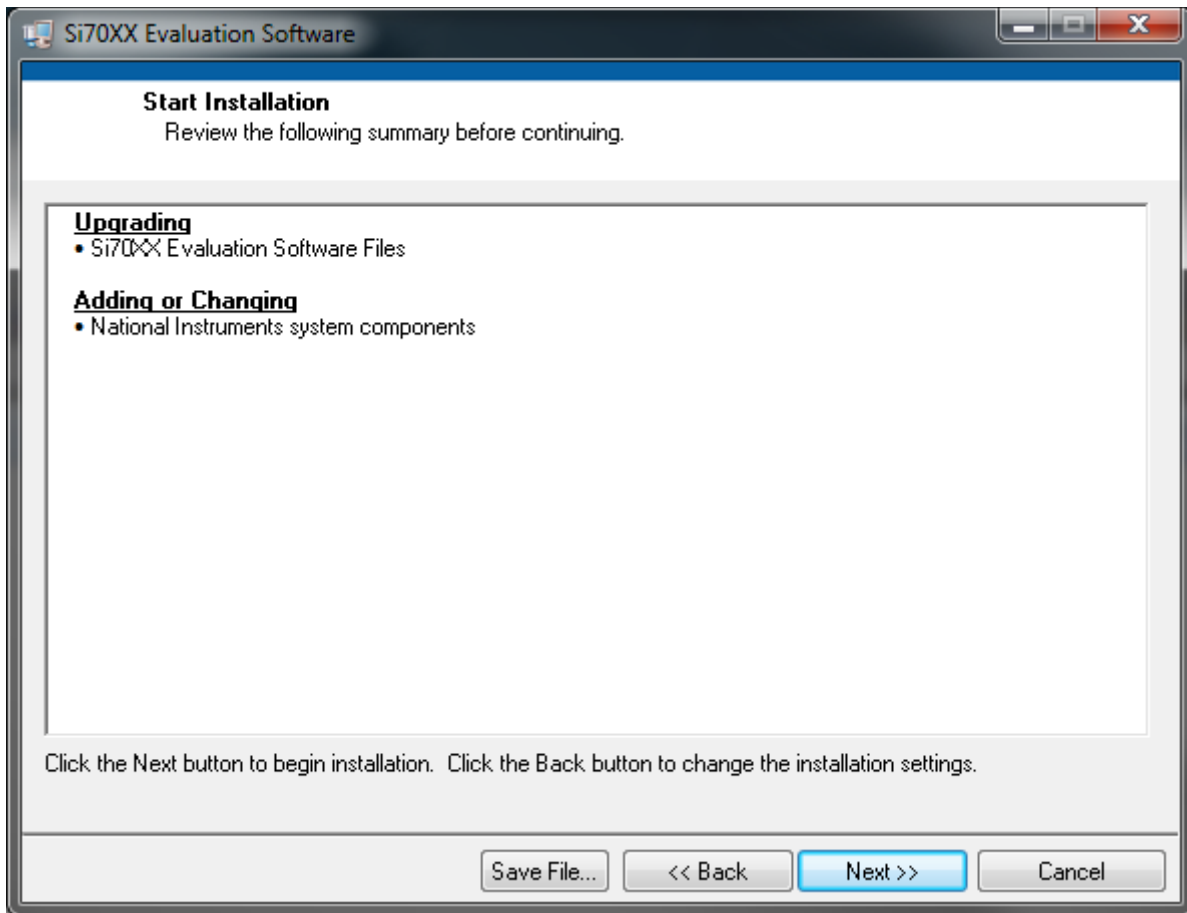

Figure 4. Start Installation Screen

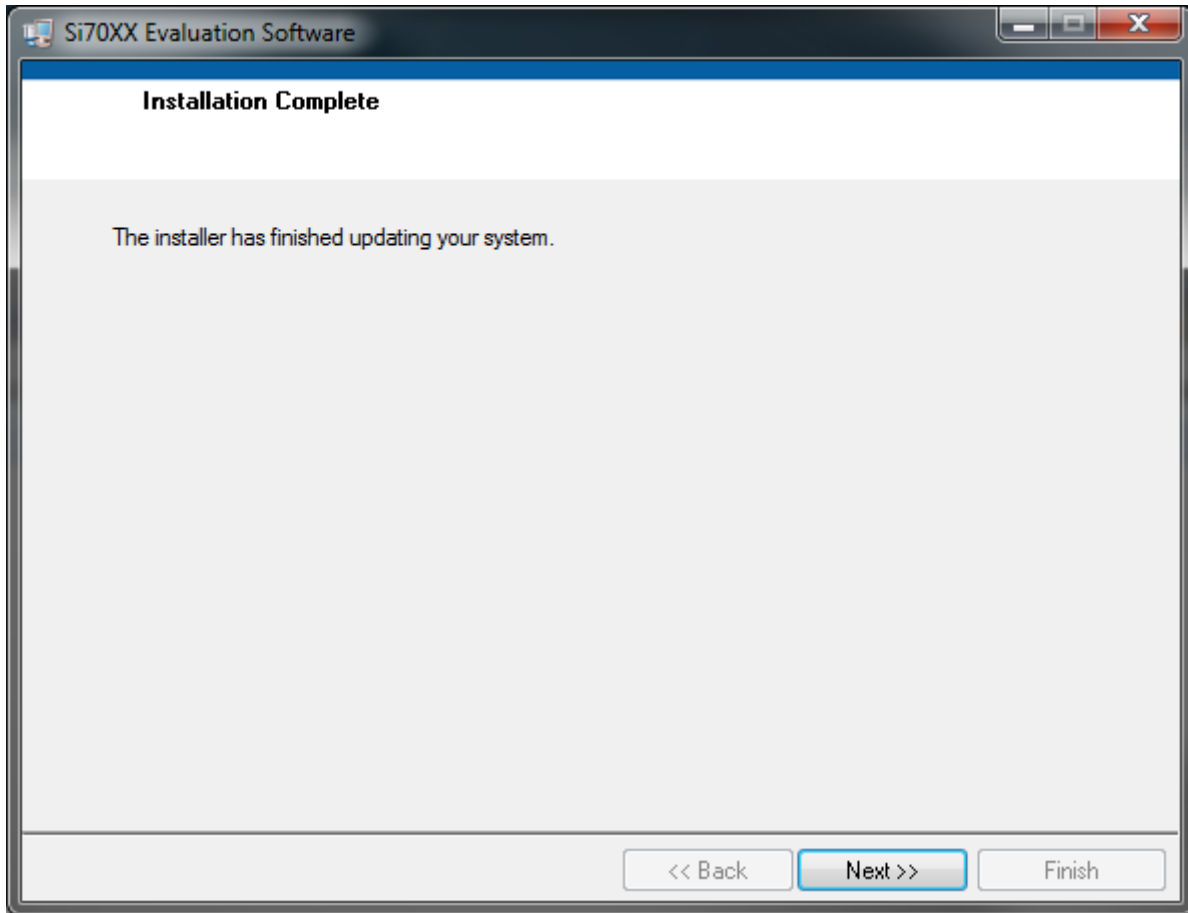

Figure 5. Installer Update Screen

Si7013USB-DONGLE

After this screen, you will see the installer for the Si7013 device drivers.

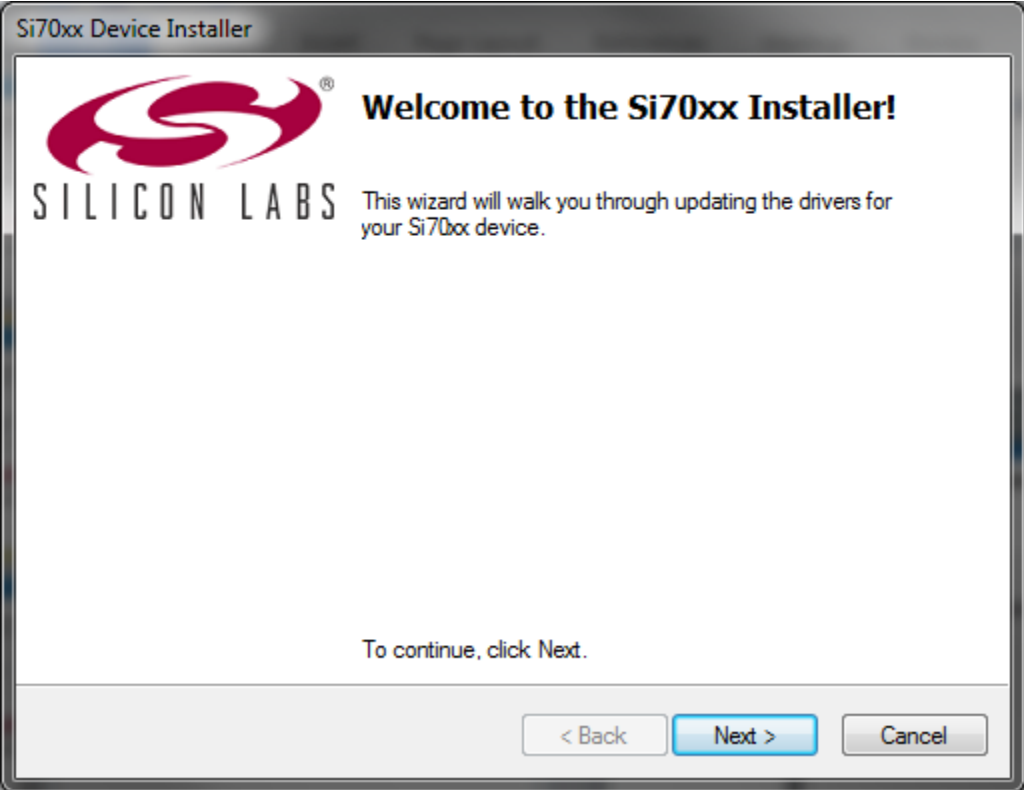

Figure 6. Device Drivers Installer Screen

4. Hardware Setup and Software Operation

Once the GUI installation is complete, connect the Si7013 USB dongle to your PC. Your PC should automatically recognize the USB dongle and use the newly-installed driver. Next, find the icon for the Si7013 GUI, which should be easily found under recently-installed programs from the start menu, under Programs → Silicon Laboratories → Si70xx Evaluation Software or at

C:\Program Files (x86)\Silicon Laboratories\Si70xx

With all the hardware plugged in and once your PC identifies the USB dongle, launch the GUI.

The GUI itself is simple to use. Figure 7 shows a screenshot of the GUI.

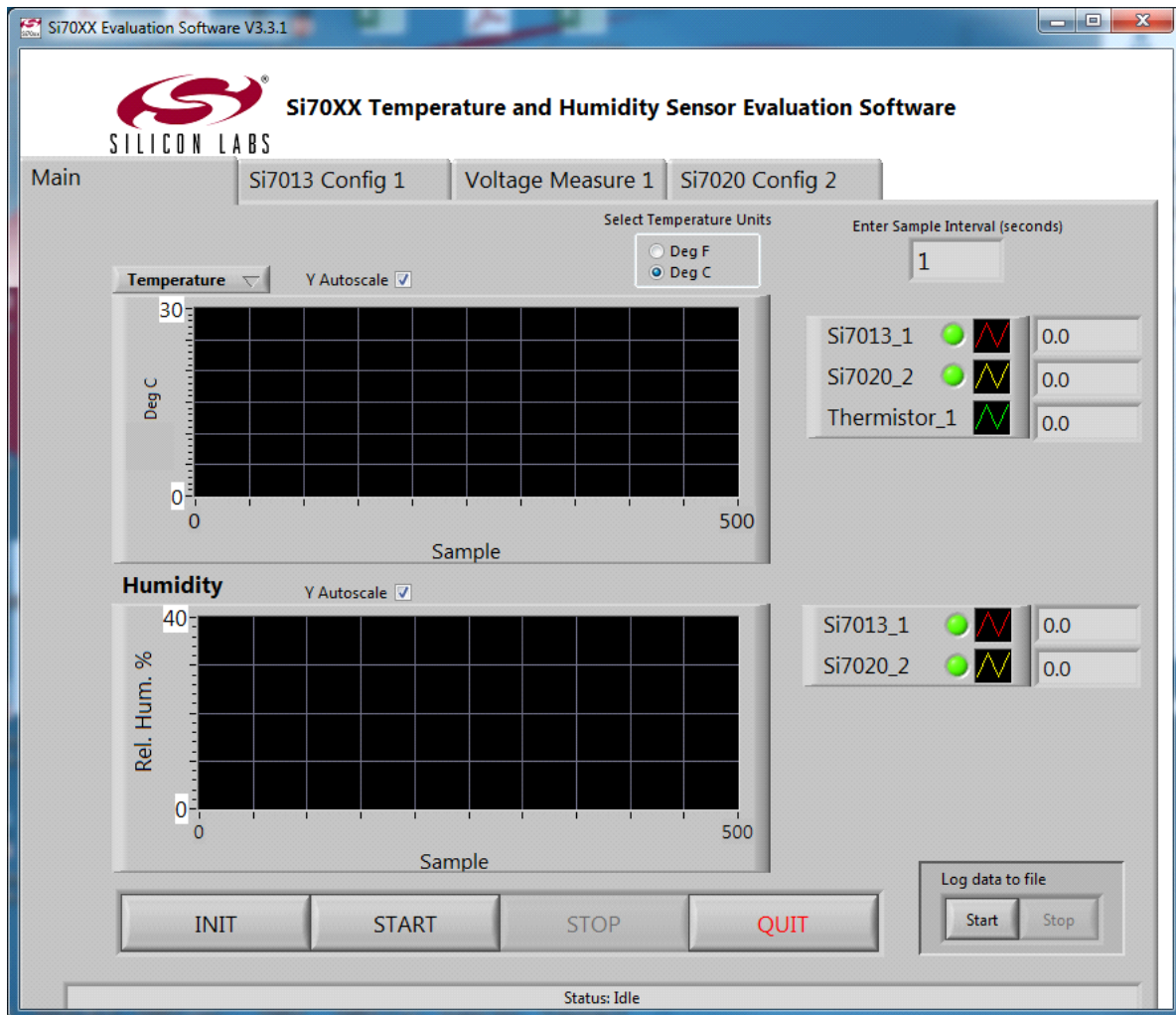

Figure 7. GUI Screen

Note: This is the GUI screen when an additional Si7020-EB is used. The appearance will change according to the number of sensors detected.

The USB dongle contains one Si7013 relative humidity and temperature sensor and can also support one additional sensor at connector J2. All Si70xx sensor evaluation boards are supported.

Note: The "postage stamp" boards are used on this connector with the 3-foot flat flexible cable. To use the cable, carefully lift the darker brown piece of the connector and insert the cable with the metal fingers of the cable facing the metal fingers of the connector then close the connector on the cable (see also figures 1 and 2). If a new postage stamp board is inserted into a powered dongle, click the "INIT" button on the GUI.

Si7013USB-DONGLE

When the GUI is started, it will recognize the sensors that are connected. The INIT button should be pressed if the hardware wasn't connected or was changed after the GUI was started. The analog output devices, Si7007, Si7022, and Si7023, do not have a device ID capability. Analog output is "advertised" by shorting the SDA pin of the 6-pin connector low. In these cases the GUI reports "analog output" device because it is not possible to know which device is connected.

Select temperature units by clicking on the "Select Temperature Units" button. The button will toggle between "Deg C" and "Deg F" indicating the selection of either degrees Celsius or degrees Fahrenheit.

In the "Enter Sample Interval (seconds)" number box, the time interval between samples can be entered as any value greater than 0.2 seconds in increments of 0.1 seconds. Depending on the number of devices connected, sample times less than 1 second might not be possible. In this case, the window will turn red and the sample time will be as short as possible.

The upper chart by default displays temperature; this can be changed to dew point by clicking on the selection box located directly under the Silicon Labs logo. The temperature and dew point should always be logged regardless of setting.

The default Y-axis range on each chart auto-ranges. If desired, the auto-ranging can be turned off and the upper and lower limits for the charts can be set by clicking on the appropriate box. The same configuration changes can be made to the X-axis.

If a log of the data is desired, click "START" inside the "Log Data to File" box to begin collecting data. If "Create Log File?" is enabled, a dialog box will appear requesting a file name and save location. The time base of the log file can be chosen to be absolute date and time or relative time in seconds. To stop data collection, click "STOP". To exit the GUI click "QUIT".

If an Si7005 or Si7015 evaluation board is connected, the GUI automatically adjusts for the temperature and non-linearity effect of the RH sensor. (This is not required for the other sensors as this is done internally to the part). The data logged to file is saved in comma separated value (csv) format, which can be easily opened in a spreadsheet application such as Microsoft Excel, as shown in Figure 8.

	A	B	C	D	E	F	G	H	I	J	K
1	Date	Time	Temp. (degC)	Temp. (degC)	Rel. Hum. (%)	Dewpoint (degC)	Temp. (degC)	Temp. (degC)	Rel. Hum. (%)	Dewpoint (degC)	
2	7/2/2013	1:20:20 PM	24.44	24.28	47.1	12.42	22.79	23.38	51.5	12.29	
3	7/2/2013	1:20:22 PM	24.45	24.28	47.1	12.44	22.78	23.38	51.5	12.28	
4	7/2/2013	1:20:23 PM	24.45	24.28	47.1	12.44	22.77	23.38	51.5	12.26	
5	7/2/2013	1:20:25 PM	24.45	24.3	47.1	12.44	22.76	23.38	51.5	12.25	
6	7/2/2013	1:20:26 PM	24.45	24.28	47.1	12.43	22.79	23.38	51.5	12.28	
7	7/2/2013	1:20:28 PM	24.46	24.28	47.1	12.44	22.77	23.38	51.5	12.27	
8	7/2/2013	1:20:29 PM	24.43	24.28	47.1	12.41	22.79	23.4	51.5	12.28	
9	7/2/2013	1:20:31 PM	24.43	24.3	47.1	12.41	22.77	23.4	51.5	12.27	
10	7/2/2013	1:20:32 PM	24.47	24.28	47.1	12.46	22.79	23.4	51.5	12.29	
11	7/2/2013	1:20:34 PM	24.48	24.32	47.1	12.46	22.8	23.4	51.6	12.3	
12	7/2/2013	1:20:35 PM	24.44	24.3	47.1	12.43	23.1	25.44	52.1	12.65	
13	7/2/2013	1:20:37 PM	24.42	24.3	47.1	12.41	24.1	24.84	54.1	14.24	
14	7/2/2013	1:20:38 PM	24.46	24.32	47.1	12.45	23.58	24.8	56.2	14.35	
15	7/2/2013	1:20:40 PM	24.44	24.32	47.1	12.43	23.41	23.82	58.4	14.8	
16	7/2/2013	1:20:41 PM	24.47	24.32	47.1	12.46	23.32	23.82	60.7	15.3	
17	7/2/2013	1:20:43 PM	24.48	24.32	47.1	12.48	23.35	23.76	62.6	15.8	
18	7/2/2013	1:20:44 PM	24.47	24.32	47.1	12.46	23.26	23.76	63.9	16.5	
19	7/2/2013	1:20:45 PM	24.46	24.32	47.1	12.46	23.26	23.76	64.2	16.34	

Figure 8. Logged Data Displayed in Excel with Absolute Date and Time Base

4.1. Configuration Screen

The configuration screen displays the configuration settings for the device that is connected.

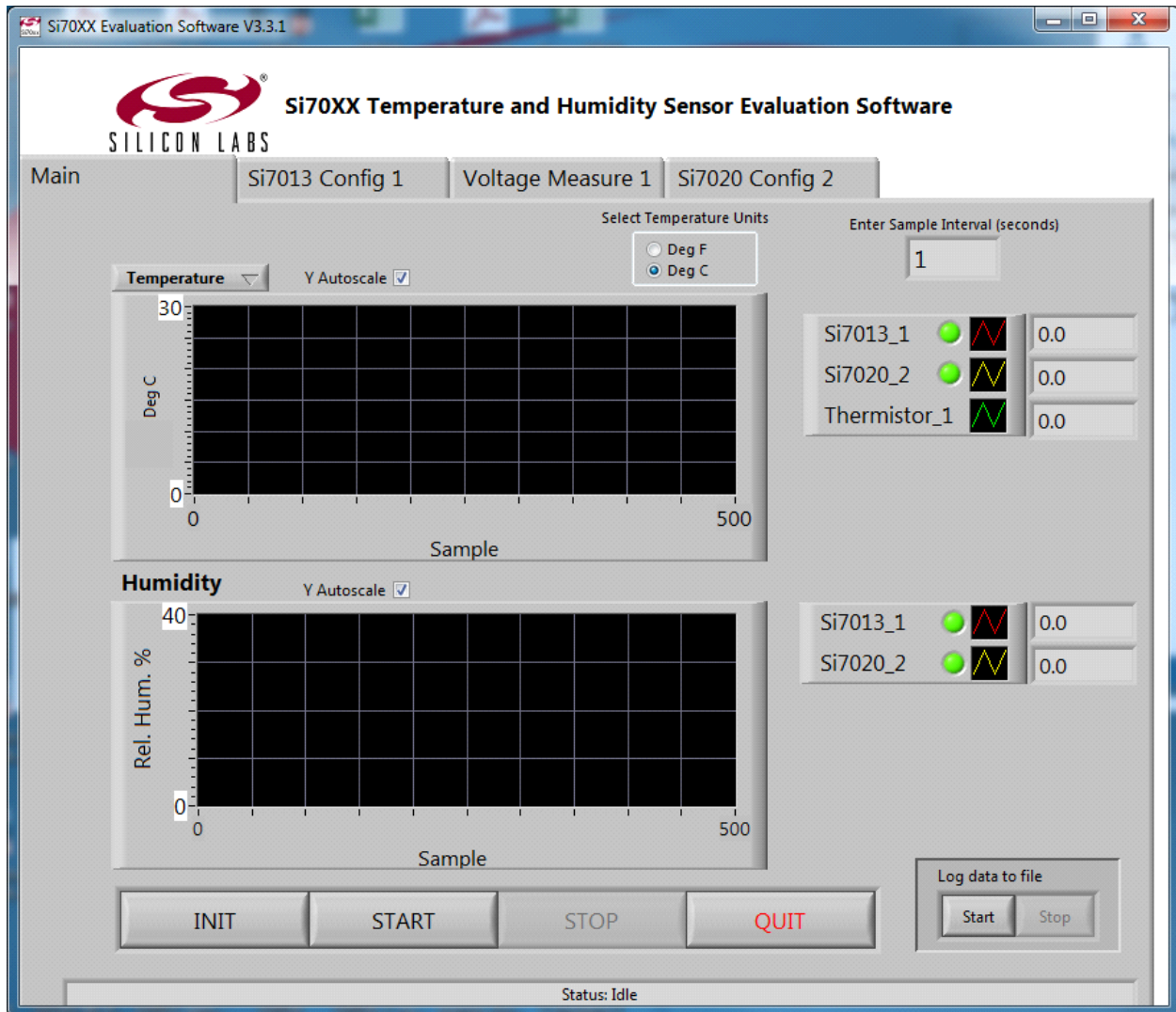

Figure 9. Configuration Screen

For Si7013, this includes:

- The device ID information (an 8-byte identification that is unique to each device)
- Configuration and enable settings for the on-chip heater. While the on-chip heater can go as high as 94 mA, the GUI only supports 39 mA maximum to avoid drawing too much power from the USB port.
- Conversion speed settings for the RH and temperature sensor
- Control of the voltage conversion settings (Si7013 user register 2)

An option to disable the Si7013 on the USB dongle is included for the case where the device connected to J2 is of more interest.

Si7013USB-DONGLE

4.2. Voltage Measurement Screen

The voltage measurement screen configures the lookup table based on linearization of analog measurements for Si7013. This is discussed in more detail in the Si7013 data sheet and also in AN607.

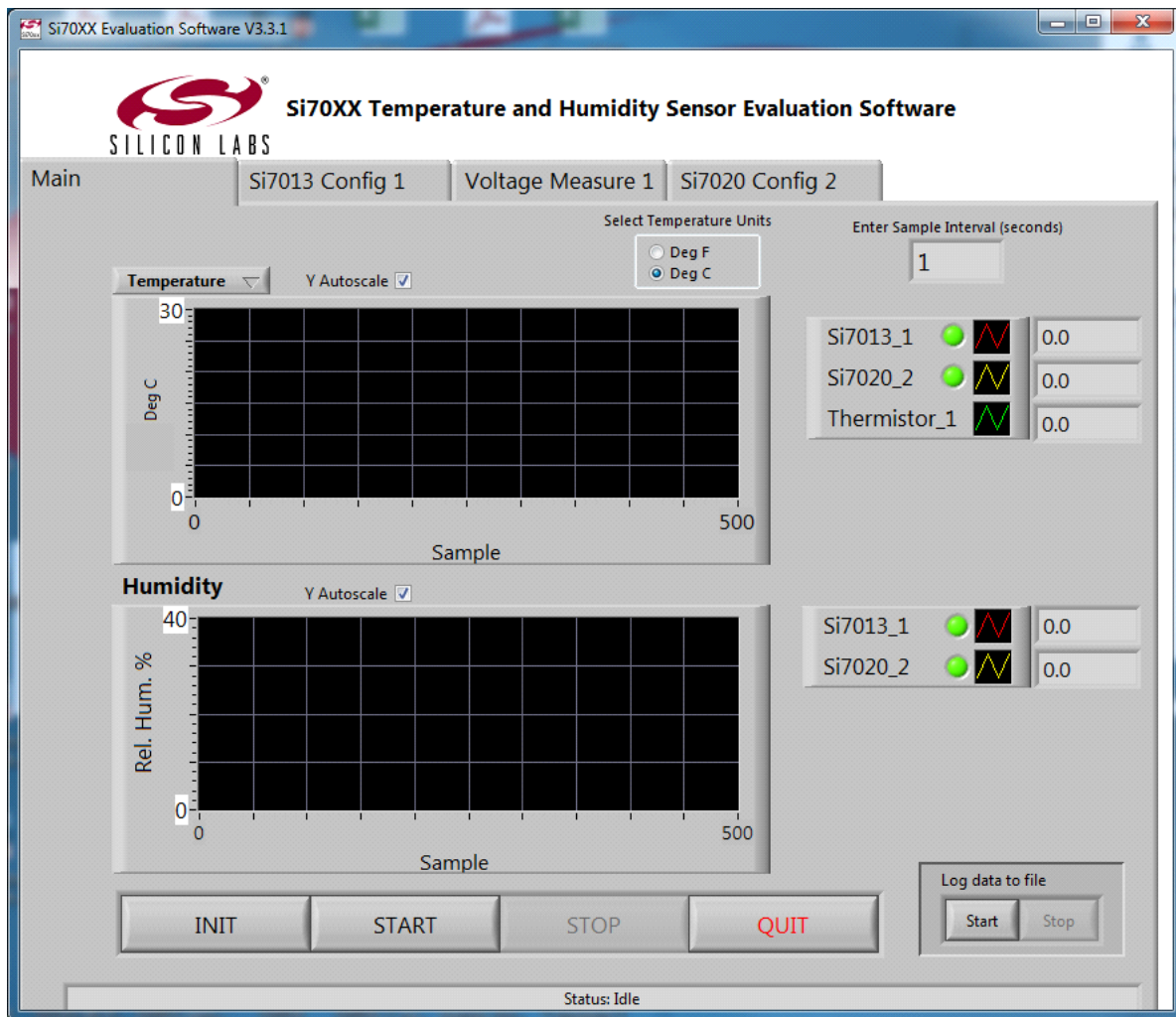

Figure 10. Voltage Measurement Screen

The graph and output window in the upper section of this page shows the measurement result. The graph can be configured as in the previous discussion of graphs on the main page.

By default, the linearization is configured to support the NCP18XH103F03RB thermistor with 24.3 k Ω bias resistors supplied on the evaluation board. The lookup table is chosen so that the linearization results in an output code that is linear with temperature and scaled in the same way as the temperature sensor internal to the Si7013.

If the linearization coefficients have not been written to the Si7013 part the lookup table entries are applied by the GUI and the resultant linearized (temperature) output can be graphed on the main page. In this case the coefficients can be modified to try different lookup tables. Prior to writing the coefficients to the Si7013, the coefficients in the GUI entry boxes can be saved and later loaded. (They are saved to the file Si7013.ini in the directory where the GUI executable is located).

Clicking the Program coefficients button writes the coefficients to the part. This is a one-time process. After doing the write, close the GUI and cycle power. After doing this, the internal correction can be enabled on the configuration screen (lower right) and when enabled the corrected data will be displayed on the measurement screen as well as the main screen (if enabled).

4.3. Calculation of Dew Point Value

The Si7013 measures both temperature (T) and relative humidity (RH). These two values can be used to approximate the dew point (Td).

$$T_d = \frac{b\gamma(T,RH)}{a - \gamma(T,RH)}$$

Where

$$\gamma(T,RH) = \frac{aT}{b + T} + \ln\left(\frac{RH}{100}\right)$$

$$a = 17.625$$

$$b = 243.04$$

The calculation used is based on the August-Roche-Magnus approximation for the saturation vapor pressure of water in air as a function of temperature, it is considered valid for:

$$0\text{ }^{\circ}\text{C} < T < 60\text{ }^{\circ}\text{C}$$

$$1\% < RH < 100\%$$

$$0\text{ }^{\circ}\text{C} < T_d < 50\text{ }^{\circ}\text{C}$$

Si7013USB-DONGLE

5. Si7013 USB Dongle Description

The USB dongle facilitates communication between the Si7013 and the optional postage stamp size evaluation board and a PC. This function is enabled by the Silicon Laboratories' C8051F381 microcontroller. The optional postage stamp board is connected to connector J2 by a 6 wire flat flexible cable. The pin connections for connector J2 are shown in Figure 10. A full circuit diagram of the board is shown in Figure 11.

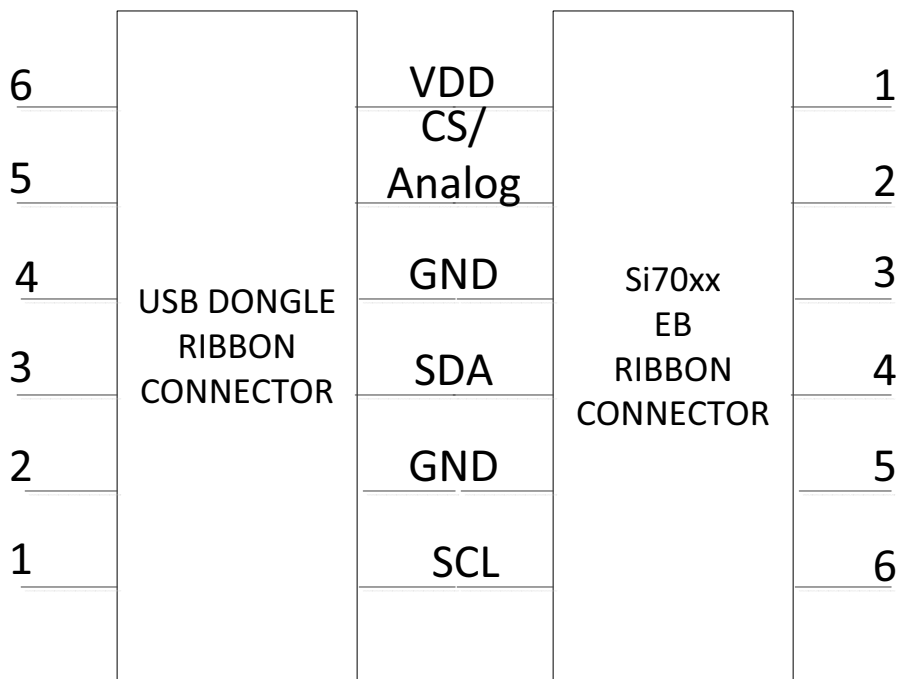

Figure 11. Ribbon Cable Pin Assignments

5.1. Si7013 USB Dongle Schematic

The Si7013 USB-DONGLE is a simple board that contains a Si7013 relative humidity and temperature sensor, a C8051F381 USB microcontroller, a USB type A connector, and an auxiliary connector for connection to a second sensor. There is also support for a thermistor or other analog input. The thermistor and bias circuitry is connected by J3, J4, and J5 which are small solder bridges. To disconnect the thermistor and use the analog input directly (TP6 and TP7), simply use a soldering iron to remove the solder bridges on J3 and J4. Solder wick may aid in removing the bridge, but is usually not required.

Si7013USB-DONGLE

5.2. Si7013 USB Dongle Board Layers

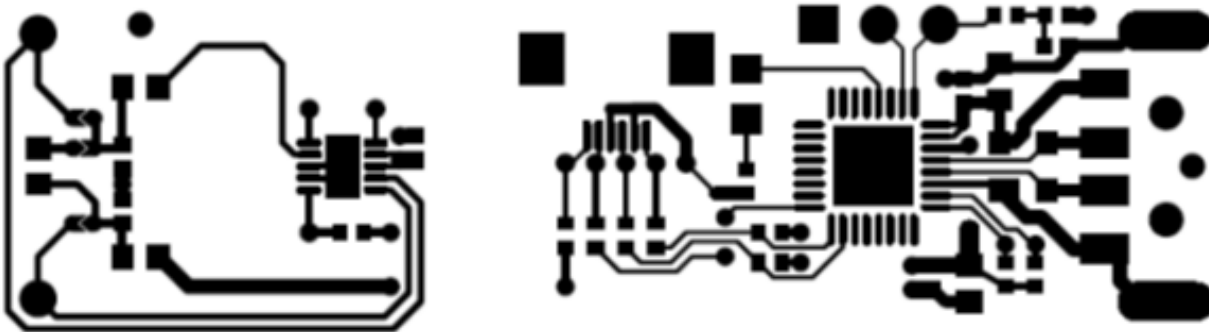

Figure 13. Si7013 Dongle Board Layout Top Layer

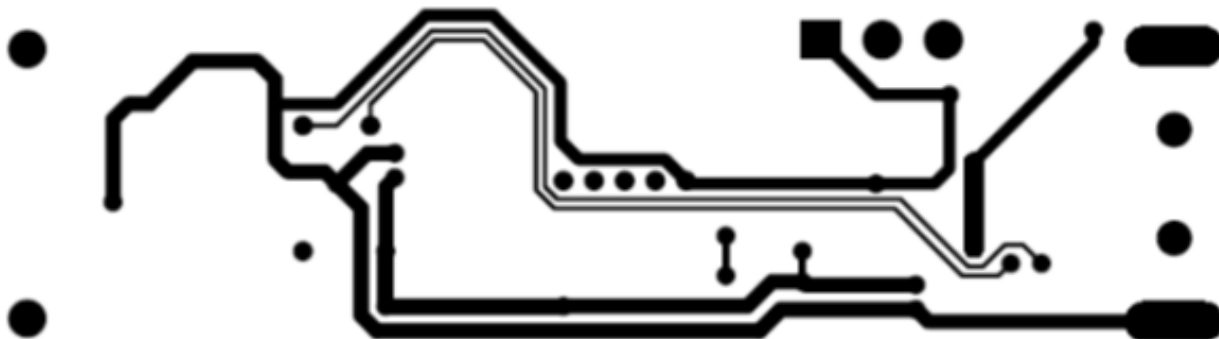

Figure 14. Si7013 Dongle Board Layout Bottom Layer

Note from Figures 15 and 16 that there is no ground plane around the Si7013 and that there is a cutout in the PCB between the Si7013 and other circuitry. While these are not requirements for successful operation of the Si7013, they do (in the case of the dongle board) provide thermal isolation from heat sources, such as the host PC and MCU circuitry. There is also a second thermal cutout to provide isolation between the thermistor and Si7013.

5.3. Si7013 USB Dongle Board Firmware

For board firmware revisions less than 3, when using the Si7013 dongle board at the end of the USB extension cable, **there will be approximately 0.8 °C of heating from the USB MCU despite the use of the thermal cutouts. This amount of heating will reduce the local humidity in the vicinity of the Si7013 by as much as 4%** (the error linearly increases from zero to 4% as the ambient humidity increases from zero to 100%). For more accurate determination of the humidity, the optional “postage stamp” size evaluation boards can be used. For board revision 3 or greater, the heating has been reduced to about 0.2 °C and can usually be ignored. Firmware revision 3 is required for the analog output boards. If the MCU senses SDA is tied low it assumes the board is analog output. Boards with firmware revision 3 or higher have a sticker to indicate this. An easy way to be sure of the board firmware revision is that the LED is constantly on after the GUI recognizes the board for older firmware revisions but only blinks when there is USB activity for newer firmware revisions.

6. Optional “Postage Stamp” Evaluation Boards

6.1. Si7013 EB Schematic

The evaluation board is a simple board containing just the Si7013 sensor, decoupling capacitors, thermistor interface, and a ribbon connector for connection to the USB dongle board.

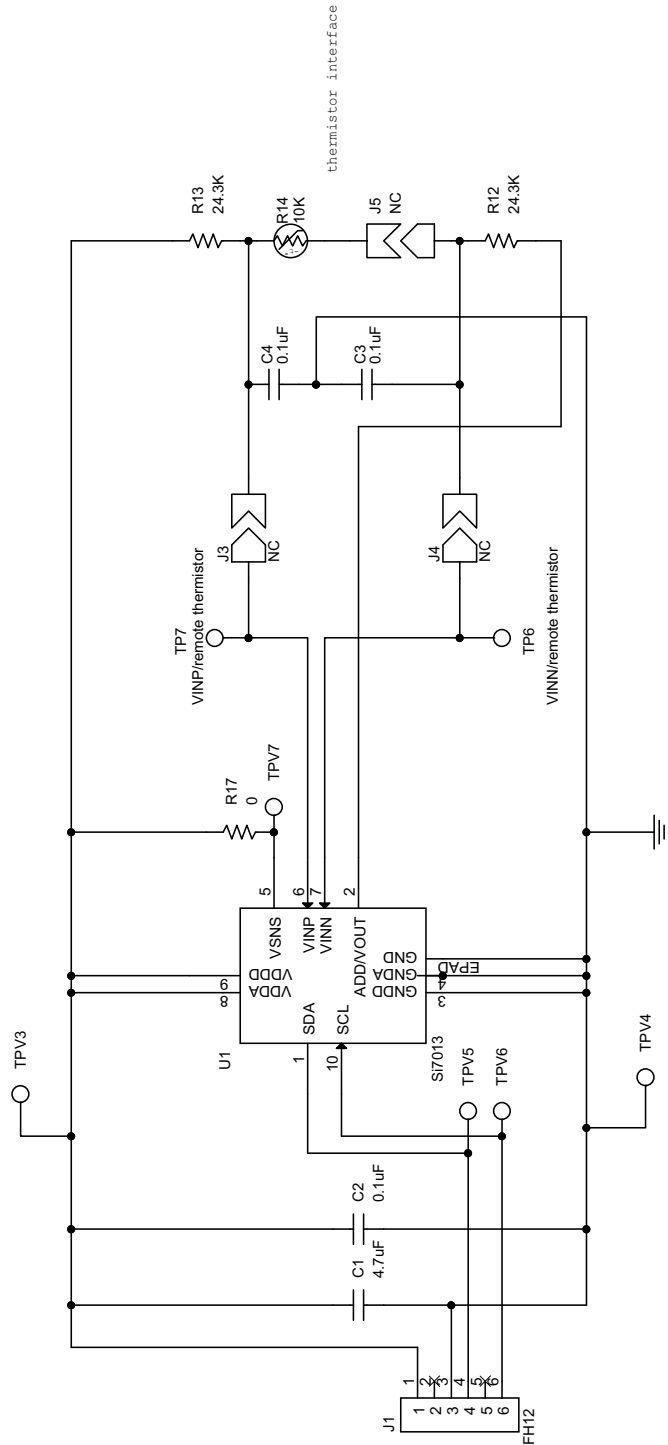

Figure 15. Si7013 EB Schematic

Si7013USB-DONGLE

6.2. Si7006, Si7020/21, or Si7050/3/4/5 EB Schematic

The evaluation board is a simple board containing just the Si7006/20/21/50/53/54 or Si7055, decoupling capacitors and a ribbon connector for connection to the USB dongle board. The populated part number is indicated by a check box on the silkscreen on the top of the PCB.

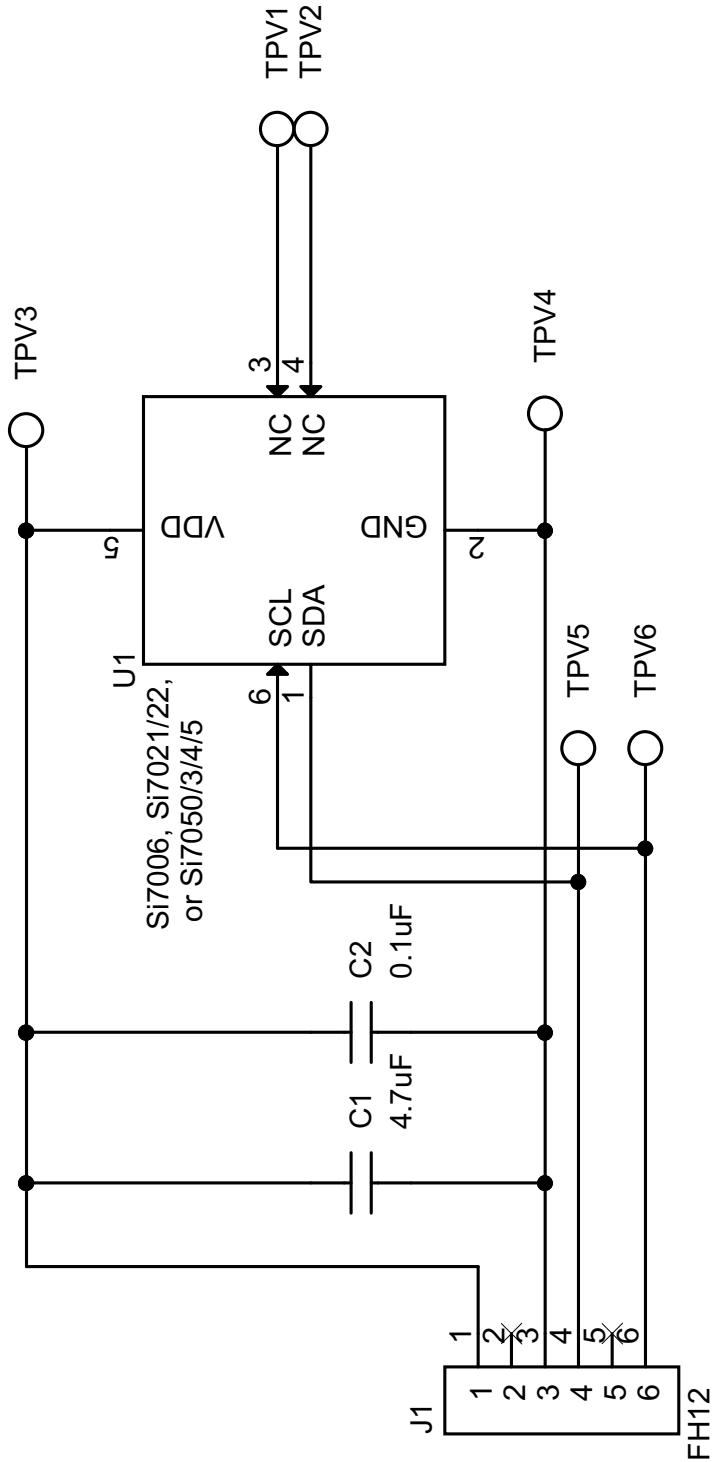

Figure 16. Si7006, Si7020/21, or Si7050/3/4/5 EB Schematic

6.3. Si7005/15 EB Schematic

The evaluation board is a simple board containing just the Si7005 or Si7015 sensor, decoupling capacitors and a ribbon connector for connection to the USB dongle board. The part number is populated and indicated by a check box.

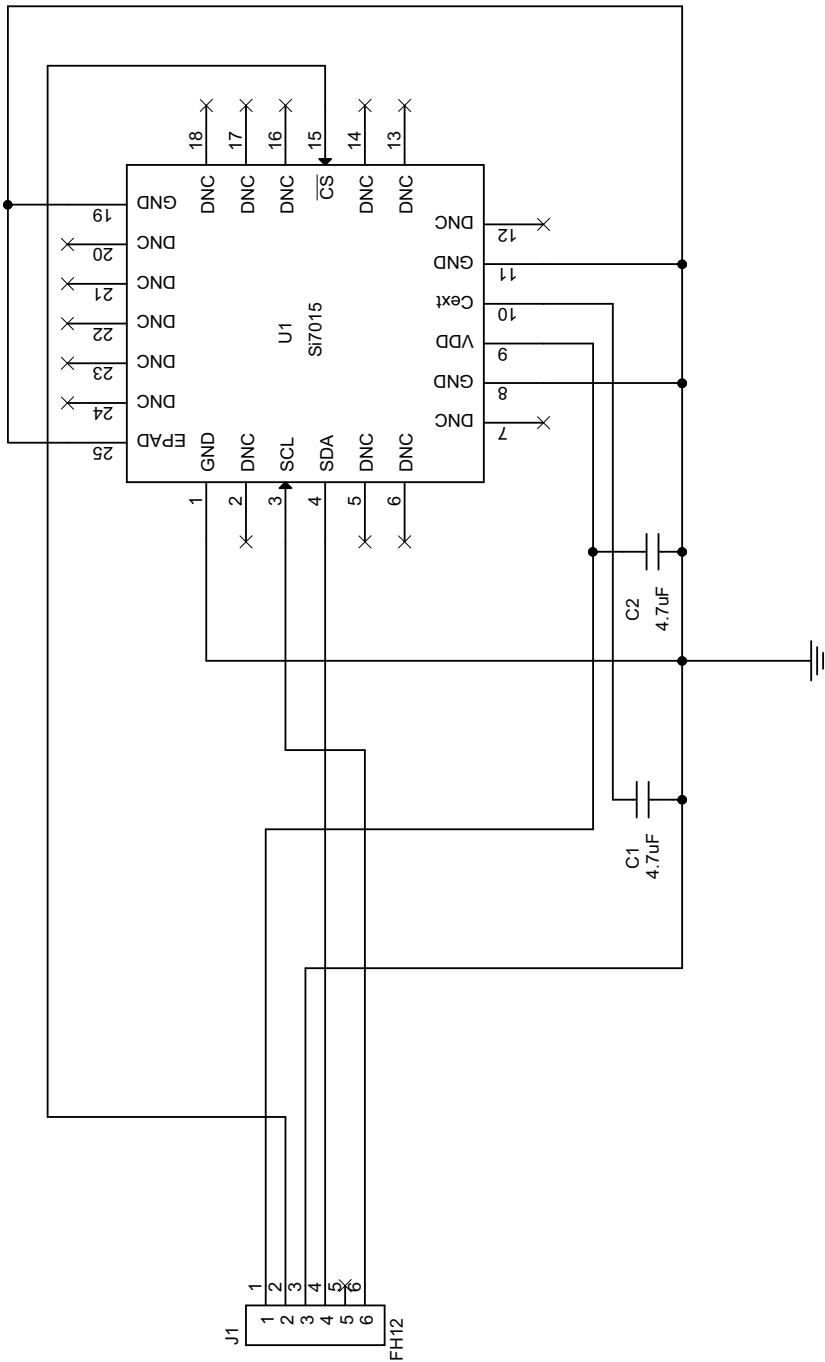

Figure 17. Si7005/15 EB Schematic

7. Additional Reference Resources

- Si7005/6/7/13/15/20/21/22/23/34/50/53/54/55 data sheets
- AN607: Si70xx Humidity Sensor Designer's Guide

8. GUI Revision Notes

- As explained in section “5. Si7013 USB Dongle Description”, firmware Revision 3 of the USB adapter board reduces self-heating of the USB board.
- GUI Revision 3.3.0
 - Corrects a minor problem in the data logging which resulted in small output fluctuations that were not “real.”
 - Adds support for disabling the device in the USB dongle.
 - Improves the timing accuracy for the sampling interval.
 - Adds support for other heater current settings for Si7020 and Si7021.
 - Allows removal of individual graphs by clicking the green radar button for that graph.
- GUI Revision 4.0
 - Adds support for the Si705x temperature sensors. GUI revision 4.0 also includes support for the Si7034.

DOCUMENT CHANGE LIST

Revision 0.1 to Revision 0.2

- Updated "2. Evaluation Kit Descriptions" on page 1.
 - Added Si7020-EB "postage stamp" size evaluation board for the Si7020.

Revision 0.2 to Revision 0.4

- Updated "4. Hardware Setup and Software Operation" on page 7.
- Updated Figure 7, "GUI Screen," on page 7.
- Updated "4.1. Configuration Screen" on page 9.
- Updated Figure 9, "Configuration Screen," on page 9.
- Updated Figure 10, "Voltage Measurement Screen," on page 10.
- Updated "5.2. Si7013 USB Dongle Board Layers" on page 14.
- Added "8. GUI Revision Notes" on page 20.

Revision 0.4 to Revision 0.5

- Updated "1. Introduction" on page 1.
- Updated "2. Evaluation Kit Descriptions" on page 1.
- Updated "3. Software Setup" on page 3.
- Updated "4. Hardware Setup and Software Operation" on page 7.
- Updated "5. Si7013 USB Dongle Description" on page 12.
- Updated "5.2. Si7013 USB Dongle Board Layers" on page 14.
- Updated "6.2. Si7006, Si7020/21, or Si7050/3/4/5 EB Schematic" on page 16.
- Added "6.4. Si7007, Si7022, and Si7023 EVB Schematic" on page 18.

Revision 0.5 to Revision 0.6

- Added support for the Si705x temperature sensors.

Revision 0.6 to Revision 0.7

- Added support for Si7034.

Si7013USB-DONGLE

CONTACT INFORMATION

Silicon Laboratories Inc.
400 West Cesar Chavez
Austin, TX 78701
Tel: 1+(512) 416-8500
Fax: 1+(512) 416-9669
Toll Free: 1+(877) 444-3032

Please visit the Silicon Labs Technical Support web page:
<https://www.silabs.com/support/pages/contacttechnicalsupport.aspx>
and register to submit a technical support request.

Patent Notice

Silicon Labs invests in research and development to help our customers differentiate in the market with innovative low-power, small size, analog-intensive mixed-signal solutions. Silicon Labs' extensive patent portfolio is a testament to our unique approach and world-class engineering team.

The information in this document is believed to be accurate in all respects at the time of publication but is subject to change without notice. Silicon Laboratories assumes no responsibility for errors and omissions, and disclaims responsibility for any consequences resulting from the use of information included herein. Additionally, Silicon Laboratories assumes no responsibility for the functioning of undescribed features or parameters. Silicon Laboratories reserves the right to make changes without further notice. Silicon Laboratories makes no warranty, representation or guarantee regarding the suitability of its products for any particular purpose, nor does Silicon Laboratories assume any liability arising out of the application or use of any product or circuit, and specifically disclaims any and all liability, including without limitation consequential or incidental damages. Silicon Laboratories products are not designed, intended, or authorized for use in applications intended to support or sustain life, or for any other application in which the failure of the Silicon Laboratories product could create a situation where personal injury or death may occur. Should Buyer purchase or use Silicon Laboratories products for any such unintended or unauthorized application, Buyer shall indemnify and hold Silicon Laboratories harmless against all claims and damages.

Silicon Laboratories and Silicon Labs are trademarks of Silicon Laboratories Inc.
Other products or brandnames mentioned herein are trademarks or registered trademarks of their respective holders.