



FPF1003A / FPF1004 IntelliMAX™ Advanced Load Management Products

Features

- 1.2 V to 5.5 V Input Voltage Operating Range
- Typical $R_{DS(ON)}$:
 - 30 m Ω at $V_{IN}=5.5$ V
 - 35 m Ω at $V_{IN}=3.3$ V
- ESD Protected: Above 8000 V HBM
- ROHS Compliant

Applications

- PDA's
- Cell Phones
- GPS Devices
- MP3 Players
- Digital Cameras
- Peripheral Ports
- Hot Swap Supplies

Description

The FPF1003A and FPF1004 are low R_{DS} P-channel MOSFET load switches with controlled turn-on. The input voltage range operates from 1.2 V to 5.5 V to fulfill today's ultra-portable device supply requirements. Switch control is accomplished with a logic input (ON) capable of interfacing directly with low-voltage control signal. In FPF1004, a 120 Ω on-chip load resistor is added for output quick discharge when the switch is turned off.

Both FPF1003A and FPF1004 are available in a space-saving 1.0x1.5 mm² wafer-level chip-scale package.

Ordering Information

Part Number	Top Mark	Switch	Input Buffer	Output Discharge	ON Pin Activity	Package
FPF1003A	Q2	30 m Ω , PMOS	Schmitt	NA	Active HIGH	1.0 x 1.5 mm ² Wafer-Level Chip-Scale Package (WLCSP),
FPF1004	Q3			120 Ω	Active HIGH	

Application Diagram

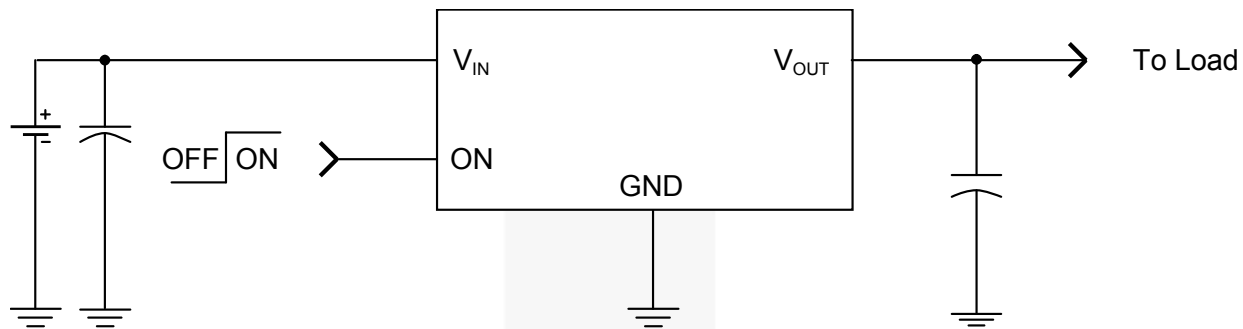

Figure 1. Typical Application

Block Diagram

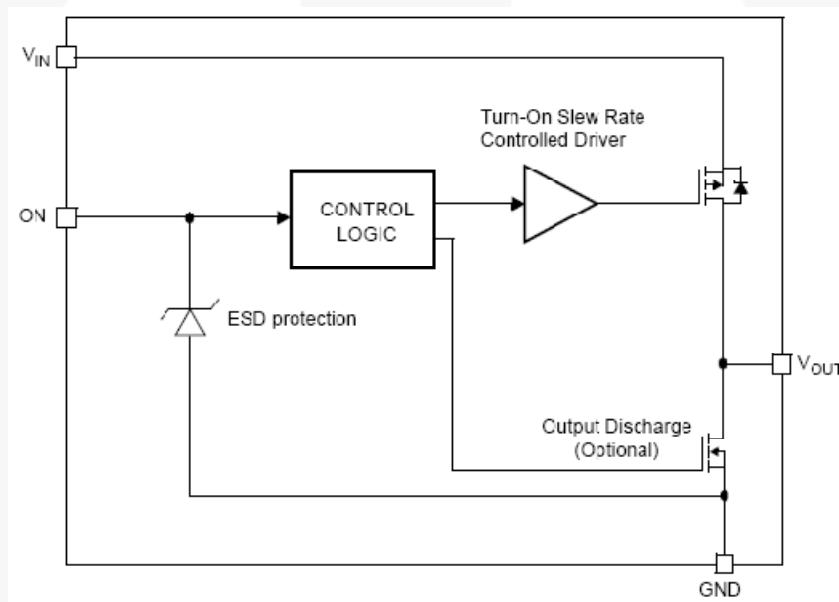

Figure 2. Functional Block Diagram

Pin Configurations

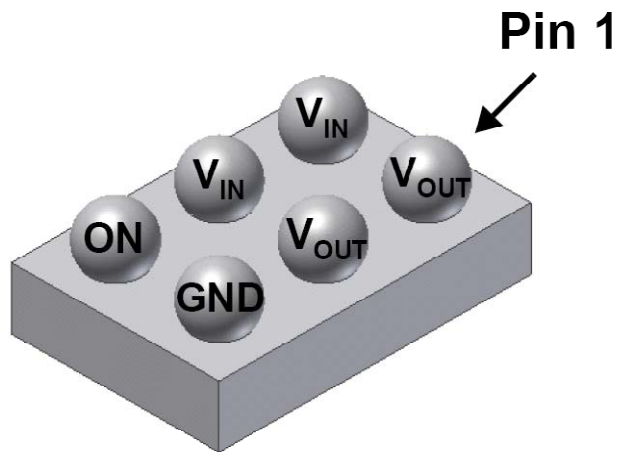

Figure 3. WLCSP Bumps Facing UP

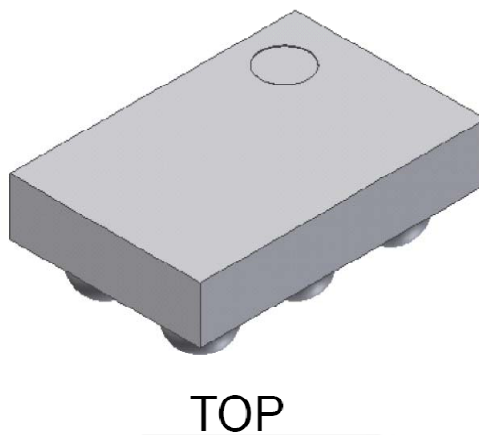

Figure 4. WLCSP Bumps Facing Down

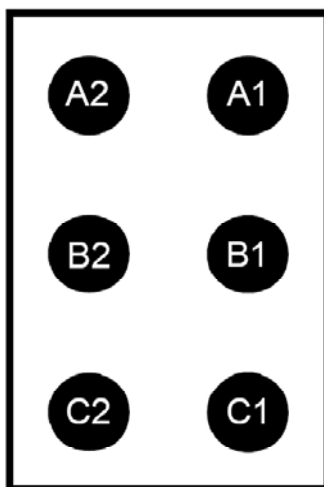

Figure 5. 1.0mm x 1.5mm WLCSP Pin Assignments (Bottom View)

Pin Definitions

Pin #	Name	Description
A2, B2	V_{IN}	Input to the power switch and the supply voltage for the IC
C2	ON	ON Control Input
A1, B1	V_{OUT}	Output of the power switch
C1	GND	Ground

Absolute Maximum Ratings

Stresses exceeding the absolute maximum ratings may damage the device. The device may not function or be operable above the recommended operating conditions and stressing the parts to these levels is not recommended. In addition, extended exposure to stresses above the recommended operating conditions may affect device reliability. The absolute maximum ratings are stress ratings only.

Symbol	Parameter	Min.	Max.	Unit
V_{IN}	V_{IN} , V_{OUT} , ON to GND	-0.3	6.0	V
I_{SW}	Maximum Continuous Switch Current		2.0	A
P_D	Power Dissipation at $T_A=25^\circ\text{C}^{(1)}$		1.2	W
T_{STG}	Storage Junction Temperature	-65	+150	$^\circ\text{C}$
T_A	Operating Temperature Range	-40	+125	$^\circ\text{C}$
Θ_{JA}	Thermal Resistance, Junction-to-Ambient		85	$^\circ\text{C}/\text{W}$
ESD	Electrostatic Discharge Capability	Human Body Model, JESD22-A114	5500	V
		Charged Device Model, JESD22-C101	1500	

Note:

1. Package power dissipation on one square inch pad, 2 oz.

Recommended Operating Conditions

The Recommended Operating Conditions table defines the conditions for actual device operation. Recommended operating conditions are specified to ensure optimal performance to the datasheet specifications. Fairchild does not recommend exceeding them or designing to Absolute Maximum Ratings.

Symbol	Parameter	Min.	Max.	Unit
V_{IN}	Supply Voltage	1.2	5.5	V
T_A	Ambient Operating Temperature	-40	+85	$^\circ\text{C}$

Electrical Characteristics

Unless otherwise noted, $V_{IN}=1.2$ to $5.0V$, $T_A=-40$ to $+85^\circ C$; typical values are at $V_{IN}=3.3V$ and $T_A=25^\circ C$.

Symbol	Parameter	Conditions	Min.	Typ.	Max.	Units
Basic Operation						
V_{IN}	Supply Voltage		1.2		5.5	V
$I_{Q(OFF)}$	Off Supply Current	$V_{ON}=GND$, $OUT=Open$			1	μA
I_{SD}	Shutdown Current	$V_{ON}=GND$, $V_{OUT}=0$ at $V_{IN}=5.5$, $T_A=85^\circ C$			1	μA
		$V_{ON}=GND$, $V_{OUT}=0$ at $V_{IN}=3.3$, $T_A=85^\circ C$		10	100	nA
I_Q	Quiescent Current	$I_{OUT}=0$ mA, $V_{IN}=V_{ON}$			1	μA
R_{ON}	On-Resistance	$V_{IN}=5.5$ V, $I_{OUT}=1$ A, $T_A=25^\circ C$		20	30	m Ω
		$V_{IN}=3.3$ V, $I_{OUT}=1$ A, $T_A=25^\circ C$		25	35	
		$V_{IN}=1.5$ V, $I_{OUT}=1$ A, $T_A=25^\circ C$		50	75	
		$V_{IN}=1.2$ V, $I_{OUT}=1$ A, $T_A=25^\circ C$		95	150	
		$V_{IN}=3.3$ V, $I_{OUT}=1$ A, $T_A=85^\circ C$		30	42	
		$V_{IN}=3.3$ V, $I_{OUT}=1$ A, $T_A=40^\circ C$ to $85^\circ C$	12		42	
R_{PD}	Output Pull-Down Resistance	$V_{IN}=3.3$ V, $V_{ON}=0$ V, $T_A=25^\circ C$, FPF1004		75	120	Ω
V_{IH}	ON Input Logic High Voltage	$V_{IN}=1.2$ V to 5.5 V	2			V
		$V_{IN}=1.2$ V	0.8			
V_{IL}	ON Input Logic Low Voltage	$V_{IN}=2.7$ V to 5.5 V			0.8	V
		$V_{IN}=1.2$ V			0.35	
I_{ON}	ON Input Leakage	$V_{ON}=V_{IN}$ or GND			1	μA
Dynamic Characteristics						
t_{ON}	Turn-On Time	$V_{IN}=3.3$ V, $R_L=500$ Ω , $C_L=0.1$ μF , $T_A=25^\circ C$		13		μs
t_{OFF}	Turn-Off Time	$V_{IN}=3.3$ V, $R_L=500$ Ω , $C_L=0.1$ μF , $T_A=25^\circ C$, FPF1003A		45		μs
		$V_{IN}=3.3$ V, $R_L=500$ Ω , $C_L=0.1$ μF , $R_{L_CHIP}=120$ Ω , $T_A=25^\circ C$, FPF1004		15		
t_R	V_{OUT} Rise Time	$V_{IN}=3.3$ V, $R_L=500$ Ω , $C_L=0.1$ μF , $T_A=25^\circ C$		13		μs
t_F	V_{OUT} Fall Time	$V_{IN}=3.3$ V, $R_L=500$ Ω , $C_L=0.1$ μF , $T_A=25^\circ C$, FPF1003A		113		μs
		$V_{IN}=3.3$ V, $R_L=500$ Ω , $C_L=0.1$ μF , $R_{L_CHIP}=120$ Ω , $T_A=25^\circ C$, FPF1004		10		

Typical Performance Characteristics

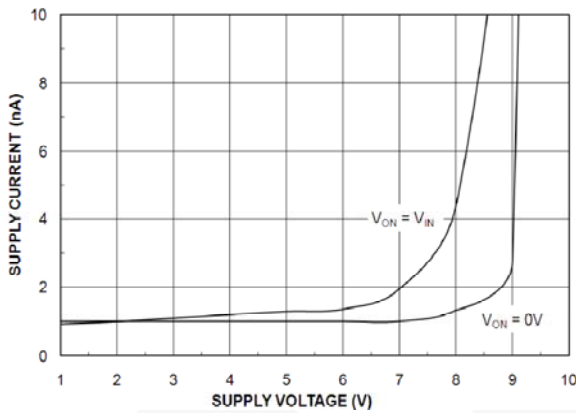

Figure 6. Quiescent Current vs. V_{IN}

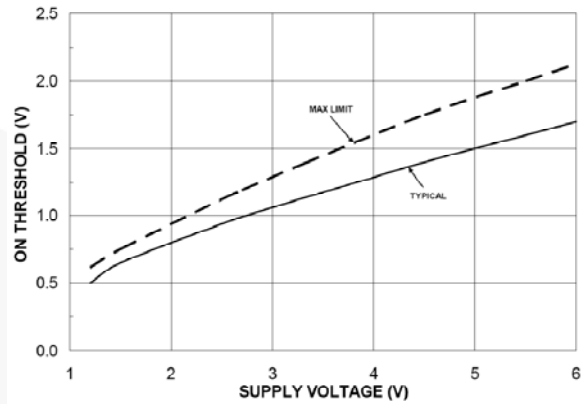

Figure 7. ON Threshold vs. V_{IN}

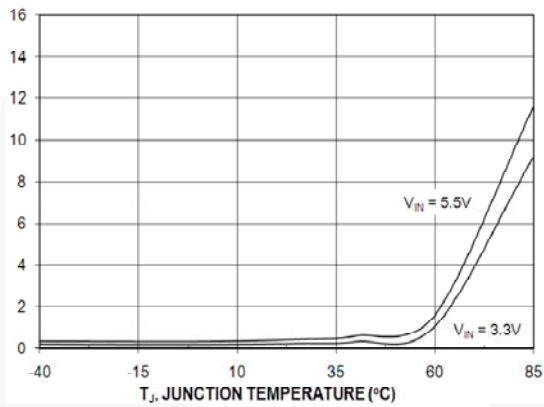

Figure 8. Quiescent Current vs. Temperature

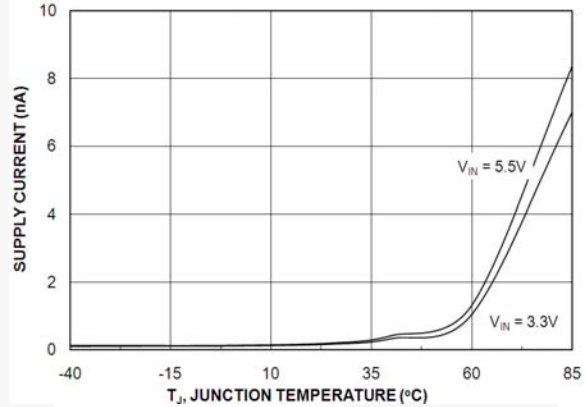

Figure 9. Quiescent Current (OFF) vs. Temperature

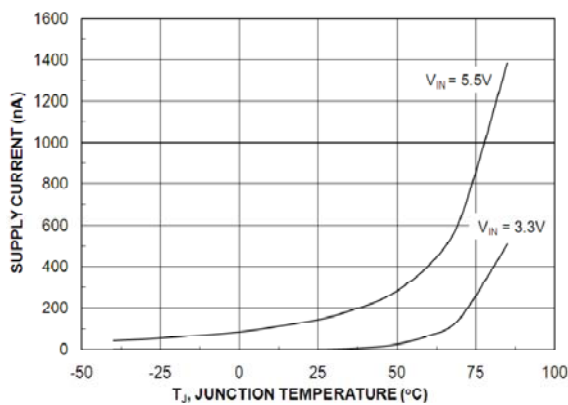

Figure 10. $I_{SWITCH-OFF}$ Current vs. Temperature

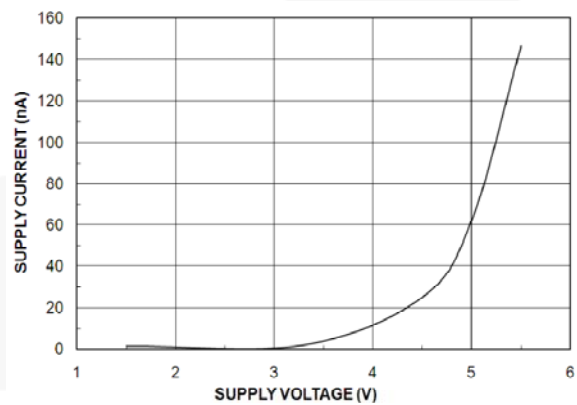

Figure 11. $I_{SWITCH-OFF}$ Current vs. V_{IN}

Typical Performance Characteristics

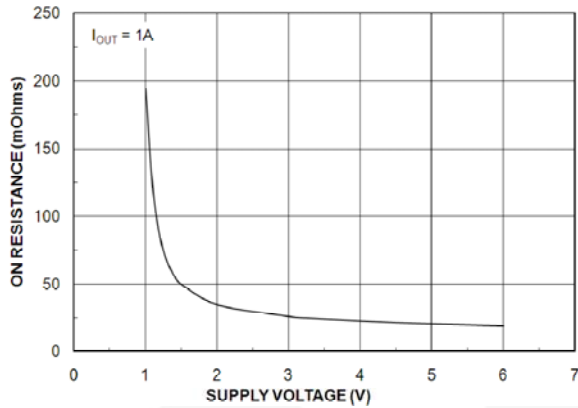

Figure 12. R_{ON} vs. V_{IN}

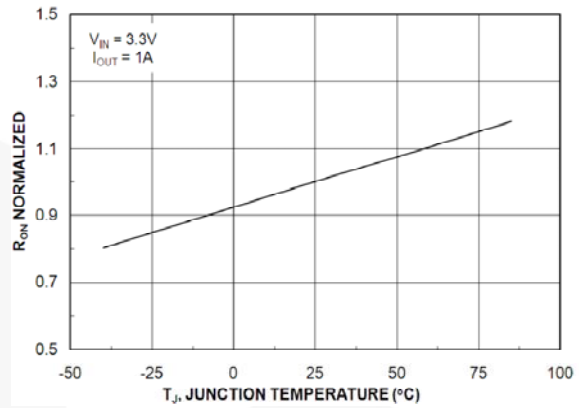

Figure 13. R_{ON} vs. Temperature

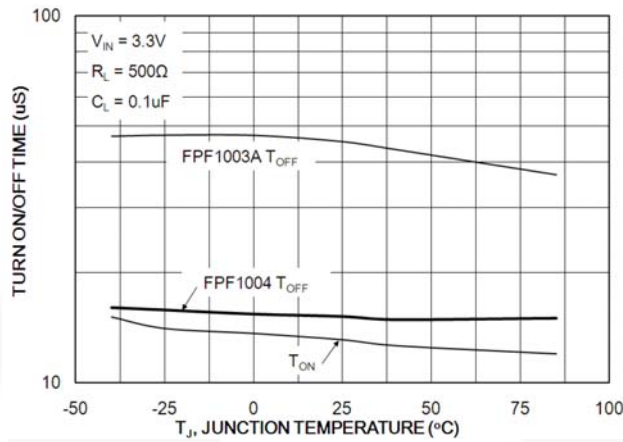

Figure 14. t_{ON}/t_{OFF} vs. Temperature

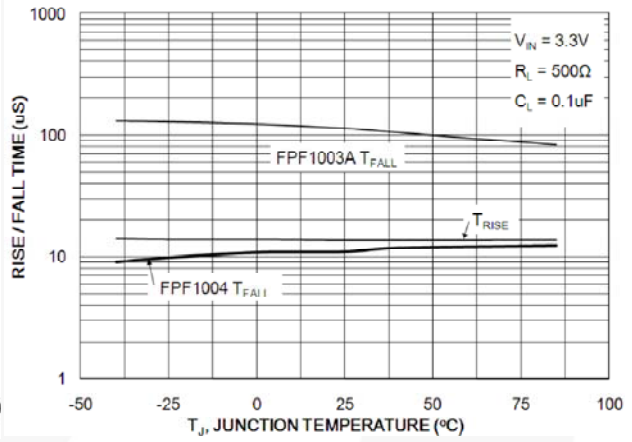

Figure 15. t_R/t_F vs. Temperature

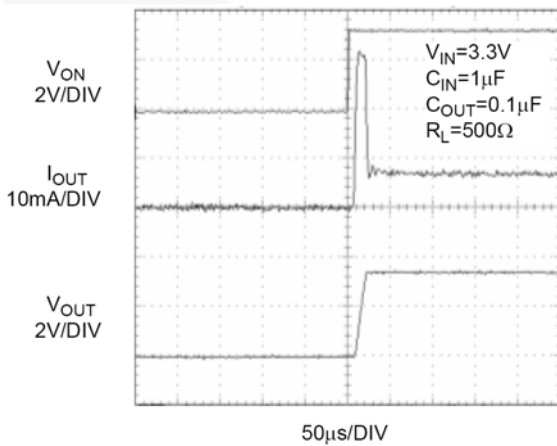

Figure 16. FPF1003A t_{ON} Response

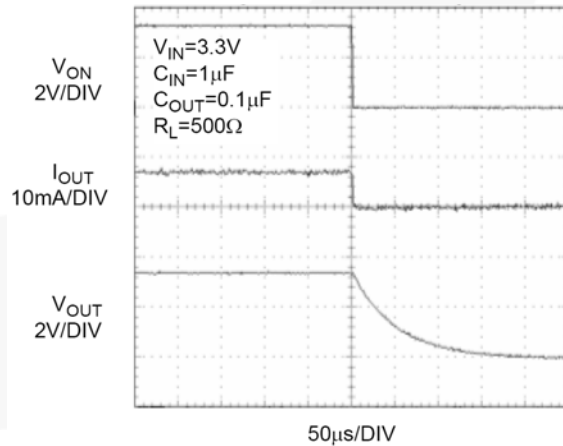

Figure 17. FPF1003A t_{OFF} Response

Typical Performance Characteristics

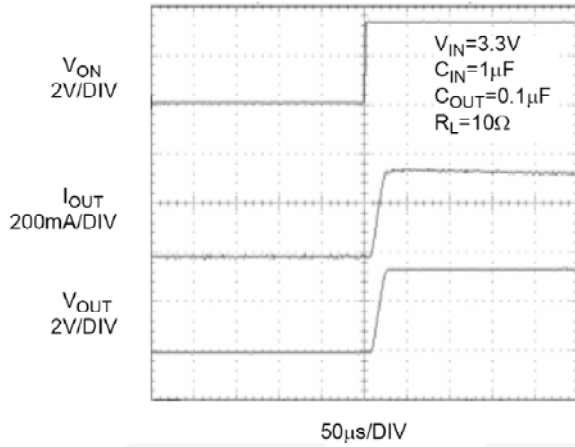

Figure 18. FPF1003A t_{ON} Response

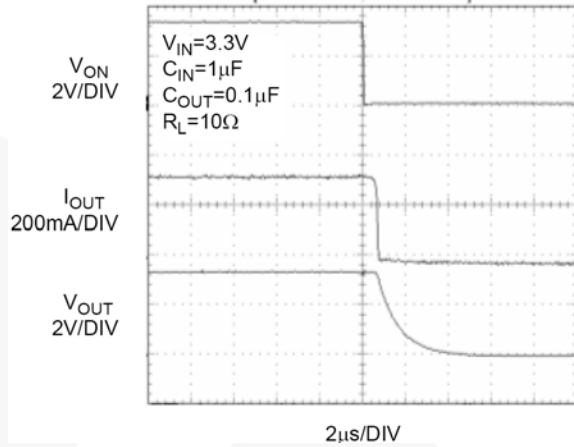

Figure 19. FPF1003A t_{OFF} Response

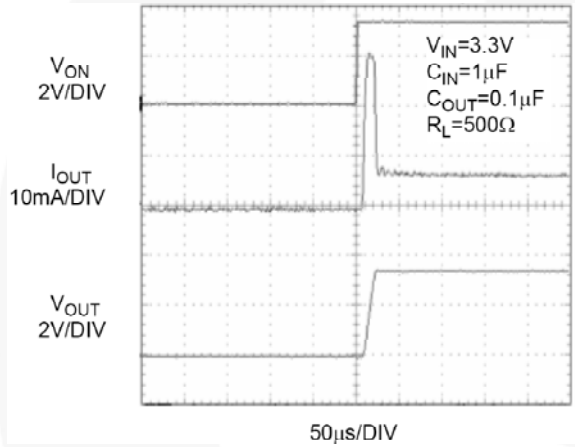

Figure 20. FPF1004 t_{ON} Response

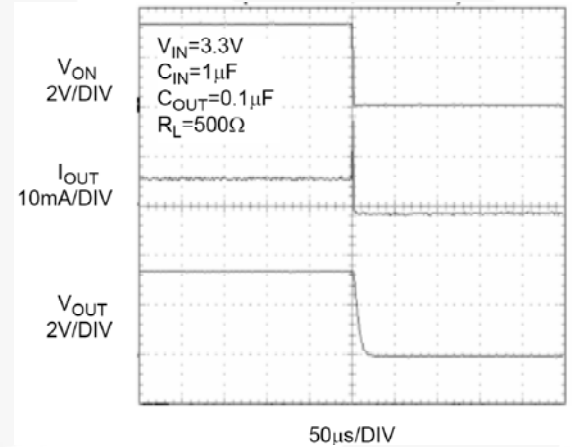

Figure 21. FPF1004 t_{OFF} Response

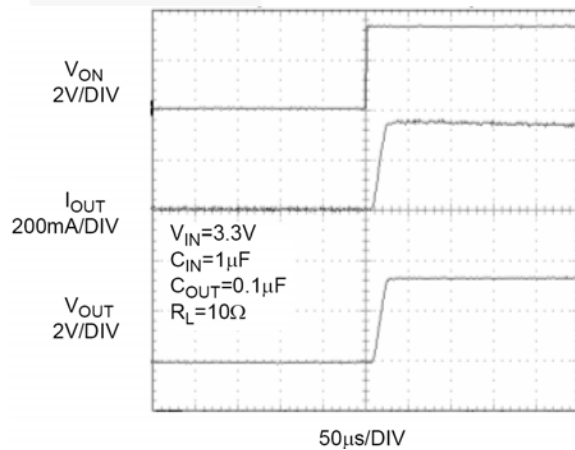

Figure 22. FPF1004 t_{ON} Response

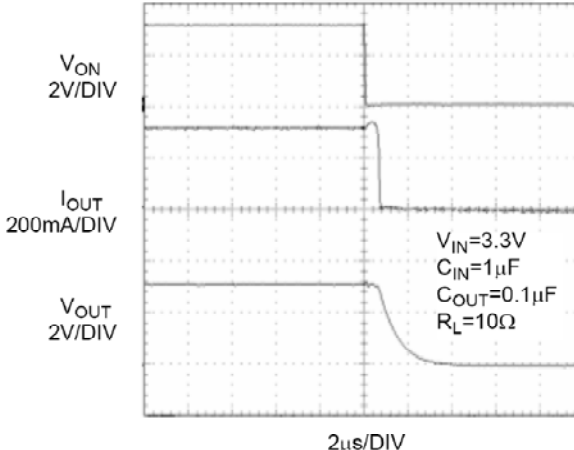

Figure 23. FPF1004 t_{OFF} Response

Description of Operation

Input Capacitor

FPF1003A and FPF1004 are low- $R_{DS(ON)}$ P-channel load switches with controlled turn-on. The core of each device is a 30 m Ω P-Channel MOSFET and a controller capable of functioning over an input operating range of

1.2 to 5.5 V. Switch control is accomplished with a logic input (ON) capable of interfacing directly with low-voltage control signal. In FPF1004, a 120 Ω on-chip load resistor is added for output quick discharge when the switch is turned off.

Application Information

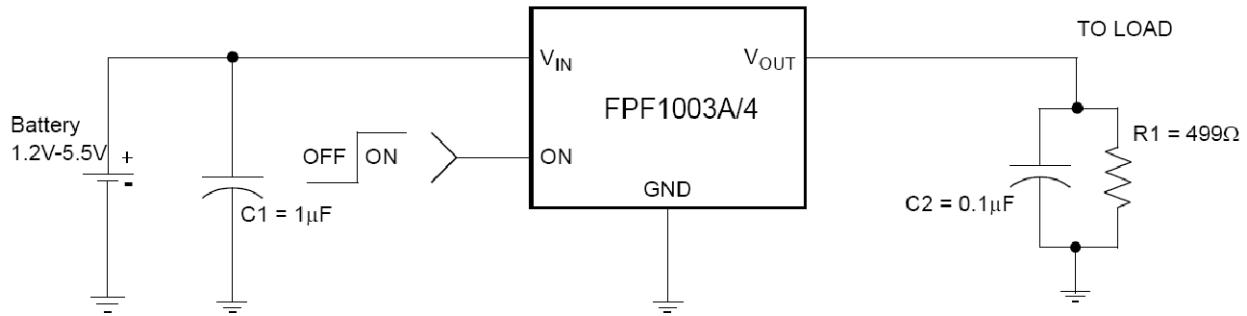

Figure 24. Typical Application

Input Capacitor

To limit the voltage drop on the input supply caused by transient inrush currents when the switch turns on into a discharged load capacitor or short-circuit, a capacitor needs to be placed between V_{IN} and GND. A 0.1 μF ceramic capacitor, C_{IN} , must be placed close to the V_{IN} pin. A higher value of C_{IN} can be used to further reduce the voltage drop experienced as the switch is turned on into a large capacitive load.

Output Capacitor

A 0.1 μF capacitor, C_{OUT} , should be placed between V_{OUT} and GND. This capacitor prevents parasitic board inductance from forcing V_{OUT} below GND when the switch turns off. Due to the integral body diode in the

PMOS switch, a C_{IN} greater than C_{OUT} is recommended. A C_{OUT} greater than C_{IN} can cause V_{OUT} to exceed V_{IN} when the system supply is removed. This could result in current flow through the body diode from V_{OUT} to V_{IN} .

Board Layout

For best performance, all traces should be as short as possible. To be most effective, the input and output capacitors should be placed close to the device to minimize the effects that parasitic trace inductances may have on normal and short-circuit operation. Using wide traces for V_{IN} , V_{OUT} , and GND minimizes the parasitic electrical effects and case-to-ambient thermal impedance.

Physical Dimensions

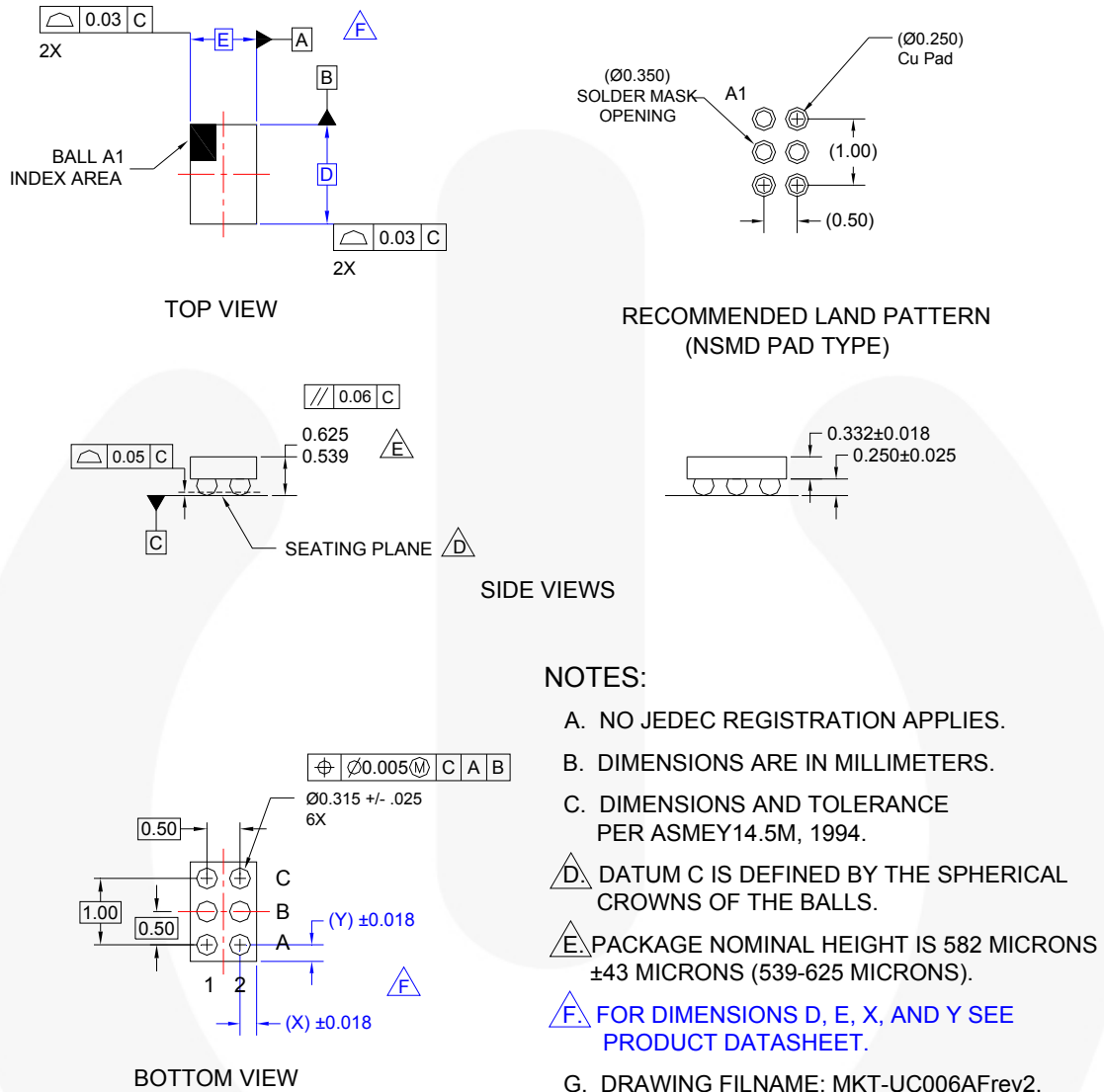

Figure 25. 1.0 x 1.5 mm² Wafer-Level Chip-Scale Package (WLCSP)

Product-Specific Dimensions

Product	D	E	X	Y
FPF1003A	1480 μm ± 30 μm	980 μm ± 30 μm	240 μm	240 μm
FPF1004	1480 μm ± 30 μm	980 μm ± 30 μm	240 μm	240 μm

Package drawings are provided as a service to customers considering Fairchild components. Drawings may change in any manner without notice. Please note the revision and/or date on the drawing and contact a Fairchild Semiconductor representative to verify or obtain the most recent revision. Package specifications do not expand the terms of Fairchild's worldwide terms and conditions, specifically the warranty therein, which covers Fairchild products.

Always visit Fairchild Semiconductor's online packaging area for the most recent package drawings:

<http://www.fairchildsemi.com/packaging/>



TRADEMARKS

The following includes registered and unregistered trademarks and service marks, owned by Fairchild Semiconductor and/or its global subsidiaries, and is not intended to be an exhaustive list of all such trademarks.

2Cool™	F-PFS™	PowerTrench®	The Power Franchise®
AccuPower™	FRFET®	PowerXS™	the power franchise
AX-CAP™*	Global Power Resource™	Programmable Active Droop™	TinyBoost™
BitSiC™	GreenBridge™	QFET®	TinyBuck™
Build it Now™	Green FPS™	QS™	TinyCalc™
CorePLUS™	Green FPS™ e-Series™	Quiet Series™	TinyLogic®
CorePOWER™	Gmax™	RapidConfigure™	TINYOPTO™
CROSSVOLT™	GTO™	 ™	TinyPower™
CTL™	IntelliMAX™	Saving our world, 1mW/W/kW at a time™	TinyPWM™
Current Transfer Logic™	ISOPLANAR™	SignalWise™	TinyWire™
DEUXPEED®	Making Small Speakers Sound Louder and Better™	SmartMax™	TranSiC™
Dual Cool™	MegaBuck™	SMART START™	TriFault Detect™
EcoSPARK®	MICROCOUPLER™	Solutions for Your Success™	TRUECURRENT®*
EfficientMax™	MicroFET™	SPM®	µSerDes™
ESBC™	MicroPak™	STEALTH™	 SerDes™
 Fairchild®	MicroPak2™	SuperFET®	UHC™
Fairchild Semiconductor®	MillerDrive™	SuperSOT™-3	Ultra FRFET™
FACT Quiet Series™	MotionMax™	SuperSOT™-6	UniFET™
FACT®	mWSaver™	SuperSOT™-8	VCX™
FAST®	OptoHi™	SupreMOS®	VisualMax™
FastvCore™	OPTOLOGIC®	SyncFET™	VoltagePlus™
FETBench™	OPTOPLANAR®	Sync-Lock™	XS™
FlashWriter®*		 SYSTEM GENERAL®*	
FPS™			

* Trademarks of System General Corporation, used under license by Fairchild Semiconductor.

DISCLAIMER

FAIRCHILD SEMICONDUCTOR RESERVES THE RIGHT TO MAKE CHANGES WITHOUT FURTHER NOTICE TO ANY PRODUCTS HEREIN TO IMPROVE RELIABILITY, FUNCTION, OR DESIGN. FAIRCHILD DOES NOT ASSUME ANY LIABILITY ARISING OUT OF THE APPLICATION OR USE OF ANY PRODUCT OR CIRCUIT DESCRIBED HEREIN; NEITHER DOES IT CONVEY ANY LICENSE UNDER ITS PATENT RIGHTS, NOR THE RIGHTS OF OTHERS. THESE SPECIFICATIONS DO NOT EXPAND THE TERMS OF FAIRCHILD'S WORLDWIDE TERMS AND CONDITIONS, SPECIFICALLY THE WARRANTY THEREIN, WHICH COVERS THESE PRODUCTS.

LIFE SUPPORT POLICY

FAIRCHILD'S PRODUCTS ARE NOT AUTHORIZED FOR USE AS CRITICAL COMPONENTS IN LIFE SUPPORT DEVICES OR SYSTEMS WITHOUT THE EXPRESS WRITTEN APPROVAL OF FAIRCHILD SEMICONDUCTOR CORPORATION.

As used herein:

1. Life support devices or systems are devices or systems which, (a) are intended for surgical implant into the body or (b) support or sustain life, and (c) whose failure to perform when properly used in accordance with instructions for use provided in the labeling, can be reasonably expected to result in a significant injury of the user.
2. A critical component in any component of a life support, device, or system whose failure to perform can be reasonably expected to cause the failure of the life support device or system, or to affect its safety or effectiveness.

ANTI-COUNTERFEITING POLICY

Fairchild Semiconductor Corporation's Anti-Counterfeiting Policy. Fairchild's Anti-Counterfeiting Policy is also stated on our external website, www.fairchildsemi.com, under Sales Support.

Counterfeiting of semiconductor parts is a growing problem in the industry. All manufacturers of semiconductor products are experiencing counterfeiting of their parts. Customers who inadvertently purchase counterfeit parts experience many problems such as loss of brand reputation, substandard performance, failed applications, and increased cost of production and manufacturing delays. Fairchild is taking strong measures to protect ourselves and our customers from the proliferation of counterfeit parts. Fairchild strongly encourages customers to purchase Fairchild parts either directly from Fairchild or from Authorized Fairchild Distributors who are listed by country on our web page cited above. Products customers buy either from Fairchild directly or from Authorized Fairchild Distributors are genuine parts, have full traceability, meet Fairchild's quality standards for handling and storage and provide access to Fairchild's full range of up-to-date technical and product information. Fairchild and our Authorized Distributors will stand behind all warranties and will appropriately address any warranty issues that may arise. Fairchild will not provide any warranty coverage or other assistance for parts bought from Unauthorized Sources. Fairchild is committed to combat this global problem and encourage our customers to do their part in stopping this practice by buying direct or from authorized distributors.

PRODUCT STATUS DEFINITIONS

Definition of Terms

Datasheet Identification	Product Status	Definition
Advance Information	Formative / In Design	Datasheet contains the design specifications for product development. Specifications may change in any manner without notice.
Preliminary	First Production	Datasheet contains preliminary data; supplementary data will be published at a later date. Fairchild Semiconductor reserves the right to make changes at any time without notice to improve design.
No Identification Needed	Full Production	Datasheet contains final specifications. Fairchild Semiconductor reserves the right to make changes at any time without notice to improve the design.
Obsolete	Not In Production	Datasheet contains specifications on a product that is discontinued by Fairchild Semiconductor. The datasheet is for reference information only.

Rev. 162