

SPECIFICATIONS	
OPERATING VOLTAGE	10-30 VDC
RIPPLE	≤ 10%
DIFFERENTIAL TRAVEL (HYSTERESIS)	3-15% (5% TYPICAL)
VOLTAGE DROP ACROSS CONDUCTING SENSOR	≤ 1.8 V at 200 mA
OUTPUT FUNCTION	NORMALLY OPEN 3-WIRE DC SELF-CONTAINED
TTL COMPATIBLE	NO
SHORT-CIRCUIT PROTECTED	YES
TRIGGER CURRENT FOR OVERLOAD PROTECTION	≥ 220 mA
CONTINUOUS LOAD CURRENT	≤ 200 mA
OFF-STATE (LEAKAGE) CURRENT	≤ 0.1 mA
NO-LOAD CURRENT	≤ 8 mA
TIME DELAY BEFORE AVAILABILITY	≤ 8 ms
POWER-ON EFFECT	PER IEC 947-5-2
REVERSE POLARITY PROTECTION	INCORPORATED
WIRE-BREAK PROTECTION	INCORPORATED
PROTECTION AGAINST TRANSIENTS	Per EN 60947-5-2
OPERATING TEMPERATURE (10% DRIFT)	-25°C to +70°C (-13°F to +158°F)
OPERATING TEMPERATURE (15% DRIFT)	-30°C to +85°C (-22°F to +185°F)
ENCLOSURE	MEETS NEMA 1, 3, 4, 6, 13 AND IEC IP67
SHOCK	30 g, 11 ms
VIBRATION	55 Hz, 1 mm AMPLITUDE (IN ALL 3 PLANES)
LED FUNCTION	YELLOW: OUTPUT ENERGIZED
RATED OPERATING DISTANCE(Sn)	15 mm = .591" (NOMINAL)
SWITCHING FREQUENCY	300 Hz
REPEATABILITY	≤ 2% of RATED OPERATING DISTANCE
EMBEDDABLE (SHIELDED)	YES
MATING PLUGS/CABLES	4-PIN "EUROFAST" CONSTRUCTION

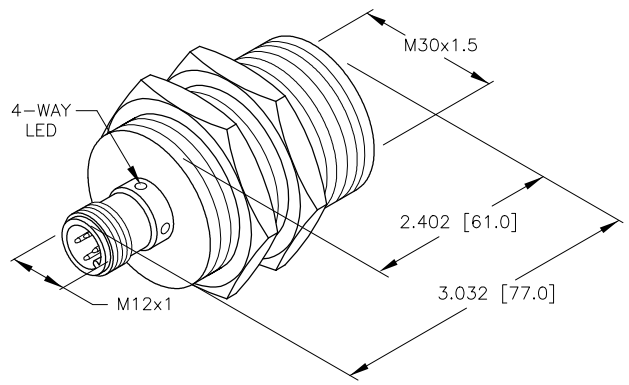

**NOTE
PRELIMINARY
SPECIFICATIONS**

SOURCE DRAWING - FOR REFERENCE ONLY

NOTE: ALL DIMENSIONAL TOLERANCES: ±1.0mm.

P3		CBM	06/16/00	
REV	DESCRIPTION	BY	DATE	ECO NO.

RELATED DOCUMENTS 1. 2. 3. 4.	3RD ANGLE PROJECTION 	THIS DOCUMENT IS PROPERTY OF TURCK INC. USE OF THIS DOCUMENT WITHOUT WRITTEN PERMISSION IS PROHIBITED.		TURCK INC <i>High Technology Sensors and Automation Controls</i> 3000 CAMPUS DRIVE MINNEAPOLIS, MN 55441 1-800-544-7769 (763) 553-7300 (763) 553-0708 fax turck.com	
	MATERIAL STAINLESS STEEL	TOLERANCES UNLESS OTHERWISE SPECIFIED 0.0394in [1.00mm]	DRFT IK	DATE 02/15/00	DESCRIPTION Bi15-M30E-AP6X-H1141
FINISH	UNIT OF MEASUREMENT INCH [MILLIMETER]		IDENTIFICATION NO. T4618590		REV P3
DO NOT SCALE THIS DRAWING			FILE: T4618590		SHEET 1 OF 1