



Emerg.stop label



Powering Business Worldwide™

Part no.
Article no.
Catalog No.

M22-XAK
216464
M22-XAKQ

Delivery programme

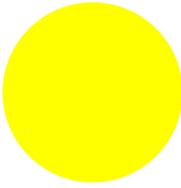
Product range			RMQ-Titan (drilling dimensions 22.5 mm)
Basic function			Accessories
Basic function accessories			Emergency-stop labels Emergency stop labels
Single unit/Complete unit			Single unit
Form			Diameter = 90 mm
Name			Blank
Colour			Yellow
			
RAL Value			RAL 1004
Protection type			IP66
Connection to SmartWire-DT			no
Notes			
Lettering black			

Approvals

NA Certification

UL/CSA certification not required

Technical data ETIM 4.0

Imprint			Without imprint
Imprint ISO symbols			Without imprint
Colour			Yellow
Shape			Round
Width		mm	90
Height		mm	90
Outer diameter		mm	90

Dimensions

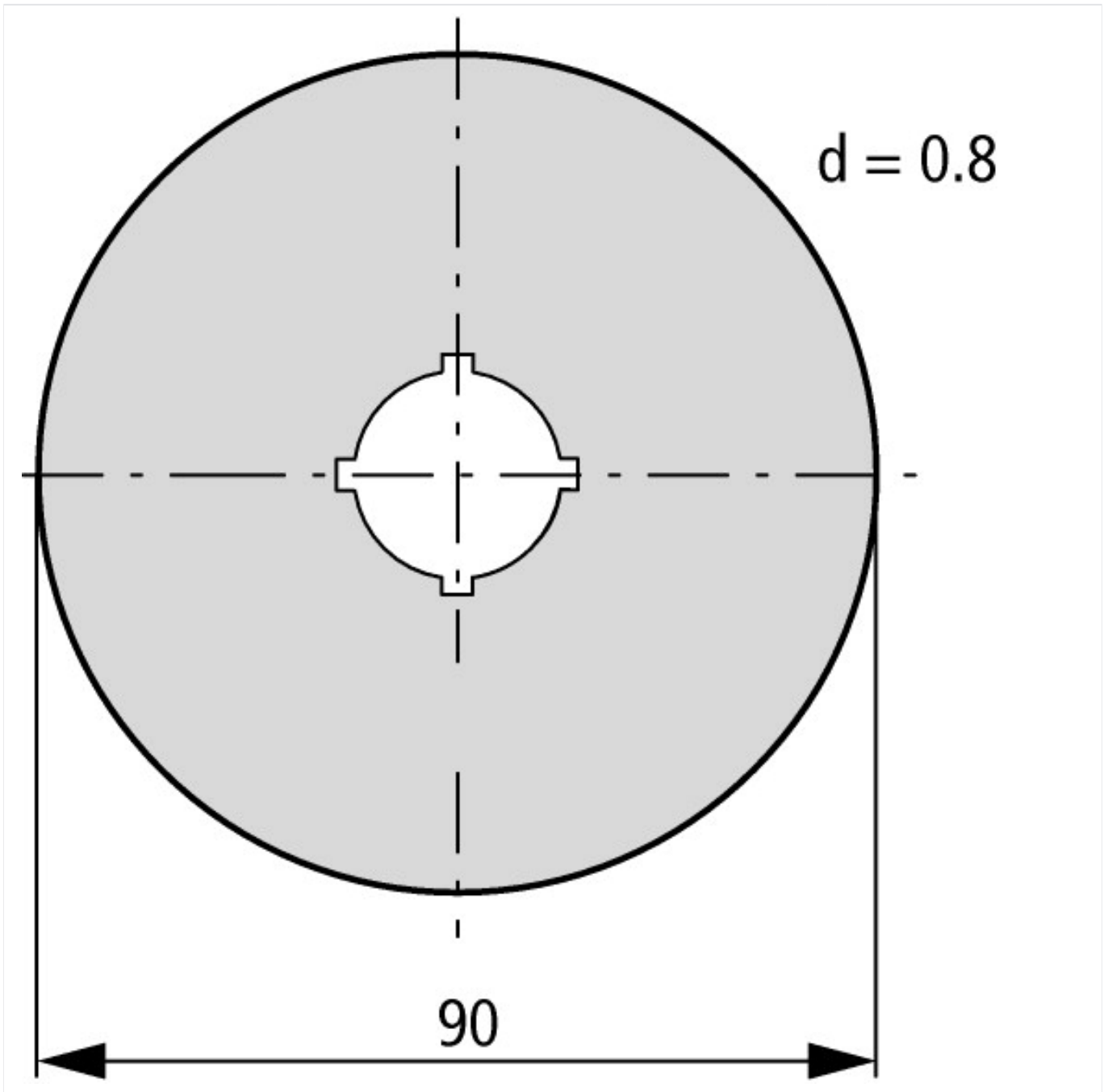

Additional product information (links)

IL04716002Z (AWA1160-1745) RMQ-Titan System

IL04716002Z (AWA1160-1745) RMQ-Titan System

ftp://ftp.moeller.net/DOCUMENTATION/AWA_INSTRUCTIONS/IL04716002Z2011_03.pdf