

## Features

- RoHS compliant\*
- Protects four lines
- ESD protection
- Low capacitance - 3.5 pF

## Applications

- Ethernet - 10/100/100 Base T
- Cellular phones
- Video/graphics cards
- USB 2.0 interface
- DVI interface

# CDSOT23-SRV05-4 — Steering Diode TVS Array Combo

## General Information

The markets of portable communications, computing and video equipment are challenging the semiconductor industry to develop increasingly smaller electronic components.

Bourns offers Transient Voltage Suppressor Array diodes for surge and ESD protection applications, in compact chip package SOT23-6 size. Bourns® Chip Diodes conform to JEDEC standards, are easy to handle on standard pick and place equipment and their flat configuration minimizes roll away.

The Bourns® device will meet IEC 61000-4-2 (ESD), IEC 61000-4-4 (EFT) and IEC 61000-4-5 (Surge) requirements.

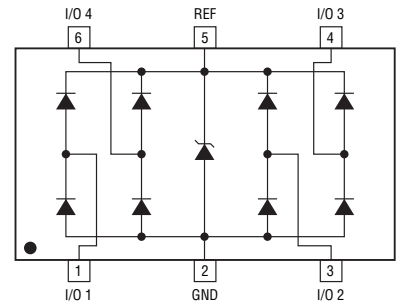

## Electrical Characteristics (@ T<sub>A</sub> = 25 °C Unless Otherwise Noted)

Parameter	Symbol	Min.	Nom.	Max.	Unit
Peak Pulse Current (t <sub>p</sub> = 8/20 μs)	I <sub>PP</sub>			30	A
Peak Pulse Power (t <sub>p</sub> = 8/20 μs) <sup>1</sup>	P <sub>PP</sub>			500	W
Working Peak Reverse Voltage	V <sub>WM</sub>			5	V
Breakdown Voltage @ 1 mA	V <sub>BR</sub>	6			V
Leakage Current @ V <sub>WM</sub>	I <sub>D</sub>			5	μA
Capacitance	C <sub>j(SD)</sub>		3.5	5	pF
Forward Surge Rating (1/20 s @ 25 °C, I <sub>F</sub> = 10 mA)	V <sub>F</sub>			1.5	V
Clamping Voltage (per IEC 61000-4-5) 8/20 μs)	@ I <sub>PP</sub> = 1 A			12	V
	@ I <sub>PP</sub> = 5 A			15	
ESD Protection (per IEC 61000-4-2) Contact Discharge Air Discharge	ESD	8			kV
		15			
EFT Protection (per IEC 61000-4-4) @ 5/50 ns	EFT	40			A

Notes:

1. See Peak Pulse Power vs. Pulse Time.

## Thermal Characteristics (@ T<sub>A</sub> = 25 °C Unless Otherwise Noted)

Parameter	Symbol	Min.	Nom.	Max.	Unit
Operating Temperature	T <sub>J</sub>	-55	+25	+150	°C
Storage Temperature	T <sub>STG</sub>	-55	+25	+150	°C

\*RoHS Directive 2002/95/EC Jan. 27, 2003 including annex and RoHS Recast 2011/65/EU June 8, 2011. Specifications are subject to change without notice. Customers should verify actual device performance in their specific applications.

# CDSOT23-SRV05-4 — Steering Diode TVS Array Combo

**BOURNS®**

## Mechanical Characteristics

This is a molded JEDEC SOT23-6 package with 100 % Matte Sn on the lead frame. It weighs approximately 15 mg and has a flammability rating of UL 94V-0.

## Product Dimensions

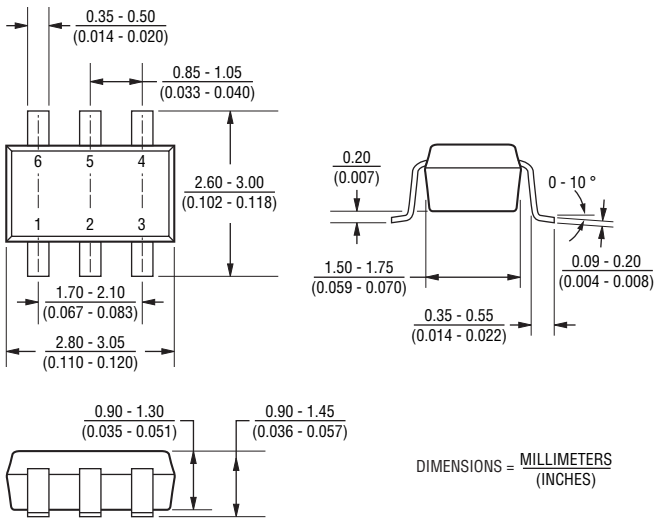

## Recommended Footprint

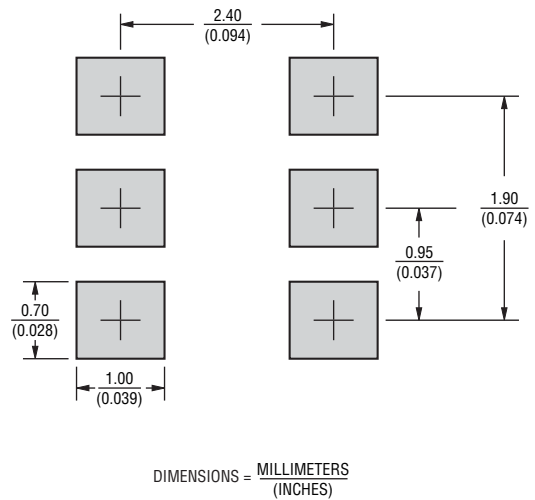

## Packaging Information

The product will be dispensed in tape and reel format (see diagram below).

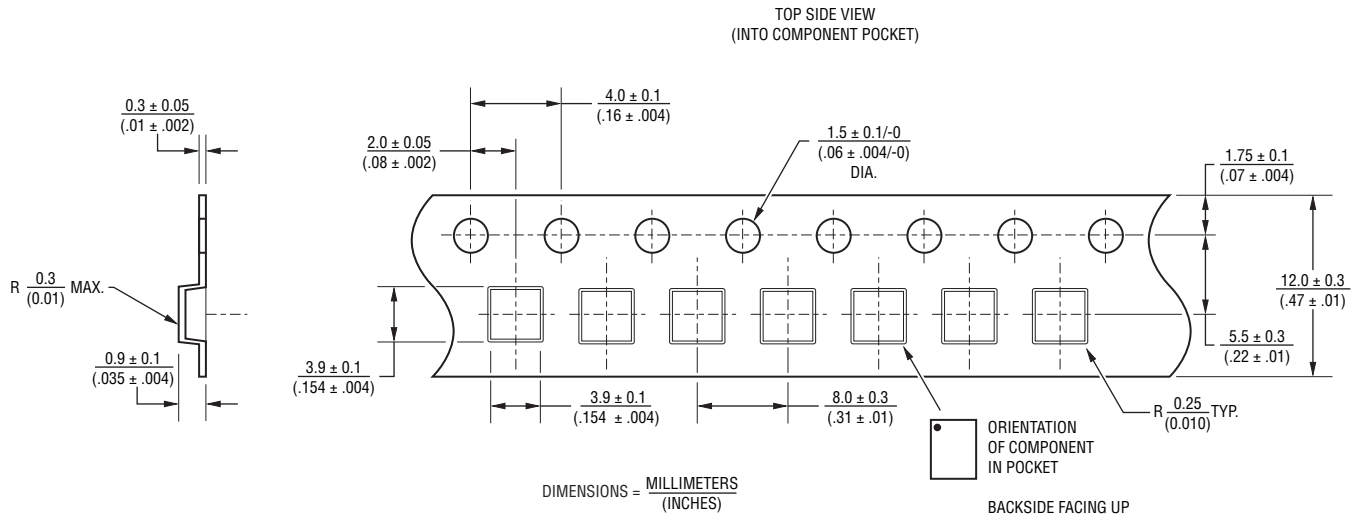

Devices are packed in accordance with EIA standard RS-481-A and specifications shown here.

Specifications are subject to change without notice. Customers should verify actual device performance in their specific applications.

# CDSOT23-SRV05-4 — Steering Diode TVS Array Combo



## Performance Graphs

### Peak Pulse Power vs. Pulse Time

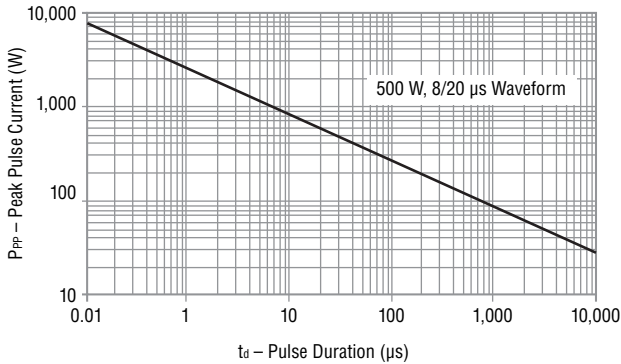

### Pulse Waveform

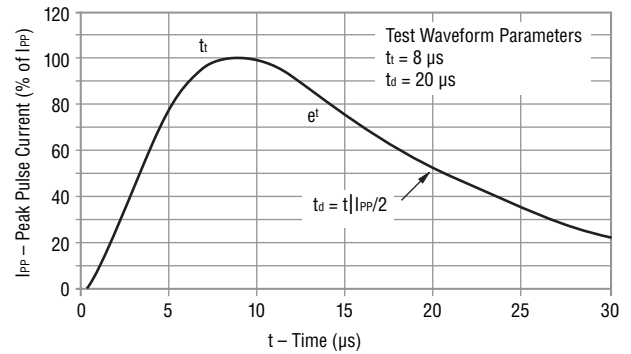

### Block Diagram

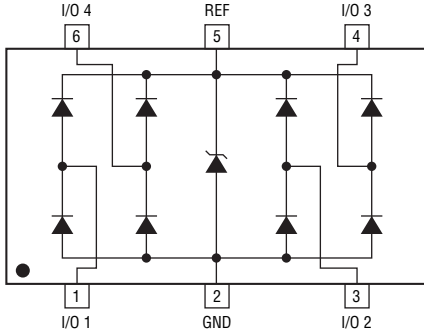

### Power Derating Curve

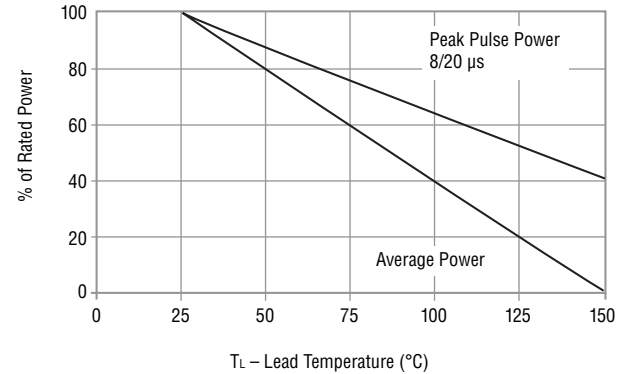

### How to Order

**CD SOT23 - SRV 05 - 4**

Common Code \_\_\_\_\_  
 CD = Chip Diode

Package \_\_\_\_\_  
 SOT23 = SOT23-6 Package

Model \_\_\_\_\_  
 SRV = Steering Diode Array

Working Peak Reverse Voltage \_\_\_\_\_  
 05 = 5  $V_{RWM}$  (Volts)

Number of Protection Lines \_\_\_\_\_

### Typical Part Marking

CDSOT23-SRV05-4 ..... S5

REV. 11/12

Specifications are subject to change without notice.  
 Customers should verify actual device performance in their specific applications.