

■ Features :

- Wide input range 180~480VAC
- Built-in active PFC function
- High efficiency up to 91%
- Protections: Short circuit / Overload / Over temperature
- Cooling by free air convection
- OCP point adjustable through output cable or internal potential meter
- IP67 / IP65 design for indoor or outdoor installations
- Three in one dimming function (0~10Vdc or 10V PWM signal or resistance)
- Suitable for LED lighting and street lighting applications
- Compliance to worldwide safety regulations for lighting
- Suitable for dry / damp / wet locations
- 5 years warranty



HVGC-100-350□A A : IP65 rated. Output voltage and constant current level can be adjusted through internal potential meter.
 B : IP67 rated. Constant current level adjustable through output cable with 0~10Vdc or 10V PWM signal or resistance.
 D : IP67 rated.

SPECIFICATION

MODEL	HVGC-100-350□	HVGC-100-700□		
OUTPUT	RATED CURRENT	350mA	700mA	
	OPERATING VOLTAGE RANGE	170 ~ 285V	85 ~ 142V	
	RATED POWER	99.75W	99.4W	
	RIPPLE & NOISE (max.) Note.2	3Vp-p	1.5Vp-p	
	CURRENT ADJ. RANGE	Can be adjusted by internal potential meter or through output cable		
		210 ~ 350mA	420 ~ 700mA	
	SETUP, RISE TIME	4000ms, 3000ms at full load 440VAC / 347VAC ; B type 5000ms, 500ms at 95% load 440VAC / 347VAC		
HOLD UP TIME (Typ.)	12ms at full load 440VAC / 347VAC			
INPUT	VOLTAGE RANGE Note.3	200 ~ 480VAC	282VDC ~ 679VDC	
	FREQUENCY RANGE	47 ~ 63Hz		
	POWER FACTOR	PF ≥ 0.95/440VAC	PF ≥ 0.98/347VAC at full load and rated output voltage	PF ≥ 0.9 at 60 ~ 100% load
	EFFICIENCY (Typ.)	92%	92%	
	AC CURRENT	0.32A / 347VAC	0.25A / 440VAC	
	INRUSH CURRENT(Typ.)	COLD START 75A / 440VAC		
	LEAKAGE CURRENT	<0.75mA / 440VAC		
PROTECTION	OVER CURRENT	95 ~ 108% Protection type : Constant current limiting, recovers automatically after fault condition is removed		
	SHORT CIRCUIT	Constant current limiting, recovers automatically after fault condition is removed		
	OVER VOLTAGE	305 ~ 315V	152 ~ 160V	
		Protection type : Shut down o/p voltage with auto-recovery or re-power on to recovery		
	OVER TEMPERATURE	100°C ±10°C (RTH2) Protection type : Shut down o/p voltage, recovers automatically after temperature goes down		
ENVIRONMENT	WORKING TEMP.	-40 ~ +60°C @ full load ; +70°C @ 60% load (Refer to derating curve)		
	WORKING HUMIDITY	20 ~ 95% RH non-condensing		
	STORAGE TEMP., HUMIDITY	-40 ~ +80°C, 10 ~ 95% RH		
	TEMP. COEFFICIENT	±0.03%/°C (0 ~ 50°C)		
	VIBRATION	10 ~ 500Hz, 5G 12min./1cycle, period for 72min. each along X, Y, Z axes		
SAFETY & EMC	SAFETY STANDARDS Note.4	UL8750, IP65 or IP67 approved ; Design refer to UL60950-1, TUV EN60950-1, EN61347-1, EN61347-2-13		
	WITHSTAND VOLTAGE	I/P-O/P:3.75KVAC	I/P-FG:1.88KVAC	O/P-FG:0.5KVAC
	ISOLATION RESISTANCE	I/P-O/P, I/P-FG, O/P-FG:100M Ohms / 500VDC / 25°C / 70% RH		
	EMI CONDUCTION & RADIATION	Compliance to EN55015,(CISPR22) Class B, FCC part 18 class A		
	HARMONIC CURRENT	Compliance to EN61000-3-2 Class C (≥ 50% load) ; EN61000-3-3		
	EMS IMMUNITY	Compliance to EN61000-4-2,3,4,5,6,8,11; ENV50204, EN61547, EN55024, heavy industry level (surge 4KV), criteria A		
OTHERS	MTBF	Khrs min. MIL-HDBK-217F (25°C)		
	DIMENSION	234*68*38.8 mm (L*W*H)		
	PACKING	Kg		
NOTE	<ol style="list-style-type: none"> 1. All parameters NOT specially mentioned are measured at 347VAC input, rated load and 25°C of ambient temperature. 2. Ripple & noise are measured at 20MHz of bandwidth by using a 12" twisted pair-wire terminated with a 0.1uf & 47uf parallel capacitor. 3. Derating may be needed under low input voltages. Please check the static characteristics for more details. 4. Safety and EMC design refer to EN60598-1, CNS15233, GB7000.1, FCC part18. 5. The power supply is considered as a component that will be operated in combination with final equipment. Since EMC performance will be affected by the complete installation, the final equipment manufacturers must re-qualify EMC Directive on the complete installation again. 			

Mechanical Specification

Case No. Unit:mm

A Type:(HVGC-100-_A)

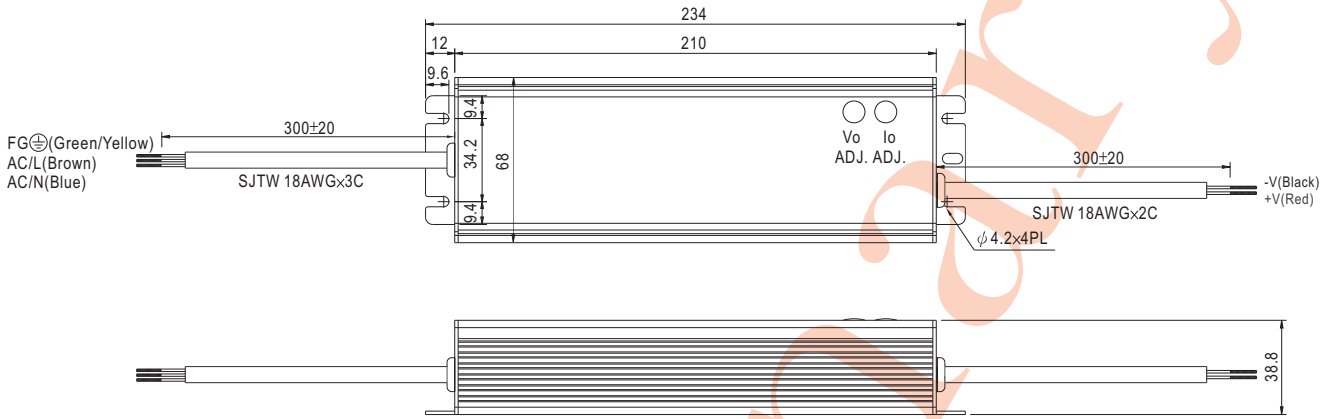

※ IP65 rated. Output voltage and constant current level can be adjusted through internal potential meter.
(Can access by removing the rubber stopper on the case.)

B Type:(HVGC-100-_B)

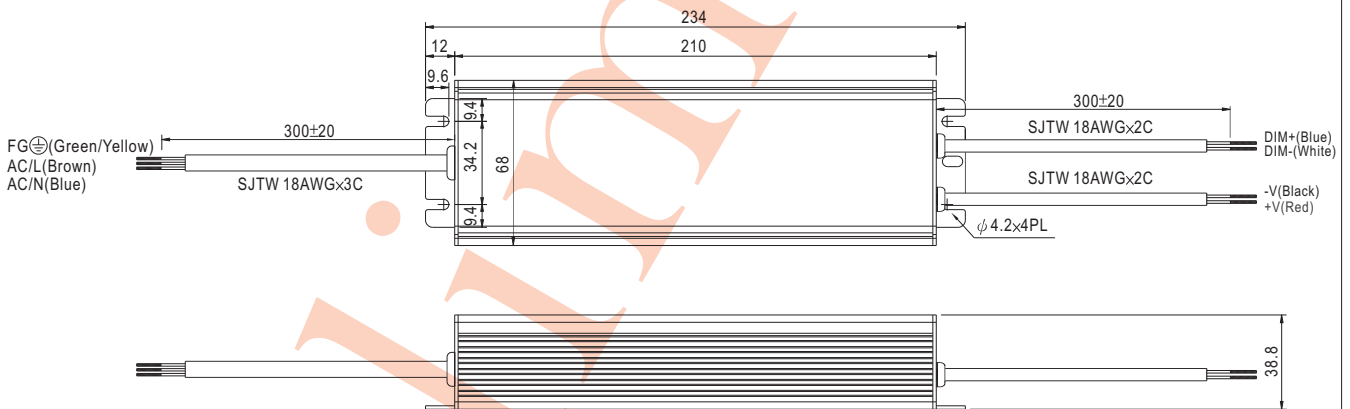

※ IP67 rated. Output constant current level can be adjusted through output cable by connecting a resistance or 0 ~ 10Vdc or 10V PWM signal between DIM+ and DIM-.

※ Please DO NOT connect "DIM-" to "-V".

※ Reference resistance value for output current adjustment (Typical)

Resistance value	10KΩ	20KΩ	30KΩ	40KΩ	50KΩ	60KΩ	70KΩ	80KΩ	90KΩ	100KΩ	OPEN
Percentage of rated current	10%	20%	30%	40%	50%	60%	70%	80%	90%	100%	102%~108%

※ 0 ~ 10V dimming function for output current adjustment (Typical)

Dimming value	0V	1V	2V	3V	4V	5V	6V	7V	8V	9V	10V	OPEN
Percentage of rated current	0%	10%	20%	30%	40%	50%	60%	70%	80%	90%	100%	102%~108%

※ 10V PWM signal for output current adjustment (Typical)

Duty value	10%	20%	30%	40%	50%	60%	70%	80%	90%	100%	OPEN
Percentage of rated current	10%	20%	30%	40%	50%	60%	70%	80%	90%	100%	102%~108%

D Type:(HVGC-100-_D)

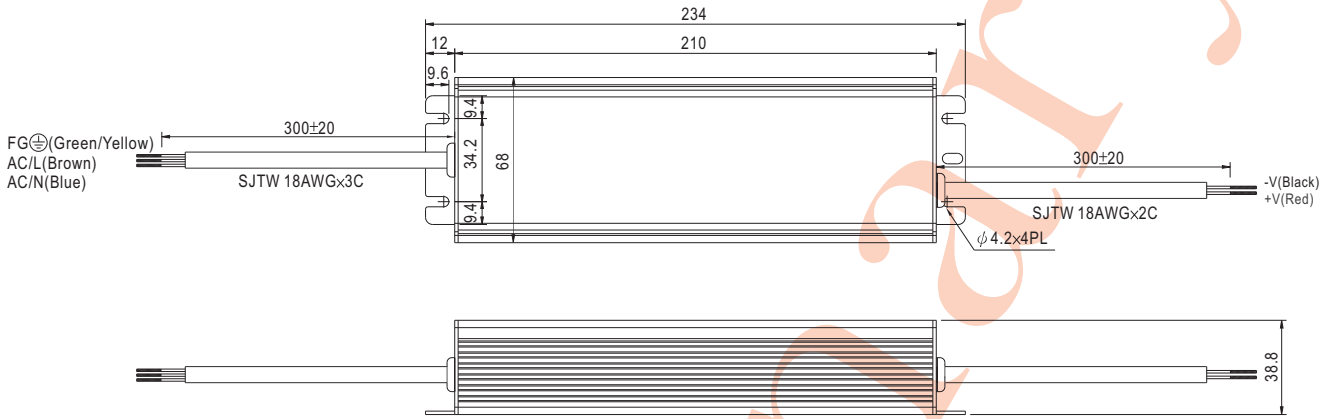

※IP67 rated. Cable for I/O connection.

■ Block Diagram

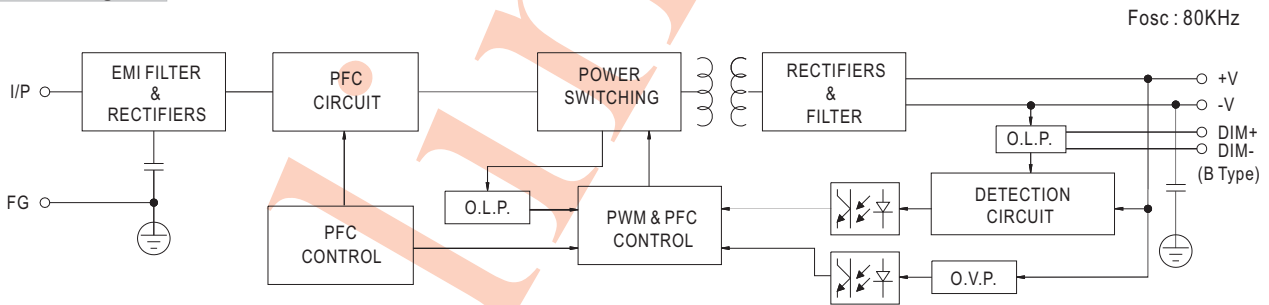

■ Derating Curve

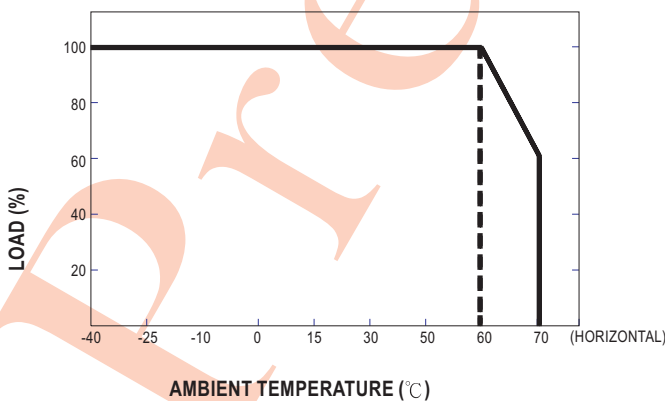

■ Static Characteristics

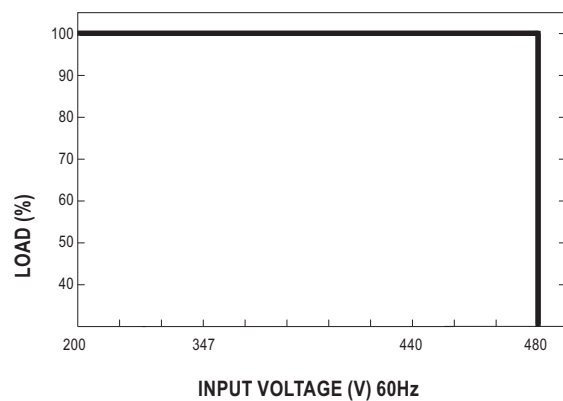

Power Factor Characteristic

Power factor will be higher than 0.9 when output loading is 50% or higher.

Constant Current Mode

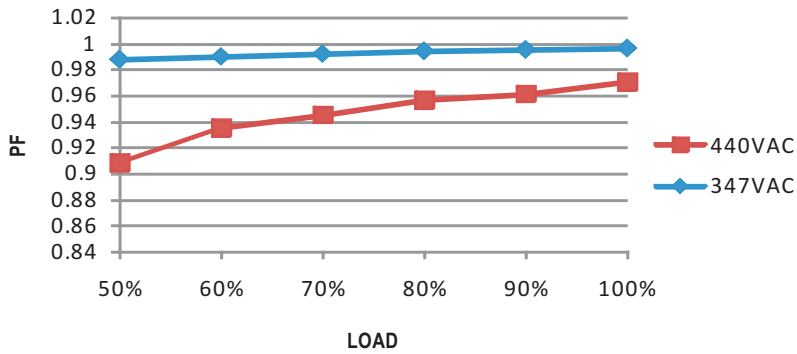

EFFICIENCY vs LOAD (48V Model)

HVGC-100 series possess superior working efficiency that up to 93% can be reached in field applications.

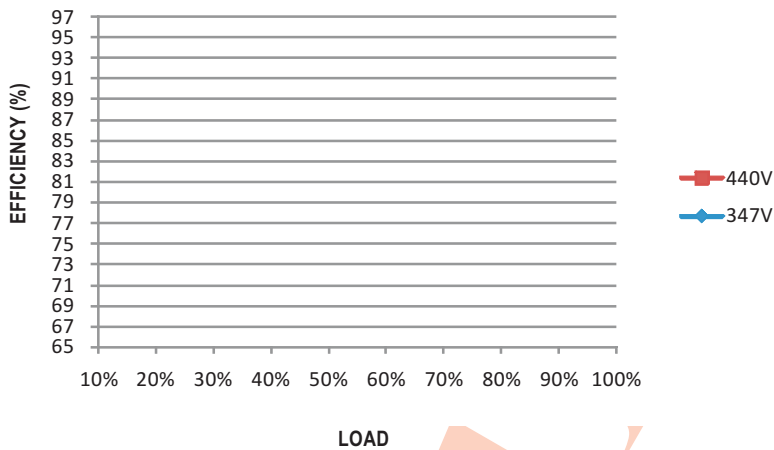

DRIVING METHODS OF LED MODULE

There are two major kinds of LED drive method "direct drive" and "with LED driver".

A typical LED power supply may either work in "constant voltage mode (CV) or constant current mode (CC)" to drive the LEDs.

Mean Well's LED power supply with CV+ CC characteristic can be operated at both CV mode (with LED driver, at area (A) and CC mode (direct drive, at area (B).

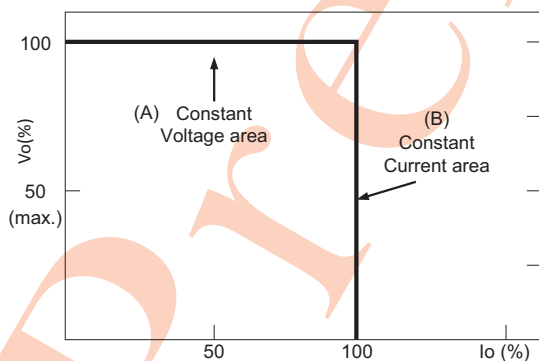

Typical LED power supply I-V curve

⊙ **Direct driving :**

Under direct driving, the power supply will work in "constant current mode (CC)" and output voltage of the power supply will be clamped by sum of forward voltage (Vf) of the LED strip.
The total forward voltage of series connecting LEDs is suggested for 60%~95% of power supply rated output voltage due to concern of the best PF value and efficiency.



⊙ **With LED driver :**

Using additional driver, the power supply will work in "constant voltage mode (CV)" and output voltage of the power supply will be kept in rated value. In this drive mode, several design issues need to be considered:

1. Output voltage of PSU must be higher than total forward voltage of series connecting LEDs by 3V minimum.
2. Input capacitor (Cin) of LED driver circuit should use 47uF ~ 100uF (typ.) of rating depends on the operating frequency of the LED driver. The higher the operating frequency is used, the smaller value of Cin should be chosen, and vice versa.
3. Do not use B type with LED driver.

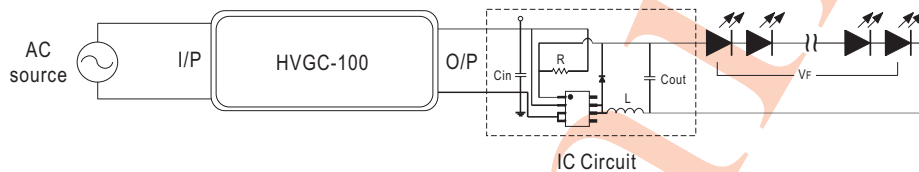

⊙ **Dimming application connection diagram (for turning the lighting ON/OFF) :**

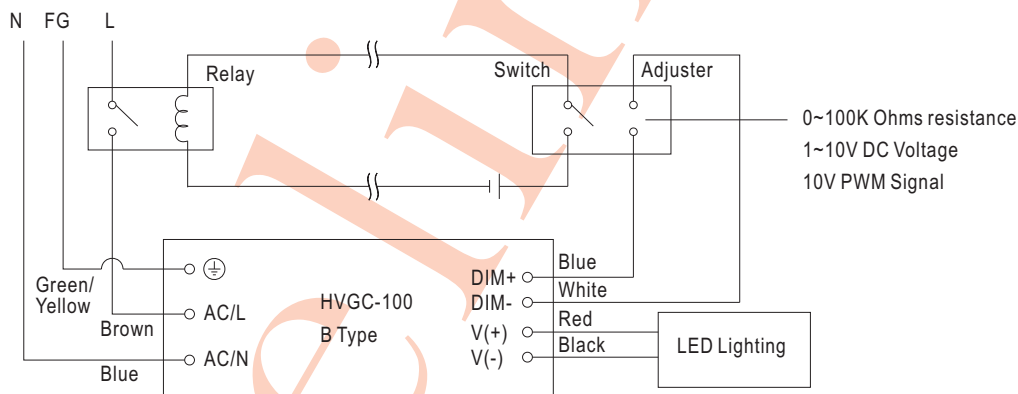

Using a switch and relay can turn ON/OFF the lighting.

1. Output constant current level can be adjusted through output cable by connecting a resistor or 1~10Vdc or 10V PWM signal between DIM+ and DIM-.
2. The LED lighting can be turned ON/OFF by the switch.

EMI DEBUG SUGGESTION

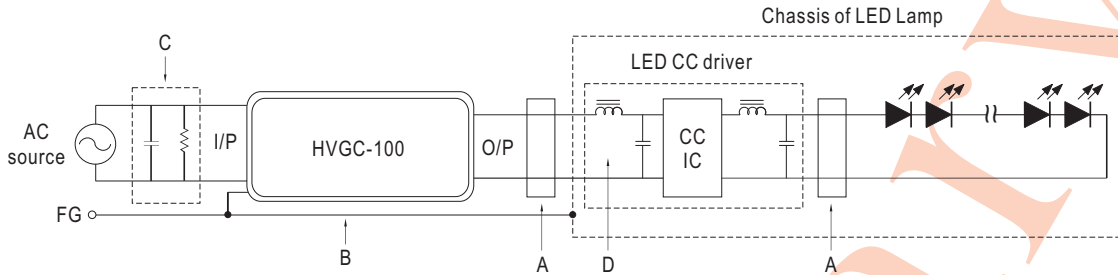

- A. Add a common mode ferrite choke on output wires to reduce the common emission between 10M ~ 300MHz per lighting EMI regulation.
- B. Chassis of LED lamp and chassis of HVGC-100 or the FG wire should be connected to the safety ground to reduce the EMI noise, including the conduction and radiation emission.
- C. The additional X-Cap and discharge resistor can reduce the low frequency conduction noise between 9K ~ 1MHz per lighting EMI regulation.
- D. L-C filter should be added at the DC input of LED constant current driver to avoid the differential emission and high frequency noise generated by the CC driver.

WATERPROOF CONNECTION

Waterproof connector

Waterproof connector can be assembled on the output cable of HVGC-100 to operate in dry/wet/damp or outdoor environment.

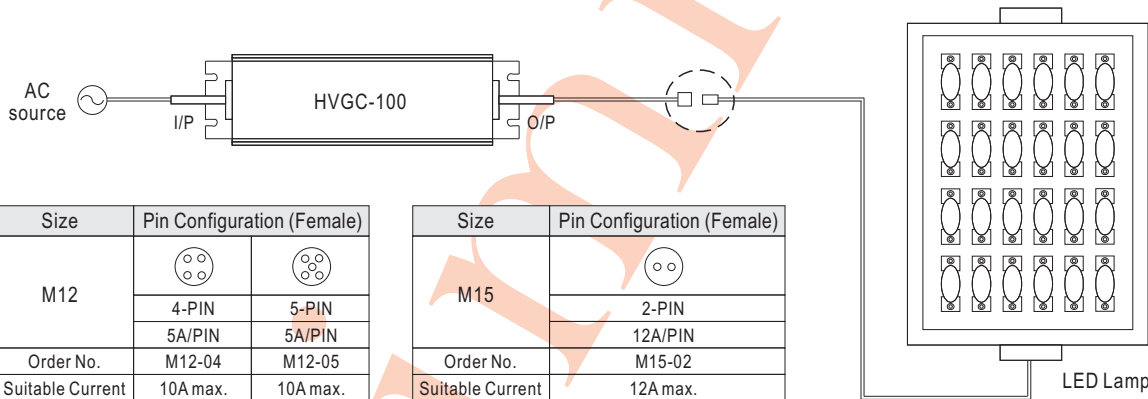

Cable Joiner

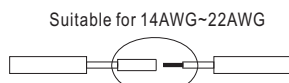
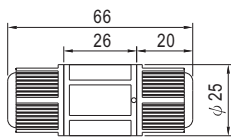

Up to four wires can be connected through this cable joiner by soldering or clamping by tools.

