

# SIEMENS

## SITOP power supply

### SITOP PSU400M

#### Manual

#### Overview

---

Safety instructions

1

Description, device design,  
dimension drawing

2

Mounting/removal

3

Mounting position, mounting  
clearances

4

Installation

5

Technical data

6

Safety, approvals, EMC

7

Ambient conditions

8

Applications

9

Environment

10

Service & Support

11

SITOP PSU400M 24 V/20 A  
6EP1536-3AA00

11.2014

C98130-A7601-A1-3-7629

## Legal information

### Warning notice system

This manual contains notices you have to observe in order to ensure your personal safety, as well as to prevent damage to property. The notices referring to your personal safety are highlighted in the manual by a safety alert symbol, notices referring only to property damage have no safety alert symbol. These notices shown below are graded according to the degree of danger.

<b>⚠ DANGER</b>
indicates that death or severe personal injury <b>will</b> result if proper precautions are not taken.
<b>⚠ WARNING</b>
indicates that death or severe personal injury <b>may</b> result if proper precautions are not taken.
<b>⚠ CAUTION</b>
indicates that minor personal injury can result if proper precautions are not taken.
<b>NOTICE</b>
indicates that property damage can result if proper precautions are not taken.

If more than one degree of danger is present, the warning notice representing the highest degree of danger will be used. A notice warning of injury to persons with a safety alert symbol may also include a warning relating to property damage.

### Qualified Personnel

The product/system described in this documentation may be operated only by **personnel qualified** for the specific task in accordance with the relevant documentation, in particular its warning notices and safety instructions. Qualified personnel are those who, based on their training and experience, are capable of identifying risks and avoiding potential hazards when working with these products/systems.

### Proper use of Siemens products

Note the following:

<b>⚠ WARNING</b>
Siemens products may only be used for the applications described in the catalog and in the relevant technical documentation. If products and components from other manufacturers are used, these must be recommended or approved by Siemens. Proper transport, storage, installation, assembly, commissioning, operation and maintenance are required to ensure that the products operate safely and without any problems. The permissible ambient conditions must be complied with. The information in the relevant documentation must be observed.

### Trademarks

All names identified by ® are registered trademarks of Siemens AG. The remaining trademarks in this publication may be trademarks whose use by third parties for their own purposes could violate the rights of the owner.

### Disclaimer of Liability

We have reviewed the contents of this publication to ensure consistency with the hardware and software described. Since variance cannot be precluded entirely, we cannot guarantee full consistency. However, the information in this publication is reviewed regularly and any necessary corrections are included in subsequent editions.

# Overview

## Description



Figure 1 View of unit

SITOP PSU400M is a power supply for DC link voltages of drive systems. If the power fails, the energy of the flywheel mass and in the DC link capacitors is used to maintain the 24 V supply for the electronics. As a consequence, axes can be stopped or retracted in a controlled fashion. This can prevent expensive workpieces from being destroyed.

The key benefits of the product include:

- 600 VDC rated input voltage
- Operating voltage range 200 (300) ... 900 V DC
- High degree of efficiency up to 95 %
- Output voltage can be adjusted in the range 24...28.8 V
- Ambient temperature -25 ...+70° C (derating from 60° C)
- Brief overload capability of 150% for 5 s/min (extra power)
- No lateral mounting clearances are required
- Selectable short-circuit behavior
- Soft characteristic for parallel switching can be selected
- integrated signaling contact for "24 V O.K."

- Display of the operating state using 3 LEDs
- Adjustable starting delay for operation on the DC link of SINAMICS converters

### Ordering data

The following device versions are available:

Regulated SITOP PSU400M power supply	
Type	Order number
DC voltage input Output 24 V DC / 20 A	6EP1536-3AA00

Accessories	
Type	Order number
Device identification labels 20 mm × 7 mm, pastel turquoise	3RT1900-1SB20

# Table of contents

	<b>Overview.....</b>	<b>3</b>
<b>1</b>	<b>Safety instructions.....</b>	<b>7</b>
<b>2</b>	<b>Description, device design, dimension drawing.....</b>	<b>9</b>
2.1	Device description.....	9
2.2	Connections and terminal designation.....	10
2.3	Potentiometer.....	11
2.4	Operating displays and signaling.....	12
2.5	Selector switch.....	13
2.6	Block diagram.....	15
2.7	Dimensions and weight.....	16
<b>3</b>	<b>Mounting/removal.....</b>	<b>17</b>
<b>4</b>	<b>Mounting position, mounting clearances.....</b>	<b>19</b>
4.1	Standard mounting position.....	19
4.2	Other mounting positions.....	20
<b>5</b>	<b>Installation.....</b>	<b>23</b>
5.1	Line-side connection.....	23
5.2	Output-side connection.....	25
<b>6</b>	<b>Technical data.....</b>	<b>27</b>
6.1	Input.....	27
6.2	Output.....	31
6.3	Efficiency.....	34
6.4	Closed-loop control.....	34
6.5	Protection and monitoring.....	35
6.6	MTBF.....	35
6.7	Mechanical system.....	35
6.8	Accessories.....	36
6.9	Dimension drawing.....	36
<b>7</b>	<b>Safety, approvals, EMC.....</b>	<b>37</b>
7.1	Safety.....	37
7.2	Test voltage.....	38
7.3	Approvals.....	39

7.4	EMC .....	39
<b>8</b>	<b>Ambient conditions.....</b>	<b>41</b>
<b>9</b>	<b>Applications .....</b>	<b>43</b>
9.1	Parallel connection to increase the power rating .....	43
9.2	Parallel connection for redundancy .....	45
9.3	Series connection for increased voltage .....	46
9.4	Overload protection in the 24 V output circuit.....	47
9.5	Protection against short-time voltage dips .....	48
9.6	Protection against longer failure of the power supply voltage .....	49
<b>10</b>	<b>Environment .....</b>	<b>51</b>
<b>11</b>	<b>Service &amp; Support.....</b>	<b>53</b>

 **WARNING**

**Correct handling of the devices**

When operating electrical devices, it is inevitable that certain components will carry dangerous voltages.

Therefore, failure to handle the units properly can result in death or serious physical injury as well as extensive property damage.

Only appropriately qualified personnel may work on or in the vicinity of this equipment.

Perfect, safe, and reliable operation of this equipment is dependent on proper transportation, storage, installation and mounting.

Before installation or maintenance work can begin, the system's main switch must be switched off and measures taken to prevent it being switched on again.

If this instruction is not observed, touching live parts can result in death or serious injury.



## Description, device design, dimension drawing

### 2.1 Device description

SITOP PSU400M is a primary-clocked power supply for connection to DC supply voltages (e.g. to the DC link voltage of drive systems). An electronically regulated DC voltage that can be set via a potentiometer is available at the output of the device. The output of the device is isolated, no-load proof and short-circuit proof. The LED display indicates the operating status. The operating state of the device can be processed via the signaling contact. The operating state of the device can be processed via the signaling contact.

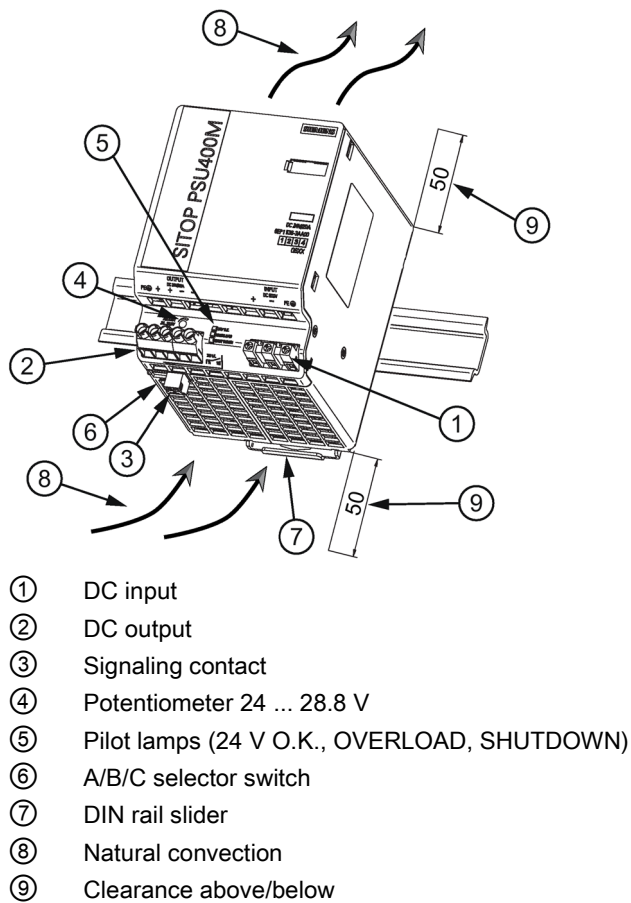





Figure 2-1 Design

## 2.2 Connections and terminal designation

The input terminals ① can be used to establish the connection to the supply voltage. Output terminals ② are used to connect to the loads to be supplied (see Section Installation (Page 23)).

The operating state of the device can be processed via the signaling contact ③ (function and contact rating, see Chapter Operating displays and signaling (Page 12)).

Connections and terminal designations	
① line input DC 600 V: "+", "-"	One screw terminal each
① Line input PE	1 screw terminal
② output "+"	2 screw terminals
② output "-"	2 screw terminals
② Output PE	1 screw terminal
③ signaling contacts 13, 14	One screw terminal each

	①	②	③	④
	SZS 0,6 x 3,5 / PZ1 / PH1	SZS 0,6 x 3,5 / PZ1 / PH1	SZS 0,4 x 2,5	SZS 0,4 x 2,5 / max. Ø 3,5 mm
	1 x 0,2 - 6 mm <sup>2</sup>	1 x 0,2 - 6 mm <sup>2</sup>	1 x 0,14 - 1,5 mm <sup>2</sup>	-
	1 x 0,2 - 4 mm <sup>2</sup>	1 x 0,2 - 4 mm <sup>2</sup>	1 x 0,14 - 1,5 mm <sup>2</sup>	-
AWG	24 - 10	24 - 10	28 - 16	-
Nm	0,5 - 0,6 Nm	0,5 - 0,6 Nm	0,22 Nm	0,04 Nm <sup>*1)</sup>
	8 mm	8 mm	7 mm	-

\*1) Do not subject the end stop to higher loads

Figure 2-2 Terminal data

## 2.3 Potentiometer

The potentiometer ④ on the front of the device is used to adjust the output voltage. The output voltage is set to 24 V in the factory, and can be adjusted in the range 24 ... 28.8 V; for example, to compensate voltage drops across long supply lines to the connected load.

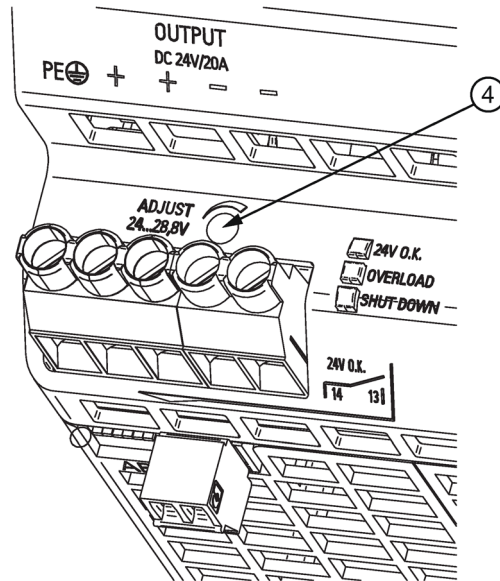

Figure 2-3 Potentiometer

### NOTICE

#### Thermal overload possible

When adjusting the output voltage to >24 V, the output current must be derated by 4 %/V, or the permissible ambient temperature must be taken into account with 3° C/V.

### Note

It is only permissible to use an insulated screwdriver when actuating the potentiometer.

For notes on actuating the potentiometer (screwdriver, torque), see Chapter Connections and terminal designation (Page 10).

## 2.4 Operating displays and signaling

<b>6EP1536-3AA00 (24 V/20 A)</b>	
Operating display	LED green, lit for "24 V O. K." LED flashing green: During the wait time for a delayed start with selector switch C in the "ON" position Yellow LED lit for overload condition ( $U_a < 20 \text{ V} \pm 0.5 \text{ V}$ ) Red LED lit for latching shutdown as a result of overload (only for selector switch B in the "ON" position) LED red flashing for prewarning and latching shutdown as a result of overtemperature
Signaling contact	Relay contact (NO contact, contact rating 30 V AC/0.5 A, DC 30 V/1 A) for "24 V O. K."

<b>Signaling</b>	<b>6EP1536-3AA00 (24 V/20 A)</b>
LED green (5.1) off Signaling contact (3), contacts 13-14 open (quiescent position)	No supply voltage
Green LED (5.1) lit Signaling contact (3), contacts 13-14 closed	Normal operation, output voltage $> 20 \text{ V} \pm 0.5 \text{ V}$
Green LED (5.1) flashing Signaling contact (3), contacts 13-14 open (quiescent position)	Output voltage = 0 V during delayed start
Yellow LED (5.2) lit Signaling contact (3), contacts 13-14 open (quiescent position)	Overload ( $U_a < 20 \text{ V} \pm 0.5 \text{ V}$ )
Green LED (5.1) lit and red LED (5.3) flashing Signaling contact (3), contacts 13-14 open (quiescent position)	Prewarning due to overtemperature, device switches off after approx. 10 s and latches in this condition. (reset possible after approx. 3 min with power OFF/ON)
Red LED (5.3) lit Signaling contact (3), contacts 13-14 open (quiescent position)	Latching shutdown due to overload
Red LED (5.3) flashing Signaling contact (3), contacts 13-14 open (quiescent position)	Shutdown due to overtemperature → reset using power OFF/ON after approx. 3 min

## 2.5 Selector switch

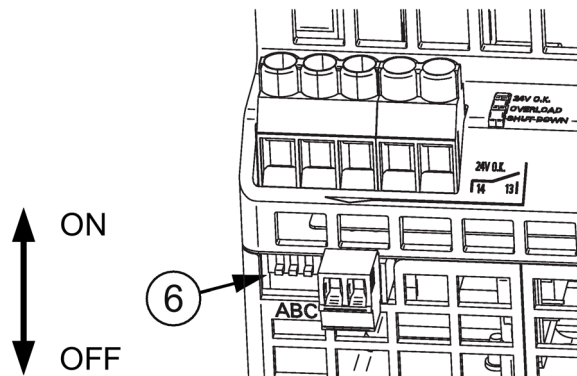

Figure 2-4 Selector switch

The different operating modes can be selected using selector switch ⑥. You can choose one of the following modes:

- (A) Parallel or single mode
- (B) Selectable overload response, constant current characteristic or latching shutdown
- (C) Delayed start

2.5 Selector switch

Switch	ON	OFF
<b>A</b> influences the output characteristic in the load range	<b>Parallel operation:</b> "Soft" characteristic curve (see Figure 6-7 Output characteristic parallel operation (Page 33)) for the parallel operation of two or more devices: The output voltage falls with increasing output current (namely, also for the overcurrent pulse!). This means that for full output current the highest output voltage can normally no longer be attained.	<b>Single operation:</b> <i>Delivery state</i> "Hard" characteristic curve (see Figure 6-6 Output characteristic single operation (Page 32)) for normal operation (single operation): The output voltage is independent of the output current.
<b>B</b> influences the output characteristic in the overload range	<b>Latching shutdown:</b> If the output current rises above the rated value and above the current limit, the device reduces the output voltage (see Figure 6-8 Output characteristic latching shutdown (Page 33)). If the output voltage falls below 20 V, the device shuts down latching, the red LED lights up. This limit voltage of 20 V is independent of the set output voltage. The 'Short-time overload current' feature is not available in this operating mode. In order to also be able to charge large capacitances in this operating mode at the output, non-latching shutdown is performed during the first ten seconds after power on. During these first 10 s, the device responds for overload as if the switch is "OFF".	<b>Constant current:</b> <i>Delivery state</i> If the output current rises above the rated value and above the current limit, the device reduces the output voltage. The yellow LED lights up if the output voltage falls below 20 V.
<b>C</b>	Start delay 10 s	Immediate start <i>Delivery state</i>

**Note**

Selector switches may only be activated when the device is switched off.

## 2.6 Block diagram

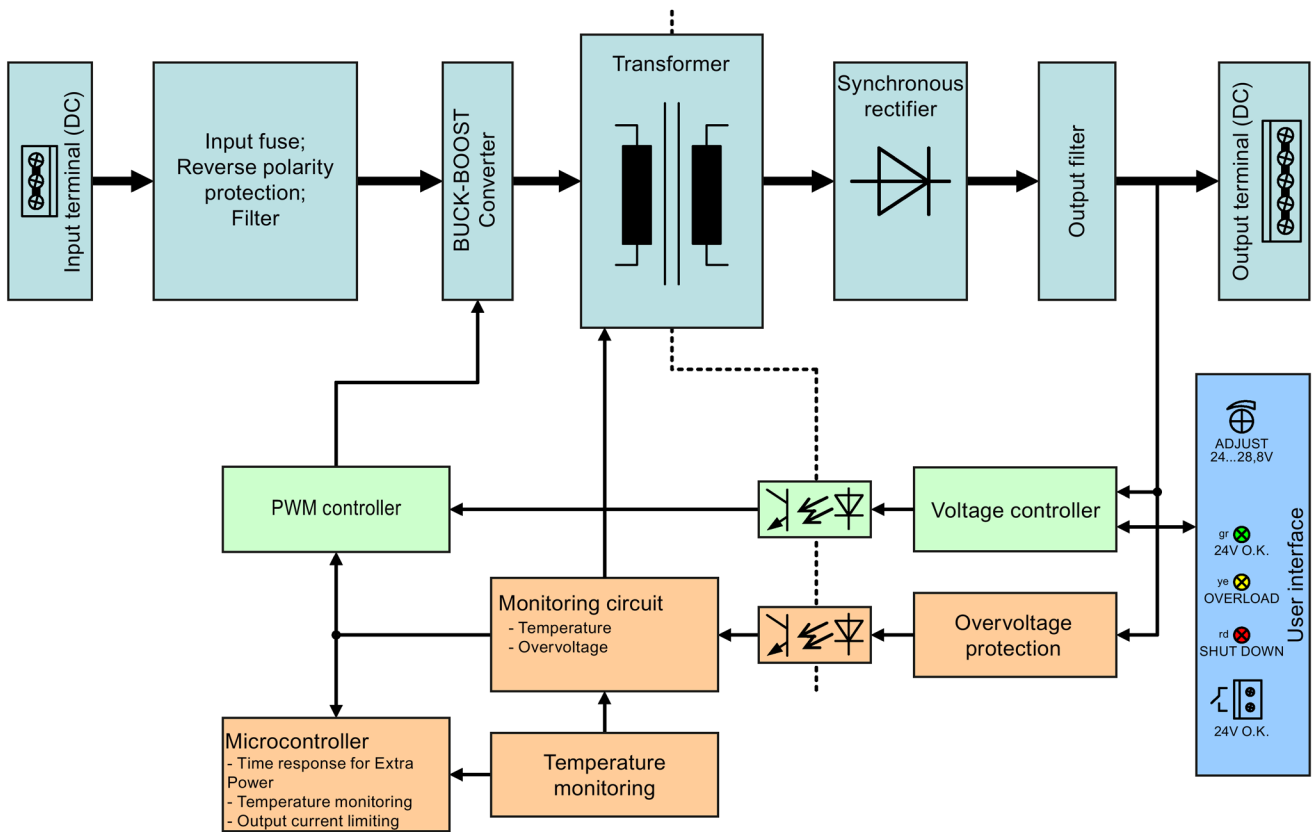

Figure 2-5 Block diagram

2.7 Dimensions and weight

2.7 Dimensions and weight

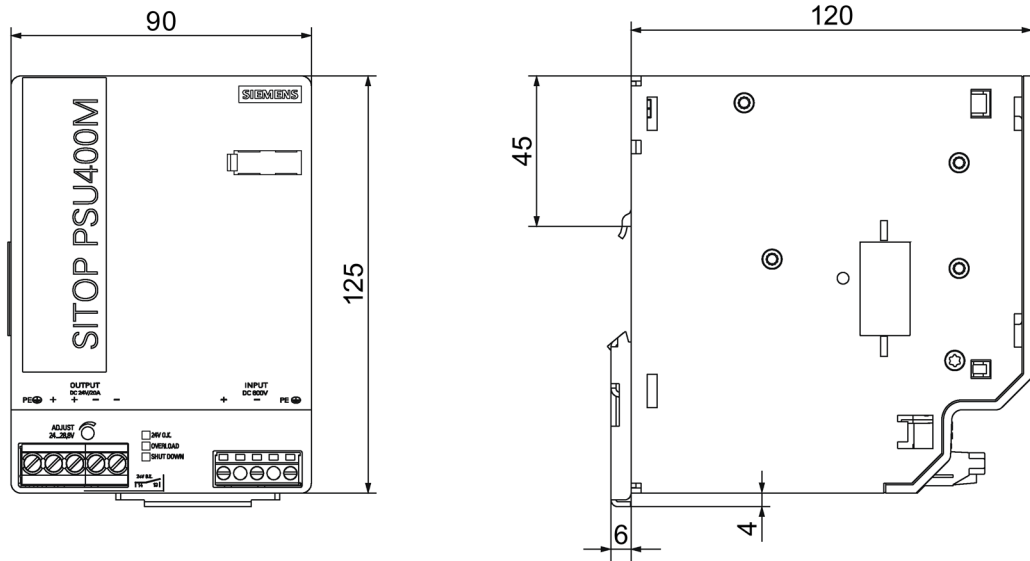

Figure 2-6 Dimension drawing

<b>6EP1536-3AA00 (24 V/20 A)</b>	
Dimensions (W × H × D) in mm	90 × 125 × 120
Weight	approx. 1.2 kg

## Mounting/removal

### WARNING

#### Installing the device in a housing or a control cabinet

The SITOP PSU400M power supply is a built-in device. It must be installed in a housing or control cabinet, to which only qualified personnel have access.

The device can be mounted in a control cabinet on standard mounting rails according to EN 60715 35x7,5/15.

#### Mounting

To mount the device, position it with the mounting rail guide at the upper edge of the standard mounting rail and press down to lock it into place. If this is too difficult, press slider ① at the same time, as described under "Removal".

#### Removal

To remove, pull up the slider ① using a screwdriver ② and disengage the device at the bottom edge of the standard mounting rail. Then you can remove the device from the upper edge of the standard mounting rail.

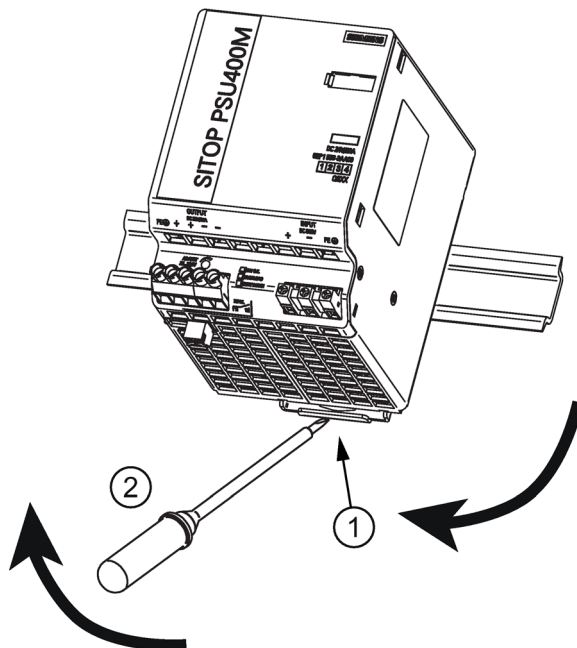

Figure 3-1 Mounting/removal



## Mounting position, mounting clearances

### 4.1 Standard mounting position

The device is mounted on standard mounting rails according to EN 60715. The device must be mounted vertically in such a way that the input terminals and the output terminals are at the bottom to ensure correct cooling.

A clearance of at least 50 mm should be maintained above and below the device (maximum depth of the cable duct, 50 mm).

No space is required at the side.

### Output current as a function of the ambient temperature and mounting height

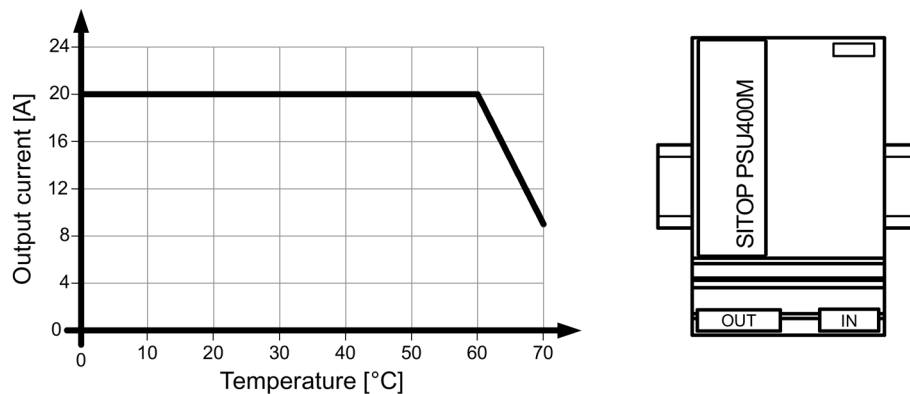

Figure 4-1 Output current in the standard mounting position

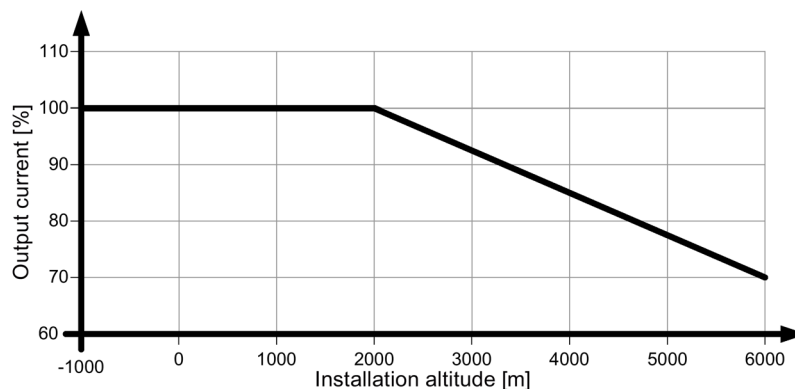

Figure 4-2 Mounting height derating

## 4.2 Other mounting positions

For mounting positions that deviate from the standard mounting position, derating factors (reduction of the output power or the permissible ambient temperature) must be observed in accordance with the following diagrams.

---

### Note

In the case of mounting positions that deviate from the standard mounting position, reduced mechanical resistance of the devices against vibration and shock must be expected.

Particularly when installing on a vertically fastened standard mounting rail, additional measures may be required, e.g. to prevent the device from slipping on the standard mounting rail.

---

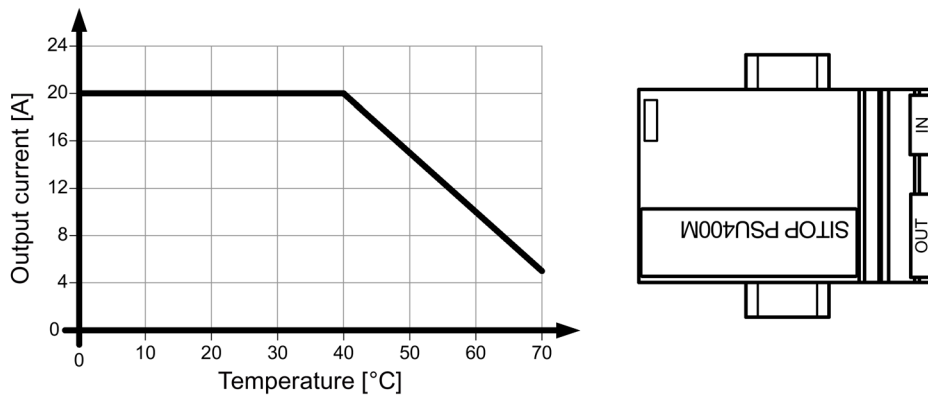

Figure 4-3 Mounting position (1)

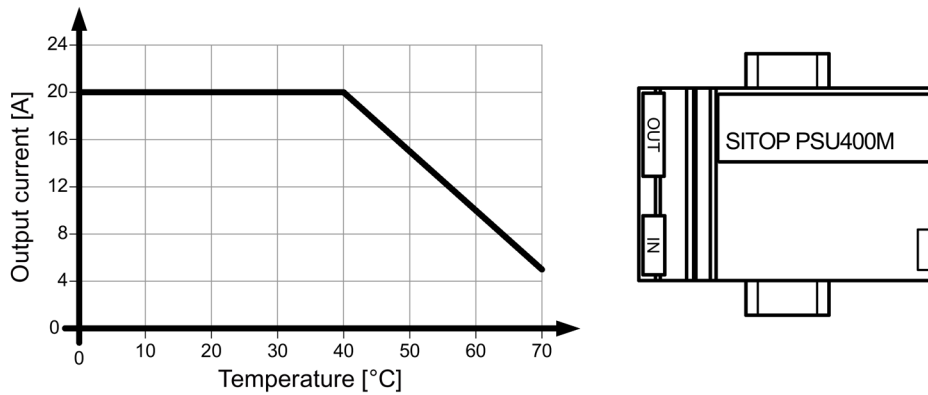

Figure 4-4 Mounting position (2)

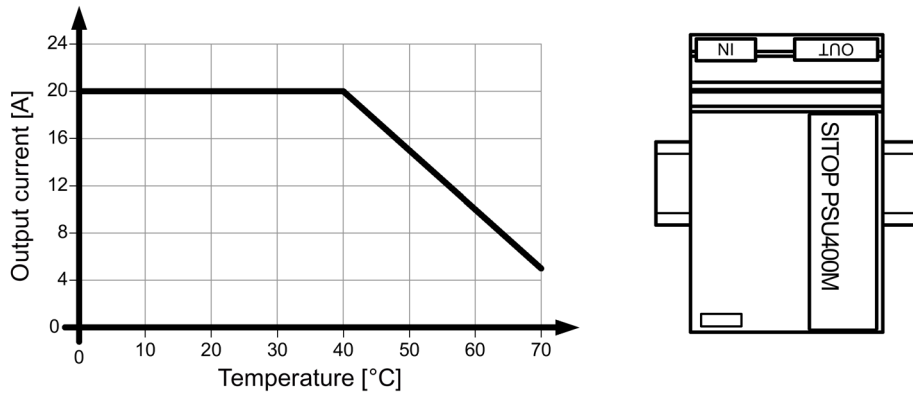

Figure 4-5 Mounting position (3)

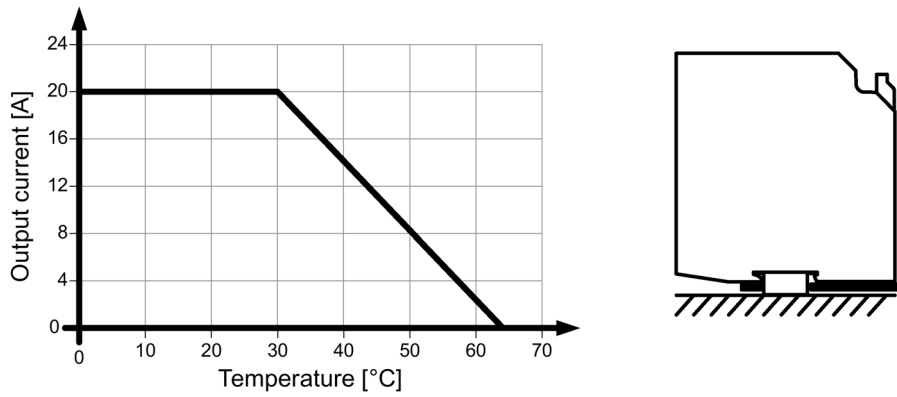

Figure 4-6 Mounting position (4)

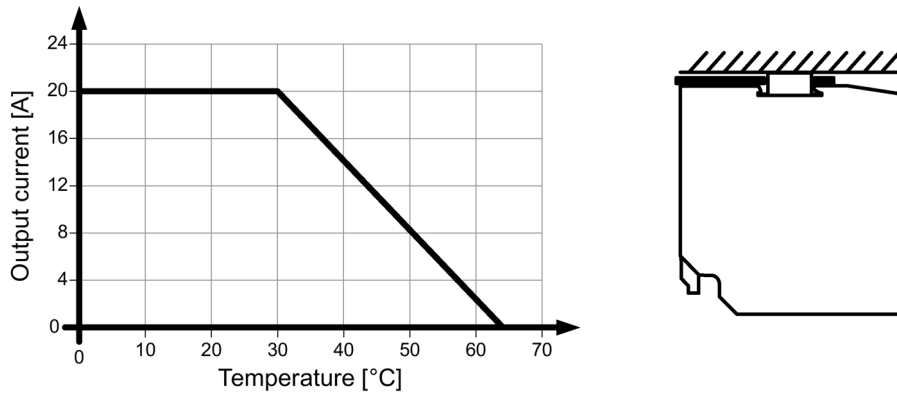

Figure 4-7 Mounting position (5)

*4.2 Other mounting positions*

<p><b>⚠ WARNING</b></p> <p><b>Hazard due to electric shock</b></p> <p>Before installation or maintenance work can begin, the system's main switch must be switched off and measures taken to prevent it being switched on again. If this instruction is not observed, touching live parts can result in death or serious injury.</p>
--

## 5.1 Line-side connection

The SITOP PSU400M power supply is designed for connection to a 600 V DC DC link with an operating voltage range from 200 (300) ... 900 V DC.

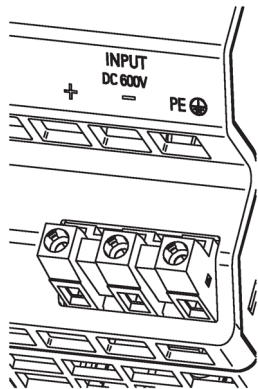

Figure 5-1 Line-side connection

The line supply is connected via terminals 600 V DC "+" and "-" and PE (see Figure 5-1 Line-side connection (Page 23)) and must be implemented according to IEC 60364, EN 50178 and EN 61800-5-1. A protective device (miniature circuit breaker or circuit breaker) and a disconnection unit for the power supply must be provided.

The device is to be connected to the inverter in parallel after the DC disconnecter.

In other applications, a surge arrester and/or an EMC filter may have to be provided.

<p><b>NOTICE</b></p> <p>Hot plug in and hot plug out are not permissible! Maximum voltage rate of rise of the supply voltage: 1 V/<math>\mu</math>s</p>
---

---

**Note**

A short-circuit proof supply line must be provided at the input side.

---

The breaking capacity of the internal fuse at input "+" and "-" is 20 kA; L/R < 2 ms.

The protective conductor of the line supply must be connected at the PE terminal. The cross-section of the protective conductor cable must be the same as the supply cable.

Other country-specific regulations may have to be observed when installing the device.

When installed in wind power plants, the device should only be operated in LPZ2, in accordance with IEC 61400-24.

## 5.2 Output-side connection

At its output, the SITOP PSU400M power supply provides an isolated PELV output voltage (Protected Extra Low Voltage). When connected to the converter DC link, the output must be grounded at one end. The ground connection should be established outside the device.

### Note

The SITOP PSU400M power supply has two protective conductor connections (PE). It is not permissible that the protective conductor is connected to the input, not even capacitively. The cross-section of the protective conductor connections (PE) must be the same as the supply cable.

The output is no-load, overload, and short-circuit proof. If an overload occurs, the electronic current limiting function limits the output current to a maximum value (see Section Technical data (Page 27)).

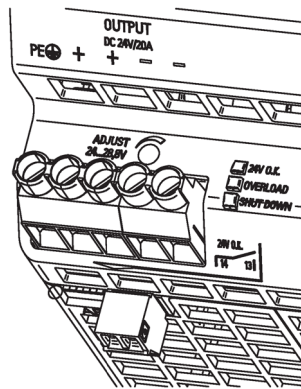

Figure 5-2 Output-side connection

The output voltage is connected via the + and - terminals at the output of the power supply (see Figure 5-2 Output-side connection (Page 25)). Ensure that the output cables are dimensioned correctly for the maximum output current rms value and fused accordingly.



## Technical data

---

### Note

Technical data is applicable for a rated input voltage, rated load and +25° C ambient temperature (if nothing else is specified).

---

## 6.1 Input

<b>6EP1536-3AA00 (24 V/20 A)</b>	
Input	DC voltage
Rated voltage U <sub>e</sub> rated for AC	-
Rated voltage U <sub>e</sub> rated for DC	600 V
Voltage range for AC	-
• Remark	
Voltage range for DC	200 ... 900 V (from product version 2: 300 ... 900 V)
• Remark	Product version 1: Starting from approx. 400 V; derating at 200 ... 300 V and 820 ... 900 V necessary, see Figure 6-1 Derating input range for product version 1 (Page 28) From product version 2: Starting from 340 V, derating at 300 ... 400 V and 824 ... 900 V required, (see Figure 6-2 Derating input range from product version 2 (Page 29), Figure 6-3 Input voltage ripple (Page 29) Figure 6-4 Voltage rate of rise (Page 30)
Wide-range input	Yes
Overvoltage strength	Shutdown at U <sub>e</sub> > 900 V
Power failure buffering at I <sub>a</sub> rated, min	-
Power failure buffering	-
Rated line frequency	-
Line frequency range	-
Input current / at rated value of input voltage 120 V	-
Input current / at rated value of input voltage 230 V	-
Input current / for DC/ at rated value of input voltage 600 V/rated value	0.85 A
Inrush current limiting (+25° C), max.	8 A
I <sup>2</sup> t, max	0.02 A <sup>2</sup> -s

6.1 Input

<b>6EP1536-3AA00 (24 V/20 A)</b>	
Integrated input fuse	Yes, breaking capacity 20 kA; L/R < 2 ms ("+" and "-" input)
Protection in the line feeder cable (IEC 898)	-

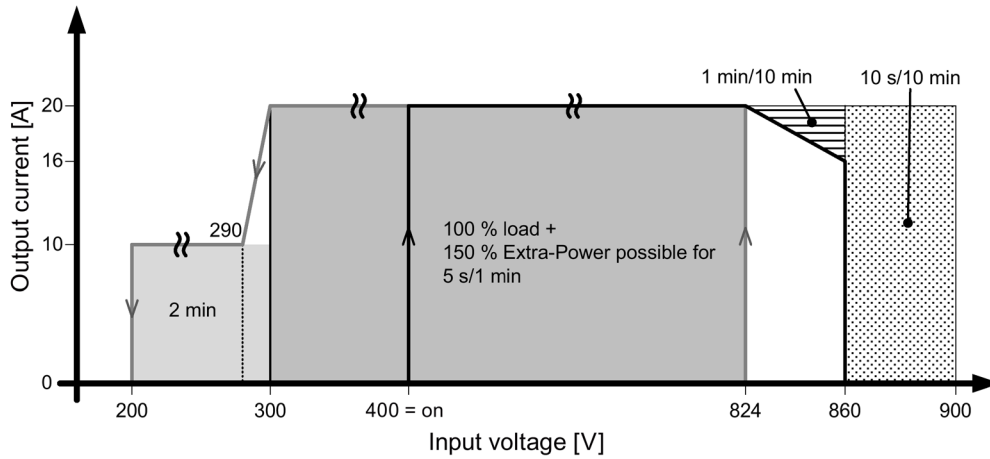

Ue = 300 ... 824 V DC: Rated power (480 W) and Extra Power (150 % for 5 s/min)

Ue = 200 ... 300 V DC: Operating range with current derating max. 10 A (2 min. max.)

Ue = 824 ... 860 V DC <1 min permissible (1x in 1 min.)

Ue = 860 ... 900 V DC <10 s permissible (1x in 10 min.)

In the operating range from 824 ... 900 V DC, the complete output power (20 A) is available within the specified times.

Between 824 and 860 V, the output voltage is continuously available, if a linear derating of 1 A per 10 V is taken into consideration.

Ue > 900 V DC: The output voltage is shut down

Ue > 975 V DC can result in device damage

Figure 6-1 Derating input range for product version 1

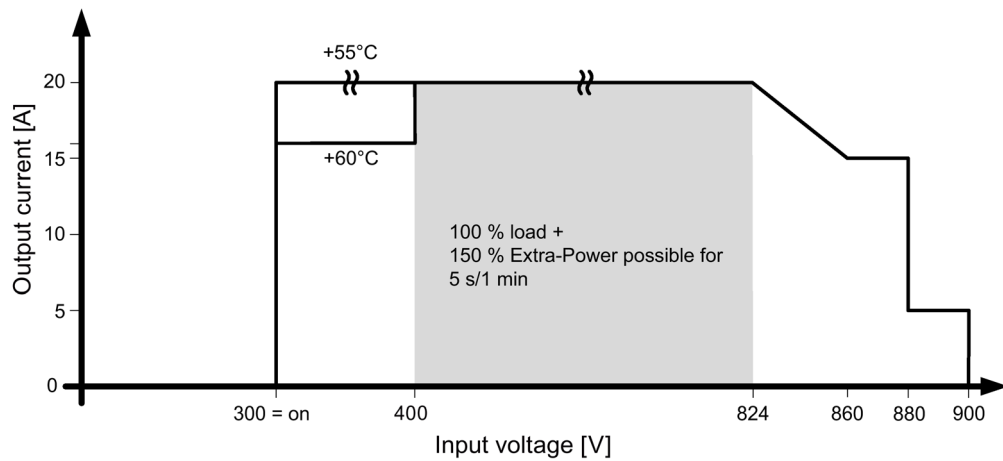

- U<sub>e</sub> = 400 ... 824 V DC: Rated power (480 W) and Extra Power (150 % for 5 s/min)
- U<sub>e</sub> = 300 ... 400 V DC: Operating range with derating (20 A at max. 55°C, 16 A at max. 60°C)
- U<sub>e</sub> = 824 ... 860 V DC: Linear current derating von 1.4 A per 10 V DC
- U<sub>e</sub> = 860 ... 880 V DC: Max. 15 A
- U<sub>e</sub> = 880 ... 900 V DC: Max. 5 A
- U<sub>e</sub> > 900 V DC: The output voltage is shut down
- U<sub>e</sub> > 975 V DC can result in device damage

Figure 6-2 Derating input range from product version 2

The permissible ripple (line frequency) of the input voltage for SITOP PSU400M (between +U<sub>e</sub> and -U<sub>e</sub>) may be a maximum of 50 V<sub>pp</sub>.

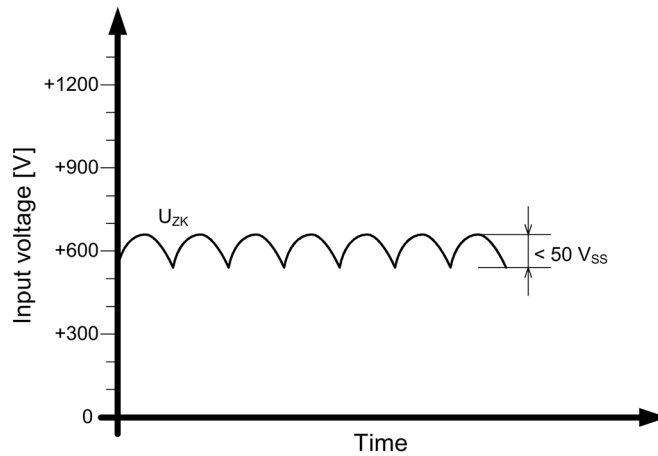

Figure 6-3 Input voltage ripple

6.1 Input

Voltage gradient of the converter DC link with respect to PE according to "CSM specification"  
10 kV/ $\mu$ s 1500 V<sub>peak</sub> max.

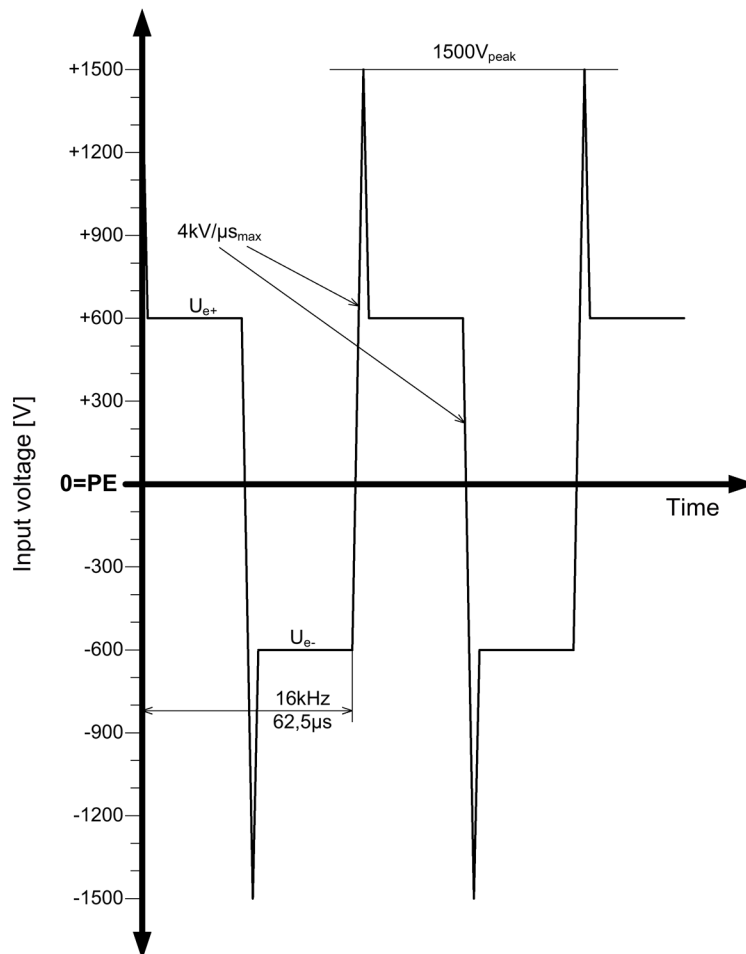

Figure 6-4 Voltage rate of rise

Hot plug in and hot plug out are not permissible!  
Maximum voltage rate of rise of the supply voltage: 1 V/ $\mu$ s

## 6.2 Output

<b>6EP1536-3AA00 (24 V/20 A)</b>	
Output	Regulated, isolated DC voltage
Rated voltage value U <sub>a</sub> rated DC	24 V
Total tolerance, static ±	3 %
Static line regulation, approx.	0,3 %
Static load regulation, approx.	0,3 %
Residual ripple peak-peak, max.	150 mV
Residual ripple peak-peak, typ.	30 mV
Spikes peak-peak, max. (bandwidth, approx. 20 MHz)	200 mV
Spikes peak-peak, typ. (bandwidth, approx. 20 MHz)	100 mV
Adjustment range	24 ... 28.8 V
Product function / output voltage can be adjusted	Yes
Output voltage setting	Via potentiometer
Operating display	LED green for 24 V O.K. LED flashing green for start delay
Signaling	Relay contact (NO contact, contact rating DC 60 V/0.3 A; DC 30 V/1 A) for "24 V O.K."
Response when switching on/off	No overshoot of U <sub>a</sub> (Soft-Start)
Starting delay, max.	0.1 s
• Remark	10 s can be set using switch C
Voltage rise, typ.	50 ms
Voltage rise time / of the output voltage / maximum	150 ms
Rated current value I <sub>a</sub> rated	20 A
Current range	0 ... 20 A
• Remark	+60 ...+70 °C derating: 5.5 % I <sub>a</sub> rated/K
Output active power / typical	480 W
Constant overload current for a short circuit when powering up, typical	40 A
Short-time overload current for a short circuit during operation, typical	60 A
Duration of the current overload capability / for a short circuit while powering up	150 ms
Duration of the current overload capability for a short circuit during operation	25 ms
Can be connected in parallel to increase the power rating	Yes
• Remark	Switchable characteristic
Number of devices that can be connected in parallel to increase the power rating, units	2
Output characteristic	See Figure 6-6 Output characteristic single operation (Page 32)

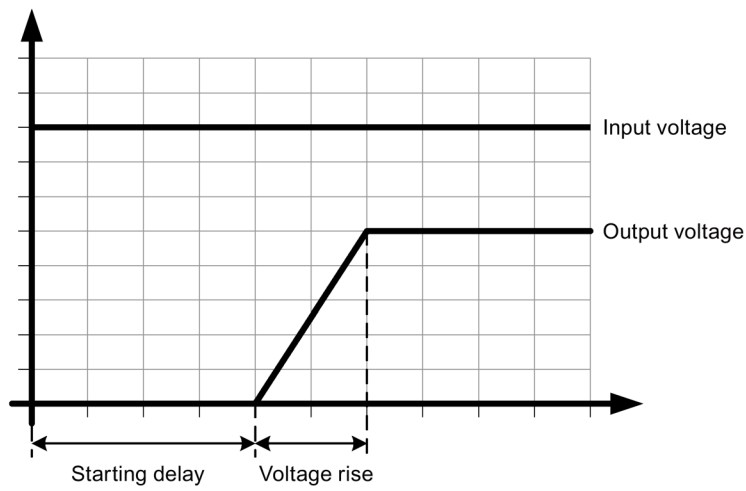

Figure 6-5 Starting delay/voltage rise

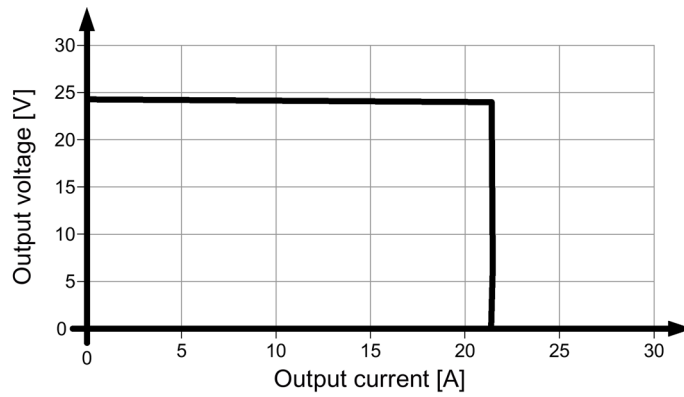

Figure 6-6 Output characteristic single operation

The device supplies a constant output voltage until the current limit is reached. If overload occurs, the output current is limited and the output voltage lowered.

**Selector switch A closed (parallel operation):**

The output voltage decreases with increasing output current.

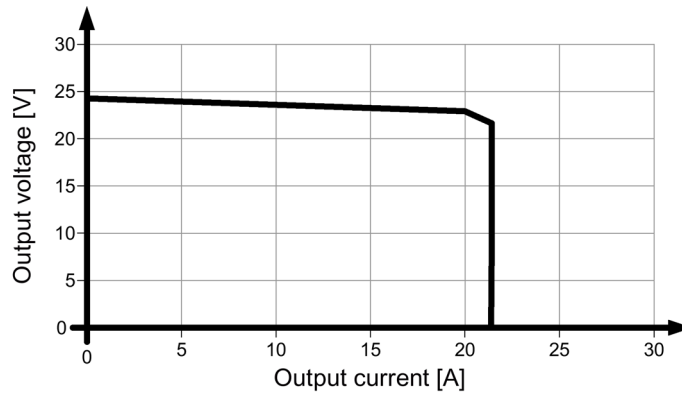

Figure 6-7 Output characteristic parallel operation

**Selector switch B closed (latching shutdown):**

The device will be shut down if the overload continues for longer than 100 ms. A reset is performed by switching the power supply OFF for at least 5 seconds.

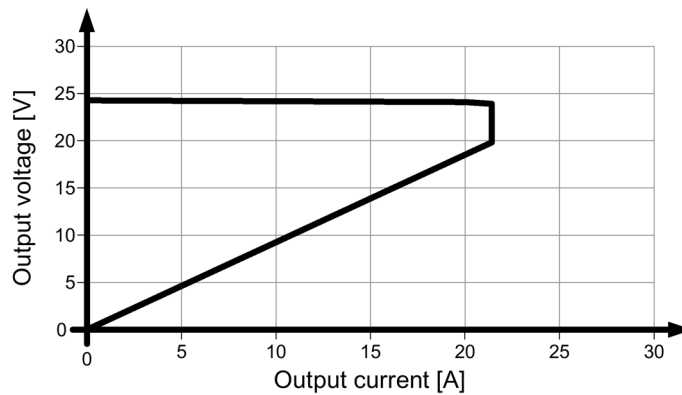

Figure 6-8 Output characteristic latching shutdown

### 6.3 Efficiency

6EP1536-3AA00 (24 V/20 A)	
Efficiency at $U_a$ rated, $I_a$ rated, approx.	95 %
Power loss at $U_a$ rated, $I_a$ rated, approx.	25 W
No-load operation power loss, approx.	10 W

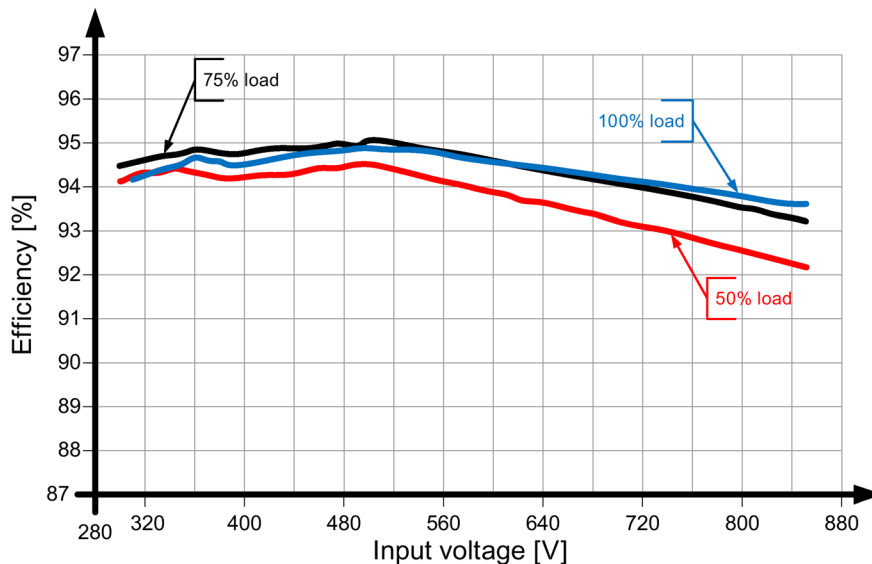

Figure 6-9 Efficiency

### 6.4 Closed-loop control

6EP1536-3AA00 (24 V/20 A)	
Dyn. line regulation ( $U_e$ rated $\pm 15$ %), max.	1,5 %
Dyn. load regulation ( $I_a$ : 10/90/10 %), $U_a \pm$ typ.	2 %
Load step regulation time 10 to 90%, typ.	1 ms
Load step regulation time 90 to 10 %, typ.	1 ms
Dyn. load regulation ( $I_a$ : 50/100/50%), $U_a \pm$ typ.	0,5 %
Load step regulation time 50 to 100 %, typ.	1 ms
Load step regulation time 100 to 50 %, typ.	1 ms
Regulation time / maximum	5 ms

## 6.5 Protection and monitoring

6EP1536-3AA00 (24 V/20 A)	
Output overvoltage protection	< 33 V
Current limitation, typ.	22 A
Property of the output/short-circuit proof	Yes
Short-circuit protection	Optional constant current characteristic approx. 22 A or latching shutdown
Continuous short-circuit current / rms value / typical	22 A
• Remark	Overload capability 150 % I <sub>a</sub> rated up to 5 s/min
Overload / short-circuit display	Yellow LED for "overload" Red LED for "latching shutdown"
Overtemperature protection	LED red flashing for "Shutdown due to overtemperature"

## 6.6 MTBF

6EP1536-3AA00 (24 V/20 A)	
Mean Time Between Failures	SN29500: >620000 hours at 40° C, rated load, 24-hour operation

## 6.7 Mechanical system

6EP1536-3AA00 (24 V/20 A)	
Connection system	Screw-type terminal
Connections / line supply	DC input "+", "-", PE: 1 screw terminal each for 0.2 ... 6 (4) mm <sup>2</sup> solid (finely stranded)
Connections / output	"+", "-", PE: 2 screw terminals each for 0.2 ... 6 (4) mm <sup>2</sup> solid (finely stranded)
Connections / auxiliary contacts	Signaling contact: 2 screw terminals for 0.14 ... 1.5 mm <sup>2</sup> solid (finely stranded)
Width of the housing	90 mm
Height of the housing	125 mm
Depth of the housing	125 mm
Mounting width	90 mm
Mounting height	225 mm
Weight, approx.	1.2 kg
Product feature / of the housing / housing that can be lined up next to one another	Yes
Type of mounting / panel mounting	No

---

6EP1536-3AA00 (24 V/20 A)	
Type of mounting / rail mounting	Yes
Type of mounting / S7-300 rail mounting	No
Mounting	Can be snapped onto standard EN 60715 35x7,5/15 mounting rails

---

## 6.8 Accessories

---

6EP1536-3AA00 (24 V/20 A)	
Electrical accessories	Buffer module
Mechanical accessories	Device identification labels 20 mm × 7 mm, pastel turquoise 3RT1900-1SB20

---

## 6.9 Dimension drawing

See Section Dimensions and weight (Page 16)

CAD data that can be downloaded from the Internet:

6EP1536-3AA00

([http://www.automation.siemens.com/bilddb/index.aspx?objKey=G\\_KT01\\_XX\\_00668](http://www.automation.siemens.com/bilddb/index.aspx?objKey=G_KT01_XX_00668))

## Safety, approvals, EMC

### 7.1 Safety

<b>6EP1536-3AA00 (24 V/20 A)</b>	
Primary/secondary galvanic isolation	Yes
Electrical isolation	SELV output voltage Ua according to EN 60950-1 and EN 50178
Protection class	Class I
Degree of protection (EN 60529)	IP20
Leakage current, typ.	-
Leakage current, max.	-
Test voltage	See Test voltage (Page 38)

## 7.2 Test voltage

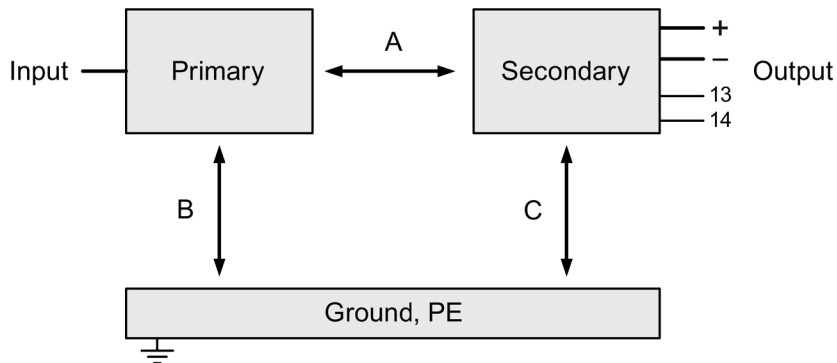

Figure 7-1 Test voltage diagram with auxiliary contact

Only the manufacturer can perform the type test and production test; users can also perform the field test.

Preconditions for performing the field test:

Tests (A) & (B)

- Connect the input terminals with one another
- Connect the output terminals, signaling contact and PE with one another

Test (C)

- Connect the output terminals and signaling contact with one another and measure with respect to PE

Table 7- 1 Test voltage

	Test time	Prim ↔ sec (A)	Prim ↔ PE (B)	Sec ↔ PE (C)
Type test	60 s	4200 VDC	2200 VDC	700 VDC
Production test	1 s	2200 VDC	2200 VDC	500 VDC
Field test	1 s	2200 VDC	2200 VDC	500 VDC

Remark:

Tripping current for DC measurement: 0 mA

## 7.3 Approvals

6EP1536-3AA00 (24 V/20 A)	
CE marking	Yes
UL/cUL (CSA) approval	cULus-Listed (UL 508, CSA C22.2 No. 107.1), File E197259
Explosion protection	-
CB approval	Yes
Marine approvals	GL

## 7.4 EMC

6EP1536-3AA00 (24 V/20 A)		
Electrostatic discharge	EN 61000-4-2	8 kV contact, 8 kV air
Electromagnetic fields	EN 61000-4-3	80 ... 1000 MHz 20 V/m 1000 ... 2000 MHz 3 V/m 2000 ... 2700 MHz 1 V/m
High-speed transient disturbance variables (burst)	EN 61000-4-4	4 kV at line supply connections 2 kV at the DC output
Surge voltages	EN 61000-4-5	1 kV symmetrical at the line connections (with converter) 6 kV unsymmetrical at the line connections (primary PE) 500 V symmetrical/unsymmetrical at DC output cables
High-frequency fields	EN 61000-4-6	20 V; 0.15 ... 80 MHz 3 V; 1.0 ... 2 GHz 1 V; 2.0 ... 2.7 GHz
Magnetic fields	EN 61000-4-8	30 A/m; 50 Hz
Voltage dips	EN 61000-4-11	-
Voltage interruptions	EN 61000-4-11	-
Emitted interference	EN 55022	Class A
Line harmonics limit	EN 61000-3-2	-
Generic standards	EN61000-6-2	Noise immunity for industrial environments
	EN61000-6-3	-



## Ambient conditions

6EP1536-3AA00 (24 V/20 A)	
Ambient temperature	-25°...+70° C with natural convection Tested according to: <ul style="list-style-type: none"> <li>• EN 60068-2-1 cold</li> <li>• EN 60068-2-2 dry heat</li> <li>• EN 60068-2-78 humid heat, constant</li> <li>• EN 60068-2-14 temperature change</li> </ul>
Transport and storage temperature	-40 ...+85 °C Tests (packed for shipping) according to: <ul style="list-style-type: none"> <li>• EN 60068-2-1 cold</li> <li>• EN 60068-2-2 dry heat</li> <li>• EN 60068-2-30 humid heat, cyclic</li> </ul>
Humidity class	Climatic class 3K3 according to EN 60721, without condensation
Degree of pollution	2
Mechanical stressing during operation	<ul style="list-style-type: none"> <li>• Tested according to EN 60068-2-6 vibration, test Fc: 3.5 mm deflection in the range 5 ... 8.4 Hz 2 g acceleration in the range 8.4 ... 150 Hz</li> <li>• Tested according to EN 60068-2-27 shock, test Ea: acceleration 150 m/s<sup>2</sup>, test duration 11 ms</li> </ul>
Damaging gases	Tested according to: <ul style="list-style-type: none"> <li>• EN 60068-2-42 sulfur dioxide</li> <li>• EN 60068-2-43 hydrogen sulfide</li> </ul>
Atmospheric pressure	Operation: <ul style="list-style-type: none"> <li>• 1080 ... 795 hPa (-1000 ... +2000 m)</li> <li>• For operation at altitudes of 2000 m up to 6000 m above sea level: output must be derated by -7.5% / 1000 m or the ambient temperature must be reduced by 5 K / 1000 m see Figure 4-2 Mounting height derating (Page 19)</li> <li>• Overvoltage category: III up to 2000 m (EN 50178) II from 2000 m up to 6000 m (EN 50178)</li> </ul> Storage: <ul style="list-style-type: none"> <li>• 1080 ... 660 hPa (-1000 ... +3500 m)</li> </ul>



## Applications

### 9.1 Parallel connection to increase the power rating

To increase the power rating, SITOP PSU400M power supplies of the same type can be directly connected in parallel.

The following must be observed:

- The cables connected to each power supply at terminals "+" and "-" must have identical lengths and the same cable cross-sections (or the same impedance) up to a common external connection point (terminal strip) if possible.
- The power supplies connected in parallel must be switched on simultaneously with a common switch in the line feeder cable (e.g. with the main switch available in control cabinets).
- The output voltages measured in no-load operation for the power supplies that are not yet connected in parallel should not deviate more than a maximum of 50 mV. This usually corresponds to the factory setting. If the output voltage is changed, you should connect the "-" terminals and then, in no-load operation, measure the voltage difference between the "+" terminals that have not yet been connected. The voltage difference should not exceed 50 mV.

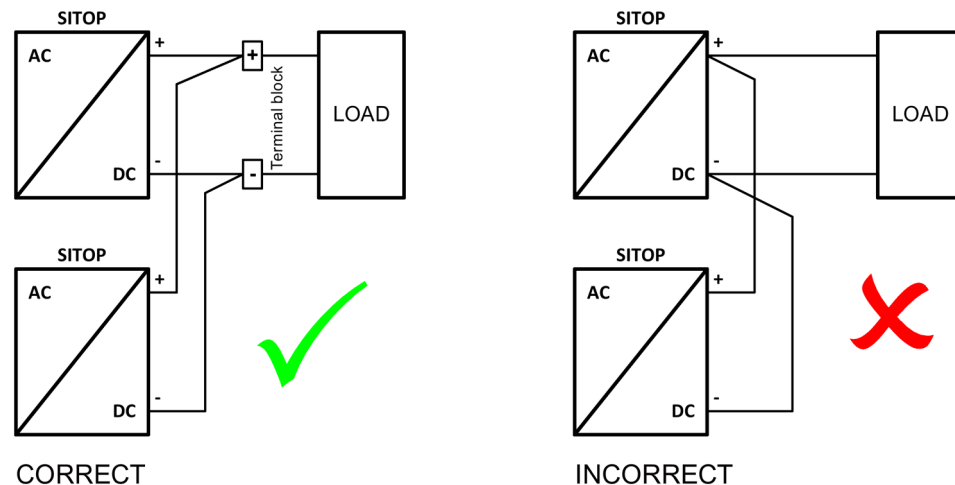

Figure 9-1 Parallel connection

#### Note

It is not permissible to take into account simultaneous overload capability (Extra-Power 150% for 5 s/min) of several power supplies connected in parallel when configuring the power supply system.

**NOTICE**

**Protective circuit for the parallel connection of more than two power supplies**

When connecting more than two power supplies in parallel, additional measures must be taken to prevent high backward feeding currents in the event of a secondary device fault. For this purpose, a suitable protective circuit (e.g. decoupling diode or DC-conform circuit breaker) must be installed between each "+" terminal of the power supply and the common connection point.

## 9.2 Parallel connection for redundancy

Connecting several SITOP PSU400M power supplies in parallel for redundancy purposes is required if especially high demands are placed regarding the availability of a reliable 24 V power supply.

Using the SITOP PSE202U redundancy module, two power supplies of the same type up to 20 A can be decoupled (Figure 9-2 Redundant configuration with two power supplies and SITOP PSE202U redundancy module (Page 45)). When one of the devices fails, then the other automatically takes over the power supply. If one of the power supplies fails, then this is signaled using an LED on the redundancy module as well as an isolated relay contact. When dimensioning the system, it must be ensured that  $n+1$  redundant connected power supplies can handle the total power requirement of the remaining  $n$  power supplies.

---

### Note

For a high reliability of the supply, it is recommended that the redundant switched power supplies are fused separately on the line-side and, if possible, be connected to different power supply networks.

---

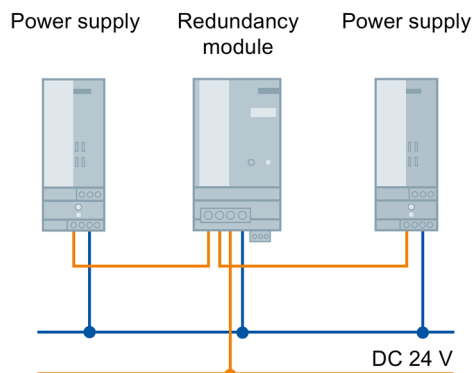

Figure 9-2 Redundant configuration with two power supplies and SITOP PSE202U redundancy module

You can find additional information at:

SITOP PSE202U manual (<http://support.automation.siemens.com/WW/view/en/42248598>)

### 9.3 Series connection for increased voltage

To achieve an output voltage of 48 V DC, two SITOP PSU400M power supplies of the same type can be connected in series. In this case, connect the "-" terminal of the first power supply to the "+" terminal of the second power supply. The "+" terminal of the first power supply and the "-" terminal of the second power supply are routed to the load.

Depending on the grounding point of the secondary output voltages, voltages of +48 V,  $\pm 24$  V or -48 V can be realized.

In the case of an asymmetric load distribution, it is not possible to guarantee correct functionality.

 <b>WARNING</b>
<b>SELV is not guaranteed in the case of a fault</b>
When connecting two power supplies in series, the continuous, permissible SELV voltage of a maximum of 60 V DC according to EN 60950 cannot be guaranteed in the case of a fault.

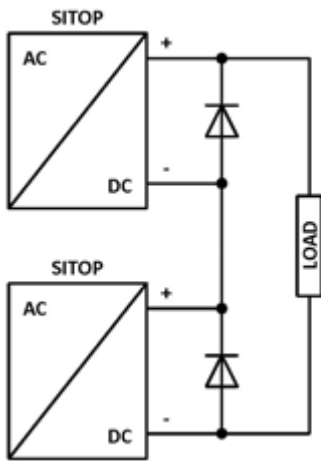

Figure 9-3 Series connection

## 9.4 Overload protection in the 24 V output circuit

If an overload occurs, the electronic current limiting function limits the SITOP PSU400M output current to a maximum value (see Section Technical data (Page 27)). The output cables are protected against a thermal overload if they are dimensioned corresponding to the maximum rms output current, or protected using additional components (for example, miniature circuit breaker, fuses).

However, a load circuit that fails as a result of overload, for instance, should frequently be reliably and quickly identified and specifically switched off before the power supply goes into current-limiting mode (in current-limiting mode, the supply voltage would also be reduced for all of the remaining 24 V loads).

The SITOP PSE200U selectivity module with 4 outputs (versions with adjustable output current range for each output from 0.5 .. 3 A and 3 ... 10 A) is available for this purpose; this monitors the 24 V branches for overload and short circuit (Figure 9-4 Electronic protection of 24 V loads using the SITOP PSE200U selectivity module (Page 47)). Brief current peaks, e.g. as a result of a high inrush current, are permitted, and branches with a longer overload are switched into a no-current condition. This is also ensured for cables in a high-ohmic condition and for short circuits that slowly develop over time.

When an output fails, the fault is signaled using a group signal contact or as a single channel signal, and the branch of the module involved is displayed using an LED.

For variants with single-channel signaling, function blocks for evaluation purposes are available for SIMATIC S7-1200/1500/300/400, for STEP 7 Classic and TIA Portal at no charge.

You can find additional information at:

SITOP PSE200U selectivity module manuals

(<http://support.automation.siemens.com/WW/view/en/42248598>)

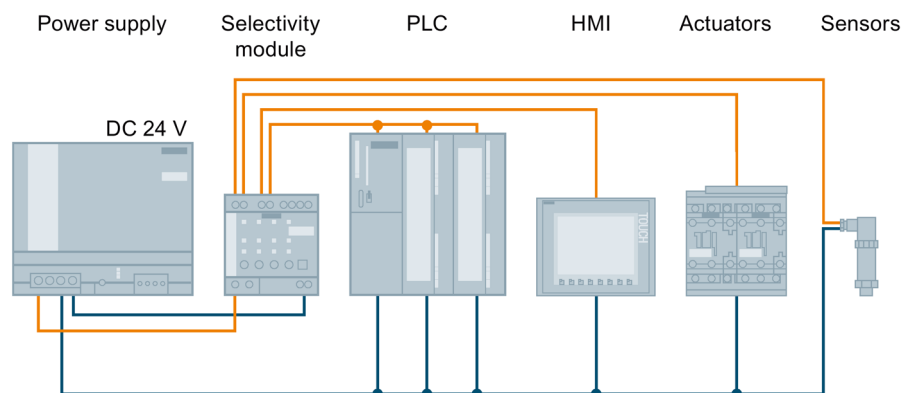

Figure 9-4 Electronic protection of 24 V loads using the SITOP PSE200U selectivity module

## 9.5 Protection against short-time voltage dips

For line supplies that manifest frequent brief voltage dips, in order to increase the power supply reliability, it may make sense to use a SITOP PSE201U buffer module.

The SITOP PSE201U buffer module, based on electrolytic capacitors, is connected in parallel to the power supply output (Figure 9-5 Buffering brief power failures using the SITOP PSE201U buffer module (Page 48)). The buffer time is 200 ms at 40 A up to 1.6 s for a load current of 5 A. This time can be increased a multiple number of times by connecting buffer modules in parallel; the maximum buffer time is 10 s.

You can find additional information at:

SITOP PSE201U manual (<http://support.automation.siemens.com/WW/view/en/42248598>)

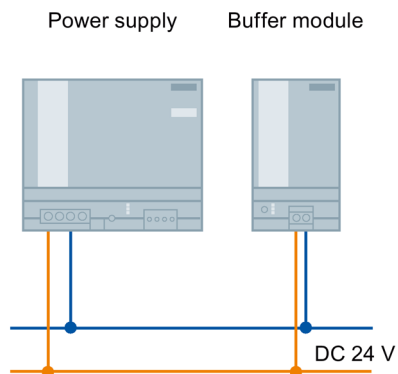

Figure 9-5 Buffering brief power failures using the SITOP PSE201U buffer module

## 9.6 Protection against longer failure of the power supply voltage

Sudden and longer failures of the line supply voltage can result in undefined states and significant danger as a result of the associated failure of the plant or system control. The SITOP power supply product portfolio includes various DC-UPS solutions to prevent the failure of the 24 V power supply voltage.

Power supply failures up into the minutes range can be buffered using the maintenance-free SITOP UPS500 DC-UPS modules based on capacitors (Figure 9-6 24 V buffering to allow the saving of process data and controlled shutdown of PCs (Page 49)).

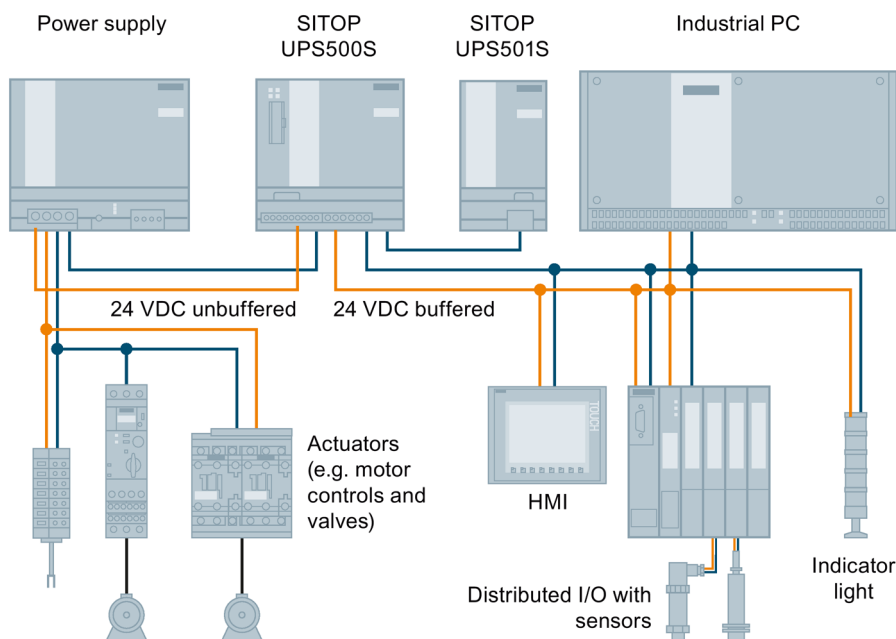

Figure 9-6 24 V buffering to allow the saving of process data and controlled shutdown of PCs

Using the free-of-charge SITOP DC-UPS software tool, DC-UPS systems can be simply integrated into PC-based automation solutions. This supports further processing of the status signals and safely running down the PC.

You can find additional information at:

Manual, DC UPS with capacitors

<http://support.automation.siemens.com/WW/view/en/48932766/133300>

9.6 Protection against longer failure of the power supply voltage

Using DC UPS SITOP UPS1600 and SITOP UPS1100 battery modules, buffer times in the range of hours can be implemented. Intelligent battery management using Energy Storage Link automatically detects the UPS1100 energy storage device, and ensures optimum temperature-controlled charging and continuous monitoring. The UPS1600 can be flexibly integrated into the widest range of automation applications with its digital inputs/outputs as well as optional USB interface or Ethernet/PROFINET port.

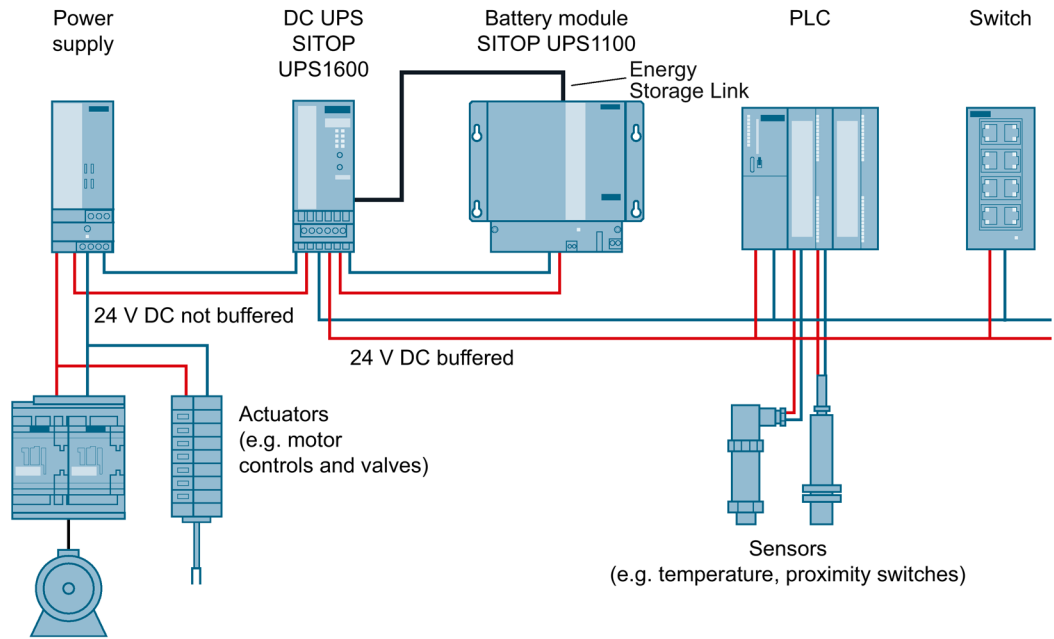

Figure 9-7 24 V buffering with SITOP UPS1600 to maintain communication, signaling functions, sensor measured values and position values

For open, PC-based automation systems, configuration and monitoring is realized using the SITOP UPS Manager PC software, which is available at no charge. This allows PC responses to the operating states of the DC UPS to be freely selected – and offers comprehensive diagnostic functions.

For TIA-based automation systems, the UPS1600 is engineered using the TIA Portal. Special function blocks for SIMATIC S7-300/400/1200 and S7-1500 – available at no charge – make it easy to integrate operating and diagnostics information into STEP 7 user programs. Preconfigured UPS faceplates for WinCC visualization can be downloaded at no charge.

You can find additional information at:

DC UPS SITOP UPS1600/UPS1100 Manual  
<http://support.automation.siemens.com/WW/view/en/84977415>

## Environment

The devices are in conformance with RoHS.

As a rule, only non-silicon precipitating materials are used.

### Disposal guidelines



Packaging and packaging aids can and should always be recycled. The product itself may not be disposed of as domestic refuse.



## Service & Support

### Technical support

Technical support for all IA/DT products can be accessed through the following communication channels:

- Phone: + 49 (0) 911 895 7222
- E-Mail (<mailto:support.automation@siemens.com>)
- Internet:  
Online support request form (<http://www.siemens.de/automation/support-request>)

### Technical documentation on the Internet

Operating instructions and manuals for SITOP are available in the Internet:  
Operating instructions/manuals (<http://www.siemens.de/sitop/manuals>)

### SITOP power supply homepage

General news about our power supplies is available in the Internet at the SITOP homepage:  
SITOP (<http://www.siemens.de/sitop>)

### Information material

SITOP information can be downloaded from the Internet:  
Information and download center (<http://www.siemens.de/sitop-infomaterial>)

### CAX data

2D/3D data and circuit diagram macros can be downloaded from the Internet:  
Siemens image database (<http://www.siemens.de/sitop-cax>)

Request all CAX data via the CAX download manager:  
CAX shopping cart (<http://www.siemens.de/cax>)

### SITOP Selection Tool

Simply and quickly select the optimum the power supply or DC-UPS:  
SITOP Selection Tool (<http://www.siemens.de/sitop-selection-tool>)

### Online catalog and ordering system

The online catalog and the online ordering system are available through the Industry Mall homepage:  
Industry Mall (<http://www.siemens.com/industrymall/de>)

**Contact persons**

If you have any questions regarding the use of our products, then contact the Siemens contact person in your regional Siemens sales office.

You can find these addresses as follows:

- On the Internet (<http://www.siemens.de/automation/partner>)
- In Catalog CA 01