



AdderLink X-Series

Gold Extender



[CONTENTS](#)

Contents



Welcome

Introduction	2
Supplied items	3

Installation and operation

Installation	4
Stage A - Configuration switch settings	4
LOCAL module switches	4
REMOTE module switches	5
Stage B - Mounting a module – desk or rack	6
Stage C – Connections	7
Connections at the LOCAL module	7
Connections at the REMOTE module	8
Operation	9
Power and activity indicators	9
General use	9
Locking and unlocking the system	9

Special configuration

Configuration	10
What are hotkeys?	10
Entering, using and exiting configuration mode	10
Password setting	11
Password override	11
Hot plugging and mouse restoration	12
Which restore setting do I use?	12
Microsoft and Logitech -specific mouse settings	12
Video compensation	13
The Skew Compensator	14
Miscellaneous settings	14
Flash upgrade	15
Stage A - Download the upgrade files	15
Stage B - Create a startup diskette	15
Stage C - Reconfigure the LOCAL connections and begin .	16
Stage D - Reconfigure the REMOTE connections and begin .	16
Stage E - Return all connections to their usual states	16

Further information

Troubleshooting	17
Getting assistance	17
Other products in the X-Series range	18
Safety information	18
Warranty	18
Radio Frequency Energy	19

Welcome



Introduction

Thank you for choosing the AdderLink X-Series Gold Extender set which allows you to place the controlling keyboard, video monitor, mouse, audio accessories (and also a serial device) up to 200 metres from a system. The X-Series Gold Extender set consists of two modules: a local module that attaches to your computer system and a remote module to which the peripherals are connected. The long distance link between the two modules is made via Category 5, or higher, twisted pair cabling.

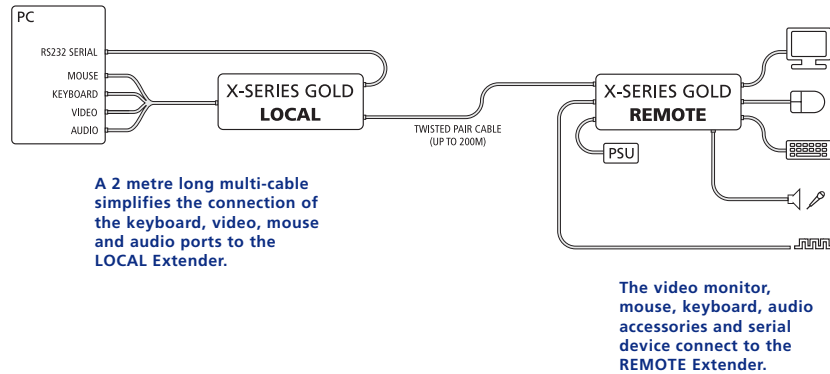

Internal circuitry within the remote module ensures crisp video images by automatically compensating for the length of the twisted pair cable run.

CONTENTS

WELCOME

INSTALLATION
& OPERATION

SPECIAL
CONFIGURATION

FURTHER
INFORMATION

Supplied items

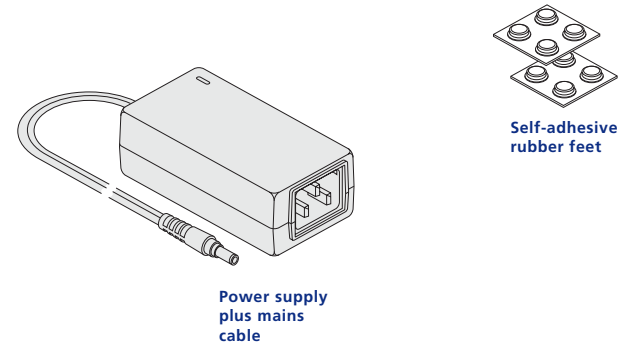
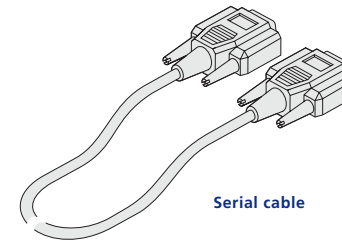
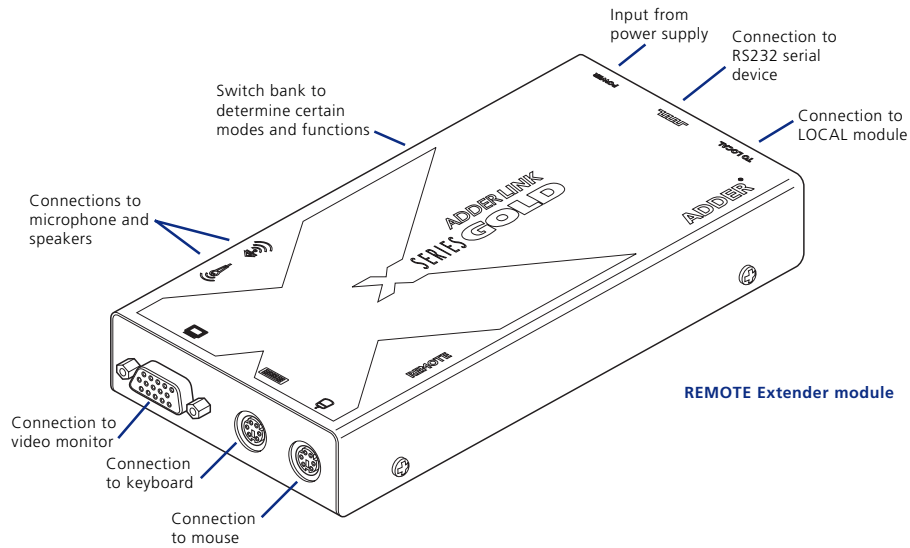
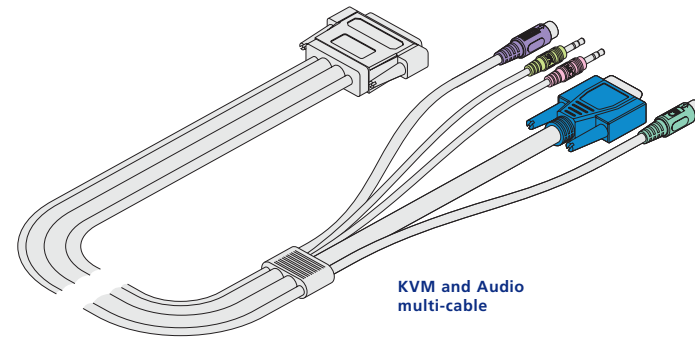
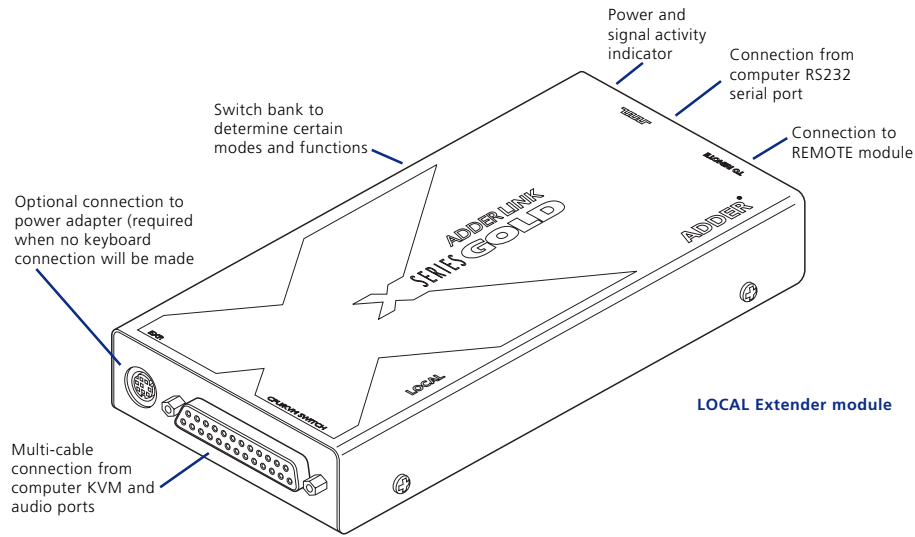

CONTENTS

WELCOME

INSTALLATION & OPERATION

SPECIAL CONFIGURATION

FURTHER INFORMATION

Installation and operation



Installation

The installation of the Gold Extender set is straightforward and can best be achieved in most cases by following these stages for each module:

- **Stage A** Check or set the configuration switch settings
- **Stage B** Mount the module
- **Stage C** Connect the cables

Stage A - Configuration switch settings

The basic operation of the LOCAL and REMOTE modules are controlled by the banks of four switches located on the side of each module. The switches are monitored at all times and may be changed when power is on or off (the only exception to this rule is switch 1 of the LOCAL module which initiates slightly different functions depending on the power state when it is switched).

LOCAL module switches

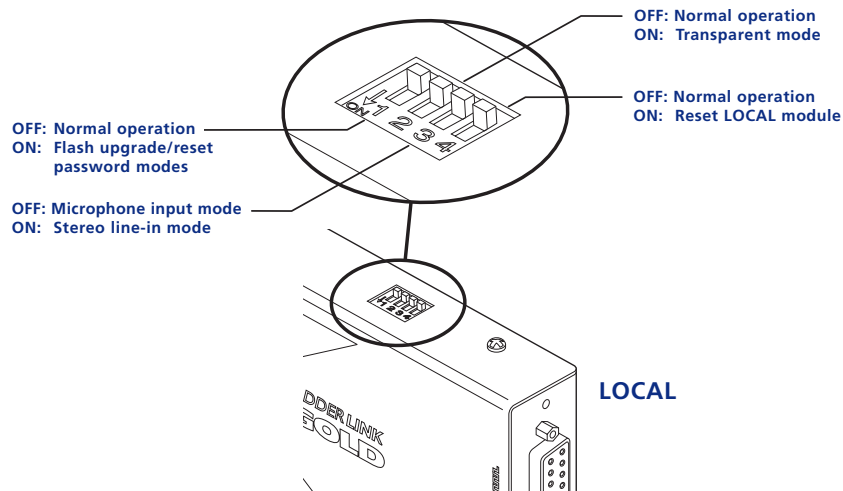

Note: When shipped, all switches are set in the OFF positions and this will produce normal operation with normal microphone input (at the REMOTE module).

LOCAL module switches (continued)

LOCAL Switch 1

OFF: Normal operation.

ON: (Before power is applied) Places the LOCAL module into flash upgrade mode so that the internal software can be changed. Please see the 'Flash upgrade' section in the 'Special configuration' section.

ON: (Whilst power is applied) Places the REMOTE module into password override mode. This allows any pre-configured passwords to be altered - particularly useful when they have been lost or forgotten. Please see the 'Password override' section in the 'Special configuration' chapter.

LOCAL Switch 2

OFF: Normal operation.

ON: Set transparent mode. Use this setting if the GOLD modules are to be used with KVM switches that are not manufactured by Adder Technology. Cascaded KVM switches often use special signals to set or identify conditions. In transparent mode, the GOLD modules will pass the signals without attempting to interpret them.

LOCAL Switch 3

OFF: Microphone input on REMOTE module. Use this setting if a standard mono-channel microphone is connected to the MIC input on the REMOTE unit.

ON: Stereo line-in input on REMOTE module. Use this setting if a stereo input is applied to the MIC input on the REMOTE unit.

LOCAL Switch 4

OFF: Normal operation.

ON: Suspend operation and reset the LOCAL module. Use this setting momentarily to produce the same effect as removing and restoring power if incorrect operation has occurred. Return the switch to the OFF position to allow normal operation to continue.

REMOTE module switches

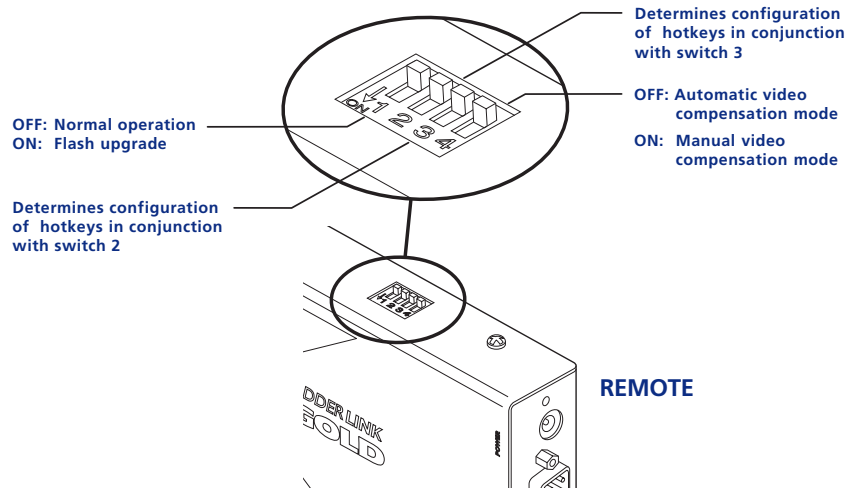

Note: When shipped, all switches are set in the OFF positions and this will produce normal operation.

REMOTE module switches (continued)

REMOTE Switch 1

OFF: Normal operation.

ON: (Before power is applied) Places the REMOTE module into flash upgrade mode so that the internal software can be changed. Please see the 'Flash upgrade' section in the 'Special configuration' chapter.

REMOTE Switches 2 and 3

Switches 2 and 3 determine which two keyboard keys (when pressed in unison) are to be designated as 'hotkeys'. Hotkeys signal to the REMOTE module that the next key to be pressed is a special configuration command for the module and is not to be passed to the computer system.

2 OFF Hotkeys = CTRL and SHIFT
3 OFF

2 OFF Hotkeys = ALT and SHIFT
3 ON

2 ON Hotkeys = CTRL and ALT
3 OFF

2 ON Hotkeys disabled
3 ON

REMOTE Switch 4

OFF: Automatic video compensation mode. In this mode circuitry within the REMOTE module will adjust the video compensation settings automatically at power on to match the length of the cable run (providing the twisted pair to both modules is connected and both modules are switched on).

ON: Manual video compensation mode. Use this mode to bypass the automatic compensation circuitry if manual adjustment is required to improve the video quality. Automatic video compensation disabled. Please see the 'Video compensation' section in the 'Special configuration' chapter.



Stage B - Mounting a module – desk or rack

The Gold Extender modules can be situated on a desk (or floor) or alternatively, for larger installations, mounted within optional rack mount chassis units.

Desk mount

Apply the supplied self-adhesive rubber feet to the underside of the module(s).

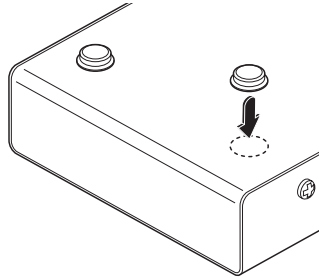

Rack mount

Note: The module switches are not accessible once it is inserted into the rack, therefore, check all settings before insertion.

- 1 Place the rack securing plate (available as a separate kit) onto the front of the module and secure it with the two countersunk screws.
- 2 Orient the module on its side so that its labelled face is the correct way up and the securing plate is facing away from the rack.
- 3 Slide the module into the required rack position. The rectangular cut-out in the front upper lip of the rack allows the two screws on the module's upper edge to slide through.
- 4 The rack mount chassis has a series of holes in its floor that are spaced to accommodate the two screws on the module's lower edge. Ensure that the screws correctly locate into the two holes of the chosen slot. The rack securing plate on the module should now be flush with the front of the rack mount chassis.
- 5 Use the third (pan-head) screw, in the top hole of the rack securing plate to fasten the module to the rack.

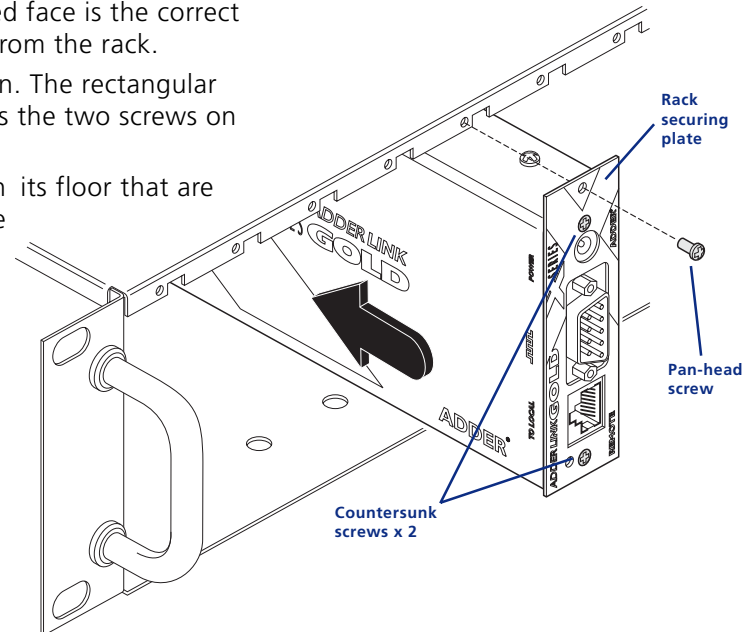

Stage C – Connections

The naming of the LOCAL and REMOTE modules relate to their proximity to the computer system. Hence, the LOCAL module connects directly to the system, while the REMOTE is at the other end of the twisted pair cable and attaches to the keyboard, mouse, etc.

Connections at the LOCAL module

KVM+A multi-cable connection





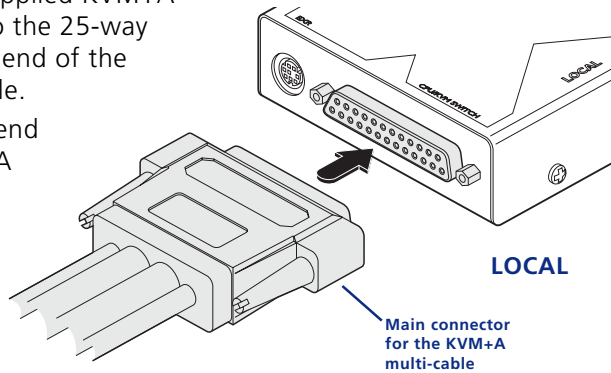

Most of the connections between the computer system and the LOCAL module are made via the supplied multi-cable. This has a single connection to the module, is two metres in length and splits out to the keyboard, video, mouse, microphone and speaker ports of the system.

- 1 Attach the supplied KVM+A multi-cable to the 25-way socket at the end of the LOCAL module.

- 2 At the other end of the KVM+A cable, attach the keyboard, mouse and video, microphone and speaker



connectors to the appropriate sockets at the rear of the computer system. On most systems the appropriate ports should be labelled and colour coded in a similar way to the cable connectors:

Monitor (video)			Blue
Keyboard			Purple
Mouse	 or 		Mid green
Speaker	 or SPK		Light green
Microphone	 or MIC		Pink (or maroon)

Serial cable connection

The Gold Extender set offers the option to attach an RS232 serial device (such as a touch screen input) via the remote link. The link supports software or hardware handshaking up to a maximum baud rate of 56Kb/s. To make the serial connection between the LOCAL module and your computer system, use the supplied serial link cable.

- 1 Attach male connector of the serial link cable to the 9 pin port on the LOCAL module, labelled .

- 2 Connect the other end of the serial link cable to the appropriate serial port of the computer system.

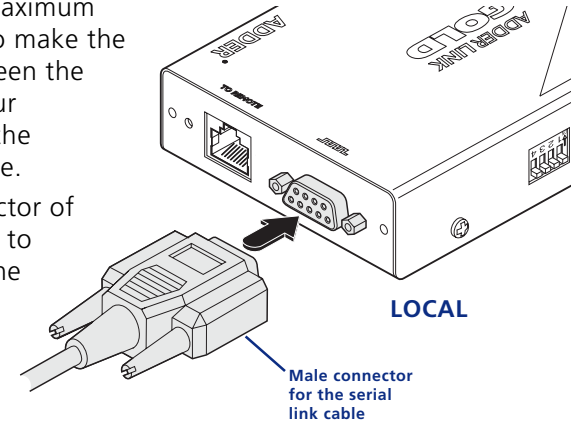

Twisted pair connection

The link between the LOCAL and REMOTE modules is made via twisted pair cable, specified to Category 5 or higher. Ensure that the total twisted pair cable length (including patch boxes) does not exceed 200 metres.

- 1 Insert the connector from the twisted pair cable link into the socket marked 'TO REMOTE'.

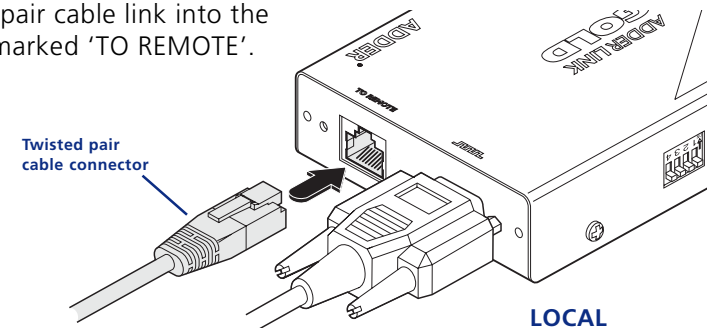

Connections at the REMOTE module

Keyboard, video and mouse connections

The connections to the keyboard, video monitor and mouse are all made to the sockets at one end of the REMOTE module.

- 1 Attach the lead from the monitor to the blue D-type socket labelled on the REMOTE module.
- 2 Connect the keyboard lead to the purple mini-DIN socket labelled on the REMOTE module.
- 3 Insert the keyboard lead into the green mini-DIN socket labelled on the REMOTE module.

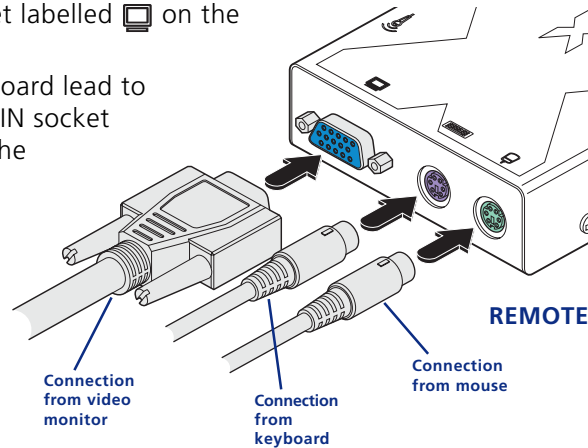

Twisted pair, power and serial connections

- 1 Insert the connector from the twisted pair cable link into the socket marked 'TO LOCAL'.
- 2 Attach the output connector of the power supply to the socket at the front edge of the REMOTE module labelled POWER.
- 3 Insert the IEC connector of the supplied power lead into the corresponding socket of the power supply. Connect the other end of the power lead to a nearby mains socket.
- 4 If the serial connection to be used, attach the lead from your serial device to the 9 way male connector on the REMOTE module labelled .

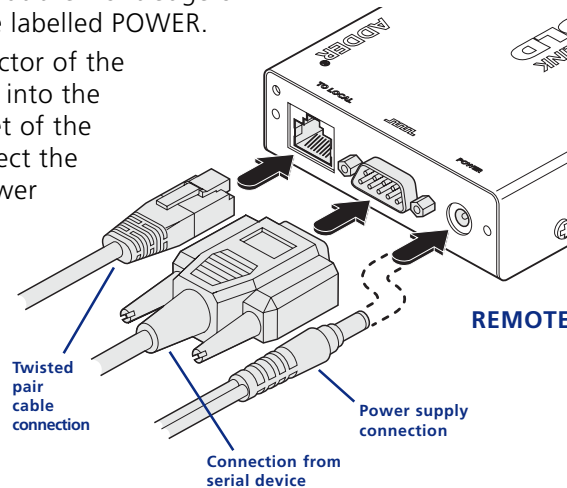

Audio connections

Audio connections are available at the two 3.5" jack sockets mounted on the side (same side as the switch bank) of the REMOTE module.

Note: The microphone input (labelled) has a dual function whereby it can either support a mono-channel microphone or alternatively receive stereo line input. Switch 3 on the LOCAL module controls the setting of this port: LOCAL switch 3 OFF - microphone, LOCAL switch 3 ON - stereo line in.

- 1 Connect the microphone (or stereo line input) plug to the REMOTE module socket labelled .

Note: Ensure that the setting of switch 3 on the LOCAL module matches the input to this socket: OFF-microphone; ON-stereo line input).

- 2 Connect the speaker plug to the socket labelled .

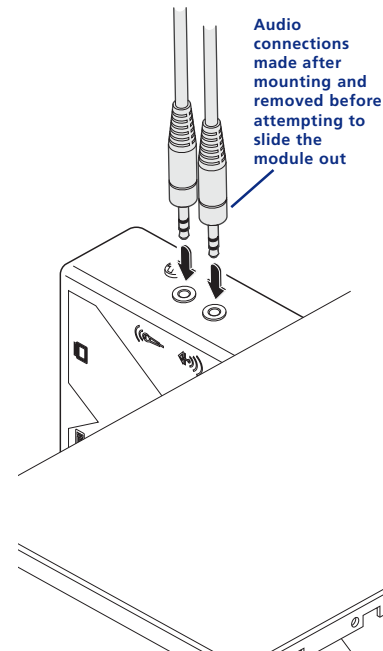
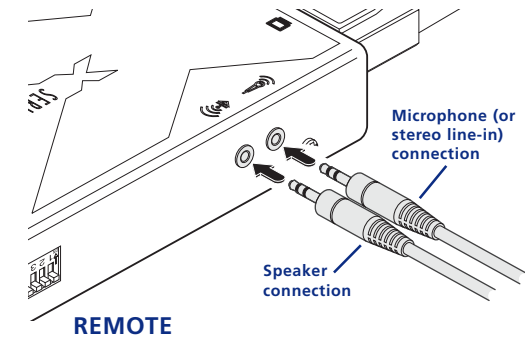

Note: When the REMOTE module is rack mounted, the audio connections must be made after the module has been fixed in place. Access is required to the rear and above the rack. Remember to remove the audio connections before attempting to slide out the REMOTE module.

Operation

Power and activity indicators

On the front panel of both modules are small recessed indicators which provide confirmation of power and activity, as follows:

- Constant red - power applied, no communication activity.
- Flickering red - power applied, mouse or keyboard activity occurring.
- Slow flashing red - module is in flash upgrade mode.

Note: Both modules contain internal automatic cut-out fuses to protect against power surges. To reset, remove power (or, for the LOCAL module, the keyboard connection) from the module for one second and then reconnect.

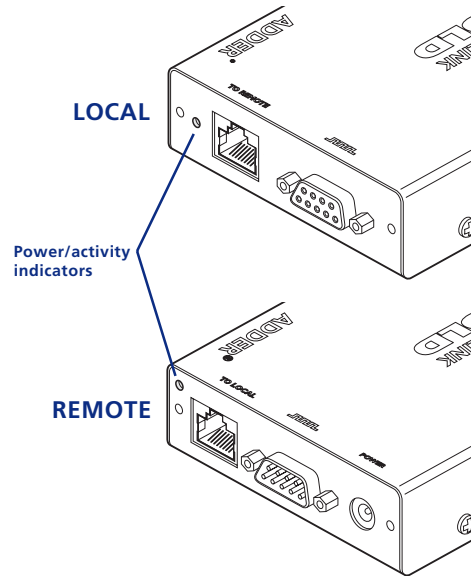

General use

In use, the Gold Extender modules should be transparent - the system and its peripherals should operate exactly as normal, the only difference being that they are now up to 200 metres apart.

In some installations, you may see some 'shadows' to the right of high contrast screen characters. This is caused by an incorrectly selected video compensation setting. In the majority of cases the automatic video compensation circuitry will correct such occurrences. However, it may be necessary to manually adjust the video compensation settings or in extreme cases to install an optional correction module. Please see the 'Video compensation' section in the 'Special configuration' section.

Locking and unlocking the system

In situations where the computer system (and the LOCAL module) can be locked away the Gold Extender set offers a viable security system to deter unauthorised use. Once a password has been set, a simple key sequence allows the system to be quickly and securely detached from its peripherals. Only the correct password will reconnect the remote and local modules.

To lock the system

- 1 First set a password. For further details, please refer to the 'Password setting' section in the 'Special configuration' chapter.
- 2 Simultaneously press the currently configured hotkeys (by default, **Ctrl** and **Shift**) along with **L**.

The screen will go blank and the three keyboard indicators will begin alternately flashing between the 'Num Lock' and 'Scroll Lock', and 'Caps Lock'. This sequence indicates that a password is required.

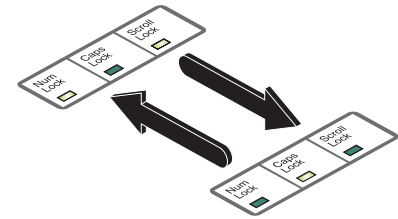

To unlock the system

- 1 Enter the correct password and press **Enter**.

Note: Passwords are NOT case sensitive.

Note: If an invalid password has been entered and the keyboard indicators are not flashing as described above, press **Enter** to clear the incorrect attempt.

- 2 If the correct password is entered, the screen will be restored and normal operation can continue.

To enable the video

Simultaneously press the currently configured hotkeys (by default, **Ctrl** and **Shift**) along with **F1**. This command will be required to restore the video if **Ctrl** and **Shift** along with **L** is used when no password has been set.

To disable the video

Simultaneously, press the currently configured hotkeys (by default, **Ctrl** and **Shift**) along with **O**.

Special configuration

Configuration

You can alter the way that the Gold Extender modules operate to suit your requirements. This is done using the Configuration mode and you can affect the following settings:

- *Password setting* – allows you to lock the remote module to prevent unauthorised system access.
- *Mouse restoration and settings* – allows you to restore mouse operation and also to change the mouse type.
- *Video compensation* – allows you to manually adjust the video compensation settings.
- *Miscellaneous functions*.

What are hotkeys?

Hotkeys are two normal keyboard keys that, when pressed simultaneously with a third key, signal to the Gold Extender modules that you are sending a message specifically to them and not to the computer. The hotkeys are ordinarily **Ctrl** and **Shift**, while the third key determines what you want the modules to do.

If the standard **Ctrl** and **Shift** hotkeys are also needed for computer tasks, you can change them for another combination using switches 2 and 3 on the REMOTE module:

- | | | |
|-------|-------|--|
| 2 OFF | 3 OFF | Hotkeys = Ctrl and Shift (default setting) |
| 2 OFF | 3 ON | Hotkeys = Alt and Shift |
| 2 ON | 3 OFF | Hotkeys = Ctrl and Alt |
| 2 ON | 3 ON | Hotkeys disabled |

Entering, using and exiting configuration mode

To enter and use configuration mode:

- 1 Simultaneously press the currently configured hotkeys (by default, **Ctrl** and **Shift**) along with **F1**.

The three keyboard indicators ('Num Lock', 'Caps Lock' and 'Scroll Lock') will now begin to flash in sequence to show that you are in configuration mode.

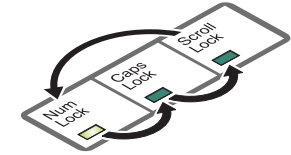

- 2 Press the first letter of the required configuration option, for instance **F**.

All three keyboard indicators will illuminate continuously.

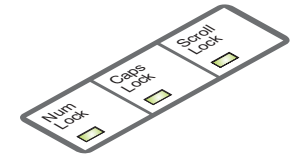

- 3 Press the number of the required configuration option, for instance **8**.

The 'Scroll Lock' indicator will extinguish, leaving the 'Num Lock' and 'Caps Lock' indicators lit.

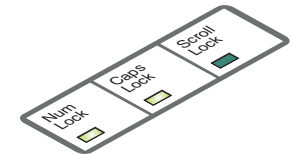

- 4 Press **F1** to confirm your option.

The three keyboard indicators ('Num Lock', 'Caps Lock' and 'Scroll Lock') will now begin to flash in sequence again.

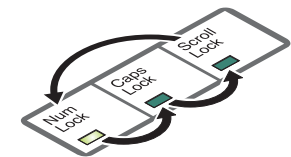

To exit from configuration mode:

- 1 Within configuration mode, the three keyboard indicators should be flashing in sequence to show that the module is ready to receive a new command.

- 2 Press **F1**.

The three indicators will return to their normal states.

Password setting

Password protection allows you restrict access to the system only to authorised personnel. A password first needs to be set and then, using the keyboard attached to the REMOTE module, a simple key sequence allows the system to be quickly and securely detached from its peripherals.

To set a password

- 1 Simultaneously, press the hotkeys (by default, **Ctrl** and **Shift**) along with **⏏** to enter configuration mode.
- 2 Press **P** followed by **⏏**.
- 3 Now enter your new password, within the following constraints:
 - Passwords are NOT case sensitive,
 - Passwords may be any length from 1 character to a maximum of forty characters,
 - The following keys may NOT be used: **Ctrl**, **Alt**, **Shift** or **⏏**
- 4 When you have entered the password, press **⏏** to signal its completion.
- 5 Press **⏏** once more to exit configuration mode.

For full details about how to lock and unlock the system using your password, please see the 'Locking and unlocking the system' section in the 'Installation and operation' chapter.

Password override

This mode allows you to override the password that has been set at the REMOTE module and place it into configuration mode so that a new one may be set. This feature is particularly useful when passwords have been lost or forgotten.

To override the REMOTE password

- 1 Remove power from the REMOTE module.
- 2 With power to the system and LOCAL module still applied, change LOCAL switch 1 to the ON position.
- 3 Re-apply power to the REMOTE module. The REMOTE module will go directly into configuration mode so that the old password can be cleared and a new one set.
 - **To clear a password:** (within configuration mode) Press **P** followed by **⏏** and followed by **⏏** again.
 - You can now enter a new password using the procedure outlined in steps 2 to 5 of the 'Password setting' section, or press **⏏** to exit configuration mode.
- 4 Return LOCAL switch 1 to its OFF position.

Note: If switch 1 remains ON, then the REMOTE module will enter configuration mode whenever it is repowered and will not operate normally.

Hot plugging and mouse restoration

It is strongly recommended that you switch off the computer system before attempting to connect it via the Gold Extender modules. However, if this is not possible then you need to 'hot plug' the Gold Extender modules while power is still applied to the system. There is not normally a danger of damage to the system, however, when mouse communications are interrupted, often they fail to reinitialise when reconnected. Gold Extender modules provide a feature to reinstate mouse communications once the necessary connections have been made.

There are two main types of data formats used by current PC mice, these are the older 'PS/2' format and the more recent 'IntelliMouse®' format introduced by Microsoft. These use slightly different data arrangements and it is important to know which type was being used before you hot-plugged the Gold Extender modules. The previous setting depends both on the type of mouse and the type of driver as various combinations of PS/2 and Intellimouse are possible. Using the incorrect restore function may produce unpredictable results and require the system to be rebooted.

Which restore setting do I use?

The general rule is that unless both the mouse *and* the driver are *both* Intellimouse compatible then you need to restore the mouse as 'PS/2'.

Recognising an Intellimouse-style mouse

The Intellimouse format was introduced to support, among other features, the scroll wheel function. If your mouse has a scroll wheel, then it is likely to support the Intellimouse format. If you have a Microsoft mouse, then it will usually state that it is an Intellimouse on its underside label.

Recognising an Intellimouse driver

Before hot plugging your Gold Extender (or afterwards using only keyboard control), access the Windows Control Panel and select either the *Mouse* option (on Windows NT, 2000 and XP) or the *System* option (on Windows 95, 98, ME). Look for the name of the driver, which will usually include the words *PS/2* or *Intellimouse*.

To restore mouse operation when hot plugging:

- 1 Carefully connect the Gold Extender modules to the system and its keyboard, mouse, monitor, audio and serial device.
- 2 Simultaneously, press the hotkeys (by default, **Ctrl** and **Shift**) along with **F1** to enter configuration mode.
- 3 Enter the appropriate restore function code:
 - *PS/2* – press **M 6** **F1**
 - *IntelliMouse* – press **M 7** **F1**
- 4 To exit configuration mode, press **F1**.
- 5 Move the mouse a short distance and check for appropriate on-screen cursor movement. If the mouse cursor darts erratically around the screen, then cease moving the mouse. This is an indication that the chosen restore function is incorrect. Try again using the other restore function.

Note: The restore functions predict the likely mouse resolution settings but may not restore the exact speed or sensitivity settings that were originally set.

Microsoft and Logitech -specific mouse settings

In certain installations some Logitech mouse drivers may lose the action of the mouse buttons when used with the standard 'Microsoft compatible' signalling protocol used between the modules. To solve this problem, select the 'Logitech compatible' mouse signalling protocol.

To change mouse signalling protocols

- 1 Simultaneously, press the hotkeys (by default, **Ctrl** and **Shift**) along with **F1** to enter configuration mode.
- 2 Enter the appropriate protocol code:
 - *Microsoft compatible* – press **M 3** **F1**
 - *Logitech compatible* – press **M 4** **F1**
- 3 To exit configuration mode, press **F1**.

Video compensation

The Gold Extender incorporates video compensation circuitry to maximise the picture quality for any given length of twisted pair cable. The amount of video compensation required increases proportionally with the length of cable run that is being used.

The Gold Extender can automatically correct the video compensation settings for any length of cable, however in certain circumstances you may wish to finely adjust and fix the compensation level to suit personal preferences - this can be done by switching to manual compensation mode.

To display a suitable high contrast image

The best way to clearly view the effects of compensation is to display a high contrast image, with vertical edges, on the screen.

- Open a word processor, type the capital letter 'H', or 'M' and increase the point size to 72 or higher. For best results, the background should be white and the character should be black.
- A BLACK shadow on the right of the character indicates UNDER compensation.
- A WHITE shadow on the right of the character indicates OVER compensation.

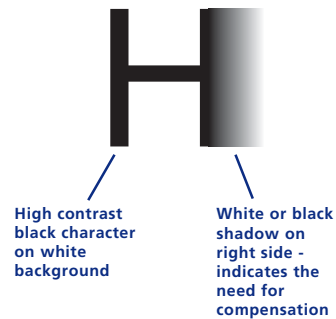

To manually adjust the video compensation

- 1 Change REMOTE switch 4 to the ON position.
- 2 Press, in unison, the hotkeys (by default, **Ctrl** and **Shift**) along with **↓** to enter configuration mode.

The three keyboard indicators ('Num Lock', 'Caps Lock' and 'Scroll Lock') will now begin to flash in sequence. The speed of the sequence indicates the level of compensation currently applied: the slower the rate, the less compensation is being applied.

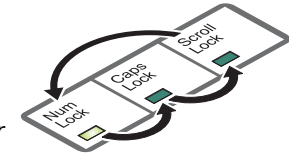

- 3 While watching the displayed high contrast screen image, now adjust the video compensation setting using the following keys:
 - Optionally press **F 2** **↓** to make the circuitry calculate and apply an automatic compensation level - you can use this as a starting point for your fine tuning.
 - Press **↑** to increase compensation by one fine step,
 - Press **Page Up** to increase compensation by one coarse step,
 - Press **Home** to select the neutral setting (no compensation),
 - Press **Page Down** to decrease compensation by one coarse step,
 - Press **↓** to decrease compensation by one fine step.

Note: In total there are twenty two fine steps from one end of the scale to the other. One coarse step jumps roughly five fine steps.

*Note: If the monitor goes blank and switches off (due to extreme over compensation) press the **Esc** key to restore it.*

- 4 When no shadows are visible and the displayed images have crisp edges, press **↓** to exit configuration mode.

The new compensation setting will be stored, even when power is removed or if a complete reset is initiated. The setting should not require further changes, unless the cabling arrangement is altered.

Note: If REMOTE switch 4 is returned to its OFF position, the video compensation level will be recalculated and set at the next power on.

If video compensation cannot solve the problem

If automatic and manual compensation is unable to solve the problem, an additional module called a 'Skew Compensator' may be required. Please see the next section for details.

The Skew Compensator

The twisted pair cabling supported by the Gold Extender set (category 5, or higher) consists of four pairs of cables. Three of these pairs are used by the modules to convey red, green and blue video signals to the remote video monitor. Due to the slight difference in twist rate between these three pairs, the red, green and blue video signals may not arrive at the monitor together. This is visible as separate colour shadows on high contrast screen images. This effect is particularly apparent when using higher screen resolutions and some types of category 5e cables.

In this situation, Adder recommend the use of an optional module called the 'Skew Compensator' (part code: X-SC). This manually adjustable, passive device can apply fine timing changes to the video signals ensuring they arrive together thus removing the colour separation. The REMOTE module includes a skew report function that indicates how to set the multiple switches on the Skew Compensator. This report function can also be a useful tool in determining if a skew compensator is required.

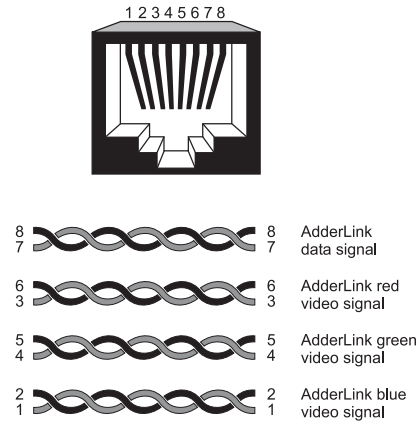

To produce a skew compensator report

- 1 Ensure that the video image is correctly compensated using the procedure outlined in the previous section (the report will be more accurate if internal compensation is correctly applied).
- 2 Open an application that can display typed keys as screen characters - e.g. a word processor or Windows Notepad. The skew report will be written to the application by generating a series of 'faked' keypresses.
- 3 Press, in unison, the hotkeys (by default, **Ctrl** and **Shift**) along with **F1** to enter configuration mode.
- 4 Enter one of the following codes, depending on the type of keyboard being used:
 - QWERTY keyboard (i.e. English, German), press **F1** **3**
 - AZERTY keyboard (French), press **F1** **4**

The screen will go blank for a few seconds whilst the measurements are made. When the picture is restored, a report, similar to that shown above right will be generated.

SKEW REPORT

RED +0.5M
GREEN +1.0M
BLUE +0.0M

SWITCHES ON
A3 B4

Indicates the differences in length between the three cable pairs. In this case the Blue pair is the shortest and the Green pair is 1 metre longer

Indicates the Skew Compensator switches that would need to be set in order to correct the current cable-length mismatch

- 5 Press **F1** to exit configuration mode. Communicate the report findings to Adder technical support for full advice on whether a Skew Compensator is required.

Miscellaneous settings

The following are configuration settings within the modules that are not covered in other sections of this guide. These can be achieved once within configuration mode by pressing the indicated keys:

Report Gold Extender firmware version - **F1** **1** **F1**

Before initiating this command, ensure that the system is running an application that can display typed keys as screen characters - e.g. a word processor or Windows Notepad. The current firmware version will be written to the application in the form of the letter 'V' followed by three numbers - for example V118 means version 1.18.

Reset all configuration options to default states - **F8** **F1**

Returns all user configurable options to the settings that are installed at manufacture. The password will be cleared, however, the current video compensation setting will not be reset.

Flash upgrade

As part of the continual development and improvement process across the range of Adder products, software upgrades are occasionally made available. The LOCAL and REMOTE modules both contain internal flash memory and Adder's unique keyboard-link upgrade technique allow you to utilise software upgrades in a straightforward manner.

Note: It is important to upgrade both the LOCAL and REMOTE modules together so that they are both running the same new version of software.

Note: To upgrade the REMOTE module, a special keyboard connection cable is required. This cable must have 6pin mini-DIN male to 6pin mini-DIN male plugs with all lines connected - this is a common cable used with KVM switches.

To perform a flash memory upgrade, you need to perform the following stages:

- **Stage A** – Download upgrade files from the Adder website
- **Stage B** – Create a startup diskette and copy the files to it
- **Stage C** – Reconfigure the LOCAL module connections and begin
- **Stage D** - Reconfigure the REMOTE module connections and begin
- **Stage E** - Return all connections to their usual states

Stage A - Download the upgrade files

To download the files

- 1 Access the Adder Technology Ltd website (www.adder.com), enter the Support section. Choose the upgrade option that best suits your requirements and download it to your system.
- 2 Decompress the downloaded file. Depending on the chosen option, there will be a collection of suitable files. As a minimum, there should be the following files:
 - AUTOEXEC.BAT – directs the computer to run the upgrade programs.
 - XKVMxxx.EXE – this is the upgrade program that automatically determines which module is connected and sends the appropriate firmware file.
 - XGLOCxxx.HEX – this is the firmware file for the LOCAL module.
 - XGREMxxx.HEX – this is the firmware file for the REMOTE module.*Where xxx is the upgrade version number.*

Now please follow Stage B.

Stage B - Create a startup diskette

For this stage you will need a 3½ floppy diskette that is either blank or has existing contents that are no longer required. The write protect tab must be moved to the 'unprotected' position. Depending on your operating system, use one of the following to create a startup disk:

To create a startup disk in Windows XP

- 1 Insert a diskette into the floppy disk drive.
- 2 Select 'Start' and then 'My Computer'.
- 3 Right mouse click on the '3½ Floppy (A:)' icon and select 'Format'.
- 4 Check the 'Create an MS-DOS startup disk' box and select 'Start'.

To create a startup disk in Windows 95/98/Me

- 1 Insert a formatted diskette into the floppy disk drive.
- 2 Select 'Start', then 'Settings' and then 'Control Panel'.
- 3 Double click on the 'Add/Remove Programs' icon.
- 4 Select the 'Startup Disk' tab.
- 5 Click 'Create Disk' and follow the instructions.

To create a startup disk in Windows 95/98 (alternative method)

- 1 Insert a diskette into the floppy disk drive.
- 2 Right mouse click on the '3½ Floppy (A:)' icon and select 'Format'.
- 3 Select the 'Full format' option and ensure that the 'Copy system files' box is checked.
- 4 Select 'Start' to format the disk.

To create a startup disk from MS-DOS or a DOS window within Windows 95/98

- 1 Insert a diskette into the floppy disk drive and check that the drive is configured as drive A (it usually is).
- 2 At the DOS prompt (C:\>) type:

```
FORMAT A: /S
```

and follow the instructions given by DOS.

Copy the downloaded files to the disk

Once the diskette has been formatted, using Windows Explorer or the My Computer option, copy the downloaded and decompressed files from your computer to the floppy diskette.

Now please follow Stage C.

Stage C - Reconfigure the LOCAL connections and begin

- 1 On the computer from which you will run the upgrade, ensure that its BIOS settings will allow it to boot from the floppy diskette drive, rather than booting immediately from the hard drive.
- 2 Switch off the computer and disconnect the twisted pair cable from the LOCAL module.
- 3 On the KVM+A multi-cable, leave the keyboard connector attached to the keyboard port of the computer. Disconnect the KVM+A multi-cable video and mouse connectors from the ports on the computer.
- 4 So that you can check upgrade progress, connect a monitor directly to the video port of the computer.
- 5 On the LOCAL module, change switch 1 to the ON position. Ensure that the upgrade diskette is in the floppy disk drive of the computer.
- 6 Switch on the computer. The upgrade process will start automatically and confirmation will be given on screen.
- 7 Switch off the computer and disconnect the KVM+A multi-cable. Leave the monitor connected and the upgrade diskette in the floppy disk drive. Return LOCAL switch 1 to the OFF position.

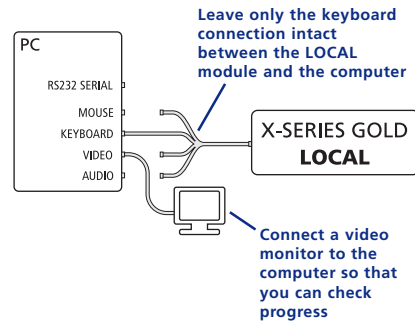

Now please follow Stage D.

Stage D - Reconfigure the REMOTE connections and begin

- 1 Disconnect all cables from the REMOTE module and take it to the computer.
- 2 Use a 'KVM switch-type' keyboard cable (6pin mini-DIN male to 6pin mini-DIN male plugs with all lines connected) - not supplied. Attach one end of the cable to the keyboard port of the computer. Connect the other end of the cable to the keyboard port of the REMOTE module. This is the only connection required.
- 3 On the REMOTE module, change switch 1 to the ON position.
- 4 Attach the power supply unit to the POWER input of the REMOTE module and connect the mains lead to a nearby wall socket.
- 5 Switch on the computer. The upgrade process will start automatically and confirmation will be given on screen.
- 6 Switch off the computer and disconnect the REMOTE module. Return REMOTE switch 1 to the OFF position.

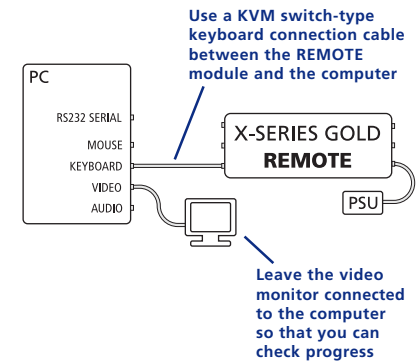

Now please follow Stage E.

Stage E - Return all connections to their usual states

Once the upgrade process has been completed, perform the following to return the system to its previous state.

- 1 Ensure that switch 1 on both the LOCAL and REMOTE modules are set to their OFF positions.
- 2 Refer to the 'Installation and operation' chapter for detailed instructions on correctly connecting the LOCAL and REMOTE modules to the computer, its peripherals, the REMOTE power supply and the twisted pair cable.
- 3 Remove the diskette from the system and reboot. The upgrade process is now complete.

Further information



Troubleshooting

If you experience problems when installing or using the Gold Extender modules, please check through this section for a possible solution. If your problem is not listed here and you cannot resolve the issue, then please refer to the 'Getting assistance' section.

Video image at the REMOTE module is distorted or shadows appear to the right of displayed objects.

Video compensation is required to compensate for the length of the twisted pair cable being used. If video problems persist:

- Please refer to the 'Video compensation' section in the 'Special Configuration' chapter.
- If the overall video image is 'fuzzy' and/or has coloured shadows you may need to use the optional X-Series Skew Compensator. This stand-alone passive module allows you to finely tune the red, green and blue video signal timings (each of which is fed along separate twisted pairs) to overcome most colour separation problems. Please refer to the 'Skew Compensator' section in the 'Special Configuration' chapter.

No video image is received at the REMOTE module.

- Check that the power/activity indicators are lit on the LOCAL and REMOTE modules - if they are not, then there is a power problem. When keys are pressed or the mouse is moved, check that the indicators flicker – if they do not then there could be a twisted pair link problem or a problem with one of the modules.
- Check that the Category 5 (or higher) cable is wired correctly as per the diagram in the 'Skew Compensator' section in the 'Special Configuration' chapter.
- If possible, try using an alternative twisted pair connection between the modules.
- If the REMOTE module is severely over compensated, the monitor may not be able to display a picture. Try manually reducing the video compensation. Please refer to the 'Video compensation' section in the 'Special Configuration' chapter.
- Temporarily disconnect the video link to the LOCAL module, connect a monitor directly to the computer video port and check for a correct video image output.

Power is applied via the power supply but REMOTE module operation has stopped.

- Each module has an internal automatic cut-out fuse to protect against power surges. To reset, remove power from the module for one second and then reconnect.

The on-screen mouse pointer does not respond to mouse movements

- The mouse connection may have been interrupted. Either, reboot the system and re-power the REMOTE module power supply, or try using the mouse restoration command. Please refer to the 'Hot plugging and mouse restoration' section in the 'Special Configuration' chapter.

Sound from the microphone cannot be heard or is very quiet

- Check the setting of LOCAL switch 3 - if a microphone is connected at the REMOTE module, the switch should be set OFF.

Sound input from the stereo line input is distorted ('tinny' sounding) and only one channel is working

- Check the setting of LOCAL switch 3 - if a stereo line input is connected at the REMOTE module, the switch should be set ON.

Getting assistance

If you are still experiencing problems after checking the list of solutions in the Troubleshooting section then we provide a number of other solutions:

- **Adder Technology website – www.adder.com**
Check the Support section of our website for the latest solutions and driver files.
- **Email – support@adder.com**
- **Fax** in the UK: **01954 780081**
 in the US: **+1 888 275 1117**
- **Phone** in the UK: **01954 780044**
 in the US: **+1 888 275 3337**

Other products in the X-Series range

The following related X-Series items are available:

- **Dual video transmitter (part code: X-DVT)**
Allows one system to be controlled from two locations or permits a second video channel to be sent to a remote location. Used in conjunction with two standard receiver/remote modules.
- **Skew compensator (part code: X-SC)**
Removes colour split in video signals caused by certain Cat 5e and 6 cables. Required only in certain installations with long cable lengths and high video resolutions.
- **Rack mount chassis (part code: RMK-CHASSIS)**
This 19" chassis allows multiple X-Series modules to be neatly arranged within a standard cabinet. Securing plates and screws are supplied separately for each X-Series module for use with the rack mount chassis.
- **Power distribution module (part code: X-PDM4)**
Provides power for up to four X-Series modules to reduce mains power socket requirements.
- **Rack mount securing plates**
 - for Gold Extender remote module (part code: X-RMK-KVMAS/R)
 - for Gold Extender local module (part code: X-RMK-KVMAS/T)
 - for Dual Video Transmitter (part code: X-RMK-DVT)
 - for Skew compensator (part code: X-RMK-SC)
 - single slot blanking plate (part code: X-RMK-BLANK)
 - quad slot blanking plate (part code: X-RMK-BLANK4)

Safety information

- For use in dry, oil free indoor environments only.
- Warning - live parts contained within power adapter.
- No user serviceable parts within power adapter - do not dismantle.
- Plug the power adapter into a socket outlet close to the module that it is powering.
- Replace the power adapter with a manufacturer approved type only.
- Do not use the power adapter if the power adapter case becomes damaged, cracked or broken or if you suspect that it is not operating properly.
- If you use a power extension cord with the module, make sure the total ampere rating of the devices plugged into the extension cord does not exceed the cord's ampere rating. Also, make sure that the total ampere rating of all the devices plugged into the wall outlet does not exceed the wall outlet's ampere rating.
- Do not attempt to service the modules yourself.

Warranty

Adder Technology Ltd warrants that this product shall be free from defects in workmanship and materials for a period of two years from the date of original purchase. If the product should fail to operate correctly in normal use during the warranty period, Adder will replace or repair it free of charge. No liability can be accepted for damage due to misuse or circumstances outside Adder's control. Also Adder will not be responsible for any loss, damage or injury arising directly or indirectly from the use of this product. Adder's total liability under the terms of this warranty shall in all circumstances be limited to the replacement value of this product.

If any difficulty is experienced in the installation or use of this product that you are unable to resolve, please contact your supplier.

Radio Frequency Energy

A Category 5 (or better) twisted pair cable must be used to connect the AdderLink units in order to maintain compliance with radio frequency energy emission regulations and ensure a suitably high level of immunity to electromagnetic disturbances.

All other interface cables used with this equipment must be shielded in order to maintain compliance with radio frequency energy emission regulations and ensure a suitably high level of immunity to electromagnetic disturbances.

European EMC directive 89/336/EEC



This equipment has been tested and found to comply with the limits for a class A computing device in accordance with the specifications in the European standard EN55022. These limits are designed to provide reasonable protection against

harmful interference. This equipment generates, uses and can radiate radio frequency energy and if not installed and used in accordance with the instructions may cause harmful interference to radio or television reception. However, there is no guarantee that harmful interference will not occur in a particular installation. If this equipment does cause interference to radio or television reception, which can be determined by turning the equipment on and off, the user is encouraged to correct the interference with one or more of the following measures: (a) Reorient or relocate the receiving antenna. (b) Increase the separation between the equipment and the receiver. (c) Connect the equipment to an outlet on a circuit different from that to which the receiver is connected. (d) Consult the supplier or an experienced radio/TV technician for help.

FCC Compliance Statement (United States)

This equipment generates, uses and can radiate radio frequency energy and if not installed and used properly, that is, in strict accordance with the manufacturer's instructions, may cause interference to radio communication. It has been tested and found to comply with the limits for a class A computing device in accordance with the specifications in Subpart J of part 15 of FCC rules, which are designed to provide reasonable protection against such interference when the equipment is operated in a commercial environment. Operation of this equipment in a residential area may cause interference, in which case the user at his own expense will be required to take whatever measures may be necessary to correct the interference. Changes or modifications not expressly approved by the manufacturer could void the user's authority to operate the equipment.

Canadian Department of Communications RFI statement

This equipment does not exceed the class A limits for radio noise emissions from digital apparatus set out in the radio interference regulations of the Canadian Department of Communications.

Le présent appareil numérique n'émet pas de bruits radioélectriques dépassant les limites applicables aux appareils numériques de la classe A prescrites dans le règlement sur le brouillage radioélectriques publié par le ministère des Communications du Canada.



© 2003 Adder Technology Limited
All trademarks are acknowledged.
Release 1.0b
July 2003
Part No. ADD0049/1

Adder Technology Limited,
Technology House,
Trafalgar Way,
Cambridge, CB3 8SQ,
United Kingdom
Tel: +44 (0)1954 780044
Fax: +44 (0)1954 780081

Adder Corporation,
29 Water Street,
Newburyport,
MA 01950,
United States of America
Tel: +1-888-932-3337
Fax: +1-888-275-1117

CONTENTS

WELCOME

INSTALLATION
& OPERATION

SPECIAL
CONFIGURATION

FURTHER
INFORMATION