

# Andon SmartBOX for Signal Towers



Andon SmartBOX for use in industrial applications

## **i** TECHNICAL SPECIFICATIONS/ORDER SPECIFICATIONS:

<b>Dimensions (B x H x T):</b>	161 mm x 79 mm x 138 mm
<b>Housing:</b>	PA-GF Switches: PC
<b>Fixing:</b>	Base mounting, Wall mounting
<b>Connection:</b>	Via 5 m cable
<b>Number of signal elements:</b>	Max. 4 additional signal elements possible
<b>Assembly:</b>	Andon SmartBOX, power supply unit with connection cable (length 1.8 m), USB power supply, Adapter supplied (EU, UK, North America)
<b>Voltage power supply unit:</b>	100-240 V AC
<b>Voltage signal elements:</b>	24 V DC
<b>Current consumption:</b>	Max. 1 A
<b>Order no.:</b>	<b>860 000 09</b>

## TECHNICAL DIAGRAMS:

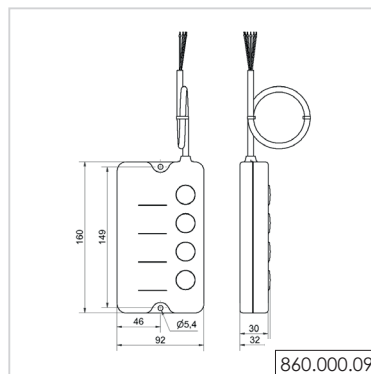

Interchangeable adaptors (included in assembly) and wide input voltage range make the Power Supply suitable for worldwide use





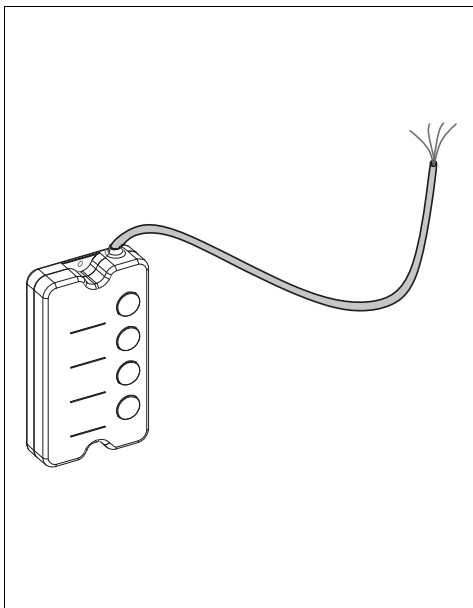
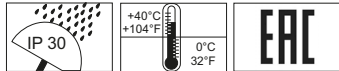





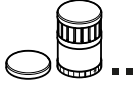
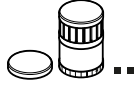
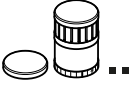





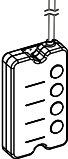

EN 60950-1

 **DANGER**

- (D) Anschluss **ausschließlich** durch ausgebildete Elektro-Fachkräfte. Betrieb **ausschließlich** mit dem im Lieferumfang enthaltenen Netzteil zulässig.
- (GB) Electrical connection is to be made by trained electrical specialists **only**. Operation **only** with power adapter included in assembly.
- (F) Le branchement doit **uniquement** être effectué par des professionnels. Opération **seulement** permise avec le bloc d'alimentation compris dans la livraison et câble.
- (I) Il collegamento deve essere eseguito **solo** da elettricisti specializzati. Questo prodotto deve essere utilizzato **solo** con l'allegato alimentatore e con il cavo.
- (E) La conexión **sólo** debe ser realizada por electricistas debidamente formados. Este producto se debe utilizar solamente con la fuente de alimentación (incluido en el volumen entregado).
- (PT) A ligação deve ser feita **exclusivamente** por profissional elétrico especializado. Operação apenas com adaptador de corrente incluído na embalagem.
- (NL) De aansluiting mag **enkel** gebeuren door erkende vakmensen. Werkt **enkel** met stroom adapter (inclusief in de assemblage).
- (CZ) Připojení smí provádět pouze kvalifikovaný personál. Funkční pouze s originálním napájecím adaptérem.
- (PL) Podłączenie wyłącznie przez specjalistów-elektryków. Praca tylko i wyłącznie z zasilaczem znajdującym się w zestawie.
- (FI) Liittäminen kuuluu ainoastaan koulutettujen sähköalan ammattilaisten tehtäviin. Käyttö vain toimitukseen sisältyvällä verkkolaitteella.
- (RUS) Подключение проводится только специалистом-электриком. Эксплуатация допускается только с входящими в комплект поставки блоком.
- (TR) Bağlantı sadece eğitimli elektrik teknisyenleri tarafından yapılmalıdır. Sadece montaj dahilinde verilen güç adaptörü.
- (CN) 布线需由专业电工执行。只能用自带适配器工作。



	KombiSIGN 40	KombiSIGN 70	KombiSIGN 71	KombiSIGN 72
<b>Acoustic/ Cap/ Light (max. 4)</b>	634/ 635 	840/842, 843/844 	641/643, 644/645 	645/ 647 
<b>Slave/ Transmitter/ Master/ Receiver</b>		860/861 	860/861 	860/861 
<b>Terminal element</b>	630 	840 	640 	640 
<b>Output</b>				
Output: 24 V=, I <sub>max</sub> 1 A				
<b>Andon SmartBOX</b>	860.000.09 	860.000.09 	860.000.09 	860.000.09 
<b>Input</b>				
 <b>DANGER</b>				
		Input: 115-230 V~, 50-60 Hz		

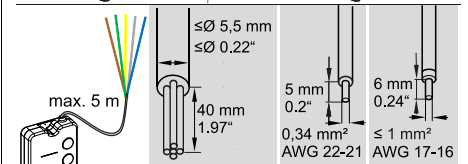
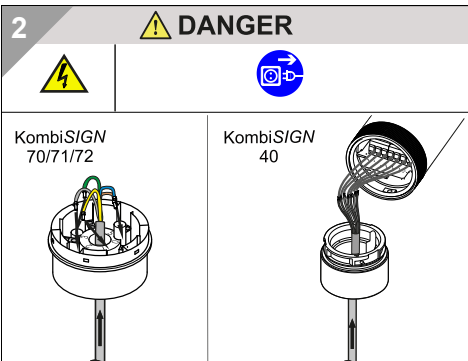
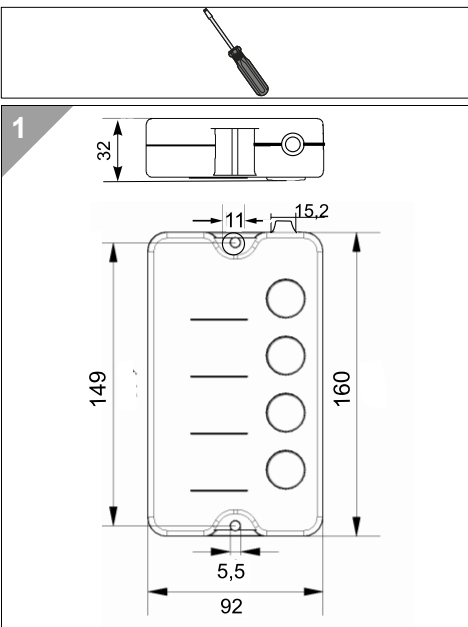

Anschlussklemme Pin	Litzenfarbe Wire colour
1	weiß, white
2	braun, brown
3	grün, green
4	gelb, yellow
5 - 24 V	grau, grey
-	-
0 - GND	blau, blue
-	-

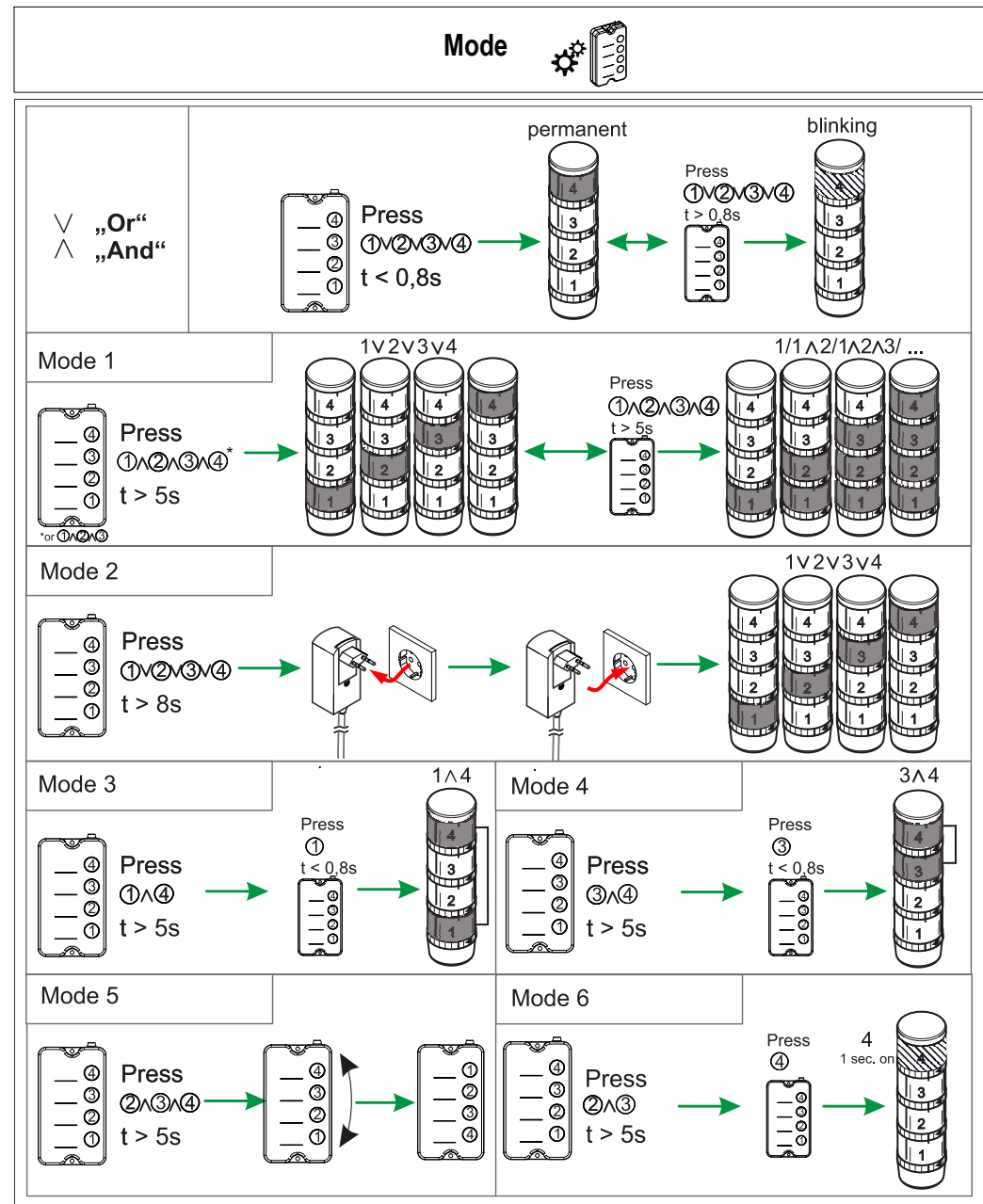
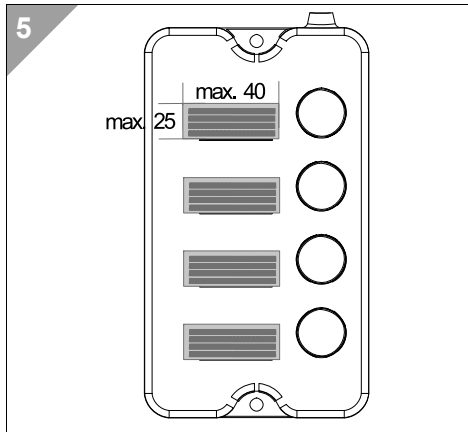
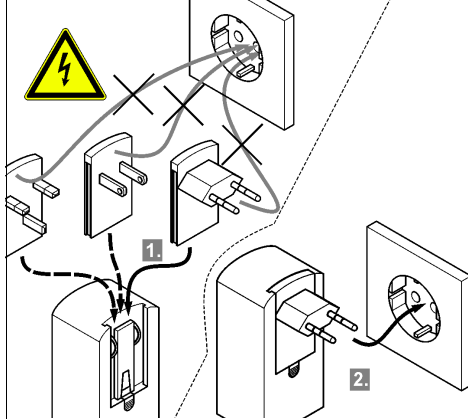
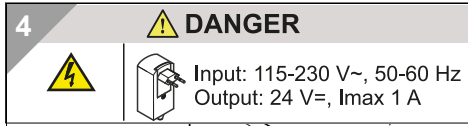
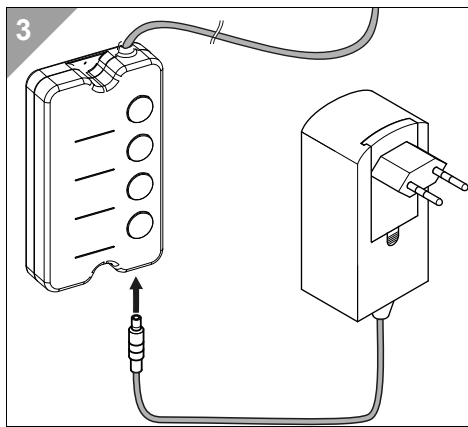

310.860.020.1116\_AB

© D