

S2D200-BH18-01

AC axial fan

sickled blades (S series)
with guard grille for full nozzle

ebm-papst Mulfingen GmbH & Co. KG

Bachmühle 2 · D-74673 Mulfingen

Phone +49 7938 81-0

Fax +49 7938 81-110

info1@de.ebmpapst.com

www.ebmpapst.com

Limited partnership · Headquarters Mulfingen
County court Stuttgart · HRA 590344

General partner Elektrobau Mulfingen GmbH · Headquarters Mulfingen
County court Stuttgart · HRB 590142

Nominal data

Type	S2D200-BH18-01		
Motor	M2D068-BC		
Phase		3~	3~
Nominal voltage	VAC	400	400
Connection		Y	Y
Frequency	Hz	50	60
Type of data definition		fa	fa
Valid for approval / standard		CE	CE
Speed	min ⁻¹	2600	2900
Power input	W	68	70
Current draw	A	0.17	0.13
Max. back pressure	Pa	140	140
Max. ambient temperature	°C	45	70
Starting current	A	0.36	0.32

ml = max. load · me = max. efficiency · fa = running at free air · cs = customer specs · cu = customer unit
Subject to alterations



AC axial fan

sickled blades (S series)
with guard grille for full nozzle

Technical features

Mass	1.6 kg
Size	200 mm
Surface of rotor	Coated in black
Material of blades	Sheet steel, coated in black
Material of guard grille	Steel, phosphated and coated in black plastic
Number of blades	9
Direction of air flow	"V"
Direction of rotation	Counter-clockwise, seen on rotor
Type of protection	IP 44
Insulation class	"B"
Humidity class	F1-2
Max. permissible ambient motor temp. (transp./ storage)	+ 80 °C
Min. permissible ambient motor temp. (transp./storage)	- 40 °C
Mounting position	Shaft horizontal or rotor on bottom; rotor on top on request
Condensate discharge holes	Rotor-side
Operation mode	S1
Motor bearing	Ball bearing
Touch current acc. IEC 60990 (measuring network Fig. 4, TN system)	< 0.75 mA
Cable exit	Lateral
Protection class	I (if protective earth is connected by customer)
Product conforming to standard	EN 60335-1
Approval	CCC; GOST



AC axial fan

sickled blades (S series)

with guard grille for full nozzle

Product drawing

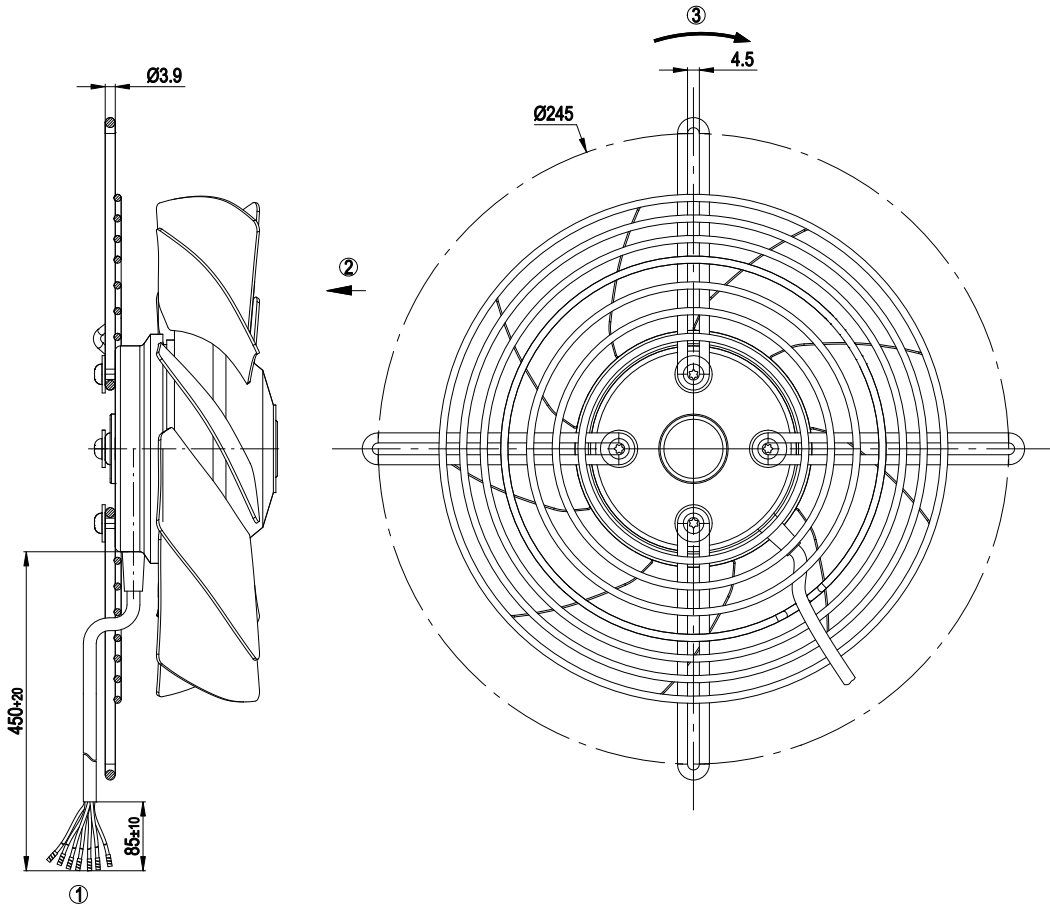

- | | |
|---|---|
| 1 | Connection line PVC, 7x crimped core-end sleeves |
| 2 | Direction of air flow "V" |
| 3 | Direction of rotation counterclockwise, seen on rotor |



AC axial fan

sickled blades (S series)

with guard grille for full nozzle

Connection screen

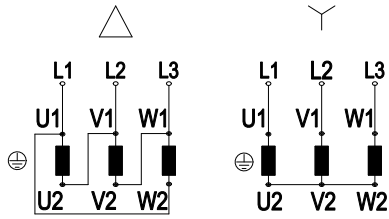

Note: Direction of rotation changes when two phases are reversed

Δ	Delta connection	Y	Star connection	L1	black
L2	blue	L3	brown	U1	black
V1	blue	W1	brown	U2	green
V2	white	W2	yellow		



AC axial fan

sickled blades (S series)
with guard grille for full nozzle

Charts: Air flow 50 Hz

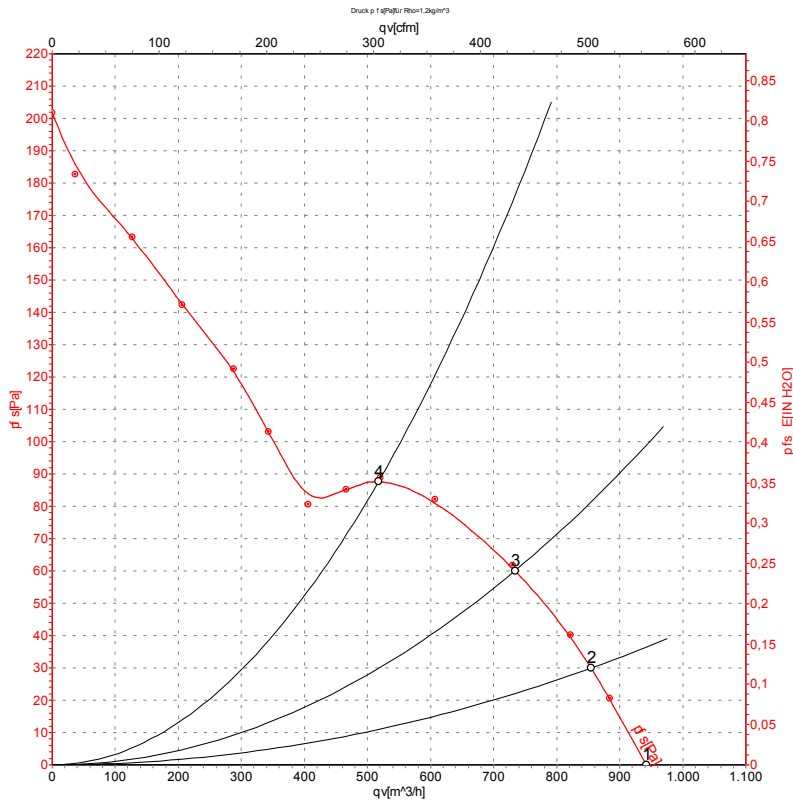

Measurement: LU-26980

Air performance measured as per ISO 5801 Installation category A. For detailed information on the measuring set-up, please contact ebm-papst. Suction-side noise levels: LwA measured as per ISO 13347 / LpA measured with 1m distance to fan axis. The values given are valid under the measuring conditions mentioned above and may vary according to the actual installation situation. With any deviation from the standard set-up, the specific values have to be checked and reviewed with the unit installed.

Measured values

	U	f	n	Pe	I	qv	pfs
	V	Hz	min ⁻¹	W	A	m ³ /h	Pa
1	400	50	2600	68	0.17	940	0
2	400	50	2550	69	0.17	855	30
3	400	50	2500	72	0.17	735	61
4	400	50	2460	75	0.17	515	89

U = Supply voltage · f = Frequency · n = Speed · Pe = Power input · I = Current draw · qv = Air flow · pfs = Pressure increase



AC axial fan

sickled blades (S series)

with guard grille for full nozzle

Charts: Air flow 60 Hz

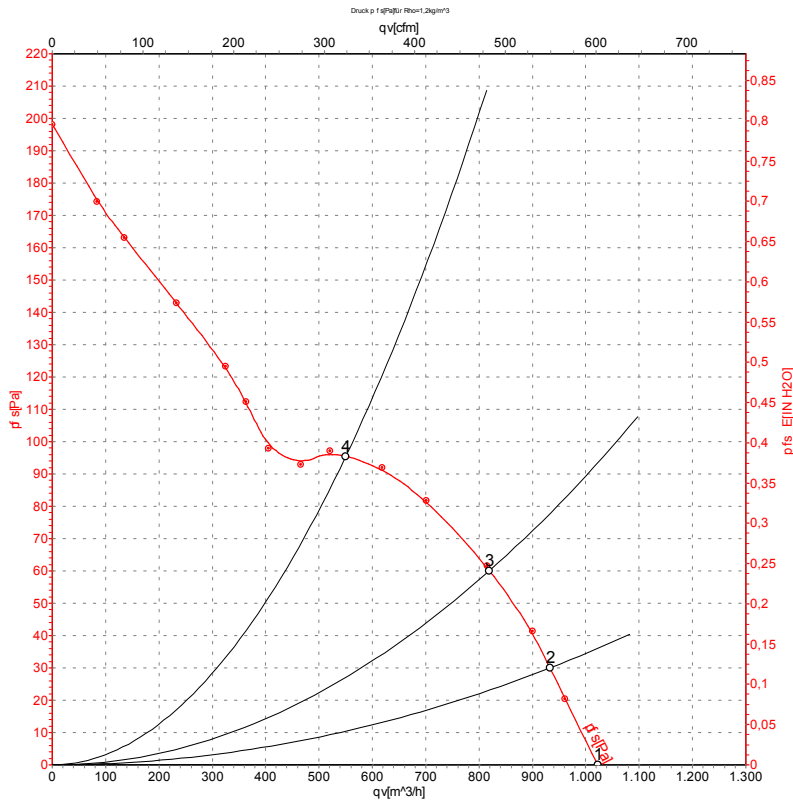

Measurement: LU-26981

Air performance measured as per ISO 5801 Installation category A. For detailed information on the measuring set-up, please contact ebm-papst. Suction-side noise levels: L_{wA} measured as per ISO 13347 / L_{pA} measured with 1m distance to fan axis. The values given are valid under the measuring conditions mentioned above and may vary according to the actual installation situation. With any deviation from the standard set-up, the specific values have to be checked and reviewed with the unit installed.

Measured values

	U	f	n	P _e	I	qv	P _{fs}
	V	Hz	min ⁻¹	W	A	m ³ /h	Pa
1	400	60	2815	70	0.13	1020	0
2	400	60	2745	73	0.14	935	30
3	400	60	2670	77	0.14	820	61
4	400	60	2595	81	0.15	550	96

U = Supply voltage · f = Frequency · n = Speed · P_e = Power input · I = Current draw · qv = Air flow · P_{fs} = Pressure increase

