

# Modular F.R.L. Unit



Integrated digital pressure switch type is now available.



**Series AC**



# Modular F.R.L. Unit Series AC

## Space-saving design

The use of a compact spacer with bracket reduces the total assembly space.

Model		Reduction (mm)
New	Old	
AC10	AC1000	4
AC20	AC2000	14
AC25	AC2500	14
AC30	AC3000	14
AC40	AC4000	18
AC40-06	AC4000-06	18
AC50	AC5000	18
AC55	AC5500	18
AC60	AC6000	18

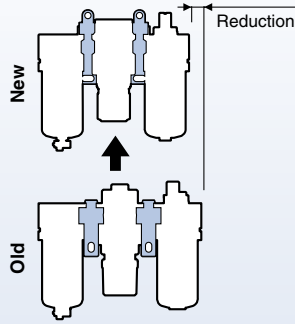

Improved visibility for lubricant drip with graduation for lubricant control

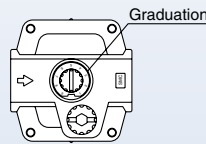

## Improved installation

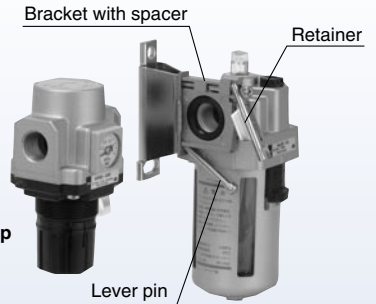

- ① Attach the component into the fitting of the spacer with bracket.
- ② Lock the lever pin into the retainer. (temporary installation)

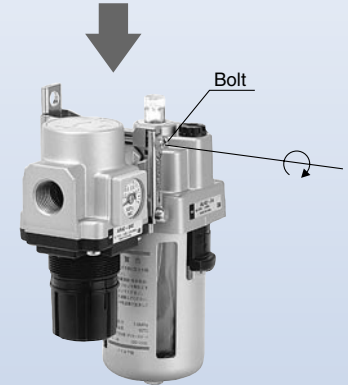

- ③ Tighten the bolt.

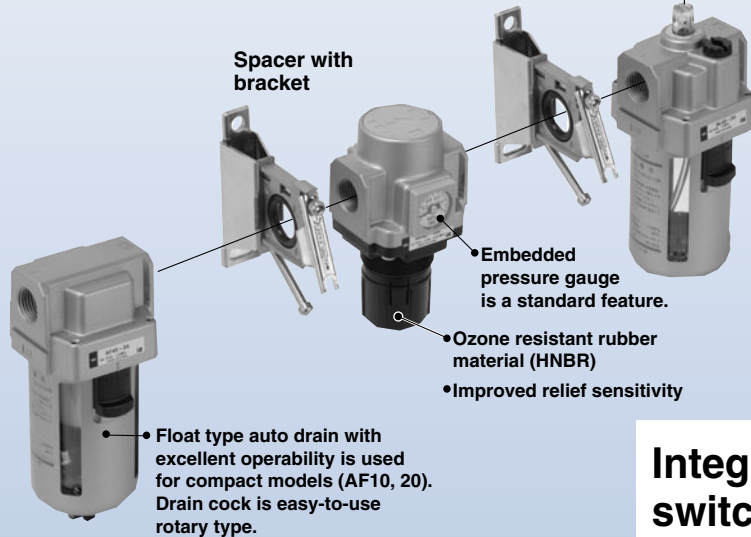

## Knob cover

Prevents careless adjustment of the pressure setting.



Part no.	Model
AR20P-580AS	AC20□/AR20/AR20K/AW20, AW20K/AWM20/AWD20
AR25P-580AS	AC25□/AR25/AR25K
AR30P-580AS	AC30□/AR30/AR30K/AW30, AW30K/AWM30/AWD30
AR40P-580AS	AC40□(-06)/AR40(-06)/AR40K(-06)/AW40(-06)/AW40K(-06)/AWM40/AWD40

## Integrated digital pressure switch type is now available. New



- Filter Regulator AW20(K) to 60(K)
- Mist Separator Regulator AWM20 to 40
- Micro Mist Separator Regulator AWD20 to 40







- Regulator AR20(K) to 60(K)



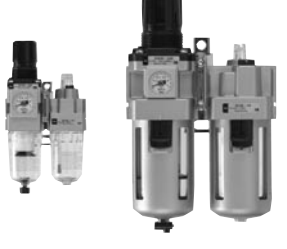



- F.R.L. Unit  
AC20 to 60 (AF+AR+AL)  
AC20A to 60A (AW+AL)  
AC20B to 60B (AF+AR)  
AC20C to 40C (AF+AFM+AR)  
AC20D to 40D (AW+AFM)

## Series Configuration





Product	Model	Port Size							Page
		M5	1/8	1/4	3/8	1/2	3/4	1	
<b>Air Filter + Regulator + Lubricator</b> <b>AF AR AL</b> 	AC10	●							1
	AC20		●	●					
	AC25			●	●				
	AC30			●	●				
	AC40			●	●	●			
	AC40-60						●		
	AC50						●	●	
	AC55							●	
	AC60							●	
<b>Filter Regulator + Lubricator</b> <b>AW AL</b> 	AC10A	●							7
	AC20A		●	●					
	AC30A			●	●				
	AC40A			●	●	●			
	AC40A-06						●		
	AC50A						●	●	
	AC60A							●	
<b>Air Filter + Regulator</b> <b>AF AR</b> 	AC10B	●							11
	AC20B		●	●					
	AC25B			●	●				
	AC30B			●	●				
	AC40B			●	●	●			
	AC40B-06						●		
	AC50B						●	●	
	AC55B							●	
	AC60B							●	
<b>Air Filter + Mist Separator + Regulator</b> <b>AF AFM AR</b> 	AC20C		●	●					15
	AC25C			●	●				
	AC30C			●	●				
	AC40C			●	●	●			
	AC40C-06						●		
<b>Filter Regulator + Mist Separator</b> <b>AW AFM</b> 	AC20D		●	●					19
	AC30D			●	●				
	AC40D			●	●	●			
	AC40D-06						●		

Air Combination

## Series Configuration

Product	Model	Port Size							Page	
		M5	1/8	1/4	3/8	1/2	3/4	1		
<b>Air Filter</b> 	<b>AF</b>	AF10	●							29
	AF20		●	●						
	AF30			●	●					
	AF40			●	●	●				
	AF40-06						●			
	AF50						●	●		
	AF60							●		
<b>Mist Separator</b> 	<b>AFM</b>	AFM20		●	●					35
	AFM30			●	●					
	AFM40			●	●	●				
	AFM40-06						●			
<b>Micro Mist Separator</b> 	<b>AFD</b>	AFD20		●	●					35
	AFD30			●	●					
	AFD40			●	●	●				
	AFD40-06						●			
<b>Regulator</b> 	<b>AR</b>	AR10	●							41
	AR20		●	●						
	AR25			●	●					
	AR30			●	●					
	AR40			●	●	●				
	AR40-06						●			
	AR50						●	●		
	AR60							●		
<b>Regulator with Backflow Mechanism</b> 	<b>AR□K</b>	AR20K		●	●					41
	AR25K			●	●					
	AR30K			●	●					
	AR40K			●	●	●				
	AR40K-06						●			
	AR50K						●	●		
	AR60K							●		

## Series Configuration

Product	Model	Port Size							Page
		M5	1/8	1/4	3/8	1/2	3/4	1	
<b>Lubricator</b> 	AL10	●							51
	AL20		●	●					
	AL30			●	●				
	AL40			●	●	●			
	AL40-06						●		
	AL50						●	●	
	AL60							●	
<b>Filter Regulator</b> 	AW10	●						59	
	AW20		●	●					
	AW30			●	●				
	AW40			●	●	●			
	AW40-06						●		
	AW60						●		●
<b>Filter Regulator with Backflow Mechanism</b> 	AW20K		●	●				59	
	AW30K			●	●				
	AW40K			●	●	●			
	AW40K-06						●		
	AW60K						●		●
<b>Mist Separator Regulator</b> 	AWM20		●	●				67	
	AWM30			●	●				
	AWM40			●	●	●			
<b>Micro Mist Separator Regulator</b> 	AWD20		●	●				67	
	AWD30			●	●				
	AWD40			●	●	●			

## Simple Specials System

A system designed to respond quickly and easily to your special ordering needs.

Simple  
**S**pecials  
 System

### Short lead times

This system enables us to respond to your special needs, such as additional machining, accessory assembly, or modular unit, and deliver such special products as quickly as standard products.

### Repeat orders

Once we receive a Simple Special part number from your previous order, we will process the order, manufacture the product, and deliver it to you.

# AC10 to AC60

JIS Symbol

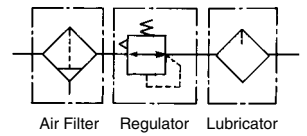

## How to Order

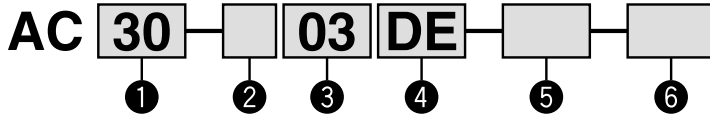

- Option / Semi-standard: Select one each for **a** to **m**.
  - Option / Attachment / Semi-standard symbol: Enter them alphanumerically.
- Example) AC30-F03DE1-KSTV-136NR

		Symbol	Description	①								
				Body size								
				10	20	25	30	40	50	55	60	
②	Thread type	-	Metric thread (M5)	●	—	—	—	—	—	—	—	
		N <small>Note 1)</small>	Rc	—	●	●	●	●	●	●	●	
		F <small>Note 2)</small>	NPT	—	●	●	●	●	●	●	●	
			G	—	●	●	●	●	●	●	●	
③	Port size	M5	M5	●	—	—	—	—	—	—	—	
		01	1/8	—	●	—	—	—	—	—	—	
		02	1/4	—	●	●	●	●	—	—	—	
		03	3/8	—	—	●	●	●	—	—	—	
		04	1/2	—	—	—	—	●	—	—	—	
		06	3/4	—	—	—	—	●	●	—	—	
		10	1	—	—	—	—	—	●	●	●	
④	a	-	Without auto drain	●	●	●	●	●	●	●	●	
		C	Float type auto drain (N.C.)	●	●	●	●	●	●	●	●	
		D	Float type auto drain (N.O.)	—	—	●	●	●	●	●	●	
	b	Pressure gauge	-	Without pressure gauge	●	●	●	●	●	●	●	●
			E	Square embedded type pressure gauge (with limit indicator)	—	●	●	●	●	●	●	●
			G	Round type pressure gauge (without limit indicator)	●	—	—	—	—	—	—	—
			G	Round type pressure gauge (with limit indicator)	—	●	●	●	●	●	●	●
		Digital pressure switch	E1	Output: NPN output / Electrical entry: Wiring bottom entry	—	●	●	●	●	●	●	●
			E2	Output: NPN output / Electrical entry: Wiring top entry	—	●	●	●	●	●	●	●
			E3	Output: PNP output / Electrical entry: Wiring bottom entry	—	●	●	●	●	●	●	●
E4	Output: PNP output / Electrical entry: Wiring top entry	—	●	●	●	●	●	●	●			
⑤	c	-	Without attachment	●	●	●	●	●	●	●	●	
		K	Mounting position: AF+AR+K+AL	—	●	●	●	●	● <small>Note 4)</small>	—	—	—
	d	-	Without attachment	●	●	●	●	●	●	●	●	
		S <small>Note 5)</small>	Mounting position: AF+AR+S+AL	—	●	●	●	●	●	●	●	
	e	-	Without attachment	●	●	●	●	●	●	●	●	
		T <small>Note 5)</small>	Mounting position: AF+T+AR+AL	●	●	●	●	●	●	●	●	
f	-	Without attachment	●	●	●	●	●	●	●	●		
	V	Mounting position: AF+AR+AL+V	—	●	●	●	●	●	●	—	—	
⑥	g	-	0.05 to 0.85 MPa set	●	●	●	●	●	●	●	●	
		1 <small>Note 6)</small>	0.02 to 0.2 MPa set	●	●	●	●	●	●	●	●	
	h	-	Polycarbonate bowl	●	●	●	●	●	●	●	●	
		2	Metal bowl	●	●	●	●	●	●	●	●	
		6	Nylon bowl	●	●	●	●	●	●	●	●	
		8	Metal bowl with level gauge	—	—	●	●	●	●	●	●	
C		With bowl guard	—	●	—	—	—	—	—	—		
6C	Nylon bowl with bowl guard	—	●	—	—	—	—	—	—			

# Air Combination Series AC10 to AC60

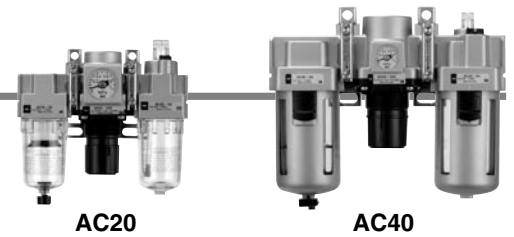

		Symbol	Description	①									
				Body size									
				10	20	25	30	40	50	55	60		
⑥	i	Filter Drain port <small>Note 7)</small>	-	With drain cock	●	●	●	●	●	●	●	●	
			J <small>Note 8)</small>	Drain guide 1/8	—	●	—	—	—	—	—	—	
			—	Drain guide 1/4	—	—	●	●	●	●	●	●	●
			W <small>Note 9)</small>	Drain cock with barb fitting: For ø6 x ø4 nylon tube	—	—	●	●	●	●	●	●	●
			+										
	j	Lubricator Lubricant discharge port	-	Without drain cock	●	●	●	●	●	●	●	●	
			3 <small>Note 10)</small>	Lubricator with drain cock	●	●	●	●	●	●	●	●	●
			+										
	k	Exhaust mechanism	-	Relieving type	●	●	●	●	●	●	●	●	
			N	Non-relieving type	●	●	●	●	●	●	●	●	●
			+										
	l	Flow direction	-	Flow direction: Left to right	●	●	●	●	●	●	●	●	
R			Flow direction: Right to left	●	●	●	●	●	●	●	●	●	
		+											
m	Pressure unit	-	Name plate and pressure gauge in SI units: MPa	●	●	●	●	●	●	●	●		
		Z <small>Note 11)</small>	Name plate, caution plate for bowl, and pressure gauge in imperial units (PSI, °F)	○ <small>Note 13)</small>	○ <small>Note 13)</small>	○ <small>Note 13)</small>	○ <small>Note 13)</small>	○ <small>Note 13)</small>	○ <small>Note 13)</small>	○ <small>Note 13)</small>	○ <small>Note 13)</small>	○ <small>Note 13)</small>	
		ZA <small>Note 12)</small>	Digital pressure switch: With unit switching function	—	△ <small>Note 14)</small>	△ <small>Note 14)</small>	△ <small>Note 14)</small>	△ <small>Note 14)</small>	△ <small>Note 14)</small>	△ <small>Note 14)</small>	△ <small>Note 14)</small>	△ <small>Note 14)</small>	

Note 1) Drain guide is NPT1/8 (applicable to the AC20) and NPT1/4 (applicable to the AC25 to AC60). The exhaust port for auto drain comes with a ø3/8" One-touch fitting (applicable to the AC25 to AC60).

Note 2) Drain guide is G1/8 (applicable to the AC20) and G1/4 (applicable to the AC25 to AC60).

Note 3) Option G is not assembled and is supplied loose at the time of shipment.

Note 4) Not available with piping port size 06.

Note 5) The bracket position varies depending on the T-interface or the pressure switch mounting.

Note 6) The only difference from the standard specifications is the adjusting spring for the regulator. It does not restrict the setting of 0.2 MPa or more. When the pressure gauge is attached, a 0.2 MPa pressure gauge will be fitted.

Note 7) Float type auto drain: The combination between C or D is not available with the drain port option.

Note 8) Without a valve function

Note 9) Metal bowl: The combination of 2 or 8 cannot be selected with W.

Note 10) Filter drain port: When choosing with W, the drain cock of a lubricator will be with barb fittings.

Note 11) For thread type: M5 and NPT. This product is for overseas use only according to the new Measurement Law. (The SI unit type is provided for use in Japan.) The digital pressure switch will be equipped with the unit switching function, setting to PSI initially.

Note 12) For options: E1, E2, E3, E4. This product is for overseas use only according to the new Measurement Law. (The SI unit is provided for use in Japan.)

Note 13) ○: For thread type: M5 and NPT only

Note 14) △: Combination available for options: E1, E2, E3, E4.

## Standard Specifications

Model	AC10	AC20	AC25	AC30	AC40	AC40-06	AC50	AC55	AC60	
Component	Air filter	AF10	AF20	AF30	AF30	AF40	AF40-06	AF50	AF60	AF60
	Regulator	AR10	AR20	AR25	AR30	AR40	AR40-06	AR50	AR50	AR60
	Lubricator	AL10	AL20	AL30	AL30	AL40	AL40-06	AL50	AL60	AL60
Port size	M5	1/8, 1/4	1/4, 3/8	1/4, 3/8	1/4, 3/8, 1/2	3/4	3/4, 1	1	1	
Pressure gauge port size <small>Note 1)</small>	1/16	1/8		1/4			1/4			
Fluid	Air									
Ambient and fluid temperature <small>Note 2)</small>	-5 to 60°C (with no freezing)									
Proof pressure	1.5 MPa									
Max. operating pressure	1.0 MPa									
Set pressure range	0.05 to 0.7 MPa	0.05 to 0.85 MPa								
Relief pressure	Set pressure + 0.05 MPa <small>Note 3)</small> [at relief flow rate of 0.1 l/min (ANR)]									
Nominal filtration rating	5 µm									
Recommended lubricant	Class 1 turbine oil (ISO VG32)									
Bowl material	Polycarbonate									
Bowl guard	—	Semi-standard	Standard							
Regulator construction	Relieving type									
Weight (kg)	0.27	0.73	0.91	1.00	1.74	1.95	4.17	4.25	4.34	

Note 1) Pressure gauge connection threads are not available for F.R.L. units with a square embedded type pressure gauge or with a digital pressure switch (the AC20 to AC60).

Note 2) -5 to 50°C for the products with the digital pressure switch

Note 3) Not applicable for AC10.

# Series AC10 to AC60

## Flow Characteristics (Representative values)

Condition: Inlet pressure 0.7 MPa

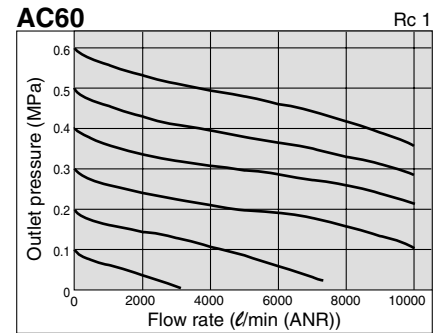
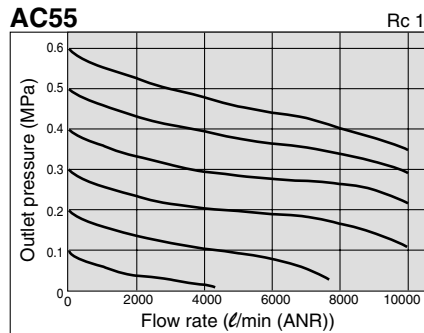
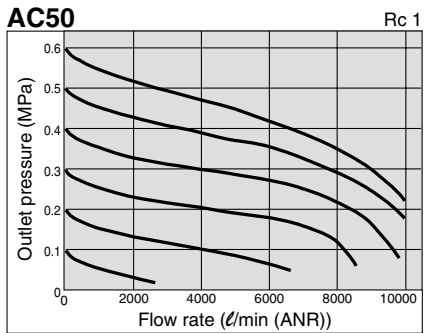
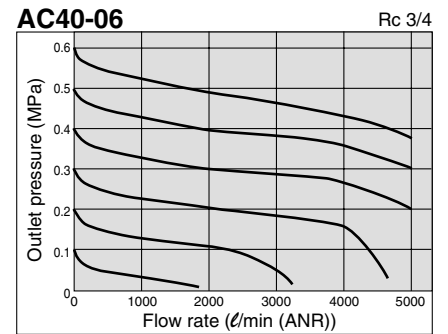
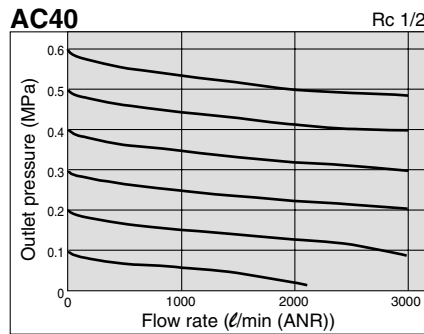
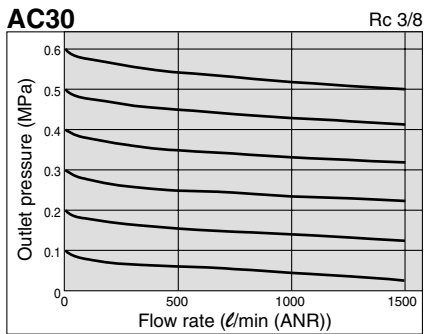
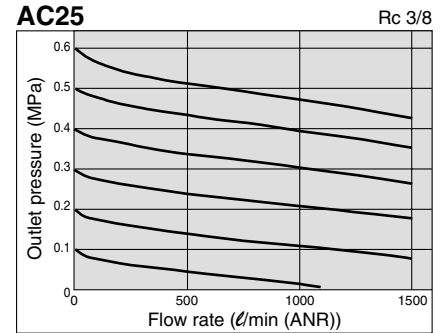
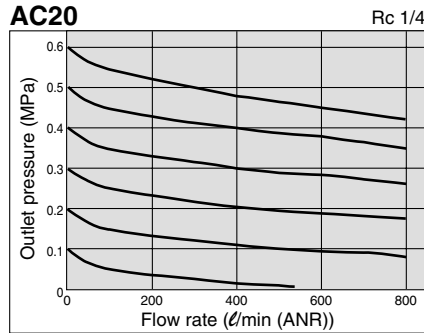
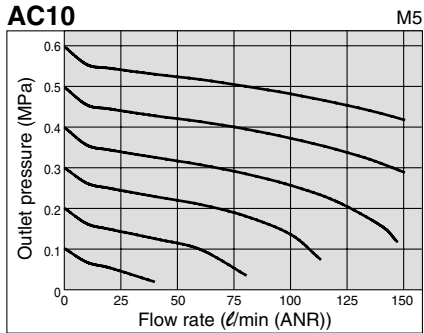

## Pressure Characteristics (Representative values)

Conditions: Inlet pressure 0.7 MPa, Outlet pressure 0.2 MPa, Flow rate 20 l/min (ANR)

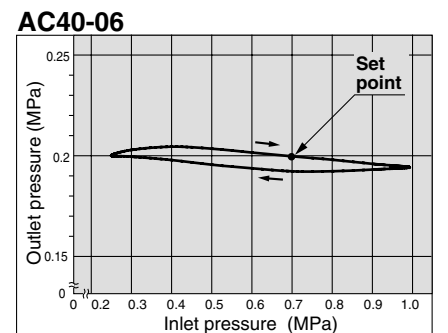
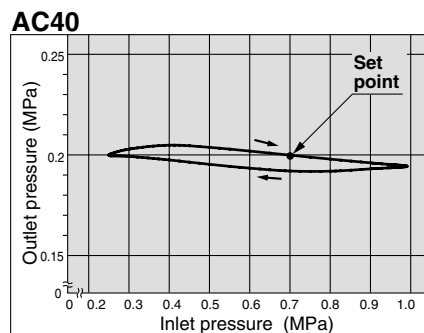
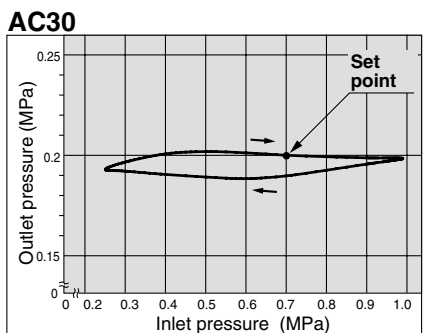
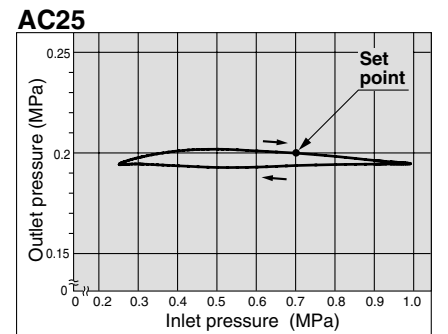
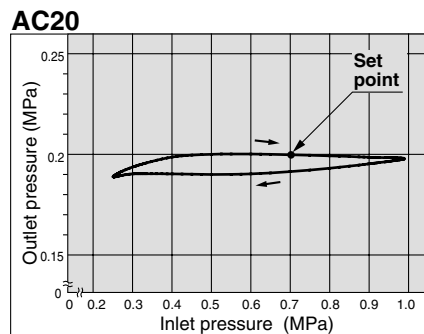
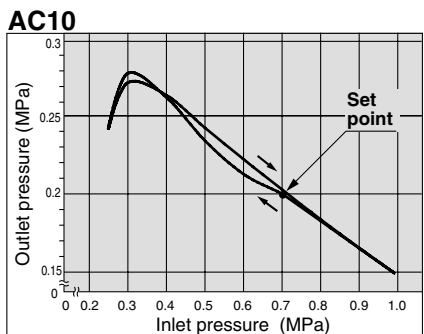

## Pressure Characteristics (Representative values)

Conditions: Inlet pressure 0.7 MPa, Outlet pressure 0.2 MPa, Flow rate 20 l/min (ANR)

**AC50**

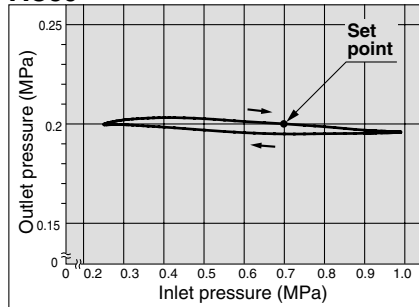

**AC55**

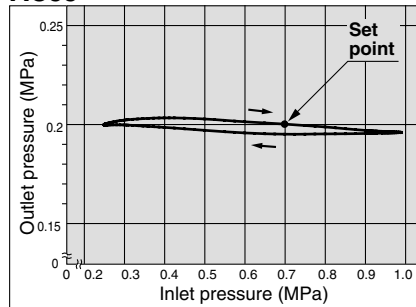

**AC60**

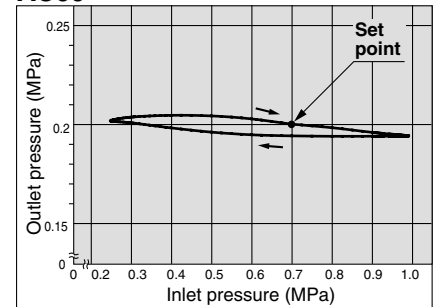

## ⚠ Specific Product Precautions

### Mounting and Adjustment

#### ⚠ Caution

1. A knob cover is available to prevent careless operation of the knob. Refer to "Features 1" for details.

### Piping

#### ⚠ Warning

1. When mounting a check valve, make sure the arrow (IN side) points in the correct direction of air flow.

### Air Supply

#### ⚠ Caution

1. Use an air filter with 5 μm or less filtration rating on the inlet side of the valve to avoid any damage to the seat caused by dust when mounting a 3-port valve for residual pressure release on the inlet side.

### Selection

#### ⚠ Warning

1. Float type auto drain

Operate under the following conditions to avoid malfunction.

<N.O. type>

- Operating compressor: 0.75 kW (100 l/min (ANR)) or more.

When using 2 or more auto drains, multiply the value above by the number of auto drains to find the capacity of the compressors you will need.

For example, when using 2 auto drains, 1.5 kW (200 l/min (ANR)) of compressor capacity is required.

- Operating pressure: 0.1 MPa or more.

<N.C. type>

- Operating pressure for AD17/27: 0.1 MPa or more.

- Operating pressure for AD37/47: 0.15 MPa or more.

2. Use a regulator or filter regulator with backflow mechanism when mounting a 3-port valve for residual pressure release on the IN side to ensure the release of the residual pressure. Otherwise, residual pressure will not be fully released.

#### ⚠ Caution

1. When releasing air at the intermediate position using a T-interface on the inlet side of the lubricator, lubricant may back flow. Therefore, releasing air that does not contain traces of lubricant is not possible.

To release air that does not contain traces of lubricant, use a check valve (the AKM series) on the inlet side of the lubricator to prevent a back flow of the lubricant.

2. Mounting a 3-port valve for residual pressure release on the IN side of the lubricator can cause lubricant to back flow. Take measures to prevent lubricant from splashing by installing a filter on the EXH port.

3. An F.R.L. unit shipped from the plant has its model number labeled. However, components that are combined together during the distribution process do not have a label on them.

# Series AC10 to AC60

## Dimensions

### AC10, AC20

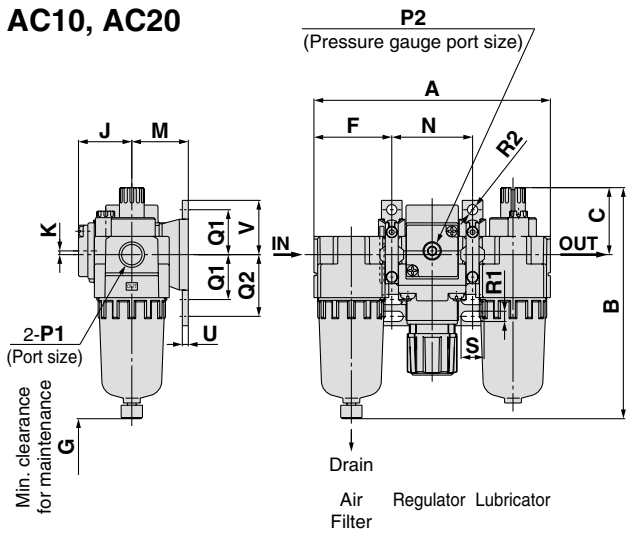

### AC25 to AC60

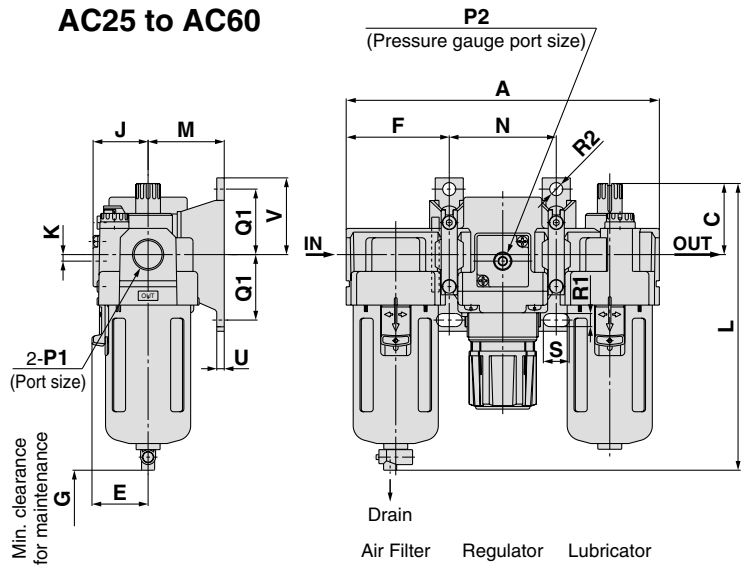

Applicable model	AC20 to AC60		AC10 to AC60
Option	Square embedded type pressure gauge	Digital pressure switch	Round type pressure gauge
Dimensions			

Applicable model	AC10, AC20		AC20	AC25 to AC60				
Optional/Semi-standard specifications	With auto drain (N.C.)	Metal bowl	With drain guide	With auto drain (N.O./N.C.)	Metal bowl	Metal bowl with level gauge	With drain guide	Drain cock with barb fitting
Dimensions								

Model	Standard specifications										Optional specifications					
	P1	P2	A	B	C	E	F	G	J	K	Square type pressure gauge	Digital pressure gauge	Round type pressure gauge	H	J	
AC10	M5	1/16	87	85	26	—	28	35	13	0	—	—	—	ø26	26	
AC20	1/8, 1/4	1/8	126	123	36	—	41.5	60	28.5	2 <sup>Note)</sup>	□28	29.5	□27.8	40	ø37.5	65
AC25	1/4, 3/8	1/8	167	153	38	30	55	80	27.5	0	□28	28.5	□27.8	39	ø37.5	64
AC30	1/4, 3/8	1/8	167	153	38	30	55	80	29.5	3.5	□28	30.5	□27.8	41	ø37.5	66
AC40	1/4, 3/8, 1/2	1/4	220	187	40	38	72.5	110	34	3.5	□28	35	□27.8	45	ø42.5	74
AC40-06	3/4	1/4	235	187	38	38	77.5	110	34	3	□28	35	□27.8	45	ø42.5	74
AC50	3/4, 1	1/4	282	264	43	45	93	110	43.5	3.3	□28	44.5	□27.8	55	ø42.5	84
AC55	1	1/4	292	279	45	47.5	98	110	43.5	3.3	□28	44.5	□27.8	55	ø42.5	84
AC60	1	1/4	297	280	46	47.5	98	110	43.5	3.3	□28	44.5	□27.8	55	ø42.5	84

Model	Optional specifications										Semi-standard specifications				
	Bracket mount										With auto drain	With barb fitting	With drain guide	Metal bowl	Metal bowl with level gauge
	M	N	Q1	Q2	R1	R2	S	U	V	B	B	B	B	B	
AC10	25	31	20	27	4.5	ø4.5	7	2.8	24.5	104	—	—	85	—	
AC20	30	43	24	33	5.5	ø5.5	12	3.2	29	141	—	127	123	—	
AC25	41	57	35	—	7	ø7	14	4	41	194	161	160	166	186	
AC30	41	57	35	—	7	ø7	14	4	41	194	161	160	166	186	
AC40	50	75	40	—	9	ø9	18	4	48	226	195	194	200	220	
AC40-06	50	80	40	—	9	ø9	18	4.6	48	226	195	194	200	220	
AC50	70	96	50	—	11	ø11	20	6.4	60	303	272	271	276	296	
AC55	70	96	50	—	11	ø11	20	6.4	60	318	287	286	292	312	
AC60	70	101	50	—	11	ø11	20	6.4	60	319	288	287	293	313	

Note) For the AC20 only, the position of the pressure gauge is above the centre of the piping.



JIS Symbol

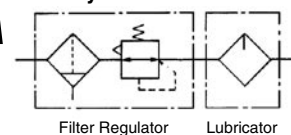

## How to Order

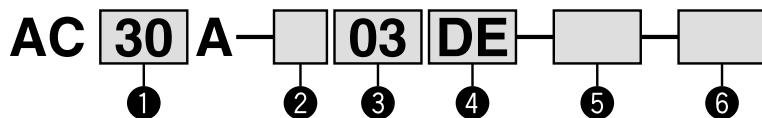

- Option / Semi-standard: Select one each for a to l.
  - Option / Attachment / Semi-standard symbol: Enter them alphanumerically.
- Example) AC30A-F03DE1-KSV-136NR

		Symbol	Description	①						
				Body size						
				10	20	30	40	50	60	
②	Thread type	-	Metric thread (M5)	●	—	—	—	—	—	
		N <small>Note 1)</small>	Rc	—	●	●	●	●	●	
		F <small>Note 2)</small>	NPT	—	●	●	●	●	●	
			G	—	●	●	●	●	●	
+										
③	Port size	M5	M5	●	—	—	—	—	—	
		01	1/8	—	●	—	—	—	—	
		02	1/4	—	●	●	—	—	—	
		03	3/8	—	—	●	●	—	—	
		04	1/2	—	—	—	●	—	—	
		06	3/4	—	—	—	—	●	—	
		10	1	—	—	—	—	●	●	
+										
④	a	-	Without auto drain	●	●	●	●	●	●	
		C	Float type auto drain (N.C.)	●	●	●	●	●	●	
		D	Float type auto drain (N.O.)	—	—	●	●	●	●	
	+									
	b	Pressure gauge	-	Without pressure gauge	●	●	●	●	●	●
			E	Square embedded type pressure gauge (with limit indicator)	—	●	●	●	●	●
			G	Round type pressure gauge (without limit indicator)	●	—	—	—	—	—
				Round type pressure gauge (with limit indicator)	—	●	●	●	●	●
		Digital pressure switch	E1	Output: NPN output / Electrical entry: Wiring bottom entry	—	●	●	●	●	●
			E2	Output: NPN output / Electrical entry: Wiring top entry	—	●	●	●	●	●
			E3	Output: PNP output / Electrical entry: Wiring top entry	—	●	●	●	●	●
	E4	Output: PNP output / Electrical entry: Wiring bottom entry	—	●	●	●	●	●		
+										
⑤	c	-	Without attachment	●	●	●	●	●	●	
		K	Mounting position: AW+K+AL	—	●	●	● <small>Note 4)</small>	—	—	
	+									
	d	-	Without attachment	●	●	●	●	●	●	
		S <small>Note 5)</small>	Mounting position: AW+S+AL	—	●	●	●	●	●	
	+									
e	-	Without attachment	●	●	●	●	●	●		
	V	Mounting position: AW+AL+V	—	●	●	●	●	—		
+										
⑥	f	-	0.05 to 0.85 MPa set	●	●	●	●	●	●	
		1 <small>Note 6)</small>	0.02 to 0.2 MPa set	●	●	●	●	●	●	
	+									
	g	Bowl	-	Polycarbonate bowl	●	●	●	●	●	●
			2	Metal bowl	●	●	●	●	●	●
			6	Nylon bowl	●	●	●	●	●	●
			8	Metal bowl with level gauge	—	—	●	●	●	●
			C	With bowl guard	—	●	—	—	—	—
			6C	Nylon bowl with bowl guard	—	●	—	—	—	—
	+									
	h	Filter regulator Drain port <small>Note 7)</small>	-	With drain cock	●	●	●	●	●	●
			J <small>Note 8)</small>	Drain guide 1/8	—	●	—	—	—	—
			Drain guide 1/4	—	—	●	●	●	●	
W <small>Note 9)</small>			Drain cock with barb fitting: For ø6 x ø4 nylon tube	—	—	●	●	●	●	

# Air Combination Series AC10A to AC60A

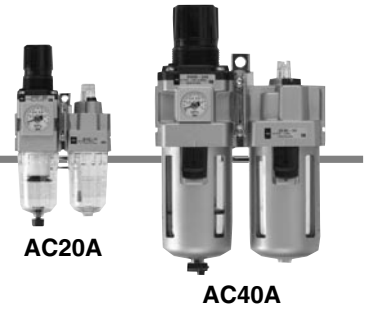

		Symbol	Description	①							
				Body size							
				10	20	30	40	50	60		
⑥	Semi-standard	i	Lubricator Lubricant discharge port	-	Without drain cock	●	●	●	●	●	●
			3	Lubricator with drain cock	●	●	●	●	●	●	
				+							
	j	Exhaust mechanism	-	Relieving type	●	●	●	●	●	●	
			N	Non-relieving type	●	●	●	●	●	●	
			+								
	k	Flow direction	-	Flow direction: Left to right	●	●	●	●	●	●	
			R	Flow direction: Right to left	●	●	●	●	●	●	
			+								
	l	Pressure unit	-	Name plate and pressure gauge in SI units: MPa	●	●	●	●	●	●	
			Z <sup>Note 10)</sup>	Name plate, caution plate for bowl, and pressure gauge in imperial units (PSI, °F)	○ <sup>Note 12)</sup>	○ <sup>Note 12)</sup>	○ <sup>Note 12)</sup>	○ <sup>Note 12)</sup>	○ <sup>Note 12)</sup>	○ <sup>Note 12)</sup>	
			ZA <sup>Note 11)</sup>	Digital pressure switch: With unit switching function	—	△ <sup>Note 13)</sup>	△ <sup>Note 13)</sup>	△ <sup>Note 13)</sup>	△ <sup>Note 13)</sup>	△ <sup>Note 13)</sup>	

Note 1) Drain guide is NPT1/8 (applicable to the AC20A) and NPT1/4 (applicable to the AC30A to AC60A). The exhaust port for auto drain comes with a  $\phi 3/8$ " One-touch fitting (applicable to the AC30A to AC60A).

Note 2) Drain guide is G1/8 (applicable to the AC20A) and G1/4 (applicable to the AC30A to AC60A).

Note 3) Option G is not assembled and is supplied loose at the time of shipment.

Note 4) Not available with piping port size 06.

Note 5) The bracket position varies depending on the pressure switch mounting.

Note 6) The only difference from the standard specifications is the adjusting spring for the regulator. It does not restrict the setting of 0.2 MPa or more. When the pressure gauge is attached, a 0.2 MPa pressure gauge will be fitted.

Note 7) Float type auto drain: The combination between C or D is not available with the drain port options.

Note 8) Without a valve function

Note 9) Metal bowl: The combination of 2 or 8 cannot be selected with W.

Note 10) For thread type: M5 and NPT. This product is for overseas use only according to the new Measurement Law. (The SI unit type is provided for use in Japan.) The digital pressure switch will be equipped with the unit switching function, setting to PSI initially.

Note 11) For options: E1, E2, E3, E4. This product is for overseas use only according to the new Measurement Law. (The SI unit is provided for use in Japan.)

Note 12) ○: For thread type: M5 and NPT only

Note 13) △: Combination available for options: E1, E2, E3, E4.

## Standard Specifications

Model		AC10A	AC20A	AC30A	AC40A	AC40A-06	AC50A	AC60A
Component	Filter regulator	AW10	AW20	AW30	AW40	AW40-06	AW60	AW60
	Lubricator	AL10	AL20	AL30	AL40	AL40-06	AL50	AL60
Port size		M5	1/8, 1/4	1/4, 3/8	1/4, 3/8, 1/2	3/4	3/4, 1	1
Pressure gauge port size <sup>Note 1)</sup>		1/16	1/8		1/4			
Fluid		Air						
Ambient and fluid temperature <sup>Note 2)</sup>		-5 to 60°C (with no freezing)						
Proof pressure		1.5 MPa						
Maximum operating pressure		1.0 MPa						
Set pressure range		0.05 to 0.7 MPa	0.05 to 0.85 MPa					
Relief pressure		Set pressure + 0.05 MPa <sup>Note 3)</sup> [at relief flow rate of 0.1 ℓ/min (ANR)]						
Nominal filtration rating		5 μm						
Recommended lubricant		Class 1 turbine oil (ISO VG32)						
Bowl material		Polycarbonate						
Bowl guard		—	Semi-standard	Standard				
Regulator construction		Relieving type						
Weight (kg)		0.20	0.59	0.75	1.41	1.46	3.33	3.40

Note 1) Pressure gauge connection threads are not available for F.R.L. units with a square embedded type pressure gauge or with a digital pressure switch (the AC20A to AC60A).

Note 2) -5 to 50°C for the products with the digital pressure switch

Note 3) Not applicable for AC10A.

# Series AC10A to AC60A

## Dimensions

### AC10A, AC20A

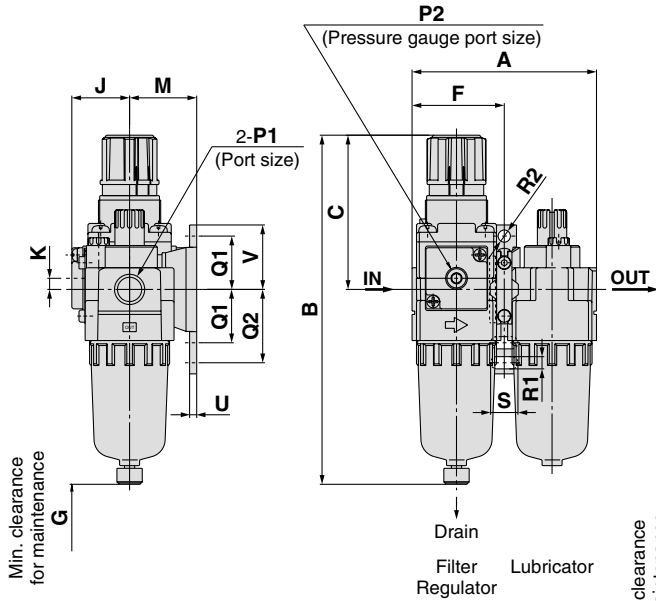

### AC30A to AC60A

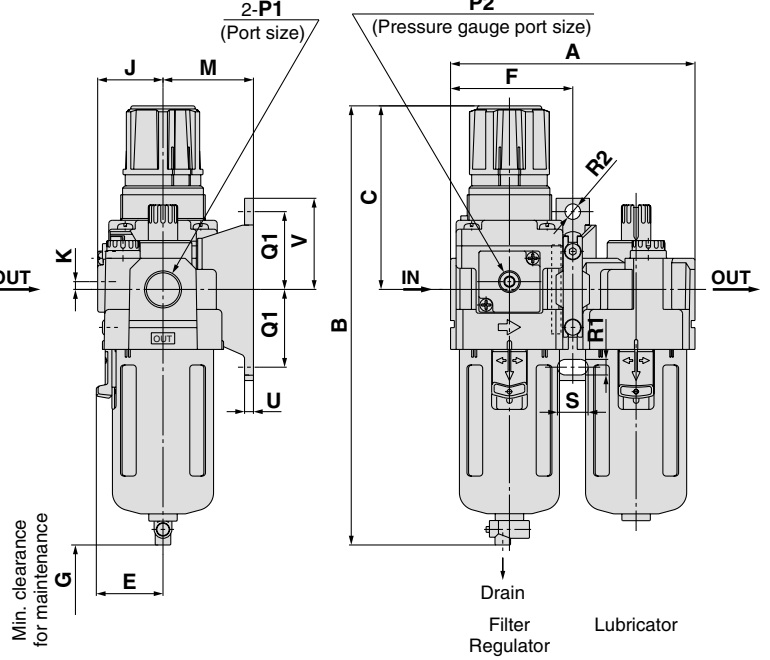

Applicable model	AC20A to AC60A		AC10A to AC60A
Option	Square embedded type pressure gauge	Digital pressure switch	Round type pressure gauge
Dimensions			

Applicable model	AC10A, AC20A		AC20A	AC30A to AC60A				
Optional/Semi-standard specifications	With auto drain (N.C.)	Metal bowl	With drain guide	With auto drain (N.O./N.C.)	Metal bowl	Metal bowl with level gauge	With drain guide	Drain cock with barb fitting
Dimensions								

Model	Standard specifications										Optional specifications					
	P1	P2	A	B (Note)	C	E	F	G	J	K	Square type pressure gauge	Digital pressure gauge	Round type pressure gauge	J	H	J
AC10A	M5	1/16	56	108	48	—	28	35	13	0	—	—	—	—	—	—
AC20A	1/8, 1/4	1/8	83	160	73	—	41.5	60	26	5	□28	27	□27.8	37.5	ø37.5	63
AC30A	1/4, 3/8	1/8	110	201	86	30	55	80	29.5	3.5	□28	30.5	□27.8	41	ø37.5	66
AC40A	1/4, 3/8, 1/2	1/4	145	239	92	38	72.5	110	37.5	1.5	□28	38.5	□27.8	49	ø42.5	76
AC40A-06	3/4	1/4	155	242	93	38	77.5	110	37.5	1.2	□28	38.5	□27.8	49	ø42.5	76
AC50A	3/4, 1	1/4	191	409	175	—	98	110	43.5	3.2	□28	44.5	□27.8	61.5	ø42.5	84
AC60A	1	1/4	196	409	175	—	98	110	43.5	3.2	□28	44.5	□27.8	61.5	ø42.5	84

Model	Optional specifications								Semi-standard specifications				
	Bracket mount								With auto drain	With barb fitting	With drain guide	Metal bowl	Metal bowl with level gauge
	M	Q1	Q2	R1	R2	S	U	V	B	B	B	B	B
AC10A	25	20	27	4.5	ø4.5	7	2.8	24.5	125	—	—	107	—
AC20A	30	24	33	5.5	ø5.5	12	3.2	29	177	—	164	160	—
AC30A	41	35	—	7	ø7	14	4	41	242	209	208	214	234
AC40A	50	40	—	9	ø9	18	4	48	278	247	246	252	272
AC40A-06	50	40	—	9	ø9	18	4.6	48	282	251	249	255	275
AC50A	70	50	—	11	ø11	20	6.4	60	448	417	416	422	442
AC60A	70	50	—	11	ø11	20	6.4	60	448	417	416	422	442

Note) The total length of B dimension is the length when the filter regulator handle is unlocked.



# AC10B to AC60B

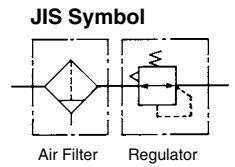

## How to Order

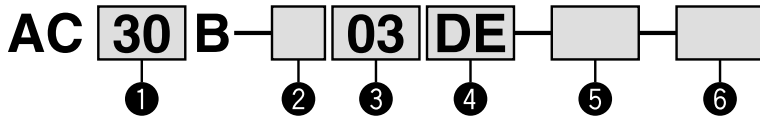

- Option / Semi-standard: Select one each for a to j.
  - Option / Attachment / Semi-standard symbol: Enter them alphanumerically.
- Example) AC30B-F03DE1-SV-16NR

		Symbol	Description	①								
				Body size								
				10	20	25	30	40	50	55	60	
②	Thread type	-	Metric thread (M5)	●	—	—	—	—	—	—	—	
		N <sup>Note 1)</sup>	Rc	—	●	●	●	●	●	●	●	
		F <sup>Note 2)</sup>	NPT	—	●	●	●	●	●	●	●	
			G	—	●	●	●	●	●	●	●	
+												
③	Port size	M5	M5	●	—	—	—	—	—	—	—	
		01	1/8	—	●	—	—	—	—	—	—	
		02	1/4	—	●	●	●	●	—	—	—	
		03	3/8	—	—	●	●	●	—	—	—	
		04	1/2	—	—	—	—	●	—	—	—	
		06	3/4	—	—	—	—	●	●	—	—	
		10	1	—	—	—	—	—	●	●	●	
+												
④	a	-	Without auto drain	●	●	●	●	●	●	●	●	
		C	Float type auto drain (N.C.)	●	●	●	●	●	●	●	●	
		D	Float type auto drain (N.O.)	—	—	●	●	●	●	●	●	
	+											
	b	Pressure gauge	-	Without pressure gauge	●	●	●	●	●	●	●	●
			E	Square embedded type pressure gauge (with limit indicator)	—	●	●	●	●	●	●	●
			G	Round type pressure gauge (without limit indicator)	●	—	—	—	—	—	—	—
				Round type pressure gauge (with limit indicator)	—	●	●	●	●	●	●	●
		Digital pressure switch	E1	Output: NPN output / Electrical entry: Wiring bottom entry	—	●	●	●	●	●	●	●
			E2	Output: NPN output / Electrical entry: Wiring top entry	—	●	●	●	●	●	●	●
E3			Output: PNP output / Electrical entry: Wiring bottom entry	—	●	●	●	●	●	●	●	
	E4	Output: PNP output / Electrical entry: Wiring top entry	—	●	●	●	●	●	●	●		
+												
⑤	c	-	Without attachment	●	●	●	●	●	●	●	●	
		S <sup>Note 4)</sup>	Mounting position: AF+S+AR	—	●	●	●	●	●	●	●	
		T <sup>Note 4)</sup>	Mounting position: AF+T+AR	●	●	●	●	●	●	●	●	
	+											
d	3-port valve for residual pressure release	-	Without attachment	●	●	●	●	●	●	●	●	
		V	Mounting position: AF+AR+V	—	●	●	●	●	●	—	—	
		V1 <sup>Note 5)</sup>	Mounting position: V+AF+AR□K	—	●	●	●	●	●	—	—	
+												
⑥	e	-	0.05 to 0.85 MPa set	●	●	●	●	●	●	●	●	
		1 <sup>Note 6)</sup>	0.02 to 0.2 MPa set	●	●	●	●	●	●	●	●	
	+											
	f	Bowl	-	Polycarbonate bowl	●	●	●	●	●	●	●	●
			2	Metal bowl	●	●	●	●	●	●	●	●
			6	Nylon bowl	●	●	●	●	●	●	●	●
			8	Metal bowl with level gauge	—	—	●	●	●	●	●	●
			C	With bowl guard	—	●	—	—	—	—	—	—
			6C	Nylon bowl with bowl guard	—	●	—	—	—	—	—	—
	+											
g	Filter Drain port <sup>Note 7)</sup>	-	With drain cock	●	●	●	●	●	●	●	●	
		J <sup>Note 8)</sup>	Drain guide 1/8	—	●	—	—	—	—	—	—	
			Drain guide 1/4	—	—	●	●	●	●	●	●	
		W <sup>Note 9)</sup>	Drain cock with barb fitting: For ø6 x ø4 nylon tube	—	—	●	●	●	●	●	●	

# Air Combination *Series AC10B to AC60B*

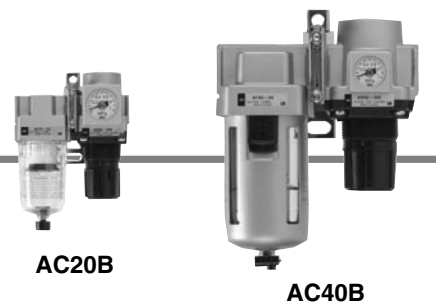

		Symbol	Description	①								
				Body size								
				10	20	25	30	40	50	55	60	
⑥	h	Exhaust mechanism	-	Relieving type	●	●	●	●	●	●	●	●
			N	Non-relieving type	●	●	●	●	●	●	●	●
			+									
	i	Flow direction	-	Flow direction: Left to right	●	●	●	●	●	●	●	●
			R	Flow direction: Right to left	●	●	●	●	●	●	●	●
			+									
j	Pressure unit	-	Name plate and pressure gauge in SI units: MPa	●	●	●	●	●	●	●	●	
		Z <small>Note 10</small>	Name plate, caution plate for bowl, and pressure gauge in imperial units (PSI, °F)	○ <small>Note 12</small>	○ <small>Note 12</small>	○ <small>Note 12</small>	○ <small>Note 12</small>	○ <small>Note 12</small>	○ <small>Note 12</small>	○ <small>Note 12</small>	○ <small>Note 12</small>	
		ZA <small>Note 11</small>	Digital pressure switch: With unit switching function	—	△ <small>Note 13</small>	△ <small>Note 13</small>	△ <small>Note 13</small>	△ <small>Note 13</small>	△ <small>Note 13</small>	△ <small>Note 13</small>	△ <small>Note 13</small>	

Note 1) Drain guide is NPT1/8 (applicable to the AC20B) and NPT1/4 (applicable to the AC25B to AC60B). The exhaust port for auto drain comes with a  $\varnothing 3/8"$  One-touch fitting (applicable to the AC25B to AC60B).

Note 2) Drain guide is G1/8 (applicable to the AC20B) and G1/4 (applicable to the AC25B to AC60B).

Note 3) Option G is not assembled and is supplied loose at the time of shipment.

Note 4) The bracket position varies depending on the T-interface or the pressure switch mounting.

Note 5) In this configuration the regulator is equipped with a back from mechanism. Additionally, for safety purposes, please check that the pressure on the outlet side is at atmospheric pressure after the pressure on the outlet side is exhausted, by using a pressure gauge, etc.

Note 6) The only difference from the standard specifications is the adjusting spring for the regulator. It does not restrict the setting of 0.2 MPa or more. When the pressure gauge is attached, a 0.2 MPa pressure gauge will be fitted.

Note 7) Float type auto drain: The combination between C or D is not available with the drain port options.

Note 8) Without a valve function

Note 9) Metal bowl: The combination of 2 or 8 cannot be selected with W.

Note 10) For thread type: M5 and NPT. This product is for overseas use only according to the new Measurement Law. (The SI unit type is provided for use in Japan.) The digital pressure switch will be equipped with the unit switching function, setting to PSI initially.

Note 11) For options: E1, E2, E3, E4. This product is for overseas use only according to the new Measurement Law. (The SI unit is provided for use in Japan.)

Note 12) ○: For thread type: M5 and NPT only

Note 13) △: Combination available for options: E1, E2, E3, E4.

## Standard Specifications

Model		AC10B	AC20B	AC25B	AC30B	AC40B	AC40B-06	AC50B	AC55B	AC60B
Component	Air filter	AF10	AF20	AF30	AF30	AF40	AF40-06	AF50	AF60	AF60
	Regulator	AR10	AR20	AR25	AR30	AR40	AR40-06	AR50	AR50	AR60
Port size		M5	1/8, 1/4	1/4, 3/8	1/4, 3/8	1/4, 3/8, 1/2	3/4	3/4, 1	1	1
Pressure gauge port size <small>Note 1)</small>		1/16	1/8		1/4					
Fluid		Air								
Ambient and fluid temperature <small>Note 2)</small>		-5 to 60°C (with no freezing)								
Proof pressure		1.5 MPa								
Maximum operating pressure		1.0 MPa								
Set pressure range		0.05 to 0.7 MPa	0.05 to 0.85 MPa							
Relief pressure		Set pressure + 0.05 MPa <small>Note 3)</small> [at relief flow rate of 0.1 ℓ/min (ANR)]								
Nominal filtration rating		5 μm								
Bowl material		Polycarbonate								
Bowl guard		—	Semi-standard	Standard						
Regulator construction		0.16 Relieving type								
Weight (kg)			0.51	0.55	0.63	1.12	1.16	2.44	2.45	2.54

Note 1) Pressure gauge connection threads are not available for F.R.L. units with a square embedded type pressure gauge or with a digital pressure switch (the AC10B to AC60B).

Note 2) -5 to 50°C for the products with the digital pressure switch

Note 3) Not applicable for AC10B.

# Series AC10B to AC60B

## Dimensions

### AC10B, AC20B

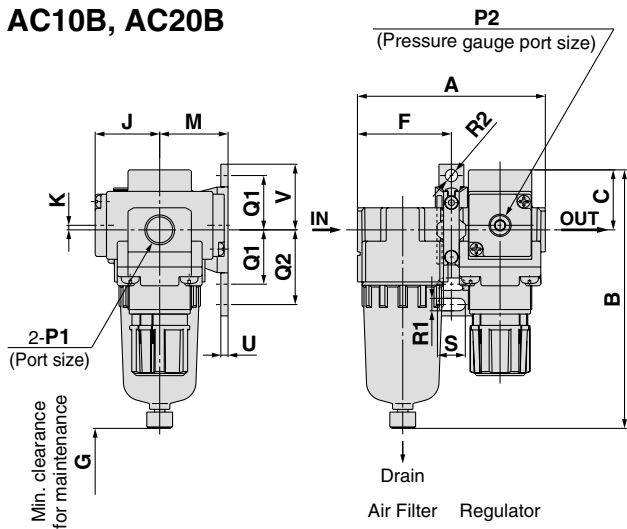

### AC25B to AC60B

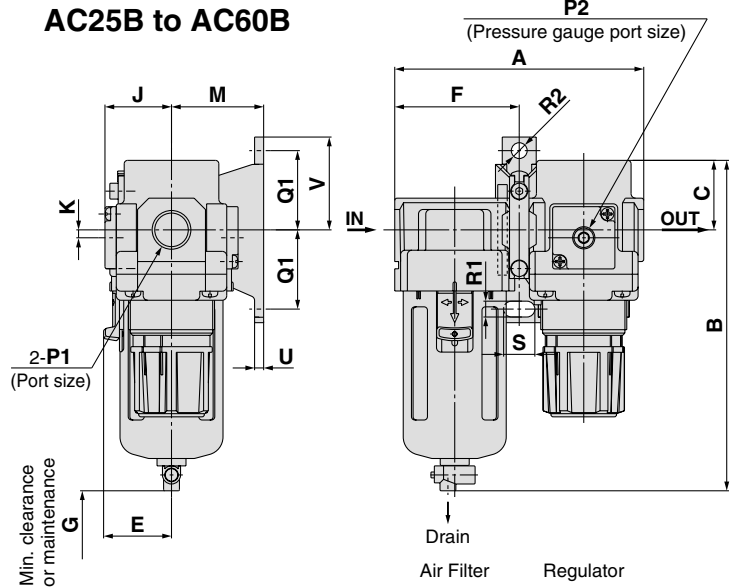

Applicable model	AC20B to AC60B		AC10B to AC60B
Option	Square embedded type pressure gauge	Digital pressure switch	Round type pressure gauge
Dimensions			

Applicable model	AC10B, AC20B		AC20B	AC25B to AC60B				
Optional/Semi-standard specifications	With auto drain (N.C.)	Metal bowl	With drain guide	With auto drain (N.O./N.C.)	Metal bowl	Metal bowl with level gauge	With drain guide	Drain cock with barb fitting
Dimensions								

Model	Standard specifications										Optional specifications					
	P1	P2	A	B	C	E	F	G	J	K	Square type pressure gauge	Digital pressure gauge	Round type pressure gauge			
AC10B	M5	1/16	56	71	11	—	28	25	13	0	—	—	—	—	—	
AC20B	1/8, 1/4	1/8	83	114	26.5	—	41.5	40	28.5	2 <sup>Note)</sup>	□28	29.5	□27.8	40	ø37.5	65
AC25B	1/4, 3/8	1/8	110	143	28	30	55	50	27.5	0	□28	28.5	□27.8	39	ø37.5	64
AC30B	1/4, 3/8	1/8	110	146	31	30	55	50	29.5	3.5	□28	30.5	□27.8	41	ø37.5	66
AC40B	1/4, 3/8, 1/2	1/4	145	183	36	38	72.5	75	34	3.5	□28	35	□27.8	45	ø42.5	74
AC40B-06	3/4	1/4	155	185	36	38	77.5	75	34	3	□28	35	□27.8	45	ø42.5	74
AC50B	3/4, 1	1/4	186	263	43	45	93	20	43.5	3.3	□28	44.5	□27.8	55	ø42.5	84
AC55B	1	1/4	191	277	43	47.5	98	20	43.5	3.3	□28	44.5	□27.8	55	ø42.5	84
AC60B	1	1/4	196	280	46	47.5	98	20	43.5	3.3	□28	44.5	□27.8	55	ø42.5	84

Model	Optional specifications								Semi-standard specifications				
	Bracket mount								With auto drain	With barb fitting	With drain guide	Metal bowl	Metal bowl with level gauge
	M	Q1	Q2	R1	R2	S	U	V	B	B	B	B	B
AC10B	25	20	27	4.5	ø4.5	7	2.8	24.5	89	—	—	70	—
AC20B	30	24	33	5.5	ø5.5	12	3.2	29	132	—	118	114	—
AC25B	41	35	—	7	ø7	14	4	41	184	151	150	156	176
AC30B	41	35	—	7	ø7	14	4	41	187	154	153	159	179
AC40B	50	40	—	9	ø9	18	4	48	222	191	190	196	216
AC40B-06	50	40	—	9	ø9	18	4.6	48	224	193	192	198	218
AC50B	70	50	—	11	ø11	20	6.4	60	303	271	270	277	297
AC55B	70	50	—	11	ø11	20	6.4	60	316	285	284	290	310
AC60B	70	50	—	11	ø11	20	6.4	60	319	288	287	293	313

Note) For the AC20B only, the position of the pressure gauge is above the centre of the piping.



# Air Filter + Mist Separator + Regulator

# AC20C to AC40C

JIS Symbol

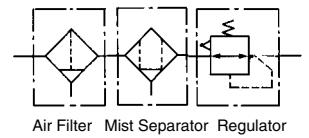

## How to Order

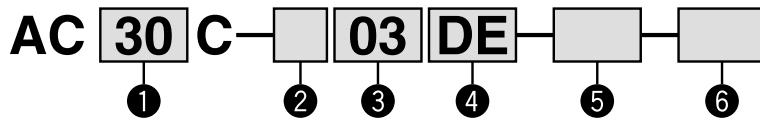

- Option / Semi-standard: Select one each for a to j.
  - Option / Attachment / Semi-standard symbol: Enter them alphanumerically.
- Example) AC30C-F03DE1-SV-16NR

	Symbol	Description	①					
			Body size					
			20	25	30	40		
②	Thread type	-	Rc	●	●	●	●	
		<b>N</b> <small>Note 1)</small>	NPT	●	●	●	●	
		<b>F</b> <small>Note 2)</small>	G	●	●	●	●	
+								
③	Port size	<b>01</b>	1/8	●	—	—	—	
		<b>02</b>	1/4	●	●	●	●	
		<b>03</b>	3/8	—	●	●	●	
		<b>04</b>	1/2	—	—	—	●	
		<b>06</b>	3/4	—	—	—	●	
+								
④	a	Float type auto drain	-	Without auto drain	●	●	●	●
			<b>C</b>	Float type auto drain (N.C.)	●	●	●	●
			<b>D</b>	Float type auto drain (N.O.)	—	●	●	●
	+							
	b	Pressure gauge	-	Without pressure gauge	●	●	●	●
			<b>E</b>	Square embedded type pressure gauge (with limit indicator)	●	●	●	●
			<b>G</b>	Round type pressure gauge (with limit indicator)	●	●	●	●
		Digital pressure switch	<b>E1</b>	Output: NPN output / Electrical entry: Wiring bottom entry	●	●	●	●
			<b>E2</b>	Output: NPN output / Electrical entry: Wiring top entry	●	●	●	●
			<b>E3</b>	Output: PNP output / Electrical entry: Wiring bottom entry	●	●	●	●
<b>E4</b>			Output: PNP output / Electrical entry: Wiring top entry	●	●	●	●	
+								
⑤	c	Pressure switch	-	Without attachment	●	●	●	●
			<b>S</b> <small>Note 4)</small>	Mounting position: AF+AFM+S+AR	●	●	●	●
		T-interface	<b>T</b> <small>Note 4)</small>	Mounting position: AF+AFM+T+AR	●	●	●	●
+								
d	3-port valve for residual pressure release	-	Without attachment	●	●	●	●	
		<b>V</b>	Mounting position: AF+AFM+AR+V	●	●	●	●	
		<b>V1</b> <small>Note 5)</small>	Mounting position: V+AF+AFM+AR□K	●	●	●	●	
+								
⑥	e	Set pressure	-	0.05 to 0.85 MPa set	●	●	●	●
			<b>1</b> <small>Note 6)</small>	0.02 to 0.2 MPa set	●	●	●	●
	+							
	f	Bowl	-	Polycarbonate bowl	●	●	●	●
			<b>2</b>	Metal bowl	●	●	●	●
			<b>6</b>	Nylon bowl	●	●	●	●
			<b>8</b>	Metal bowl with level gauge	—	●	●	●
			<b>C</b>	With bowl guard	●	—	—	—
			<b>6C</b>	Nylon bowl with bowl guard	●	—	—	—
	+							
	g	Filter Drain port <small>Note 7)</small>	-	With drain cock	●	●	●	●
<b>J</b> <small>Note 8)</small>			Drain guide 1/8	●	—	—	—	
			Drain guide 1/4	—	●	●	●	
<b>W</b> <small>Note 9)</small>			Drain cock with barb fitting: For ø6 x ø4 nylon tube	—	●	●	●	
+								
h	Exhaust mechanism	-	Relieving type	●	●	●	●	
		<b>N</b>	Non-relieving type	●	●	●	●	
+								
i	Flow direction	-	Flow direction: Left to right	●	●	●	●	
		<b>R</b>	Flow direction: Right to left	●	●	●	●	

# Air Combination *Series AC20C to AC40C*

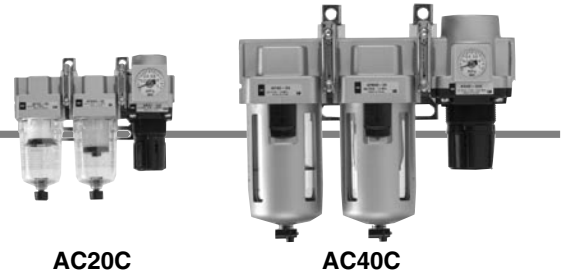

AC20C

AC40C

		Symbol	Description	①				
				Body size				
				20	25	30	40	
⑥	Semi-standard	j	Pressure unit	-	Name plate and pressure gauge in SI units: MPa			
				Z <sup>Note 10)</sup>	Name plate, caution plate for bowl, and pressure gauge in imperial units (PSI, °F)			
				ZA <sup>Note 11)</sup>	Digital pressure switch: With unit switching function			
				●	●	●	●	
				○ <sup>Note 12)</sup>	○ <sup>Note 12)</sup>	○ <sup>Note 12)</sup>	○ <sup>Note 12)</sup>	
				△ <sup>Note 13)</sup>	△ <sup>Note 13)</sup>	△ <sup>Note 13)</sup>	△ <sup>Note 13)</sup>	

- Note 1) Drain guide is NPT1/8 (applicable to the AC20C) and NPT1/4 (applicable to the AC30C to AC40C). The exhaust port for auto drain comes with  $\phi 3/8"$  One-touch fitting (applicable to the AC30C to AC40C).
- Note 2) Drain guide is G1/8 (applicable to the AC20C) and G1/4 (applicable to the AC30C to AC40C).
- Note 3) Option G is not assembled and is supplied loose at the time of shipment.
- Note 4) The bracket position varies depending on the T-interface or the pressure switch mounting.

- Note 5) In this configuration the regulator is equipped with a backflow mechanism. Additionally, for safety purposes, please check that the pressure on the outlet side is at atmospheric pressure after the pressure on the outlet side is exhausted, by using a pressure gauge, etc.
- Note 6) The only difference from the standard specifications is the adjusting spring for the regulator. It does not restrict the setting of 0.2 MPa or more. When the pressure gauge is attached, a 0.2 MPa pressure gauge will be fitted.
- Note 7) Float type auto drain: The combination between C or D is not available with the drain port options.
- Note 8) Without a valve function

- Note 9) Metal bowl: The combination of 2 or 8 cannot be selected with W.
- Note 10) For thread type: NPT. This product is for overseas use only according to the new Measurement Law. (The SI unit type is provided for use in Japan.) The digital pressure switch will be equipped with the unit switching function, setting to PSI initially.
- Note 11) For options: E1, E2, E3, E4. This product is for overseas use only according to the new Measurement Law. (The SI unit is provided for use in Japan.)
- Note 12) ○: For thread type: NPT only
- Note 13) △: Combination available for options: E1, E2, E3, E4.

## Standard Specifications

Model		AC20C	AC25C	AC30C	AC40C	AC40C-06
Component	Air filter	AF20	AF30	AF30	AF40	AF40-06
	Regulator	AFM20	AFM30	AFM30	AFM40	AFM40-06
	Lubricator	AR20	AR25	AR30	AR40	AR40-06
Port size		1/8, 1/4	1/4, 3/8	1/4, 3/8	1/4, 3/8, 1/2	3/4
Pressure gauge port size <sup>Note 1)</sup>		1/8			1/4	
Fluid		Air				
Ambient and fluid temperature <sup>Note 2)</sup>		-5 to 60°C (with no freezing)				
Proof pressure		1.5 MPa				
Maximum operating pressure		1.0 MPa				
Minimum operating pressure		0.05 MPa				
Set pressure range		0.05 to 0.85 MPa				
Relief pressure		Set pressure + 0.05 MPa <sup>Note 3)</sup> [at relief flow rate of 0.1 $\ell$ /min (ANR)]				
Nominal filtration rating		AF: 5 $\mu$ m, AFM: 0.3 $\mu$ m (95% filtered particle size)				
Outlet side oil mist concentration		Max. 1.0 mg/m <sup>3</sup> (ANR) ( $\approx$ 0.8 ppm) <sup>Note 4) Note 5)</sup>				
Rated flow ( $\ell$ /min (ANR)) <sup>Note 3)</sup>		200	450	Polycarbonate	1100	1100
Bowl material		450				
Bowl guard		Semi-standard	Standard			
Regulator construction		Relieving type				
Weight (kg)		0.74	0.88	0.95	1.76	1.83

- Note 1) Pressure gauge connection threads are not available for F.R.L. units with a square embedded type pressure gauge or with a digital pressure switch (the AC20C to AC40C).
- Note 2) -5 to 50°C for the products with the digital pressure switch.
- Note 3) Conditions: Mist separator inlet pressure: 0.7 MPa; The rated flow varies depending on the inlet pressure. Keep the air flow within the rated flow to prevent an outflow of lubricant to the outlet side.
- Note 4) When the compressor oil mist discharge concentration is 30 mg/m<sup>3</sup> (ANR).
- Note 5) Bowl O-ring and other O-rings are slightly lubricated.

# Series AC20C to AC40C

## Dimensions

### AC20C

### AC25C to AC40C-06

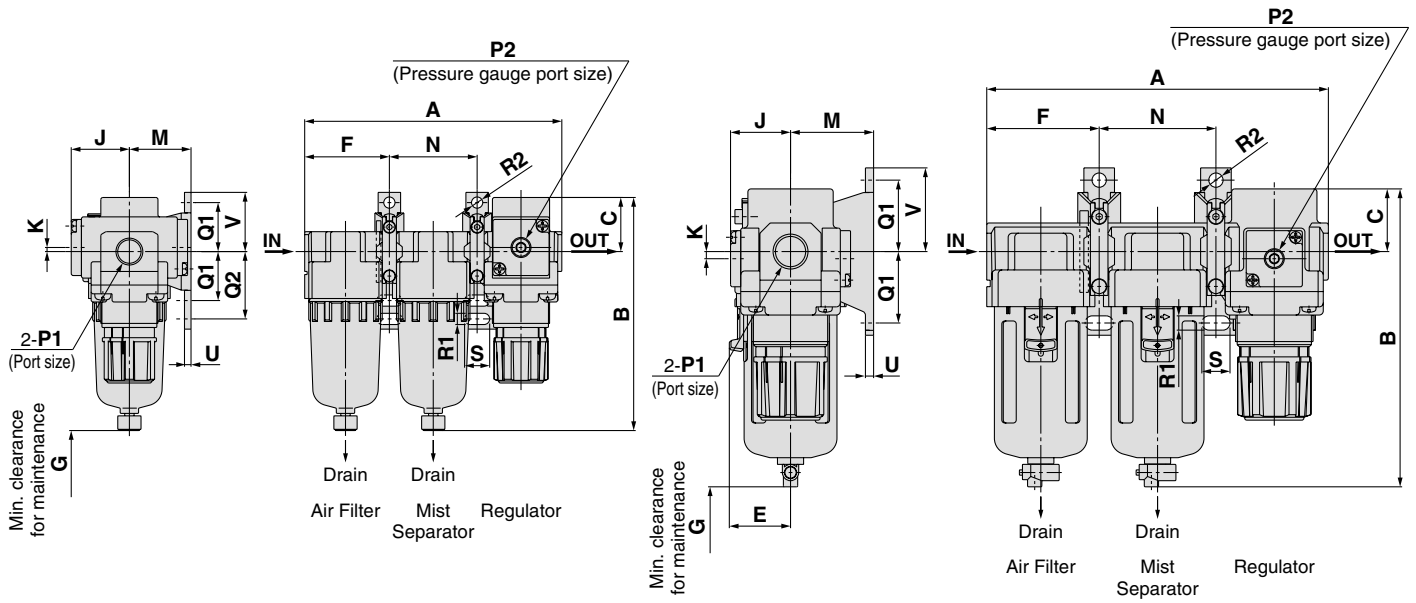

Applicable model	AC20C to AC40C-06		
Option	Square embedded type pressure gauge	Digital pressure switch	Round type pressure gauge
Dimensions			

Applicable model	AC20C				AC25C to AC40C-06				
Optional/Semi-standard specifications	With auto drain (N.C.)	Metal bowl	With drain guide	With auto drain (N.O./N.C.)	Metal bowl	Metal bowl with level gauge	With drain guide	Drain cock with barb fitting	
Dimensions									

Model	Standard specifications										Optional specifications					
	P1	P2	A	B	C	E	F	G	J	K	Square type pressure gauge		Digital pressure gauge		Round type pressure gauge	
AC20C	1/8, 1/4	1/8	126	114	26.5	—	41.5	45	28.5	2 <sup>Note)</sup>	□28	29.5	□27.8	40	ø37.5	65
AC25C	1/4, 3/8	1/8	167	143	28	30	55	50	27.5	0	□28	28.5	□27.8	39	ø37.5	64
AC30C	1/4, 3/8	1/8	167	146	31	30	55	50	29.5	3.5	□28	30.5	□27.8	41	ø37.5	66
AC40C	1/4, 3/8, 1/2	1/4	220	183	36	38	72.5	75	34	3.5	□28	35	□27.8	45	ø42.5	74
AC40C-06	3/4	1/4	235	185	36	38	77.5	75	34	3	□28	35	□27.8	45	ø42.5	74

Model	Optional specifications										Semi-standard specifications			
	Bracket mount										With auto drain	With barb fitting	With drain guide	Metal bowl
	M	N	Q1	Q2	R1	R2	S	U	V	B	B	B	B	B
AC20C	30	43	24	33	5.5	ø5.5	12	3.2	29	132	—	118	114	—
AC25C	41	57	35	—	7	ø7	14	4	41	184	151	150	156	176
AC30C	41	57	35	—	7	ø7	14	4	41	187	154	153	159	179
AC40C	50	75	40	—	9	ø9	18	4	48	222	191	190	196	216
AC40C-06	50	80	40	—	9	ø9	18	4.6	48	224	193	192	198	218

Note) For the AC20C only, the position of the pressure gauge is above the centre of the piping.



# Filter Regulator + Mist Separator

# AC20D to AC40D

JIS Symbol

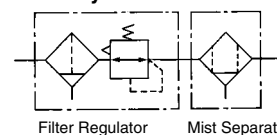

## How to Order

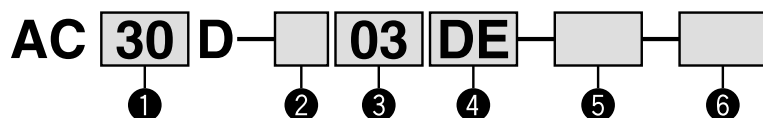

- Option / Semi-standard: Select one each for a to j.
  - Option / Attachment / Semi-standard symbol: Enter them alphanumerically.
- Example) AC30D-F03DE1-SV-16NR

		Symbol	Description	①			
				Body size			
				20	30	40	
②	Thread type	-	Rc	●	●	●	
		<b>N</b> <small>Note 1)</small>	NPT	●	●	●	
		<b>F</b> <small>Note 2)</small>	G	●	●	●	
		+					
③	Port size	<b>01</b>	1/8	●	—	—	
		<b>02</b>	1/4	●	●	●	
		<b>03</b>	3/8	—	●	●	
		<b>04</b>	1/2	—	—	●	
		<b>06</b>	3/4	—	—	●	
		+					
④	a	Float type auto drain	-	Without auto drain	●	●	●
			<b>C</b>	Float type auto drain (N.C.)	●	●	●
			<b>D</b>	Float type auto drain (N.O.)	—	●	●
			+				
	b	Pressure gauge	-	Without pressure gauge	●	●	●
			<b>E</b>	Square embedded type pressure gauge (with limit indicator)	●	●	●
			<b>G</b>	Round type pressure gauge (with limit indicator)	●	●	●
		Digital pressure switch	<b>E1</b>	Output: NPN output / Electrical entry: Wiring bottom entry	●	●	●
			<b>E2</b>	Output: NPN output / Electrical entry: Wiring top entry	●	●	●
			<b>E3</b>	Output: PNP output / Electrical entry: Wiring bottom entry	●	●	●
<b>E4</b>			Output: PNP output / Electrical entry: Wiring top entry	●	●	●	
		+					
⑤	c	Pressure switch	-	Without attachment	●	●	●
			<b>S</b> <small>Note 4)</small>	Mounting position: AW+S+AFM	●	●	●
			+				
d	3-port valve for residual pressure release	-	Without attachment	●	●	●	
		<b>V</b>	Mounting position: AW+AFM+V	●	●	●	
		<b>V1</b> <small>Note 5)</small>	Mounting position: V+AW□K+AFM	●	●	●	
		+					
⑥	e	Set pressure	-	0.05 to 0.85 MPa set	●	●	●
			<b>1</b> <small>Note 6)</small>	0.02 to 0.2 MPa set	●	●	●
			+				
	f	Bowl	-	Polycarbonate bowl	●	●	●
			<b>2</b>	Metal bowl	●	●	●
			<b>6</b>	Nylon bowl	●	●	●
			<b>8</b>	Metal bowl with level gauge	—	●	●
			<b>C</b>	With bowl guard	●	—	—
			<b>6C</b>	Nylon bowl with bowl guard	●	—	—
			+				
	g	Filter regulator Mist separator Drain port <small>Note 7)</small>	-	With drain cock	●	●	●
			<b>J</b> <small>Note 8)</small>	Drain guide 1/8	●	—	—
				Drain guide 1/4	—	●	●
<b>W</b> <small>Note 9)</small>			Drain cock with barb fitting: For ø6 x ø4 nylon tube	—	●	●	
		+					
h	Exhaust mechanism	-	Relieving type	●	●	●	
		<b>N</b>	Non-relieving type	●	●	●	
		+					
i	Flow direction	-	Flow direction: Left to right	●	●	●	
		<b>R</b>	Flow direction: Right to left	●	●	●	

# Air Combination *Series AC20D to AC40D*

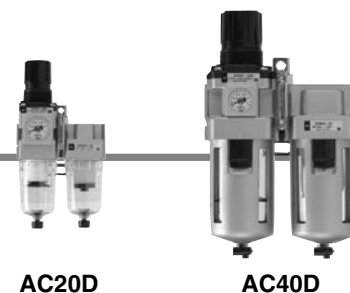

AC20D

AC40D

		Symbol	Description	①			
				Body size			
				20	30	40	
⑥	Semi-standard	j	-	Name plate and pressure gauge in SI units: MPa	●	●	●
			Z <sup>Note 10)</sup>	Name plate, caution plate for bowl, and pressure gauge in imperial units (PSI, °F)	○ <sup>Note 12)</sup>	○ <sup>Note 12)</sup>	○ <sup>Note 12)</sup>
			ZA <sup>Note 11)</sup>	Digital pressure switch: With unit switching function	△ <sup>Note 13)</sup>	△ <sup>Note 13)</sup>	△ <sup>Note 13)</sup>

Note 1) Drain guide is NPT1/8 (applicable to the AC20D) and NPT1/4 (applicable to the AC30D to AC40D). The exhaust port for auto drain comes with  $\phi 3/8"$  a One-touch fitting (applicable to the AC30D to AC40D).

Note 2) Drain guide is G1/8 (applicable to the AC20D) and G1/4 (applicable to the AC30D to AC40D).

Note 3) Option G is not assembled and is supplied loose at the time of shipment.

Note 4) The bracket position varies depending on the pressure switch mounting.

Note 5) In this configuration the regulator is equipped with a backflow mechanism. Additionally, for safety purposes, please check that the pressure on the outlet side is at atmospheric pressure after the pressure on the outlet side is exhausted, by using a pressure gauge, etc.

Note 6) The only difference from the standard specifications is the adjusting spring for the regulator. It does not restrict the setting of 0.2MPa or more. When the pressure gauge is attached, a 0.2 MPa pressure gauge will be fitted.

Note 7) Float type auto drain: The combination between C or D is not available with the drain port options.

Note 8) Without a valve function

Note 9) Metal bowl: The combination of 2 or 8 cannot be selected with W.

Note 10) For thread type: NPT. This product is for overseas use only according to the new Measurement Law. (The SI unit type is provided for use in Japan.) The digital pressure switch will be equipped with the unit switching function, setting to PSI initially.

Note 11) For options: E1, E2, E3, E4. This product is for overseas use only according to the new Measurement Law. (The SI unit is provided for use in Japan.)

Note 12) ○: For thread type: NPT only

Note 13) △: Combination available for options: E1, E2, E3, E4.

## Standard Specifications

Model		AC20D	AC30D	AC40D	AC40D-06
Component	Filter regulator	AW20	AW30	AW40	AW40-06
	Mist separator	AFM20	AFM30	AFM40	AFM40-06
Port size		1/8, 1/4	1/4, 3/8	1/4, 3/8, 1/2	3/4
Pressure gauge port size <sup>Note 1)</sup>		1/8		1/4	
Fluid		Air			
Ambient and fluid temperature <sup>Note 2)</sup>		-5 to 60°C (with no freezing)			
Proof pressure		1.5 MPa			
Maximum operating pressure		1.0 MPa			
Minimum operating pressure		0.05 MPa			
Set pressure range		0.05 to 0.85 MPa			
Relief pressure		Set pressure + 0.05 MPa <sup>Note 3)</sup> [at relief flow rate of 0.1 ℓ/min (ANR)]			
Nominal filtration rating		AF: 5 μm, AFM: 0.3 μm (95% filtered particle size)			
Rated flow (ℓ/min (ANR)) <sup>Note 3)</sup>		150	330	800	800
Outlet side oil mist concentration		Max. 1.0 mg/m <sup>3</sup> (ANR) (≈ 0.8 ppm) <sup>Note 4)</sup> <sup>Note 5)</sup>			
Bowl material		Polycarbonate			
Bowl guard		Semi-standard	Standard		
Regulator construction		Relieving type			
Weight (kg)		0.57	0.74	1.38	1.43

Note 1) Pressure gauge connection threads are not available for F.R.L. units with a square embedded type pressure gauge or with a digital pressure switch (the AC20D to AC40D).

Note 2) -5 to 50°C for the products with the digital pressure switch

Note 3) Conditions: Mist separator inlet pressure: 0.5 MPa; The rated flow varies depending on the inlet pressure keep the air flow within the rated flow to prevent an outflow of lubricant to the outlet side.

Note 4) When the compressor oil mist discharge concentration is 30 mg/m<sup>3</sup> (ANR).

Note 5) Bowl O-ring and other O-rings are slightly lubricated.

# Series AC20D to AC40D

## Dimensions

### AC20D

### AC30D to AC40D-06

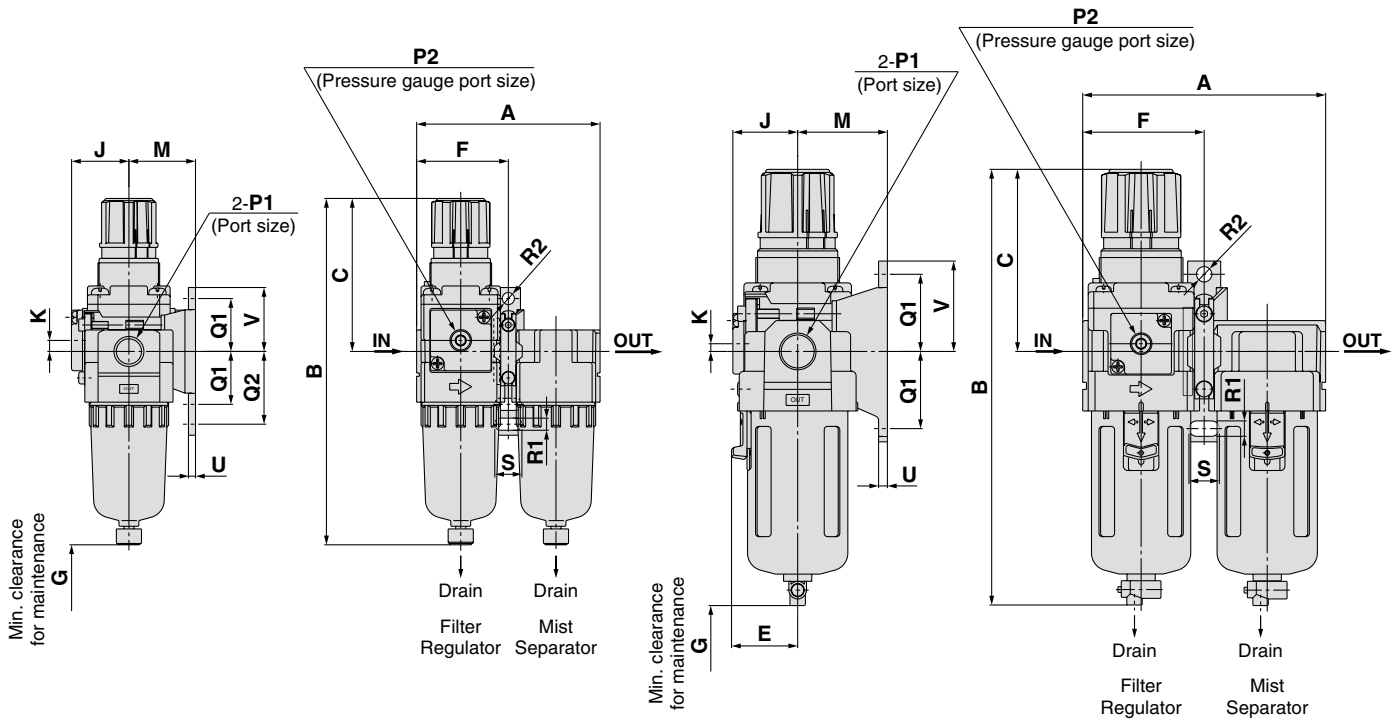

Applicable model	AC20D to AC40D-06		
Option	Square embedded type pressure gauge	Digital pressure switch	Round type pressure gauge
Dimensions			

Applicable model	AC20D			AC30D to AC40D-06				
Optional/Semi-standard specifications	With auto drain (N.C.)	Metal bowl	With drain guide	With auto drain (N.O./N.C.)	Metal bowl	Metal bowl with level gauge	With drain guide	Drain cock with barb fitting
Dimensions								

Model	Standard specifications										Optional specifications					
	P1	P2	A	B (Note)	C	E	F	G	J	K	Square type pressure gauge	Digital pressure gauge	Round type pressure gauge			
AC20D	1/8, 1/4	1/8	83	160	73	—	41.5	45	26	5	□28	27	□27.8	37.5	ø37.5	63
AC30D	1/4, 3/8	1/8	110	201	86	30	55	55	29.5	3.5	□28	30.5	□27.8	41	ø37.5	66
AC40D	1/4, 3/8, 1/2	1/4	145	239	92	38	72.5	80	37.5	1.5	□28	38.5	□27.8	49	ø42.5	76
AC40D-06	3/4	1/4	155	242	93	38	77.5	80	37.5	1.2	□28	38.5	□27.8	49	ø42.5	76

Model	Optional specifications								Semi-standard specifications				
	Bracket mount								With auto drain	With barb fitting	With drain guide	Metal bowl	Metal bowl with level gauge
	M	Q1	Q2	R1	R2	S	U	V	B	B	B	B	B
AC20D	30	24	33	5.5	ø5.5	12	3.2	29	177	—	164	160	—
AC30D	41	35	—	7	ø7	14	4	41	242	209	208	214	234
AC40D	50	40	—	9	ø9	18	4	48	278	247	246	252	272
AC40D-06	50	40	—	9	ø9	18	4.6	48	282	251	249	255	275

Note) The total length of B dimension is the length when the filter regulator handle is unlocked.

# Air Combination Series AC Options / Attachments

## Option / Attachment Part No.

Section	Type	Model	Part no.									
			For AC10	For AC20	For AC25	For AC30	For AC40	For AC40-06	For AC50	For AC55	For AC60	
			For AC10A	For AC20A	—	For AC30A	For AC40A	For AC40A-06	For AC50A	—	For AC60A	
			For AC10B	For AC20B	For AC25B	For AC30B	For AC40B	For AC40B-06	For AC50B	For AC55B	For AC60B	
			—	For AC20C	For AC25C	For AC30C	For AC40C	For AC40C-06	—	—	—	
			—	For AC20D	—	For AC30D	For AC40D	For AC40D-06	—	—	—	
Option	Round type	Standard	G27-10-R1	G36-10-□01			G46-10-□02					
		0.02 to 0.2 MPa set	G27-10-R1 (Note 3)	G36-2-□01			G46-2-□02					
	Square embedded type	Standard	—	GC3-10AS [GC3P-010AS (Pressure gauge cover only)]								
		0.02 to 0.2 MPa set	—	GC3-2AS [GC3P-010AS (Pressure gauge cover only)]								
	Digital pressure switch	NPN output/Wiring bottom entry	—	ISE35-N-25-MLA [ISE35-N-25-M (Switch body only)]								
		NPN output/Wiring top entry	—	ISE35-R-25-MLA [ISE35-R-25-M (Switch body only)]								
		PNP output/Wiring bottom entry	—	ISE35-N-65-MLA [ISE35-N-65-M (Switch body only)]								
		PNP output/Wiring top entry	—	ISE35-R-65-MLA [ISE35-R-65-M (Switch body only)]								
	Float type auto drain	N.O.	—	—	AD38			AD48				
		N.C.	AD17	AD27	AD37			AD47				
Attachment	Spacer	—	Y100	Y200	Y300		Y400	Y500	Y600			
	Check valve (Note 6) (Note 7)	—	—	AKM2000-□01 (□02)	AKM3000-(□01) □02		AKM4000-(□02) □03		—	—	—	—
	Pressure switch (Note 7)	—	—	IS1000M-20	IS1000M-30		IS1000M-40		IS1000M-50		IS1000M-60	
	T-interface (Note 6) (Note 7)	Y110-M5	Y210-□01 (□02)	Y310-(□01) □02		Y410-(□02) □03		Y510-(□02) □03		Y610-□03 (□04)		Y610-(□03) □04
	3-port valve for residual pressure release (Note 7)	—	VHS20-□01 □02	VHS30-□02 □03		VHS40-□03 □04		VHS40-□06		VHS50-□06 □10		—
	Piping adapter (Note 7)	E100-M5	□01 E200-□02 □03	□02 E300-□03 □04		□02 E400-□03 □04 □06		E500-□06		E600-□06 □10		
	Pressure switch with piping adapter (Note 7)	—	□01 IS1000E-20□02 □03	□02 IS1000E-30□03 □04		□02 IS1000E-40□03 □04 □06		—	—	—	—	—
	Cross spacer (Note 7)	Y14-M5	Y24-□01 □02	Y34-□01 □02		Y44-□02 □03		Y54-□03 □04		—	—	—

Note 1) □ in part numbers for a round pressure gauge indicates a type of connection thread. No indication is necessary for R; however, indicate N for NPT. Please contact SMC regarding the connection thread NPT and pressure gauge supply for PSI unit specifications.

Note 2) Includes one O-ring and 2 mounting screws

Note 3) Standard pressure gauge

Note 4) Lead wire with connector (2 m), adaptor, lock pin, O-ring (1 pc.), mounting screw (2 pcs.) are attached. [ ]: Switch body only. Also, regarding how to order the digital pressure switch, please refer to page 73.

Note 5) Minimum operating pressure: N.O. type-0.1 MPa; N.C. type-0.1 MPa (AD17/27) and 0.15 MPa (AD37/47). Please contact SMC for PSI and °F unit specifications.

Note 6) For F.R.L. units, port sizes not in ( ) are for standard application.

Note 7) Separate interfaces are required for modular unit.

## Check Valve (K): 1/8, 1/4, 3/8

A check valve with intermediate air release port can be easily installed to prevent a back flow of lubricant when redirecting the air flow and releasing the air on the outlet side of the regulator.

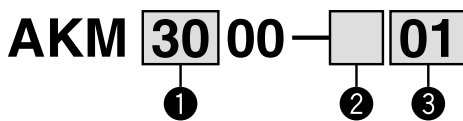

JIS Symbol

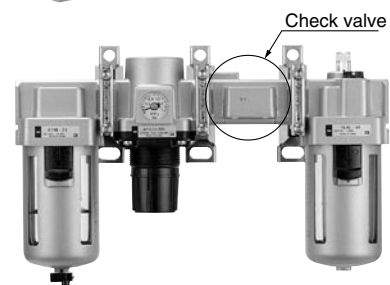
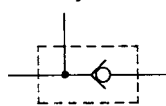

Symbol	Description	① Body size		
		20	30	40
② Thread type	- Rc	●	●	●
	N NPT	●	●	●
	F G	●	●	●
③ By-pass port size	01 1/8	●	—	—
	02 1/4	●	●	●
	03 3/8	—	●	●

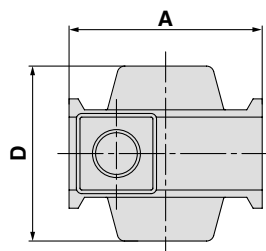

## Specifications

Model	Effective area (mm <sup>2</sup> )
AKM2000	28
AKM3000	55
AKM4000	111

Be sure to use above check valves when redirecting the air flow on the inlet side of the lubricator. Threads for the IN and OUT ports are not machined.

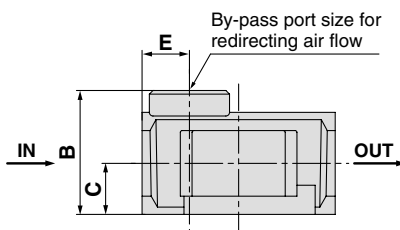

Model	By-pass port size	A	B	C	D	E	Applicable model
AKM2000	1/8, 1/4	40	28	11	40	11	AC20/AC20A
AKM3000	1/8, 1/4	53	34	14	48	13	AC25/AC25A AC30/AC30A
AKM4000	1/4, 3/8	70	42	18	54	15	AC40/AC40A (Note)

Note) A check valve cannot be mounted on the AC40□-06.

\* Refer to the attachment table above for standard by-pass port sizes applicable to the AC.

# Series AC

## Pressure Switch (S)

A compact integrated pressure switch can be easily installed and facilitates the pressure detection of the line.

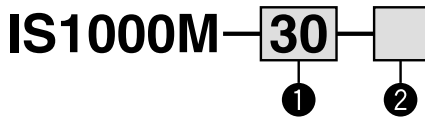

	Symbol	Description			① Body size				
		Lead wire length	Set pressure range	Pressure display	20	30	40	50	60
② Option	-	0.5 m	0.1 to 0.4 MPa	MPa	●	●	●	●	●
	P (Note)	0.5 m	0.1 to 0.4 MPa	MPa/PSI dual scale	●	●	●	●	●
	X202	0.5 m	0.1 to 0.6 MPa	MPa	●	●	●	●	●
	X202-P (Note)	0.5 m	0.1 to 0.6 MPa	MPa/PSI dual scale	●	●	●	●	●
	X201	3 m	0.1 to 0.4 MPa	MPa	●	●	●	●	●
	X201-P (Note)	3 m	0.1 to 0.4 MPa	MPa/PSI dual scale	●	●	●	●	●
	X215	3 m	0.1 to 0.6 MPa	MPa	●	●	●	●	●
X215-P (Note)	3 m	0.1 to 0.6 MPa	MPa/PSI dual scale	●	●	●	●	●	

Note) This product is for overseas use only according to the new Measurement Law. (The SI unit type is provided for use in Japan.)

### Specifications

Fluid	Air
Ambient and fluid temperature	-5 to 60°C (with no freezing)
Proof pressure	1.0 MPa
Maximum operating pressure	0.7 MPa
Set pressure range (when OFF)	0.1 to 0.4 MPa
Hysteresis	0.08 MPa or less

### Switch Characteristics

Contact point configuration	1a
Maximum contact point capacity	2 VA(AC), 2 W(DC)
Operating voltage: AC, DC	100 V or less
Maximum operating current	2 V to 24 VAC, DC : 50 mA 48 VAC, DC : 40 mA 100 VAC, DC : 20 mA

Note) For detailed specifications, please refer to Best Pneumatics, IS1000 Series.

## T-interface (T) M5, 1/8, 1/4, 3/8, 1/2

Using a T-interface facilitates the redirection of air flow.

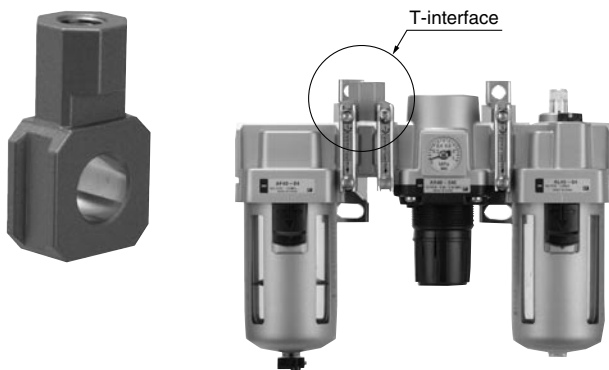

### Caution on Mounting

If a T-interface is used on the IN side of the lubricator, lubricant may be mixed. Use the AKM series check valve to avoid such a possibility.

### JIS Symbol

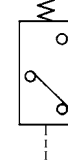

Pressure switch

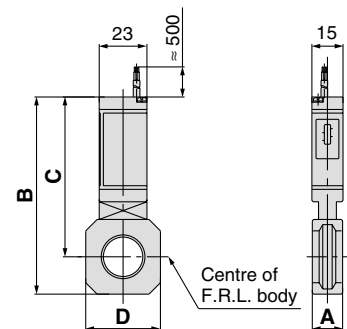

Model	A	B	C	D	Applicable model
IS1000M-20	11	76	66	28	AC20□
IS1000M-30	13	86	72	30	AC25□, AC30□
IS1000M-40	15	95	77	36	AC40□
IS1000M-50	17	99	79	44	AC40□-06
IS1000M-60	22	92.5	68.5	53	AC50□, AC55□, AC60□

Note) Separate spacers are required for modular unit.

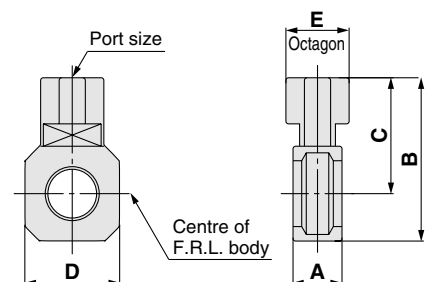

Model	Port size	A	B	C	D	E	Applicable model
Y110-M5	M5	11	19	12	14	8	AC10, AC10B
Y210-□01	1/8	15	42	32	28	19	AC20, AC20B, AC20C
Y210-□02	1/4						
Y310-□01	1/8	15	53	39	30	19	AC25, AC25B, AC25C, AC30, AC30B, AC30C
Y310-□02	1/4						
Y410-□02	1/4	19	62	44	36	24	AC40, AC40B, AC40C
Y410-□03	3/8						
Y510-□02	1/4	19	66	46	44	24	AC40-06, AC40B-06
Y510-□03	3/8						
Y610-□03	3/8	22	81	57	53	30	AC50, AC55, AC60, AC50B, AC55B, AC60B
Y610-□04	1/2						

Note 1) □ in model numbers indicates a thread type. No indication is necessary for Rc; however, indicate N for NPT, and F for G.

Note 2) Separate interfaces are required for modular unit.

\* Refer to the attachment table on page 22 for standard port sizes when using with the AC.

## Residual Pressure Relief 3 Port Valve (V)

With the use of a 3 port valve for residual pressure release, pressure left in the line can be easily exhausted.

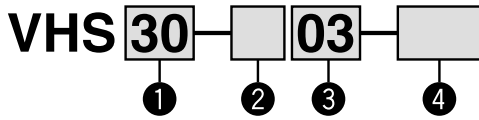

- Semi-standard: Select one each for **a** to **b**.
- Semi-standard symbol: Enter them alphanumerically.  
Example) VHS30-03-RZ

		Symbol	Description	
②	Thread type	-	Rc	
		<b>N</b> (Note)	NPT	
		<b>F</b> (Note)	G	
③	Port size	<b>+</b>		
		<b>01</b>	1/8	
		<b>02</b>	1/4	
		<b>03</b>	3/8	
		<b>04</b>	1/2	
		<b>06</b>	3/4	
④	a	Flow direction	-	Flow direction: Left to right
			<b>R</b>	Flow direction: Right to left
	b	Pressure unit	-	Name plate in imperial units: MPa
			<b>Z</b> (Note)	Name plate in imperial units: PSI

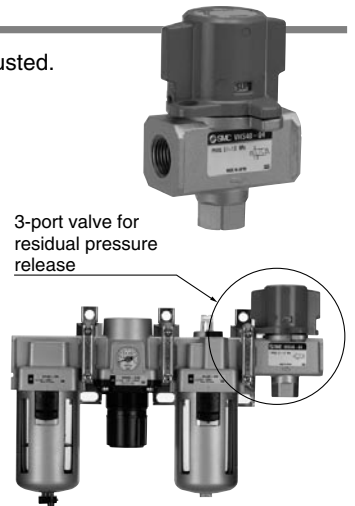
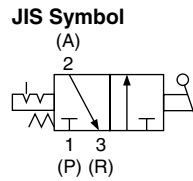

①				
Body size				
20	30	40	50	
●	●	●	●	
●	●	●	●	
●	●	●	●	
●	●	●	●	
●	●	●	●	
●	●	●	●	
●	●	●	●	

Note) For thread type: NPT only. This product is for overseas use only according to the new Measurement Law. (The SI unit type is provided for use in Japan.)

### Specifications

Model	Port size		Effective area (mm <sup>2</sup> ) ( ): Cv factor	
	IN,OUT	EXH	IN→OUT	OUT→EXH
VHS20	1/8	1/8	10 (0.54)	11 (0.60)
	1/4		14 (0.76)	16 (0.87)
VHS30	1/4	1/4	16 (0.87)	14 (0.76)
	3/8		31 (1.68)	29 (1.57)
VHS40	1/4	3/8	27 (1.46)	36 (1.95)
	3/8		38 (2.06)	40 (2.17)
	1/2		55 (2.98)	42 (2.28)
VHS40-06	3/4	1/2	77 (1.73)	49 (2.66)
VHS50	3/4	1/2	82 (4.44)	50 (2.71)
	1		125 (6.78)	53 (2.87)

Note) Use an air filter on the IN side for operating protection.

### Caution on Mounting

- If a stop valve or a silencer is connected to the exhaust port of the VHS20/30, the effective sectional area should be larger than the figure indicated in the following table, this is to prevent malfunction caused by back pressure. (This is not applicable to the VHS40 and VHS50)

Model	Effective sectional area (mm <sup>2</sup> )
VHS20	5
VHS30	5

### Cross Spacer M5, 1/8, 1/4, 3/8, 1/2

Piping is possible in all 4 directions.  
IN/OUT ports are not machined with threads.  
Please contact SMC if threaded (machined) ports are required.

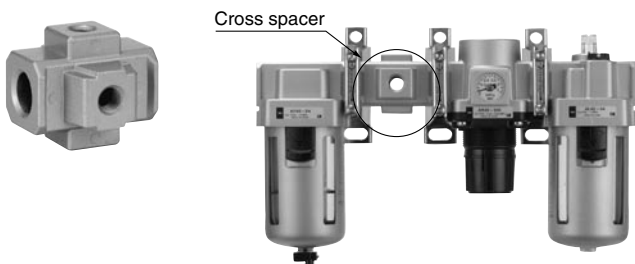

### Caution on Mounting

- When mounting a cross interface directly on the IN side of the lubricator, be sure to use the AKM series check valve between the lubricator and cross interface.
- Factory mounting of a cross interface on the AC model is available as a special order.

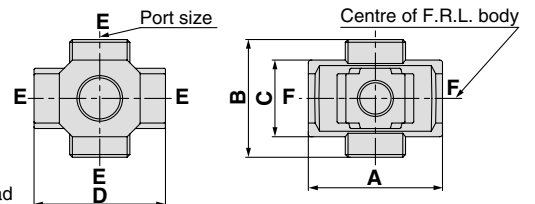

E: 4-Rc  
F: Without thread

Model	Port size	A	B	C	D	Applicable model
Y14-M5	M5	23	16	14	25	AC10□
Y24-□01	1/8	40	40	22	40	AC20□
Y24-□02	1/4					
Y34-□01	1/8	49	43	28	48	AC25□, AC30□
Y34-□02	1/4					
Y44-□02	1/4	60	48	36	54	AC40□
Y44-□03	3/8					
Y54-□03	3/8	72	62	40	62	AC40□-06
Y54-□04	1/2					

Note 1) □ in model numbers indicates a thread type. No indication is necessary for Rc; however, indicate N for NPT, and F for G.

Note 2) If threaded ports are required, they are available as a special order. Please contact SMC.

# Series AC

## Piping Adapter M5, 1/8, 1/4, 3/8, 1/2, 3/4, 1

A piping adapter allows installation/removal of the component without removing the piping and thus makes maintenance easier.

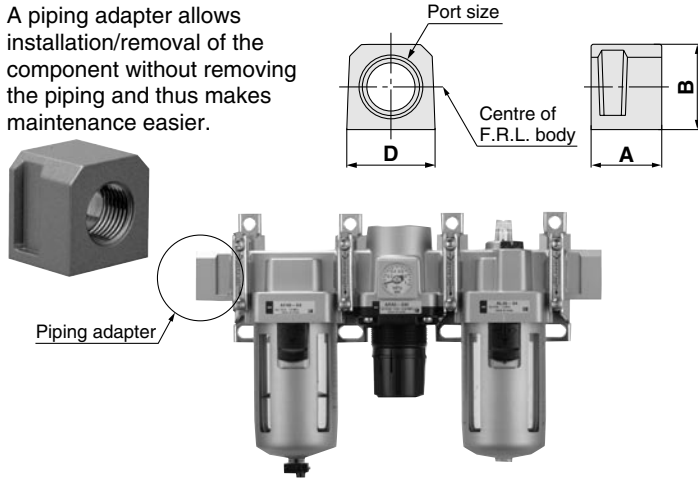

Model Note 1)	Port size	A	B	D	Applicable model
E100-M5	M5	10	14	14	AC10□, AW10, AF10, AR10, AL10
E200-□01	1/8	30	23.5	28	AC20□
E200-□02	1/4				AF20, AR20□, AW20□
E200-□03	3/8				AL20, AFM20, AFD20, AWM20, AWD20
E300-□02	1/4	32	30	30	AC25□, AC30□
E300-□03	3/8				AF30, AR30□, AW30□
E300-□04	1/2	32	36	36	AL30, AFM30, AFD30, AWM30, AWD30
E400-□02	1/4				AC40□
E400-□03	3/8				AF40, AR40□, AW40□
E400-□04	1/2				AL40, AFM40, AFD40
E400-□06	3/4				AWM40, AWD40
E500-□06	3/4	32	40	44	AC40□-06, AF40-06, AR40□-06, AW40□-06
E600-□06	3/4	35	48	53	AL40-06, AFM40-06, AFD40-06
					AC50, AC55, AC60, AC50A
E600-□10	1				AC60A, AC50B, AC55B
					AC60B, AF50, AF60, AR50□
					AR60□, AL50, AL60, AW60□

Note 1) □ in model numbers indicates a thread type. No indication is necessary for Rc; however, indicate N for NPT, and F for G.

Note 2) Separate interfaces are required for modular unit.

\* Factory mounting of piping adapters on the AC models are available as a special order.

## Pressure Switch with Piping Adapter

IS1000E-**30**□**03**□□

1 2 3 4

	Symbol	Description	① Body size			
			20	30	40	
② Thread type	-	Rc	●	●	●	
	N (Note)	NPT	●	●	●	
	F (Note)	G	●	●	●	
③ Port size	+ 01	1/8	●	—	—	
	02	1/4	●	●	—	
	03	3/8	●	●	●	
	04	1/2	—	●	●	
	06	3/4	—	—	●	
④ Accessory	Symbol	Lead wire length	Regulating pressure range	Pressure display	Mounting position	
	-	0.5 m	0.1 to 0.4 MPa	MPa	Right	● ● ●
	X250	0.5 m	0.1 to 0.4 MPa	MPa	Left	● ● ●
	P (Note)	0.5 m	0.1 to 0.4 MPa	MPa/PSI dual scale	Right	● ● ●
	X250-P (Note)	0.5 m	0.1 to 0.4 MPa	MPa/PSI dual scale	Left	● ● ●
	X202	0.5 m	0.1 to 0.6 MPa	MPa	Right	● ● ●
	X252	0.5 m	0.1 to 0.6 MPa	MPa	Left	● ● ●
	X202-P (Note)	0.5 m	0.1 to 0.6 MPa	MPa/PSI dual scale	Right	● ● ●
	X252-P (Note)	0.5 m	0.1 to 0.6 MPa	MPa/PSI dual scale	Left	● ● ●
	X201	3 m	0.1 to 0.4 MPa	MPa	Right	● ● ●
	X251	3 m	0.1 to 0.4 MPa	MPa	Left	● ● ●
	X201-P (Note)	3 m	0.1 to 0.4 MPa	MPa/PSI dual scale	Right	● ● ●
	X251-P (Note)	3 m	0.1 to 0.4 MPa	MPa/PSI dual scale	Left	● ● ●
	X215	3 m	0.1 to 0.6 MPa	MPa	Right	● ● ●
X253	3 m	0.1 to 0.6 MPa	MPa	Left	● ● ●	
X215-P (Note)	3 m	0.1 to 0.6 MPa	MPa/PSI dual scale	Right	● ● ●	
X253-P (Note)	3 m	0.1 to 0.6 MPa	MPa/PSI dual scale	Left	● ● ●	

Note) For thread type: NPT only. This product is for overseas use only according to the new Measurement Law. (The SI unit type is provided for use in Japan.)

### Specifications

Fluid	Air
Ambient and fluid temperature	-5 to 60°C (with no freezing)
Proof pressure	1.0 MPa
Maximum operating pressure	0.7 MPa
Set pressure range (when OFF)	0.1 to 0.4 MPa
Hysteresis	0.08 MPa or less

### Switch Characteristics

Contact point configuration	1a
Maximum contact point capacity	2VA(AC), 2W(DC)
Operating voltage: AC, DC	100V or less
Maximum operating current	12V to 24V AC, DC: 50 mA 48V AC, DC: 40 mA 100V AC, DC: 20 mA

Model Note 1)	Port size	A	B	C	D	E	Applicable model
IS1000E-20□01	1/8	30	68	57	28	16	AC20□
IS1000E-20□02	1/4						AR20□, AW20□
IS1000E-20□03	3/8						AWM20, AWD20
IS1000E-30□02	1/4	32	74.5	60.5	30	13	AC25□, AC30□
IS1000E-30□03	3/8						AR25□, AR30□, AW30□
IS1000E-30□04	1/2	32	80.5	62.5	37	12.5	AWM30, AWD30
IS1000E-40□02	1/4						Note 2)
IS1000E-40□03	3/8						AC40□
IS1000E-40□04	1/2						AR40□, AW40□
IS1000E-40□06	3/4						AWM40, AWD40

Note 1) □ in the model numbers indicates a thread type. No indication is necessary for Rc; however, indicate N for NPT, and F for G.

Note 2) Cannot be mounted on the AC40□-06 and AW40□-06.

Note 3) Separate interfaces are required for modular unit.

\* The pressure switch on the AC40□-06 and above and the AW40□-06 can be mounted by screwing IS1000-01 into the piping adapter E500-□06-X501 or E600-□06-X501 to E600-□10-X501 (with top-face thread Rc 1/8). Products with a premounted switch are available as a special order. Please contact SMC regarding their availability.

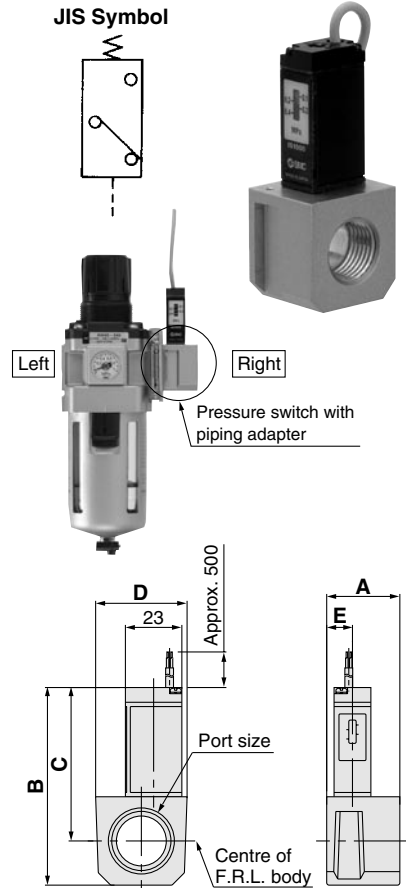

# Series AC Spacers / Brackets Accessories

## Spacer

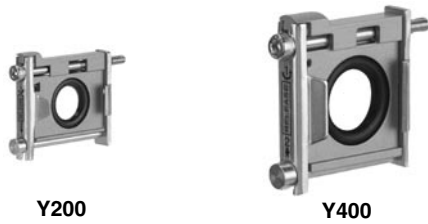

Y200

Y400

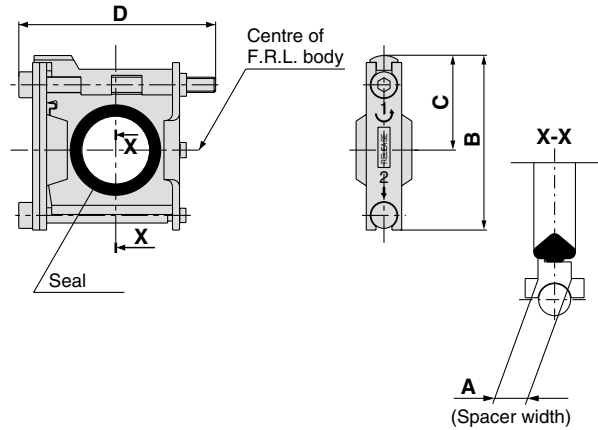

Model	A	B	C	D	Applicable model
Y100	6	27	15	33	AC10, AC10A, AC10B
Y200	3	35.5	18.5	48	AC20□
Y300	4	47	26	59	AC25□, AC30□
Y400	5	57	31	65	AC40□
Y500	5	61	33	75	AC40□-06
Y600	6	75.5	41	86	AC50, AC55, AC60 AC50A, AC60A AC50B, AC55B, AC60B

### Replacement Parts

Description	Material	Part no.					
		Y100	Y200	Y300	Y400	Y500	Y600
Seal	HNBR <sup>Note 2)</sup>	Y100P-060AS <sup>Note 1)</sup>	Y200P-061S	Y300P-060S	Y400P-060S	Y500P-060S	Y600P-060S

Note 1) Assembly includes 2 O-rings

Note 2) NBR is used for Y100T spacer because there is no direct contact with fluid.

## Spacer with Bracket



Y200T

Y400T

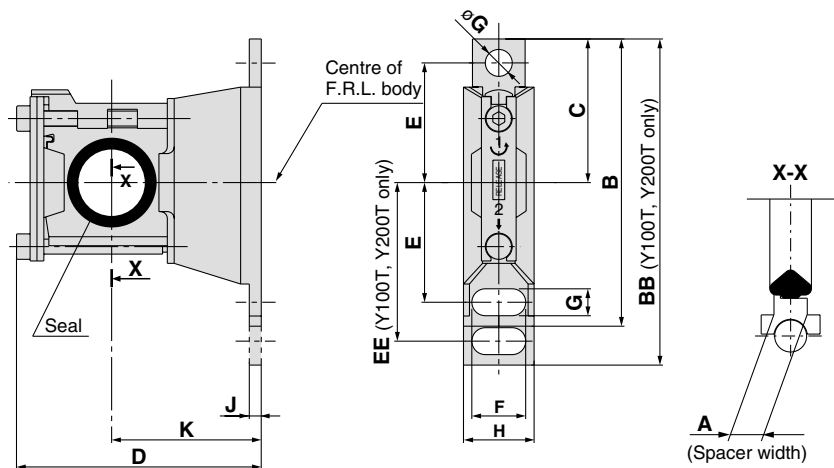

Model	A	B	BB	C	D	E	EE	F	G	øG	H	J	K	Applicable model
Y100T	6	—	56	24.5	40.5	20	27	6.8	4.5	4.5	14	2.8	25	AC10□
Y200T	3	—	67	29	53	24	33	12	5.5	5.5	19	3.2	30	AC20□
Y300T	4	82	—	41	68	35	—	14	7	7	21	4	41	AC25□, AC30□
Y400T	5	96	—	48	81.5	40	—	18	9	9	26	4	50	AC40□
Y500T	5	96	—	48	86	40	—	18	9	9	27	4.6	50	AC40□-06
Y600T	6	120	—	60	112	50	—	20	11	11	31	6.4	70	AC50, AC55, AC60, AC50A, AC60A, AC50B AC55B, AC60B

### Replacement Parts

Description	Material	Part no.					
		Y100T	Y200T	Y300T	Y400T	Y500T	Y600T
Seal	HNBR <sup>Note 2)</sup>	Y100P-060AS <sup>Note 1)</sup>	Y200P-061S	Y300P-060S	Y400P-060S	Y500P-060S	Y600P-060S

Note 1) Assembly includes with 2 O-rings

Note 2) NBR is used for Y100T spacer because there is no direct contact with fluid.

# Series AC

## Mounting Position for Spacer with Bracket

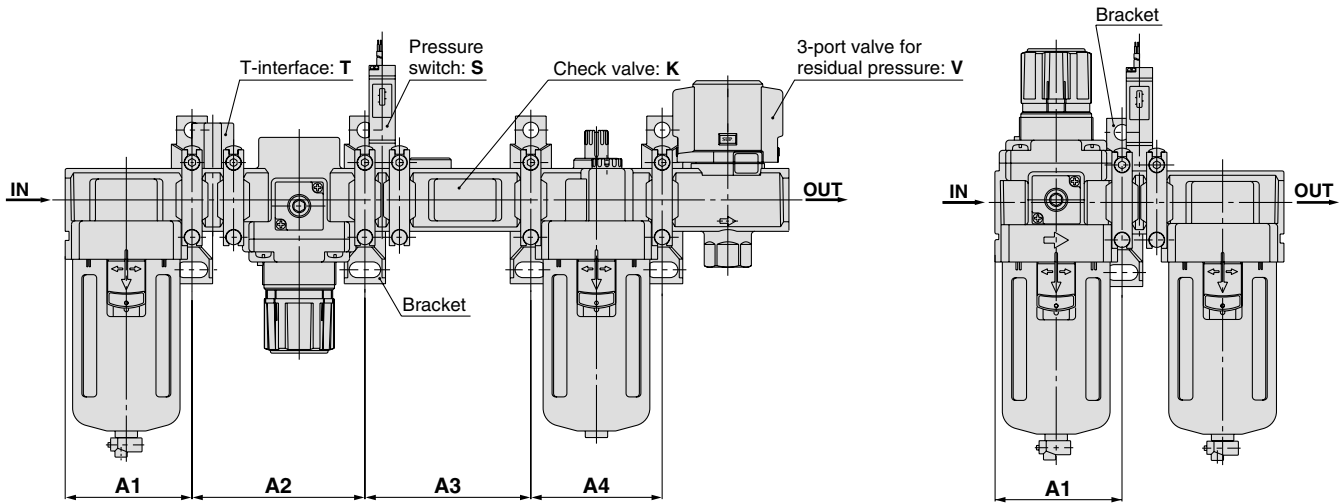

Attachment Model	K			S		T		V			KS			KT			KV				KST		
	A1	A2	A3	A1	A2	A1	A2	A1	A2	A3	A1	A2	A3	A1	A2	A3	A1	A2	A3	A4	A1	A2	A3
AC10	—	—	—	—	—	—	28	48	—	—	—	—	—	—	—	—	—	—	—	—	—	—	—
AC20	41.5	43	43	41.5	43	41.5	61	41.5	43	43	41.5	43	57	41.5	61	43	41.5	43	43	43	41.5	61	57
AC25	55	57	57	55	57	55	76	55	57	57	55	57	74	55	76	57	55	57	57	57	55	76	74
AC30	55	57	57	55	57	55	76	55	57	57	55	57	74	55	76	57	55	57	57	57	55	76	74
AC40	72.5	75	75	72.5	75	72.5	99	72.5	75	75	72.5	75	95	72.5	99	75	72.5	75	75	75	72.5	99	95
AC40-06	—	—	—	77.5	80	77.5	104	77.5	80	80	—	—	—	—	—	—	—	—	—	—	—	—	—
AC50	—	—	—	93	96	93	124	93	96	96	—	—	—	—	—	—	—	—	—	—	—	—	—
AC55	—	—	—	98	96	98	124	—	—	—	—	—	—	—	—	—	—	—	—	—	—	—	—
AC60	—	—	—	98	101	98	129	—	—	—	—	—	—	—	—	—	—	—	—	—	—	—	—

Attachment Model	KSV				KTV				KSTV				ST		SV			STV			TV		
	A1	A2	A3	A4	A1	A2	A3	A4	A1	A2	A3	A4	A1	A2	A1	A2	A3	A1	A2	A3	A1	A2	A3
AC10	—	—	—	—	—	—	—	—	—	—	—	—	—	—	—	—	—	—	—	—	—	—	—
AC20	41.5	43	57	43	41.5	61	43	43	41.5	61	57	43	41.5	61	41.5	43	57	41.5	61	57	41.5	61	43
AC25	55	57	74	57	55	76	57	57	55	76	74	57	55	76	55	57	74	55	76	74	55	76	57
AC30	55	57	74	57	55	76	57	57	55	76	74	57	55	76	55	57	74	55	76	74	55	76	57
AC40	72.5	75	95	75	72.5	99	75	75	72.5	99	95	75	72.5	99	72.5	99	72.5	75	95	72.5	99	95	72.5
AC40-06	—	—	—	—	—	—	—	—	—	—	—	—	—	77.5	104	77.5	80	102	77.5	104	102	77.5	104
AC50	—	—	—	—	—	—	—	—	—	—	—	—	—	93	124	93	96	124	93	124	124	93	124
AC55	—	—	—	—	—	—	—	—	—	—	—	—	—	98	124	—	—	—	—	—	—	—	—
AC60	—	—	—	—	—	—	—	—	—	—	—	—	—	98	129	—	—	—	—	—	—	—	—

Attachment Model	K		S		V		KS		KV			KSV			SV	
	A1	A2	A1	A2	A1	A2	A1	A2	A1	A2	A3	A1	A2	A3	A1	A2
AC20A	41.5	43	41.5	43	41.5	43	41.5	57	41.5	43	43	41.5	57	43	41.5	57
AC30A	55	57	55	57	55	74	55	74	55	57	55	74	57	55	74	
AC40A	72.5	75	72.5	75	72.5	95	72.5	95	72.5	75	75	72.5	95	75	72.5	95
AC40A-06	—	—	77.5	77.5	80	—	—	—	—	—	—	—	—	—	77.5	102



Attachment Model	S		T		V		V1		SV		SV1		TV		TV1	
	A1	A1	A1	A2	A1	A2	A1	A2	A1	A2	A1	A2	A1	A2	A1	A2
AC10B	—	28	—	—	—	—	—	—	—	—	—	—	—	—	—	—
AC20B	41.5	41.5	41.5	43	41.5	43	41.5	57	41.5	43	41.5	61	41.5	43		
AC25B	55	55	55	57	55	57	55	74	55	57	55	76	55	57		
AC30B	55	55	55	57	55	57	55	74	55	57	55	76	55	57		
AC40B	72.5	72.5	72.5	75	72.5	75	72.5	95	72.5	75	72.5	99	72.5	75		
AC40B-06	77.5	77.5	77.5	80	77.5	80	77.5	102	77.5	80	77.5	104	77.5	80		
AC50B	93	93	93	96	93	96	93	124	93	96	93	124	93	96		
AC55B	98	98	—	—	—	—	—	—	—	—	—	—	—	—		
AC60B	98	98	—	—	—	—	—	—	—	—	—	—	—	—		

Attachment Model	S		T		V			V1			SV			SV1			TV			TV1		
	A1	A2	A1	A2	A1	A2	A3	A1	A2	A3	A1	A2	A3	A1	A2	A3	A1	A2	A3	A1	A2	A3
AC20C	41.5	43	41.5	43	41.5	43	43	41.5	43	43	41.5	43	57	41.5	43	43	41.5	43	61	41.5	43	43
AC25C	55	57	55	57	55	57	57	55	57	57	55	57	74	55	57	57	55	57	76	55	57	57
AC30C	55	57	55	57	55	57	57	55	57	57	55	57	74	55	57	57	55	57	76	55	57	57
AC40C	72.5	75	72.5	75	72.5	75	75	72.5	75	75	72.5	75	95	72.5	75	75	72.5	75	99	72.5	75	75
AC40C-06	77.5	80	77.5	80	77.5	80	80	77.5	80	80	77.5	80	102	77.5	80	80	77.5	80	104	77.5	80	80

Attachment Model	S		V		V1		SV		SV1	
	A1	A1	A2	A1	A2	A1	A2	A1	A2	A1
AC20D	41.5	41.5	43	41.5	43	41.5	57	41.5	43	
AC30D	55	55	57	55	57	55	74	55	57	
AC40D	72.5	72.5	75	72.5	75	72.5	95	72.5	75	
AC40D-06	77.5	77.5	80	77.5	80	77.5	102	77.5	80	

A1: Dimensions from the end of the IN side to the centre of the mounting hole for the first bracket.  
A2: Mounting hole pitch between the first and the second bracket.  
A3: Mounting hole pitch between the second and the third bracket.  
A4: Mounting hole pitch between the third and the fourth bracket.

# Modular Type Air Filters *Series AF*

Air Filter Series AF	Model	Port size	Filtration ( $\mu\text{m}$ )	Option
 <p data-bbox="165 898 448 927">Page 29 through to 34</p>	<b>AF10</b>	M5	5	Bracket  Float type auto drain
	<b>AF20</b>	1/8, 1/4		
	<b>AF30</b>	1/4, 3/8		
	<b>AF40</b>	1/4, 3/8, 1/2		
	<b>AF40-06</b>	3/4		
	<b>AF50</b>	3/4, 1		
	<b>AF60</b>	1		
 <p data-bbox="165 1229 448 1258">Page 35 through to 38</p>	<b>AFM20</b>	1/8, 1/4	0.3	Bracket  Float type auto drain
	<b>AFM30</b>	1/4, 3/8		
	<b>AFM40</b>	1/4, 3/8, 1/2		
	<b>AFM40-06</b>	3/4		
 <p data-bbox="165 1565 448 1594">Page 35 through to 38</p>	<b>AFD20</b>	1/8, 1/4	0.01	Bracket  Float type auto drain
	<b>AFD30</b>	1/4, 3/8		
	<b>AFD40</b>	1/4, 3/8, 1/2		
	<b>AFD40-06</b>	3/4		

# Air Filter

# AF10 to AF60

JIS Symbol  
Air Filter

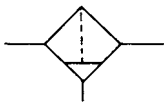

JIS Symbol  
Air Filter with Auto Drain

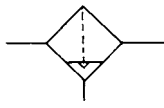

## How to Order

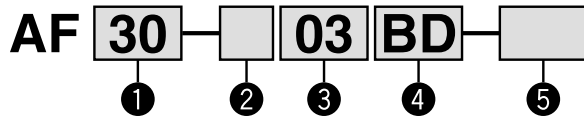

- Option / Semi-standard: Select one each for **a** to **f**.
- Option / Semi-standard symbol: When more than one specification is required, indicate in ascending alphanumeric order.  
Example) AF30-03BD-2R

	Symbol	Description	①									
			Body size									
			10	20	30	40	50	60				
②	Thread type	-	Metric thread (M5)									
		Rc	●	—	—	—	—	—				
		N <small>Note 1)</small>	—	●	●	●	●	●				
		F <small>Note 2)</small>	—	●	●	●	●	●				
③	Port size	M5	●	—	—	—	—	—				
		01	—	●	—	—	—	—				
		02	—	●	●	—	—	—				
		03	—	—	●	●	—	—				
		04	—	—	—	●	—	—				
		06	—	—	—	●	●	—				
		10	—	—	—	—	●	●				
④	Option	a	Mounting	-	Without mounting option	●	●	●	●	●	●	
				B <small>Note 4)</small>	With bracket	—	●	●	●	●	●	
④	Option	b	Float type auto drain	-	Without auto drain	●	●	●	●	●	●	
				C	Float type auto drain (N.C.)	●	●	●	●	●	●	
				D	Float type auto drain (N.O.)	—	—	●	●	●	●	
⑤	Semi-standard	c	Bowl	-	Polycarbonate bowl	●	●	●	●	●	●	
				2	Metal bowl	●	●	●	●	●	●	
				6	Nylon bowl	●	●	●	●	●	●	
				8	Metal bowl with level gauge	—	—	●	●	●	●	
				C	With bowl guard	—	●	—	—	—	—	
				6C	Nylon bowl with bowl guard	—	●	—	—	—	—	
	⑤	Semi-standard	d	Drain port <small>Note 5)</small>	-	With drain cock	●	●	●	●	●	●
					J <small>Note 6)</small>	Drain guide 1/8	—	●	—	—	—	—
						Drain guide 1/4	—	—	●	●	●	●
					W <small>Note 7)</small>	Drain cock with barb fitting: For ø6 x ø4 nylon tube	—	—	●	●	●	●
	⑤	Semi-standard	e	Flow direction	-	Flow direction: Left to right	●	●	●	●	●	
R					Flow direction: Right to left	●	●	●	●	●		
⑤	Semi-standard	f	Pressure unit	-	Name plate and caution plate for bowl in SI units: MPa	●	●	●	●	●		
				Z <small>Note 8)</small>	Name plate and caution plate for bowl in imperial units (PSI, °F)	○ <small>Note 9)</small>	○ <small>Note 9)</small>	○ <small>Note 9)</small>	○ <small>Note 9)</small>	○ <small>Note 9)</small>	○ <small>Note 9)</small>	

Note 1) Drain guide is NPT1/8 (applicable to the AF20) and NPT1/4 (applicable to the AF30 and AF60). The exhaust port for auto drain comes with a ø3/8" One-touch fitting (applicable to the AF30 to AF40).

Note 2) Drain guide is G1/8 (applicable to the AF20) and G1/4 (applicable to the AF30 to AF60).

Note 3) Option B is not assembled and is supplied loose at the time of shipment.

Note 4) Includes 2 mounting screws

Note 5) Float type auto drain: The combination between C and D is not available.

Note 6) Without a valve function

Note 7) Metal bowl: The combination of 2 or 8 cannot be selected with W.

Note 8) For thread type: M5 and NPT. This product is for overseas use only according to the new Measurement Law. (The SI unit type is provided for use in Japan.)

Note 9) ○: For thread type: M5 and NPT only

## Standard Specifications

Model	AF10	AF20	AF30	AF40	AF40-60	AF50	AF60
Port size	M5	1/8, 1/4	1/4, 3/8	1/4, 3/8, 1/2	3/4	3/4, 1	1
Fluid	Air						
Ambient and fluid temperature	-5 to 60°C (with no freezing)						
Proof pressure	1.5 MPa						
Maximum operating pressure	1.0 MPa						
Nominal filtration rating	5 μm						
Drain capacity (cm <sup>3</sup> )	2.5	8	25	45			
Bowl material	Polycarbonate						
Bowl guard	—	Semi-standard	Standard				
Weight (kg)	0.06	0.18	0.22	0.45	0.49	0.99	1.05

## Option / Part No.

Option	Model	AF10	AF20	AF30	AF40	AF40-60	AF50	AF60
Bracket assembly <sup>Note 1)</sup>		—	AF20P-050AS	AF30P-050AS	AF40P-050AS	AF40P-070AS	AF50P-050AS	AF50P-050AS
Float type auto drain <sup>Note 2)</sup>	N.O.	—	—	AD38	AD48			
	N.C.	AD17	AD27	AD37	AD47			

Note 1) Assembly includes a bracket and 2 mounting screws

Note 2) Minimum operating pressure: N.O. type-0.1 MPa; N.C. type-0.1 MPa (AD17/277) and 0.15 MPa (AD37/47). Please contact SMC for PSI and °F unit specifications.

## Flow Characteristics (Representative values)

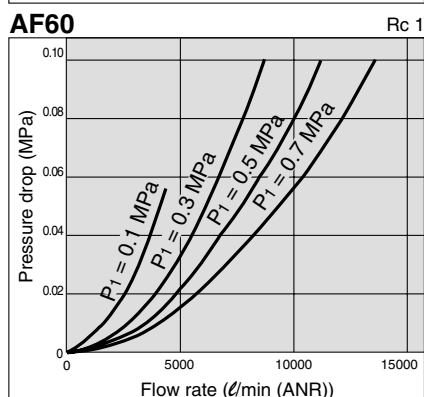
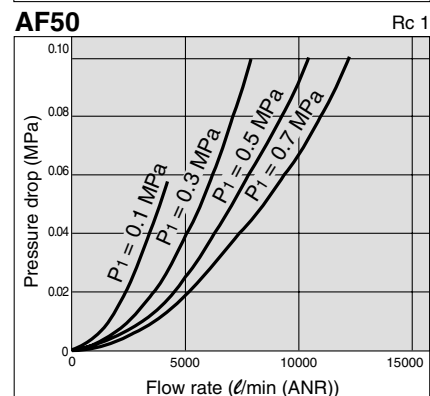
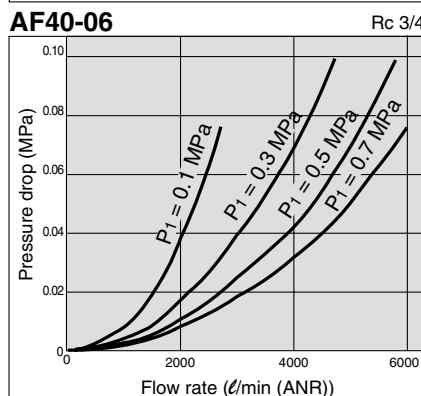
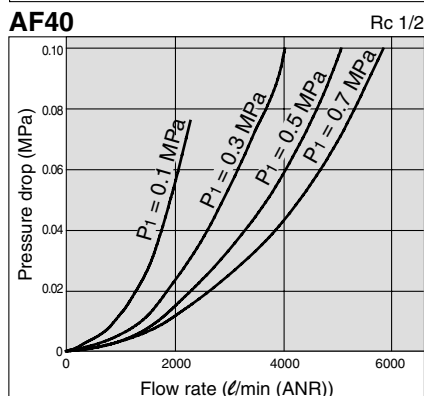
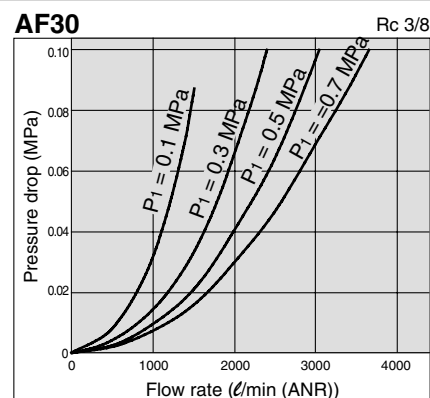
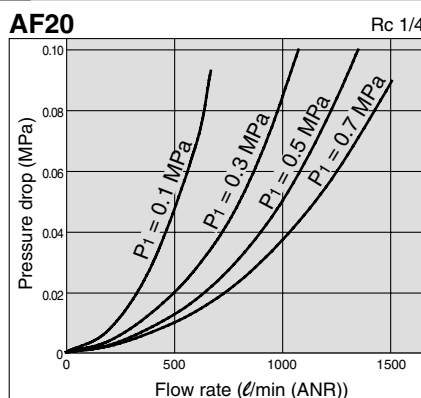
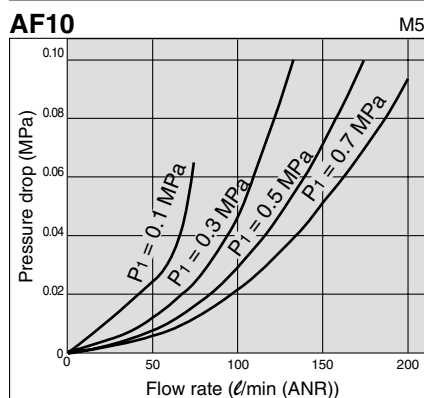

## ⚠ Specific Product Precautions

Be sure to read this before handling. Refer to "Precautions for Handling Pneumatic Devices" (M-03-E3A) for Safety Instructions and F.R.L. Unit Precautions.

### Mounting and Adjustment

## ⚠ Warning

1. Replace the element every 2 years or when the pressure drop becomes 0.1 MPa, whichever comes first, to prevent damage to the element.

# Series AF10 to AF60

## Working Principle: Float Type Auto Drain

### N.O. type: AD38, AD48

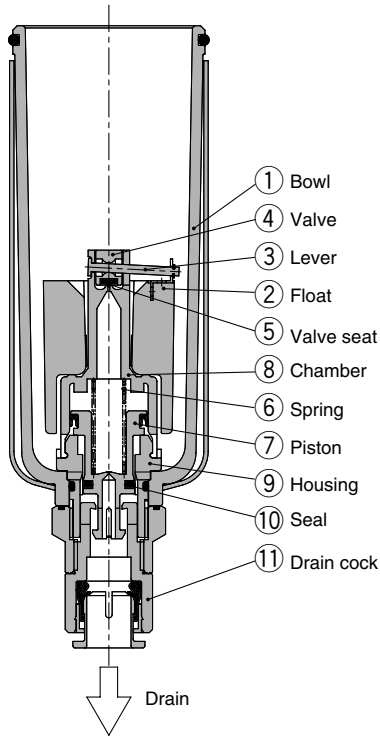

### N.C. type: AD37, AD47

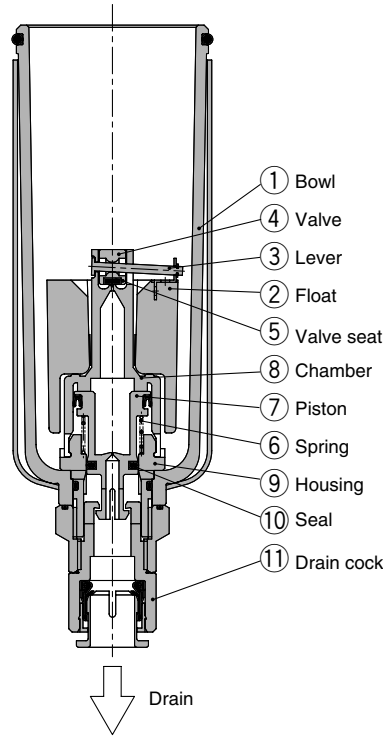

### Compact auto drain N.C. type: AD17, AD27

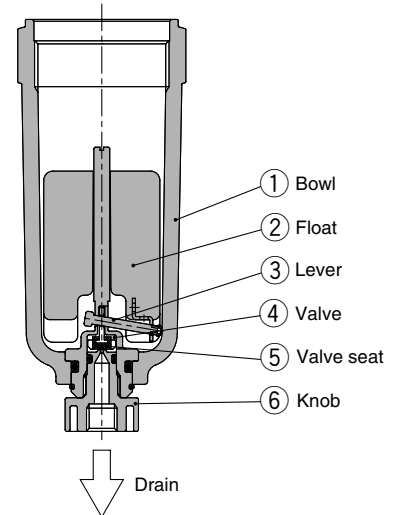

- **When pressure inside the bowl is released:**

When pressure is released from the bowl ①, piston ⑦ is lowered by spring ⑥.

The sealing action of seal ⑩ is interrupted, and the outside air flows inside the bowl ①, through housing hole ⑨ and drain cock ⑪.

Therefore, if there is an accumulation of condensate in the bowl ①, it will drain out through the drain cock.

- **When pressure is applied inside the bowl:**

When pressure exceeds 0.1 MPa, the force of piston ⑦ surpasses the force of spring ⑥, and the piston goes up.

This pushes seal ⑩ up so that it creates a seal and the inside of the bowl ①, is shut off from the outside air.

If there is no accumulation of condensate in the bowl ①, at this time float ② will be pulled down by its own weight, causing valve ④, which is connected to lever ③, to seal valve seat ⑤.

- **When there is an accumulation of condensate in the bowl:**

Float ② rises due to its own buoyancy and pushes open the seal created by the valve seat ⑤.

This allows the pressure inside the bowl ①, to enter the chamber ⑧. The result is that the combined pressure inside chamber ⑧ and the force of the spring ⑥, lowers the piston ⑦.

This causes the sealing action of seal ⑩ to be interrupted, and the accumulated condensate in the bowl ①, drains out through the drain cock ⑪.

Turning drain cock ⑪ manually counterclockwise lowers piston ⑦, which pushes open the seal created by seal ⑩, thus allowing the condensate to drain out.

- **When pressure inside the bowl is released:**

Even when pressure inside the bowl ①, is released, spring ⑥ keeps piston ⑦ in its upward position.

This keeps the seal created by the seal ⑩, in place, thus shutting the outside air from inside the bowl ①.

Therefore, even if there should be some condensate accumulation inside the bowl ①, it will not drain out.

- **When pressure is applied inside the bowl:**

Even when pressure is applied inside the bowl ①, the combined force of spring ⑥ and the pressure inside the bowl ①, keeps piston ⑦ in its upward position.

This maintains the seal created by the seal ⑩, in place, thus shutting the outside air from inside the bowl ①.

If there is no accumulation of condensate in the bowl ①, at this time float ② will be pulled down by its own weight, causing valve ④, which is connected to lever ③, to seal valve seat ⑤.

- **When there is an accumulation of condensate in the bowl:**

Float ② rises due to its own buoyancy and pushes open the seal created by the valve seat ⑤. Pressure passes from the bowl ① to chamber ⑧.

The result is that the pressure inside chamber ⑧ surpasses the force of the spring ⑥, and pushes piston ⑦ downwards.

This causes the sealing action of seal ⑩ to be interrupted and the accumulated condensate in the bowl ①, drains out through the drain cock ⑪.

Turning drain cock ⑪ manually counterclockwise lowers piston ⑦, which pushes open the seal created by seal ⑩, thus allowing the condensate to drain out.

- **When pressure inside the bowl is released:**

Even when pressure inside the bowl ①, is released, the weight of the float ② causes valve ④, which is connected to lever ③, to seal valve seat ⑤. As a result, the inside of the bowl ①, is shut off from the outside air.

Therefore, even if there is an accumulation of condensate in the bowl ①, it will not drain out.

- **When pressure is applied inside the bowl:**

Even when pressure is applied inside the bowl ①, the weight of the float ②, and the differential pressure that is applied to valve ④ causes valve ④ to seal valve seat ⑤, and the outside air is shut off from the inside of the bowl ①.

- **When there is an accumulation of condensate in the bowl**

Float ② rises due to its own buoyancy and the seal at valve seat ⑤ is interrupted.

The condensate inside the bowl ① drains out through the knob, ⑥.

Turning knob ⑥ manually counterclockwise lowers it and causes the sealing action of valve seat ⑤ to be interrupted, thus allowing the condensate to drain out.

## Construction

### AF10, AF20

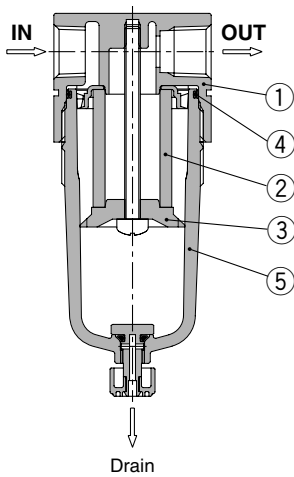

### AF30 to AF40-06

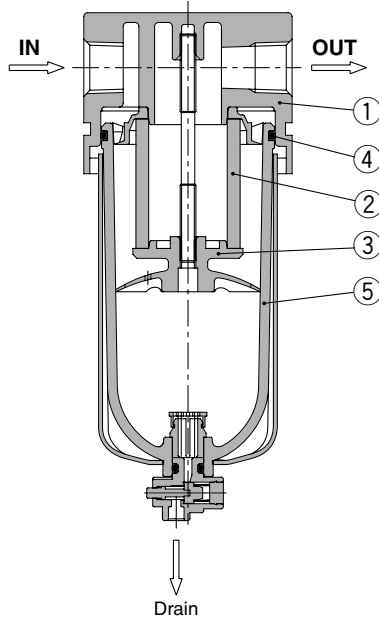

### AF50, AF60

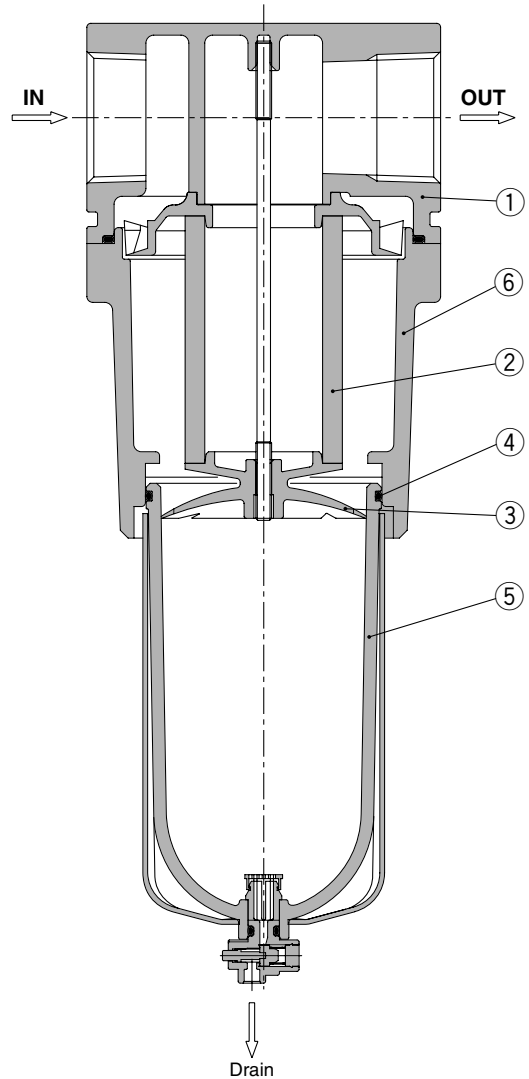

### Component Parts

No.	Description	Material	Model	Colour
1	Body	Zinc die-cast	AF10, AF20	Platinum silver
		Aluminum die-cast	AF30 to AF60	
6	Housing	Aluminum die-cast	AF50, AF60	Platinum silver

### Replacement Parts

No.	Description	Material	Part no.						
			AF10	AF20	AF30	AF40	AF40-06	AF50	AF60
2	Filter element	Non-woven fabric	AF10P-060S	AF20P-060S	AF30P-060S	AF40P-060S		AF50P-060S	AF60P-060S
3	Baffle	PBT	AF10P-040S <sup>Note 1)</sup>	AF20P-040S	AF30P-040S	AF40P-040S		AF50P-040S	AF60P-040S
4	Bowl O-ring	NBR	C1SFP-260S	C2SFP-260S	C3SFP-260S	C4SFP-260S			
5	Bowl assembly <sup>Note 2)</sup>	Polycarbonate	C1SF	C2SF	C3SF <sup>Note 3)</sup>	C4SF <sup>Note 3)</sup>			

Note 1) The material of the baffle for the AF10 (AF10P-040S) only is polyacetal.

Note 2) Bowl O-ring is included. Please contact SMC regarding the bowl assembly supply for PSI and °F unit specifications.

Note 3) Bowl assembly for the AF30 to AF60 models comes with a bowl guard (steel band material).

# Series AF10 to AF60

## Dimensions

### AF10, AF20

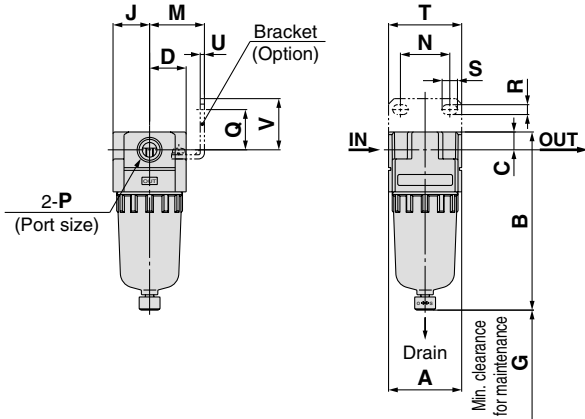

### AF50, AF60

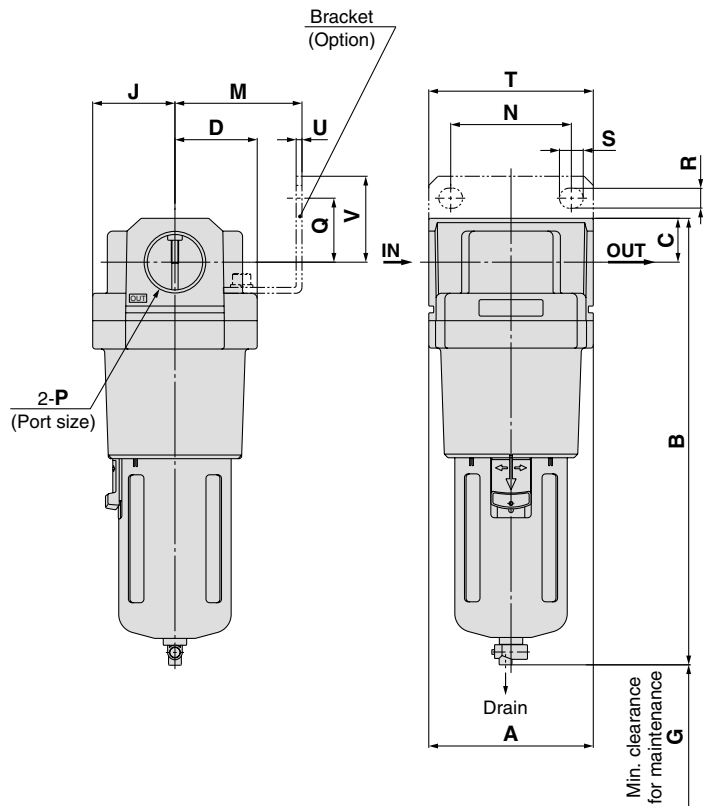

### AF30 to AF40-06

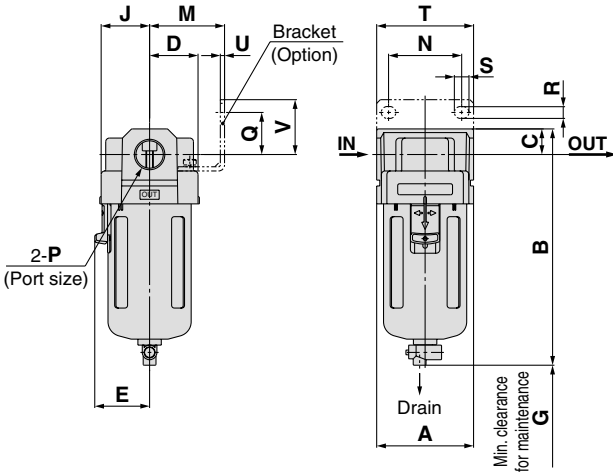

Applicable model	AF10, AF20		AF20	AF30 to AF60					
	Optional/Semi-standard specifications	With auto drain (N.C.)	Metal bowl	With drain guide	With auto drain (N.O./N.C.)	Metal bowl	Metal bowl with level gauge	With drain guide	Drain cock with barb fitting
Dimensions									

Model	Standard specifications								Optional specifications								
	P	A	B	C	D	E	G	J	M	N	Q	R	S	T	U	V	B
AF10	M5	25	67	7	12.5	—	25	12.5	—	—	—	—	—	—	—	—	85
AF20	1/8, 1/4	40	97	10	20	—	40	20	30	27	22	5.4	8.4	40	2.3	28	115
AF30	1/4, 3/8	53	129	14	26.5	30	50	26.5	41	40	23	6.5	8	53	2.3	30	170
AF40	1/4, 3/8, 1/2	70	165	18	35	38	75	35	50	54	26	8.5	10.5	70	2.3	35	204
AF40-06	3/4	75	169	20	45	38	75	45	50	54	25	8.5	10.5	70	2.3	34	208
AF50	3/4, 1	90	245	24	45	45	20	45	70	66	35	11	13	90	3.2	47	284
AF60	1	95	258	24	47.5	47.5	20	47.5	70	66	35	11	13	90	3.2	47	297

Model	Semi-standard specifications			
	With barb fitting	With drain guide	Metal bowl	Metal bowl with level gauge
	B	B	B	B
AF10	—	—	66	—
AF20	—	101	97	—
AF30	137	136	142	162
AF40	173	172	178	198
AF40-06	177	176	182	202
AF50	253	252	258	278
AF60	266	265	271	291

# Air Filter AF20 to AF60 Made to Order



Please contact SMC for detailed dimensions, specifications, and lead times.

## ① Special Temperature Environment

Special materials are used in the manufacturing of seals and resin parts to allow them to withstand various temperature conditions in cold or tropical (hot) climates.

### Specifications

Made-to-order part no.	-X430	-X440
Environment	Low temperature	High temperature
Ambient temperature (°C)	-30 to 60°C	-5 to 80°C
Fluid temperature (°C)	-5 to 60°C (with no freezing)	
Material	Rubber parts	Special NBR
	Main parts	FKM
	Metal (Aluminum die-cast, etc.)	

### Applicable Model

Model	AF30	AF40	AF40-06	AF50	AF60
Port size	1/4, 3/8	1/4, 3/8, 1/2	3/4	3/4, 1	1

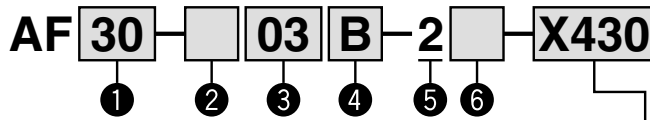

For high/low temperature

- Semi-standard: Select one each for a to c.
  - Semi-standard symbol: Enter them alphanumerically.
- Example) AF30-03B-2R-X430

X430	Low temperature
X440	High temperature

	Symbol	Description	① Body size			
			30	40	50	60
② Thread type	-	Rc	●	●	●	●
	N	NPT	●	●	●	●
	F	G	●	●	●	●
+						
③ Port size	02	1/4	●	●	-	-
	03	3/8	●	●	-	-
	04	1/2	-	●	-	-
	06	3/4	-	●	●	-
	10	1	-	-	●	●
+						
④ Option (Mounting) <small>Note 1</small>	-	Without mounting option	●	●	●	●
	B <small>Note 2</small>	With bracket	●	●	●	●
+						
⑤ Bowl <small>Note 3</small>	2	Metal bowl	●	●	●	●
+						
a Drain port	-	With drain cock	●	●	●	●
	J <small>Note 4</small>	Drain guide 1/4	●	●	●	●
+						
b Flow direction	-	Flow direction: Left to right	●	●	●	●
	R	Flow direction: Right to left	●	●	●	●
+						
c Pressure unit	-	Name plate and caution plate for bowl in SI units: MPa	●	●	●	●
	Z <small>Note 5</small>	Name plate and caution plate for bowl in imperial units (PSI, °F)	○ <small>Note 6</small>	○ <small>Note 6</small>	○ <small>Note 6</small>	○ <small>Note 6</small>

- Note 1) Option B is not assembled and is supplied loose at the time of shipment.  
 Note 2) Assembly includes a bracket and 2 mounting screws  
 Note 3) Only metal bowl 2 is available.  
 Note 4) Without a valve function  
 Note 5) For thread type: NPT. This product is for overseas use only according to the new Measurement Law. (The SI unit type is provided for use in Japan.)  
 Note 6) ○: For thread type: NPT only

## ② High Pressure

Strong materials are used in the manufacturing of air filters intended for high pressure operation.

### Specifications

Made-to-order part no.	-X425
Proof pressure (MPa)	3.0
Maximum operating pressure (MPa)	2.0
Ambient and fluid temperature (°C)	-5 to 60°C (with no freezing)

### Applicable Model

Model	AF20	AF30	AF40	AF40-06	AF50	AF60
Port size	1/8, 1/4	1/4, 3/8	1/4, 3/8, 1/2	3/4	3/4, 1	1

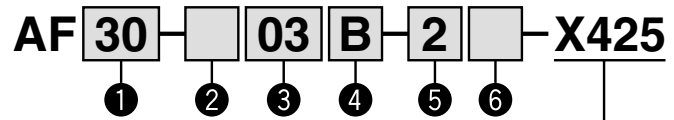

For high pressure

- Semi-standard: Select one each for a to c.
  - Semi-standard symbol: Enter them alphanumerically.
- Example) AF30-03B-2R-X425

	Symbol	Description	① Body size				
			20	30	40	50	60
② Thread type	-	Rc	●	●	●	●	●
	N	NPT	●	●	●	●	●
	F	G	●	●	●	●	●
+							
③ Port size	01	1/8	●	-	-	-	-
	02	1/4	●	●	●	-	-
	03	3/8	-	●	●	-	-
	04	1/2	-	-	●	-	-
	06	3/4	-	-	●	●	-
	10	1	-	-	-	●	●
+							
④ Option (Mounting) <small>Note 1</small>	-	Without mounting option	●	●	●	●	●
	B <small>Note 2</small>	With bracket	●	●	●	●	●
+							
⑤ Bowl <small>Note 3</small>	2	Metal bowl	●	●	●	●	●
	8	Metal bowl with level gauge	-	●	●	●	●
+							
a Drain port	-	With drain cock	●	●	●	●	●
	J <small>Note 4</small>	Drain guide 1/8	●	-	-	-	-
	J <small>Note 4</small>	Drain guide 1/4	-	●	●	●	●
+							
b Flow direction	-	Flow direction: Left to right	●	●	●	●	●
	R	Flow direction: Right to left	●	●	●	●	●
+							
c Pressure unit	-	Name plate and caution plate for bowl in SI units: MPa	●	●	●	●	●
	Z <small>Note 5</small>	Name plate and caution plate for bowl in imperial units (PSI, °F)	○ <small>Note 6</small>	○ <small>Note 6</small>	○ <small>Note 6</small>	○ <small>Note 6</small>	○ <small>Note 6</small>

- Note 1) Option B is not assembled and is supplied loose at the time of shipment.  
 Note 2) Assembly includes a bracket and 2 mounting screws  
 Note 3) Only metal bowl 2 and 8 are available.  
 Note 4) Without a valve function  
 Note 5) For thread type: NPT. This product is for overseas use only according to the new Measurement Law. (The SI unit type is provided for use in Japan.)  
 Note 6) ○: For thread type: NPT only

# Mist Separator

## AFM20 to AFM40

# Micro Mist Separator

## AFD20 to AFD40

JIS Symbol  
Mist Separator

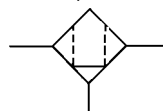

Symbol  
Micro Mist Separator

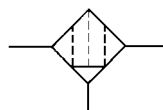

AFM20/AFD20 AFM40/AFD40

Series AFM Nominal filtration rating: 0.3 μm

Series AFD Nominal filtration rating: 0.01 μm

### How to Order

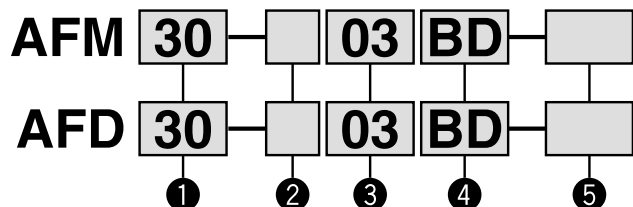

- Option / Semi-standard: Select one each for a to f.
- Option / Semi-standard symbol: When more than one specification is required, indicate in ascending alphanumeric order.  
Example) AC30-03BD-2R

	Symbol	Description	① Body size			
			20	30	40	
② Thread type	-	Rc	●	●	●	
	N <sup>Note 1)</sup>	NPT	●	●	●	
	F <sup>Note 2)</sup>	G	●	●	●	
+						
③ Port size	01	1/8	●	—	—	
	02	1/4	●	●	●	
	03	3/8	—	●	●	
	04	1/2	—	—	●	
	06	3/4	—	—	●	
+						
④ Option	a	- Without mounting option	●	●	●	
	B <sup>Note 4)</sup>	With bracket	●	●	●	
+						
b	-	Without auto drain	●	●	●	
	C	Float type auto drain (N.C.)	●	●	●	
	D	Float type auto drain (N.O.)	—	●	●	
+						
⑤ Semi-standard	c	-	Polycarbonate bowl	●	●	●
		2	Metal bowl	●	●	●
		6	Nylon bowl	●	●	●
		8	Metal bowl with level gauge	—	●	●
		C	With bowl guard	●	—	—
		6C	Nylon bowl with bowl guard	●	—	—
+						
d	J <sup>Note 6)</sup>	-	With drain cock	●	●	●
		-	Drain guide 1/8	●	—	—
		-	Drain guide 1/4	—	●	●
		W <sup>Note 7)</sup>	Drain cock with barb fitting: For ø6 x ø4 nylon tube	—	●	●
+						
e	R	-	Flow direction: Left to right	●	●	●
		-	Flow direction: Right to left	●	●	●
+						
f	Z <sup>Note 8)</sup>	-	Name plate and caution plate for bowl in SI units: MPa	●	●	●
		-	Name plate and caution plate for bowl in imperial units (PSI, °F)	● <sup>Note 9)</sup>	● <sup>Note 9)</sup>	● <sup>Note 9)</sup>

Note 1) Drain guide is NPT1/8 (applicable to the AFM20, AFD20), and NPT1/4 (applicable to the AFM30 to AFM40, AFD30 to AFD40). The exhaust port for auto drain comes with ø3/8" One-touch fitting (applicable to the AFM30 to AFM40, AFD30 to AFD40).

Note 2) Drain guide is G1/8 (applicable to the AFM20, AFD20) and G1/4 (applicable to the AFM30 to AFM40, AFD30 to AFD40).

Note 3) Option B is not assembled and is supplied loose at the time of shipment.

Note 4) Includes 2 mounting threads

Note 5) Float type auto drain: The combination between C or D is not available with the drain port options.

Note 6) Without a valve function

Note 7) Metal bowl: The combination of 2 or 8 cannot be selected with W.

Note 8) For thread type: NPT. This product is for overseas use only according to the new Measurement Law. (The SI unit type is provided for use in Japan.)

Note 9) ○: For thread type: NPT only

# Mist Separator *Series AFM20 to AFM40*

## Micro Mist Separator *Series AFD20 to AFD40*

### Standard Specifications

Model	AFM20 AFD20	AFM30 AFD30	AFM40 AFD40	AFM40-06 AFD40-06
<b>Port size</b>	1/8, 1/4	1/4, 3/8	1/4, 3/8, 1/2	3/4
<b>Fluid</b>	Air			
<b>Ambient and fluid temperature</b>	-5 to 60°C (with no freezing)			
<b>Proof pressure</b>	1.5 MPa			
<b>Maximum operating pressure</b>	1.0 MPa			
<b>Minimum operating pressure</b>	0.05 MPa			
<b>Nominal filtration rating</b>	AFM20 to AFM40-06			
	AFD20 to AFD40-06			
<b>Outlet side oil mist concentration</b>	AFM20 to AFM40-06			
	AFD20 to AFD40-06			
<b>Rated flow (ℓ/min (ANR))</b> <small>Note 1)</small>	AFM20 to AFM40-06			
	AFD20 to AFD40-06			
<b>Drain capacity (cm<sup>3</sup>)</b>	8	25	45	45
<b>Bowl material</b>	Polycarbonate			
<b>Bowl guard</b>	Semi-standard		Standard	
<b>Weight (kg)</b>	0.18	0.22	0.44	0.49

Note 1) Conditions: Inlet pressure: 0.5 MPa; The rated flow varies depending on the inlet pressure keep the air flow within the rated flow to prevent an outflow of lubricant to the outlet side.  
The exhaust port for auto drain comes with a ø3/8" One-touch fitting (applicable to the AFM30 to AFM40 and the AFD30 to AFD40).

Note 2) When the compressor oil mist discharge concentration is 30 mg/m<sup>3</sup> (ANR).  
Note 3) Bowl O-ring and other O-rings are slightly lubricated.

### Option / Part No.

Option	Model	AFM20 AFD20	AFM30 AFD30	AFM40 AFD40	AFM40-06 AFD40-06
<b>Bracket assembly</b> <small>Note 1)</small>		AF20P-050AS	AF30P-050AS	AR40P-050AS	AR40P-070AS
<b>Float type auto drain</b> <small>Note 2)</small>	N.O.	—	AD38	AD48	
	N.C.	AD27	AD37	AD47	

Note 1) Assembly includes a bracket and set nuts  
Note 2) Minimum operating pressure: N.O. type-0.1 MPa; N.C. type-0.1 MPa (AD27) and 0.15 MPa (AD37/47). Please contact SMC for PSI and °F unit specifications.

### Flow Characteristics (Representative values)

— : When saturated with oil  
- - - : Initial state

**AFM20**

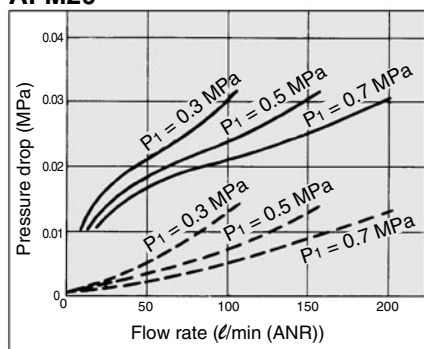

**AFM30**

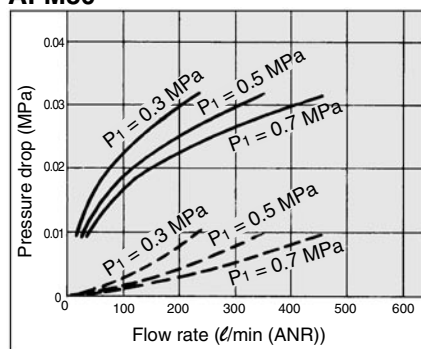

**AFM40**

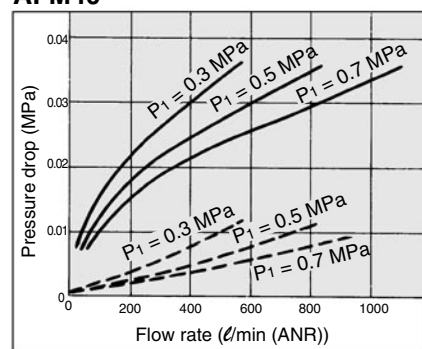

**AFD20**

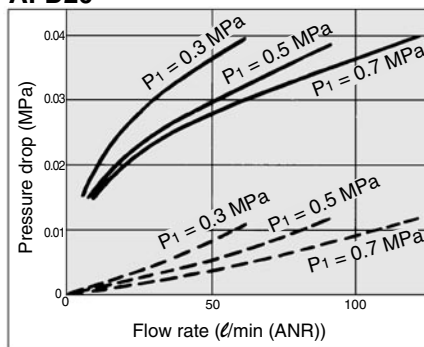

**AFD30**

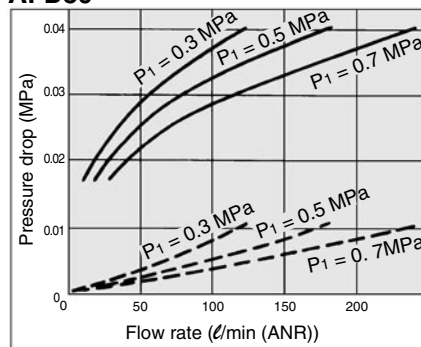

**AFD40**

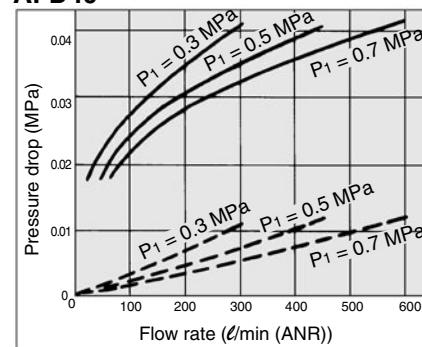

# Series AFM20 to AFM40

# Series AFD20 to AFD40

## ⚠ Specific Product Precautions

Be sure to read this before handling. Refer to "Precautions for Handling Pneumatic Devices" (M-03-E3A) for Safety Instructions and F.R.L. Unit Precautions.

### Air Supply

#### ⚠ Caution

1. Install an air filter (the AF series) as a preliminary filter on the inlet side of the mist separator to prevent premature clogging.
2. Install a mist separator (the AFM series) as a preliminary filter on the inlet side of the micro mist separator to prevent premature clogging.
3. Do not install on the inlet side of the dryer as this can cause premature clogging of the element.

### Maintenance

#### ⚠ Warning

1. Replace the element every 2 years or when the pressure drop becomes 0.1 MPa, whichever comes first, to prevent damage to the element.

### Design

#### ⚠ Caution

1. Design the system so that the mist separator is installed in a pulsation-free location. The difference between internal and external pressure inside the element should be kept within 0.1 MPa, as exceeding this value could cause damage.

### Selection

#### ⚠ Caution

1. Do not allow air flow that exceeds the rated flow. If the air flow is allowed outside the range of the rated flow even momentarily, drainage and lubricant may splash to the outlet side or cause damage to the component.
2. Do not use in a low pressure application (such as a blower). An F.R.L. unit has its own minimum operating pressure depending on the equipment and is designed specifically to function with compressed air. If used below the minimum operating pressure, a loss of performance and malfunction can occur. Please contact SMC if an application under such conditions cannot be avoided.

## Construction

### AFM20 AFD20

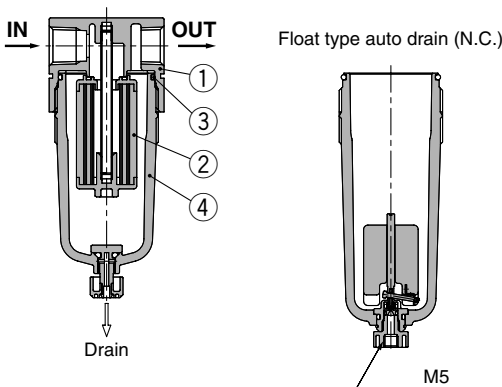

### AFM30 to AFM40-06 AFD30 to AFD40-06

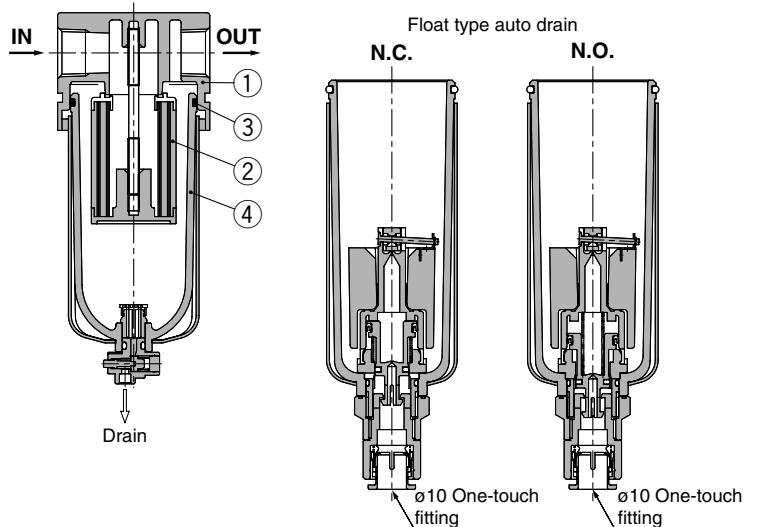

### Component Parts

No.	Description	Material	Model	Note
1	Body	Zinc die-cast	AFM20, AFD20	Platinum silver
		Aluminum die-cast	AFM30 to AFM40-06/AFD30 to AFD40-06	

### Replacement Parts

No.	Description	Material	Part no.			
			AFM20 AFD20	AFM30 AFD30	AFM40 AFD40	AFM40-06 AFD40-06
2	Element assembly	AFM20 to 40	AFM20P-060AS	AFM30P-060AS	AFM40P-060AS	
		AFD20 to 40	AFD20P-060AS	AFD30P-060AS	AFD40P-060AS	
3	Bowl O-ring	NBR	C2SFP-260S	C3SFP-260S	C4SFP-260S	
4	Bowl assembly <sup>Note 1)</sup>	Polycarbonate	C2SF	C3SF <sup>Note 2)</sup>	C4SF <sup>Note 2)</sup>	

Note 1) Includes O-ring. Please contact SMC regarding the bowl assembly supply for PSI and °F unit specifications.

Note 2) Bowl assembly for the AFM30 to AFM40-06 and the AFD30 to AFD40-06 includes a bowl guard (steel band material).

# Mist Separator *Series AFM20 to AFM40*

## Micro Mist Separator *Series AFD20 to AFD40*

### Dimensions

**AFM20  
AFD20**

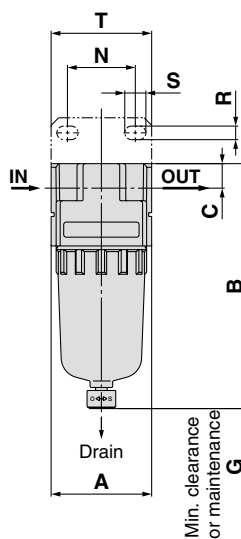
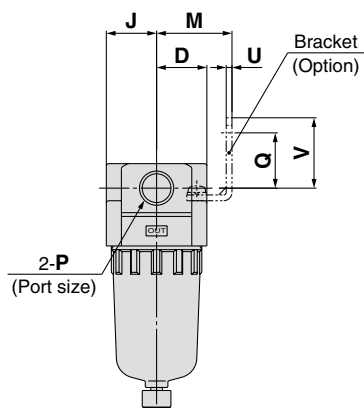

**AFM30 to AFM40-06  
AFD30 to AFD40-06**

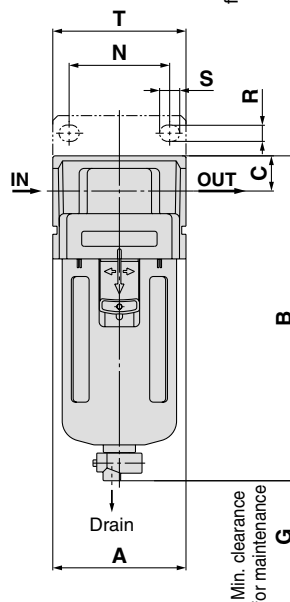
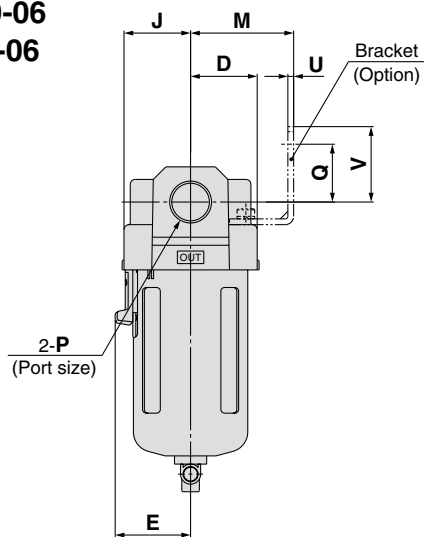



Applicable model Optional/Semi-standard specifications	AFM20, AFD20			AFM30 to AFM40-06, AFD30 to AFD40-06				
	With auto drain (N.C.)	Metal bowl	With drain guide	With auto drain (N.O./N.C.)	Metal bowl	Metal bowl with level gauge	With drain guide	Drain cock with barb fitting
Dimensions	 M5	 M5	 1/8 Width across flats 14	 N.O.: Black N.C.: Gray ø10 One-touch fitting	 M5	 M5	 1/4 Width across flats 17	 Barb fitting Applicable tubing: T0604

Model	Standard specifications								Optional specifications								
	P	A	B	C	D	E	G	J	Bracket mount							With auto drain	
									M	N	Q	R	S	T	U		V
AFM20, AFD20	1/8, 1/4	40	97	10	20	—	40	20	30	27	22	5.4	8.4	40	2.3	28	115
AFM30, AFD30	1/4, 3/8	53	129	14	26.5	30	50	26.5	41	40	23	6.5	8	53	2.3	30	170
AFM40, AFD40	1/4, 3/8, 1/2	70	165	18	35	38	75	35	50	54	26	8.5	10.5	70	2.3	35	204
AFM40-06, AFD40-06	3/4	75	169	20	45	38	75	45	50	54	25	8.5	10.5	70	2.3	34	208

Model	Semi-standard specifications			
	With barb fitting	With drain gauge	Metal bowl	Metal bowl with level gauge
	B	B	B	B
AFM20, AFD20	—	101	97	—
AFM30, AFD30	137	136	142	162
AFM40, AFD40	173	172	178	198
AFM40-06, AFD40-06	177	176	182	202



# Modular Type Regulators *Series AR*

Regulator Series AR	Model	Port size	Option
 <p data-bbox="167 952 470 985">Page 41 through to 49</p>	AR10	M5	Bracket Square embedded type pressure gauge (except for AR10) Digital pressure switch (except for AR10)
	AR20	1/8, 1/4	
	AR25	1/4, 3/8	
	AR30	1/4, 3/8	
	AR40	1/4, 3/8, 1/2	
	AR40-06	3/4	
	AR50	3/4, 1	
	AR60	1	
 <p data-bbox="167 1377 470 1411">Page 41 through to 49</p>	AR20K	1/8, 1/4	Round type pressure gauge Panel mount
	AR25K	1/4, 3/8	
	AR30K	1/4, 3/8	
	AR40K	1/4, 3/8, 1/2	
	AR40K-06	3/4	
	AR50K	3/4, 1	
	AR60K	1	

# Regulator

# AR10 to AR60

## Regulator with Backflow Mechanism

# AR20K to AR60K

JIS Symbol  
Regulator

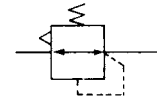

Symbol  
Regulator with  
Backflow Mechanism

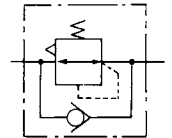

With the backflow function it incorporates a mechanism to exhaust the air pressure in the outlet side reliably and quickly.

Example 1)

When the pressure in the rear and the front of the cylinder differs:

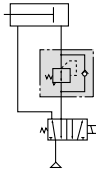

Example 2)

When the air supply is cut off and releasing the inlet pressure to the atmosphere, the residual pressure release of the outlet side can be ensured for a safety purpose.

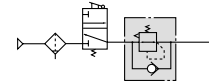

## How to Order

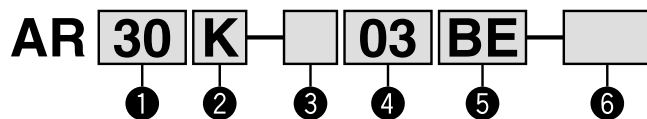

- Option / Semi-standard: Select one each for a to g.
- Option / Semi-standard symbol: Enter them alphanumerically.  
Example) AR30K-03BE-1NR

	Symbol	Description	①								
			Body size								
			10	20	25	30	40	50	60		
②	-	Without backflow mechanism	●	●	●	●	●	●	●		
	K <small>Note 1)</small>	With backflow mechanism	—	●	●	●	●	●	●		
+											
③	-	Metric thread (M5)	●	—	—	—	—	—	—		
	Rc		—	●	●	●	●	●	●		
	N	NPT	—	●	●	●	●	●	●		
	F	G	—	●	●	●	●	●	●		
+											
④	M5	M5	●	—	—	—	—	—	—		
	01	1/8	—	●	—	—	—	—	—		
	02	1/4	—	●	●	●	●	—	—		
	03	3/8	—	—	●	●	●	—	—		
	04	1/2	—	—	—	—	●	—	—		
	06	3/4	—	—	—	—	—	●	—		
	10	1	—	—	—	—	—	●	●		
+											
⑤ <small>Note 2)</small> Option	a	-	Without mounting option	●	●	●	●	●	●	●	
		B <small>Note 3)</small>	With bracket	●	●	●	●	●	●	●	
		H	With set nut (for panel fitting)	●	●	●	●	—	—	—	
	+										
	b	Pressure switch	-	Without pressure gauge	●	●	●	●	●	●	●
			E	Square embedded type pressure gauge (with limit indicator)	—	●	●	●	●	●	●
			G	Round type pressure switch (without limit indicator)	●	—	—	—	—	—	—
			G	Round type pressure switch (with limit indicator)	—	●	●	●	●	●	●
		Digital pressure switch	E1 <small>Note 4)</small>	Output: NPN output / Electrical entry: Wiring bottom entry	—	●	●	●	●	●	●
			E2 <small>Note 4)</small>	Output: NPN output / Electrical entry: Wiring top entry	—	●	●	●	●	●	●
	E3 <small>Note 4)</small>		Output: PNP output / Electrical entry: Wiring bottom entry	—	●	●	●	●	●	●	
	E4 <small>Note 4)</small>		Output: PNP output / Electrical entry: Wiring top entry	—	●	●	●	●	●	●	

# Regulator *Series AR10 to AR60*

## Regulator with Backflow Mechanism *Series AR20K to AR60K*



**AR20/AR20K      AR40/AR40K**

					①								
					Body size								
					10	20	25	30	40	50	60		
<b>6</b>	Semi-standard	<b>c</b>	Set pressure	-	0.05 to 0.85 MPa set	●	●	●	●	●	●	●	
				<b>1</b> <small>Note 5)</small>	0.02 to 0.2 MPa set	●	●	●	●	●	●	●	●
						+							
		<b>d</b>	Exhaust mechanism	-	Relieving type	●	●	●	●	●	●	●	●
				<b>N</b>	Non-relieving type	●	●	●	●	●	●	●	●
						+							
		<b>e</b>	Flow direction	-	Flow direction: Left to right	●	●	●	●	●	●	●	●
				<b>R</b>	Flow direction: Right to left	●	●	●	●	●	●	●	●
						+							
		<b>f</b>	Handle facing	-	Downward facing handle	●	●	●	●	●	●	●	●
				<b>Y</b>	Upward facing handle	●	●	●	●	●	●	●	●
						+							
		<b>g</b>	Pressure unit	-	Name plate and pressure gauge in SI units: MPa	●	●	●	●	●	●	●	●
				<b>Z</b> <small>Note 6)</small>	Name plate and pressure gauge in imperial units (PSI)	○ <small>Note 8)</small>	○ <small>Note 8)</small>	○ <small>Note 8)</small>	○ <small>Note 8)</small>	○ <small>Note 8)</small>	○ <small>Note 8)</small>	○ <small>Note 8)</small>	○ <small>Note 8)</small>
				<b>ZA</b> <small>Note 7)</small>	Digital pressure switch: With unit switching function	—	△ <small>Note 9)</small>	△ <small>Note 9)</small>	△ <small>Note 9)</small>	△ <small>Note 9)</small>	△ <small>Note 9)</small>	△ <small>Note 9)</small>	△ <small>Note 9)</small>

Note 1) The AR10 comes with a backflow mechanism as a standard feature. (K is not available.) When using the backflow mechanism, back flow may not occur with a set pressure of (of the AR10 type) 0.15 MPa or less.

Note 2) Option B, G and H are not assembled and are supplied loose at the time of shipment.

Note 3) Assembly includes a bracket and set nuts (the AR10, AR20(K) to AR40(K)) Including 2 mounting screws for the AR50(K) and AR60(K)

Note 4) When choosing with H (panel mount), the installation space for the lead wire will be limited. In this case, select "wiring top entry" for the lead wire entry. (Select "wiring bottom entry" when the semi-standard Y is chosen simultaneously.)

Note 5) The only difference from the standard specifications is the adjusting spring for the regulator. It does not restrict the setting of 0.2 MPa or more. When the pressure gauge is attached, a 0.2 MPa pressure gauge will be fitted.

Note 6) For thread type: M5 and NPT. This product is for overseas use only according to the new Measurement Law. (The SI unit type is provided for use in Japan.) The digital pressure switch will be equipped with the unit switching function, setting to PSI initially.

Note 7) For options: E1, E2, E3, E4. This product is for overseas use only according to the new Measurement Law. (The SI unit is provided for use in Japan.)

Note 8) ○: For thread type: M5 and NPT only

Note 9) △: Combination available for options: E1, E2, E3, E4.

### Standard Specifications

Model	AR10	AR20(K)	AR25(K)	AR30(K)	AR40(K)	AR40(K)-06	AR50(K)	AR60(K)	
<b>Port size</b>	M5 x 0.8	1/8, 1/4	1/4, 3/8	1/4, 3/8	1/4, 3/8, 1/2	3/4	3/4, 1	1	
<b>Pressure gauge port size</b> <small>Note 1)</small>	1/16 <small>Note 2)</small>	1/8			1/4				
<b>Fluid</b>	Air								
<b>Ambient and fluid temperature</b> <small>Note 3)</small>	-5 to 60°C (with no freezing)								
<b>Proof pressure</b>	1.5 MPa								
<b>Maximum operating pressure</b>	1.0 MPa								
<b>Set pressure range</b>	0.05 to 0.7 MPa	0.05 to 0.85 MPa							
<b>Relief pressure</b> <small>Note 4)</small>	Set pressure + 0.05 MPa <small>Note 3)</small> [at relief flow rate of 0.1 ℓ/min (ANR)]								
<b>Construction</b>	Relieving type								
<b>Weight (kg)</b>	0.06	0.26	0.21	0.29	0.44	0.47	1.17	1.22	

Note 1) Pressure gauge connection threads are not available for units with a square embedded type pressure gauge (the AR20(K) to AR60(K)).

Note 2) Use a bushing (part no.131368) when connecting the R 1/8 pressure gauge to the R 1/16.

Note 3) -5 to 50°C for the products with the digital pressure switch.

Note 4) Not applicable for AR10.

# Series AR10 to AR60

# Series AR20K to AR60K

## Option / Part No.

Option		Model	AR10	AR20(K)	AR25(K)	AR30(K)	AR40(K)	AR40(K)-06	AR50(K)	AR60(K)	
<b>Bracket assembly</b> <small>Note 1)</small>			AR10P-270AS	AR20P-270AS	AR25P-270AS	AR30P-270AS	AR40P-270AS		AR50P-270AS <small>Note 2)</small>		
<b>Set nut</b>			AR10P-260S	AR20P-260S	AR25P-260S	AR30P-260S	AR40P-260S		— <small>Note 3)</small>	— <small>Note 3)</small>	
<b>Pressure gauge</b>	<small>Note 4)</small> Round type	<b>Standard</b>	G27-10-R1	G36-10-□01			G46-10-□02				
		<b>0.02 to 0.2 MPa set</b>	G27-10-R1 <small>Note 5)</small>	G36-2-□01			G46-2-□02				
	<small>Note 6)</small> Square embedded type	<b>Standard</b>	—	GC3-10AS [GC3P-010AS (Pressure gauge cover only)]							
		<b>0.02 to 0.2 MPa set</b>	—	GC3-2AS [GC3P-010AS (Pressure gauge cover only)]							
<b>Digital pressure switch</b>	<small>Note 7)</small>	NPN output: Wiring bottom entry	—	ISE35-N-25-MLA [ISE35-N-25-M (Switch body only)]							
		NPN output: Wiring top entry	—	ISE35-R-25-MLA [ISE35-R-25-M (Switch body only)]							
		PNP output: Wiring bottom entry	—	ISE35-N-65-MLA [ISE35-N-65-M (Switch body only)]							
		PNP output: Wiring top entry	—	ISE35-R-65-MLA [ISE35-R-65-M (Switch body only)]							

Note 1) Assembly includes a bracket and set nuts

Note 2) Assembly includes a bracket and 2 mounting screws

Note 3) Please consult with SMC regarding the set nuts for the AR50(K) and AR60(K).

Note 4) □ in part numbers for a round pressure gauge indicates a type of connection thread. No indication is necessary for R; however, indicate N for NPT. Please contact SMC regarding the connection thread NPT and pressure gauge supply for PSI unit specifications.

Note 5) Pressure gauge for general purpose

Note 6) Includes one O-ring and 2 mounting screws. [ ]: Pressure gauge cover only

Note 7) Lead wire with connector (2 m), adaptor, lock pin, O-ring (1 pc.), mounting screw (2 pcs.) are attached. [ ]: Switch body only  
Also, regarding how to order the digital switch, please refer to page 73.

## ⚠ Specific Product Precautions

**Be sure to read this before handling. Refer to “Precautions for Handling Pneumatic Devices” (M-03-E3A) for Safety Instructions and F.R.L. Unit Precautions.**

### Selection

#### ⚠ Warning

- Residual pressure disposal (outlet pressure removal) is not possible for the AR20 to 60 even though the inlet pressure is exhausted. When the residual pressure disposal is performed, use the regulator with a backflow mechanism (the AR20K to AR60K).

### Maintenance

#### ⚠ Warning

- When using the regulator with backflow mechanism between a solenoid valve and an actuator, check the pressure gauge periodically. Sudden pressure fluctuations may shorten the durability of the pressure gauge. A digital pressure gauge is recommended for such situation or as deemed necessary.

### Mounting and Adjustment

#### ⚠ Warning

- Set the regulator while verifying the displayed values of the inlet and outlet pressure gauges. Turning the regulator knob excessively can cause damage to the internal parts.
- The pressure gauge included with regulators for 0.02 to 0.2 MPa setting is for up to 0.2 MPa use only (except for the AR10). Exceeding 0.2 MPa of pressure can damage the gauge.
- Do not use tools on the pressure regulator knob as this may cause damage. It must be operated manually.

#### ⚠ Caution

- Be sure to unlock the knob before adjusting the pressure and lock it after setting the pressure. Failure to follow this procedure can cause damage to the knob and the outlet pressure may fluctuate.
  - Pull the pressure regulator knob to unlock. (You can visually verify this with the “orange mark” that appears in the gap.)
  - Push the pressure regulator knob to lock. When the knob is not easily locked, turn it left and right a little and then push it (when the knob is locked, the “orange mark”, i.e., the gap will disappear).

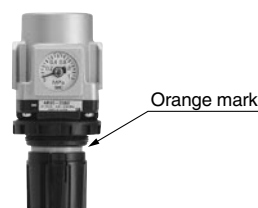

- A knob cover is available to prevent careless operation of the knob. Refer to “Features 1” for details.

## Flow Characteristics (Representative values)

Condition: Inlet pressure 0.7 MPa

**AR10** M5

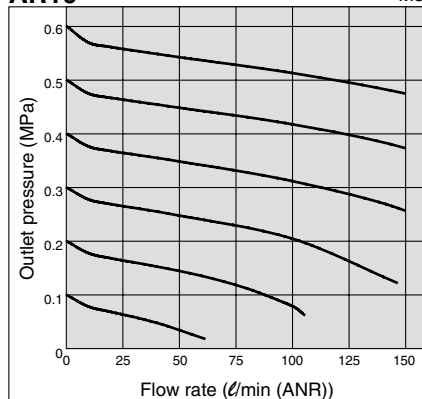

**AR30(K)** Rc 3/8

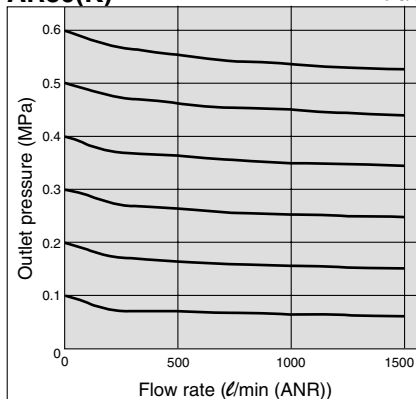

**AR50(K)** Rc 1

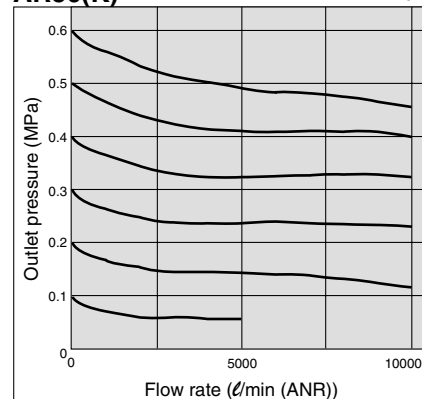

**AR20(K)** Rc 1/4

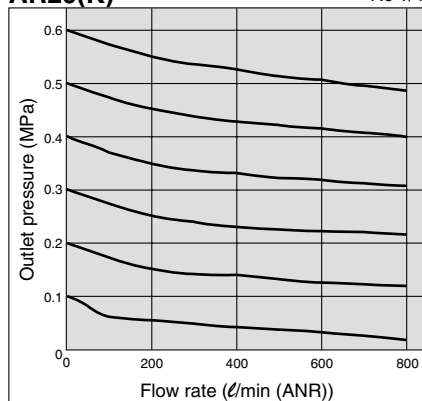

**AR40(K)** Rc 1/2

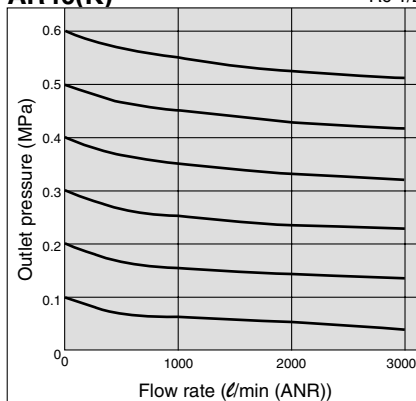

**AR60(K)** Rc 1

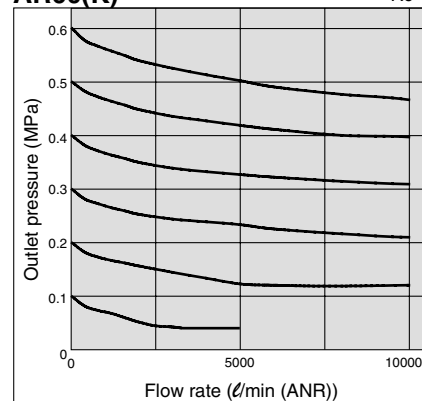

**AR25(K)** Rc 3/8

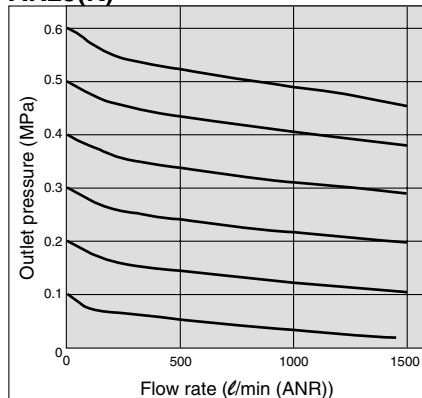

**AR40(K)-06** Rc 3/4

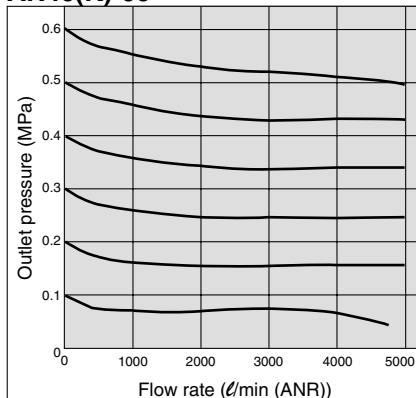

# Series AR10 to AR60

## Series AR20K to AR60K

### Pressure Characteristics (Representative values)

Conditions: Inlet pressure 0.7 MPa, Outlet pressure 0.2 MPa, Flow rate 20 l/min (ANR)

**AR10**

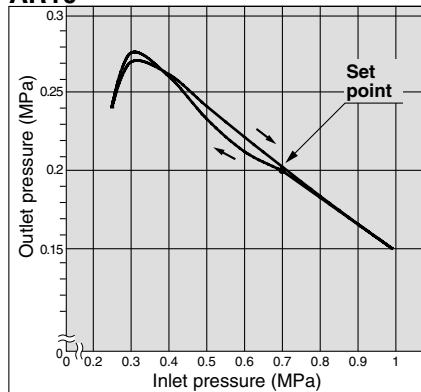

**AR30(K)**

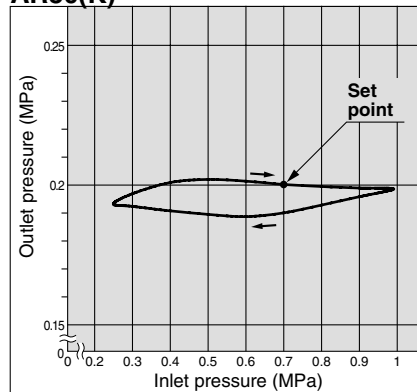

**AR50(K)**

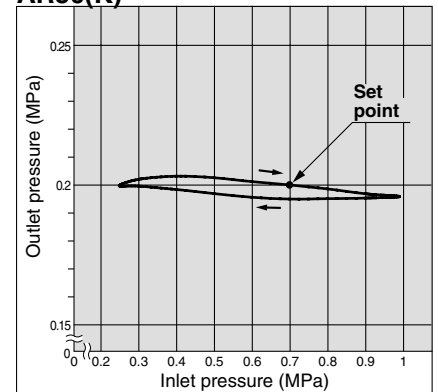

**AR20(K)**

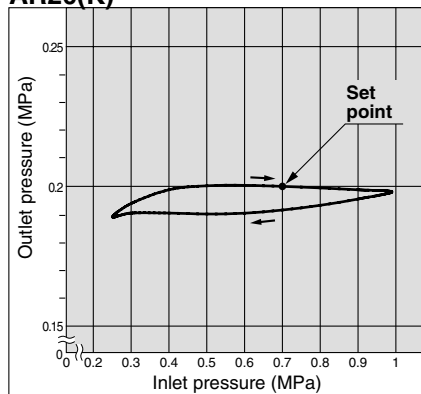

**AR40(K)**

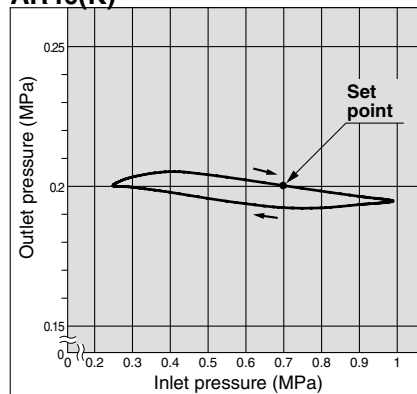

**AR60(K)**

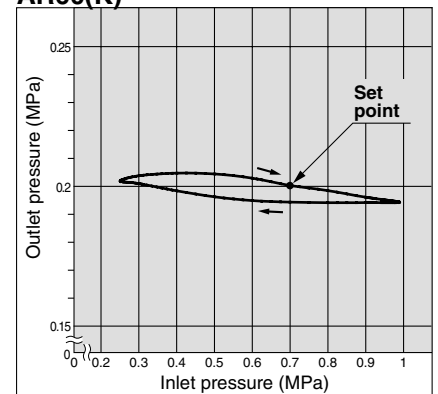

**AR25(K)**

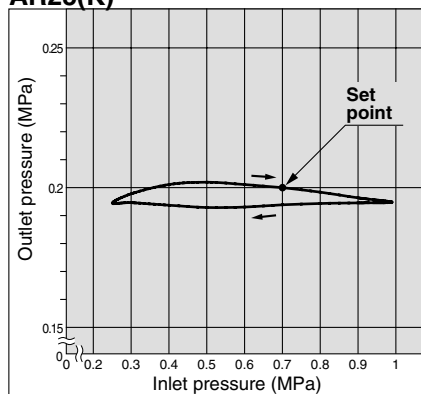

**AR40(K)-06**

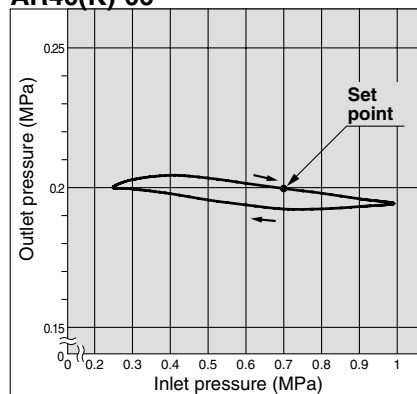

# Regulator *Series AR10 to AR60*

## Regulator with Backflow Mechanism *Series AR20K to AR60K*

### Construction

#### AR10

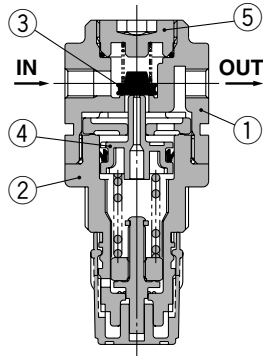

#### AR20(K), AR25(K)

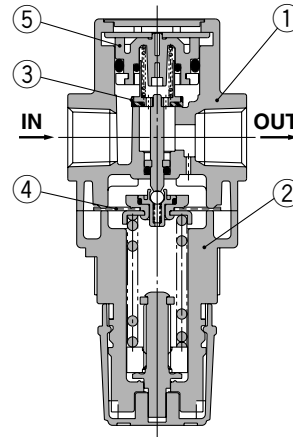

#### AR30(K), AR40(K)

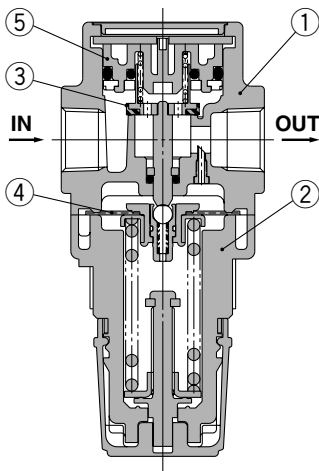

#### AR50(K), AR60(K)

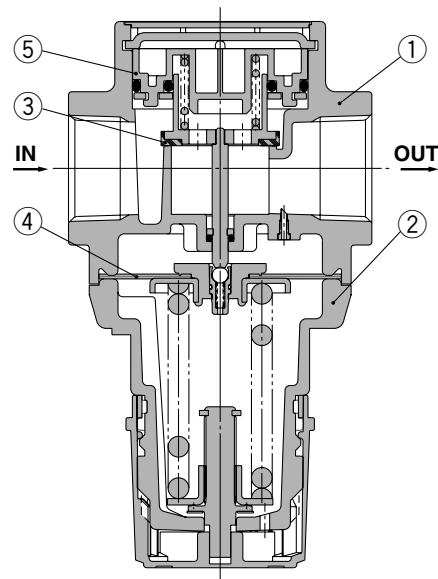

#### AR20K to AR60K (Regulator with Backflow Mechanism)

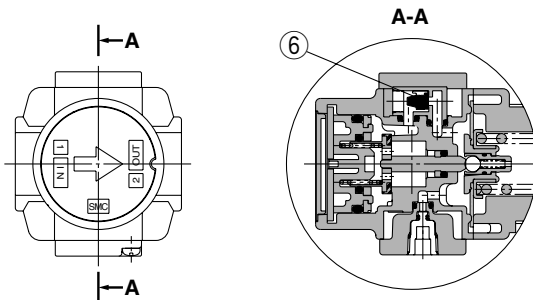

### Component Parts

No.	Description	Material	Model	Note
1	Body	Zinc die-cast	AR10, AR20(K)	Platinum silver
		Aluminum die-cast	AR25(K) to AR60(K)	
2	Bonnet	Polyacetal	AR10, AR20(K) to AR40(K)-06	Black
		Aluminum die-cast	AR50(K), AR60(K)	

### Replacement Parts

No.	Description	Material	Part no.						
			AR10	AR20(K)	AR25(K)	AR30(K)	AR40(K)	AR40(K)-60	AR50(K)
3	Valve assembly	Brass, HNBR	AR10P-090S	AR20P-410S	AR25P-410S	AR30P-410S	AR40P-410S	AR50P-410S	AR60P-410S
4	Diaphragm assembly	Weatherable NBR	AR10P-150AS <sup>Note 1)</sup>	AR20P-150AS	AR25P-150AS	AR30P-150AS	AR40P-150AS	AR50P-150AS	
5	Valve guide assembly	Polyacetal	131329	AR20P-050AS	AR25P-050AS	AR30P-050AS	AR40P-050AS	AR50P-050AS	AR60P-050AS
6	Check valve assembly <sup>Note 2)</sup>	—	—	AR20KP-020AS					

Note 1) The AR10 is a piston type. Assembly includes a piston and a seal (KSYP-13).

Note 2) Check valve assembly is applicable for a regulator with backflow mechanism (the AR20K to AR60K) only.

Assembly includes a check valve cover, check valve body assembly and 2 screws

# Series AR10 to AR60

## Series AR20K to AR60K

### Working Principle (Regulator with Backflow Mechanism)

#### AR10

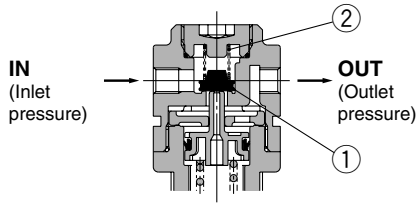

Figure 1

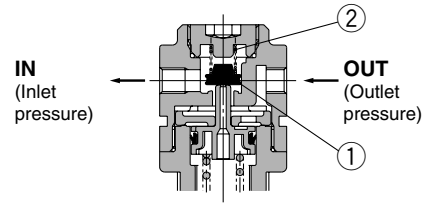

Figure 2

When the inlet pressure is higher than the regulating pressure, the check valve operates as a normal regulator (Figure 1). When the inlet pressure is shut off and exhausted, any inlet pressure applied to valve ① will be lost. The force for seating valve ① is the valve spring ② force only. When valve ① is opened using the outlet force, the outlet pressure will be exhausted at the inlet side. (Figure 2)

When the set pressure is 0.15 MPa or less, valve ① may not open due to the force of valve spring ②.

#### AR20K to AR60K

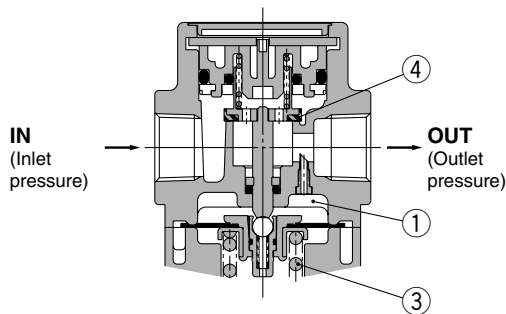
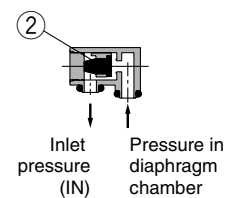
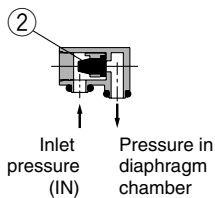
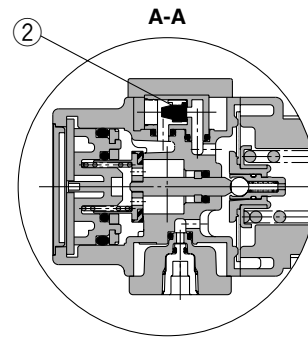
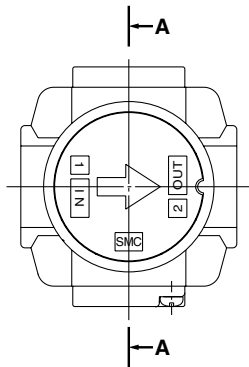

Figure 1 Normal

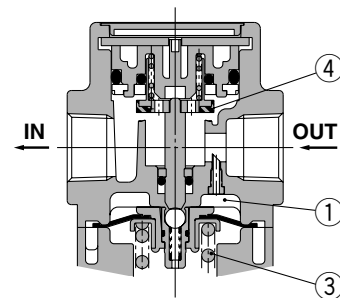

Figure 2 Back flow

When the inlet pressure is higher than the regulating pressure, check valve ② closes and operates as a normal regulator (Figure 1). When the inlet pressure is shut off and released, check valve ② opens and the pressure in diaphragm chamber ① is released into the inlet side (Figure 2). This lowers the pressure in the diaphragm chamber ① and the force generated by pressure regulator spring ③ lifts the diaphragm. Valve ④ opens through the stem, and the outlet pressure is released to the inlet side (Figure 2).

# Regulator **Series AR10 to AR60**

## Regulator with Backflow Mechanism **Series AR20K to AR60K**

### Dimensions

#### AR10, AR20(K) to AR40(K)-06

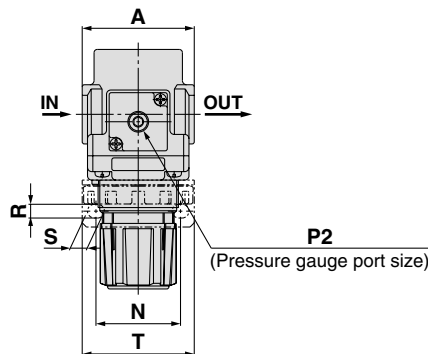
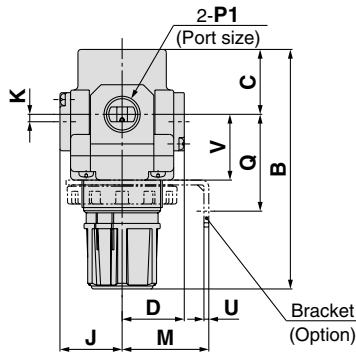

Panel fitting dimensions

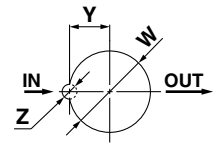

AR10, AR20(K) to AR30(K): Max. 3.5  
AR40(K): Max. 5

#### AR50(K), AR60(K)

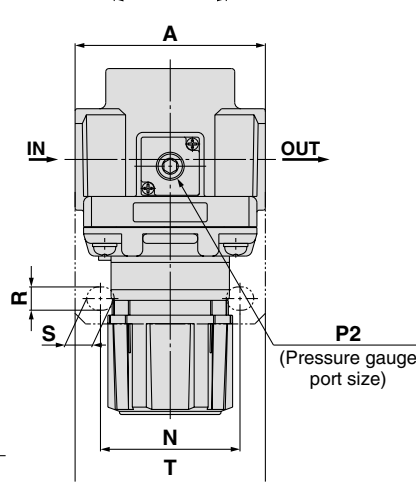
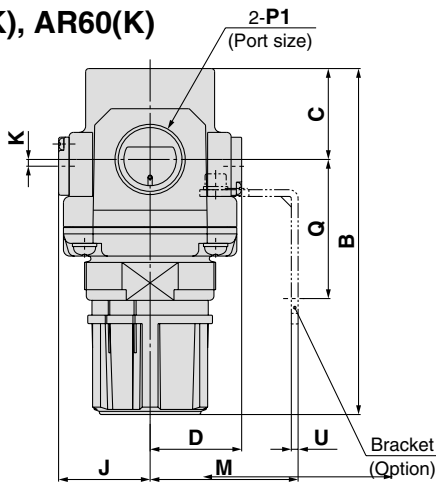

Applicable model	AR20(K) to AR60(K)		AR10, AR20(K) to AR60(K)
Option	Square embedded type pressure gauge	Digital pressure switch	Round type pressure gauge
Dimensions	Centre of piping	Centre of piping	Centre of piping

Model	Standard specifications									Optional specifications					
	P1	P2	A	B <small>Note 1)</small>	C	D	F	J	K	Square type pressure gauge	Digital pressure gauge	Round type pressure gauge			
AR10	M5 x 0.8	1/16	25	58	11	12.5	M18 x 1	13	0	—	—	—	—	ø26	26
AR20(K)	1/8, 1/4	1/8	40	94	26.5	28.5	M28 x 1	28.5 <small>Note 2)</small>	2	□28	29.5	□27.8	40	ø37.5	65
AR25(K)	1/4, 3/8	1/8	53	101	28	27.5	M32 x 1.5	27.5	0	□28	28.5	□27.8	39	ø37.5	64
AR30(K)	1/4, 3/8	1/8	53	116	31	29.5	M38 x 1.5	29.5	3.5	□28	30.5	□27.8	41	ø37.5	66
AR40(K)	1/4, 3/8, 1/2	1/4	70	128	36	34	M42 x 1.5	34	3.5	□28	35	□27.8	45	ø42.5	74
AR40(K)-06	3/4	1/4	75	129	36	34	M42 x 1.5	34	3	□28	35	□27.8	45	ø42.5	74
AR50(K)	3/4, 1	1/4	90	169	43	43.5	M62 x 1.5	43.5	3.3	□28	44.5	□27.8	55	ø42.5	84
AR60(K)	1	1/4	95	176	46	43.5	M62 x 1.5	43.5	3.3	□28	44.5	□27.8	55	ø42.5	84

Model	Optional specifications										
	Bracket mount							Panel mount			
	M	N	Q	R	S	T	U	V	W	Y	Z
AR10	25	28	30	4.5	6.5	40	2	18	18.5	—	—
AR20(K)	30	34	44	5.4	15.4	55	2.3	25	28.5	14	6
AR25(K)	30	34	44	5.4	15.4	55	2.3	26	32.5	16	6
AR30(K)	41	40	46	6.5	8	53	2.3	31	38.5	19	7
AR40(K)	50	54	54	8.5	10.5	70	2.3	35.5	42.5	21	7
AR40(K)-06	50	54	56	8.5	10.5	70	2.3	37	42.5	21	7
AR50(K)	70	66	65.8	11	13	90	3.2	—	—	—	—
AR60(K)	70	66	65.8	11	13	90	3.2	—	—	—	—

Note 1) The total length of B direction is the length when the filter regulator handle is unlocked.  
Note 2) For the AR20 only, the position of the pressure gauge is above the centre of the piping.

# Air Filter AR20 to AR60 Made to Order



Please contact SMC for detailed dimensions, specifications, and lead times.



AR30-03-X425

## ① Special Temperature Environment

Special materials are used in the manufacturing of seals and resin parts to allow them to withstand various temperature conditions in cold or tropical (hot) climates.

### Specifications

Made-to-order part no.	-X430	-X440
Environment	Low temperature	High temperature
Ambient temperature (°C)	-30 to 60°C	-5 to 80°C
Fluid temperature (°C)	-5 to 60°C (with no freezing)	
Material	Rubber parts	Special NBR
	Main parts	FKM
	Metal (Aluminum die-cast), etc.	

### Applicable Model

Model	AR25	AR30	AR40	AR40-06	AR50	AR60
Port size	1/4, 3/8	1/4, 3/8	1/4, 3/8, 1/2	3/4	3/4, 1	1

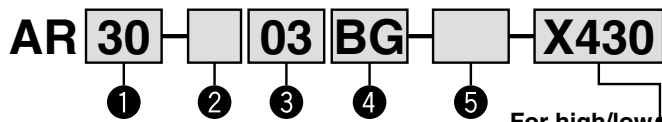

- Option / Semi-standard: Select one each for a to g.
  - Option / Semi-standard symbol: Enter them alphanumerically.
- Example) AR30-03BG-1NR-X430

X430	Low temperature
X440	High temperature

	Symbol	Description	① Body size					
			25	30	40	50	60	
② Thread type	-	Rc	●	●	●	●	●	
	N	NPT	●	●	●	●	●	
	F	G	●	●	●	●	●	
③ Port size	02	1/4	●	●	●	—	—	
	03	3/8	●	●	●	—	—	
	04	1/2	—	—	●	●	—	
	06	3/4	—	—	●	●	—	
	10	1	—	—	—	●	●	
④ Option	a Mounting	-	Without mounting option	●	●	●	●	●
		B	With bracket	●	●	●	●	●
		H	With set nut (for panel fitting)	●	●	●	—	—
④ Option	b Pressure gauge	-	Round type pressure switch (without limit indicator)	●	●	●	●	●
		G	Round type pressure switch (with limit indicator)	●	●	●	●	●
⑤ Semi-standard	c Set pressure	-	0.05 to 0.85 MPa set	●	●	●	●	●
		1	0.02 to 0.2 MPa set	●	●	●	●	●
⑤ Semi-standard	d Exhaust mechanism	-	Relieving type	●	●	●	●	●
		N	Non-relieving type	●	●	●	●	●
⑤ Semi-standard	e Flow direction	-	Flow direction: Left to right	●	●	●	●	●
		R	Flow direction: Right to left	●	●	●	●	●
⑤ Semi-standard	f Handle facing	-	Downward facing handle	●	●	●	●	●
		Y	Upward facing handle	●	●	●	●	●
⑤ Semi-standard	g Pressure unit	-	Name plate and pressure gauge in SI units: MPa	●	●	●	●	●
		Z	Name plate and pressure gauge in imperial units (PSI)	○	○	○	○	○

- Note 1) Option B, G and H are not assembled and are supplied loose at the time of shipment.
- Note 2) Assembly includes a bracket and set nuts (the AR25 to AR40) Includes 2 mounting screws for the AR50 and AR60
- Note 3) Mounting thread for pressure gauge: 1/8 for the AR25 to AR30; 1/4 for the AR40 to AR60. Pressure gauge type: G43
- Note 4) The only difference from the standard specifications is the adjusting spring for the regulator. It does not restrict the setting of 0.2 MPa or more. When the pressure gauge is attached, a 0.2 MPa pressure gauge will be fitted.
- Note 5) For thread type: NPT. This product is for overseas use only according to the new Measurement Law. (The SI unit type is provided for use in Japan.)
- Note 6) ○: For thread type: NPT only

## ② High Pressure

Strong materials are used in the manufacturing of air filters intended for high pressure operation. Also, construction modification allows a wider regulating pressure range.

### Specifications

Made-to-order part no.	-X425
Proof pressure (MPa)	3.0
Maximum operating pressure (MPa)	2.0
Set pressure range (MPa)	0.1 to 1.6
Ambient and fluid temperature (°C)	-5 to 60°C (with no freezing)

### Applicable Model

Model	AR20	AR25	AR30	AR40	AR40-06	AR50	AR60
Port size	1/8, 1/4	1/4, 3/8	1/4, 3/8	1/4, 3/8, 1/2	3/4	3/4, 1	1

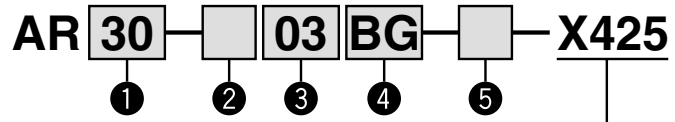

- Option / Semi-standard: Select one each for a to f.
  - Option / Semi-standard symbol: Enter them alphanumerically.
- Example) AR30-03BG-NR-X425

	Symbol	Description	① Body size					
			20	25	30	40	50	60
② Thread type	-	Rc	●	●	●	●	●	
	N	NPT	●	●	●	●	●	
	F	G	●	●	●	●	●	
③ Port size	01	1/8	●	—	—	—	—	
	02	1/4	●	●	●	—	—	
	03	3/8	—	●	●	—	—	
	04	1/2	—	—	●	●	—	
	06	3/4	—	—	—	●	●	
④ Option	a Mounting	-	Without mounting option	●	●	●	●	●
		B	With bracket	●	●	●	●	●
		H	With set nut (for panel fitting)	●	●	●	—	—
④ Option	b Pressure gauge	-	Round type pressure switch (with limit indicator)	●	●	●	●	●
		G	Round type pressure switch (with limit indicator)	●	●	●	●	●
⑤ Semi-standard	c Exhaust mechanism	-	Relieving type	●	●	●	●	●
		N	Non-relieving type	●	●	●	●	●
⑤ Semi-standard	d Flow direction	-	Flow direction: Left to right	●	●	●	●	●
		R	Flow direction: Right to left	●	●	●	●	●
⑤ Semi-standard	e Handle facing	-	Downward facing handle	●	●	●	●	●
		Y	Upward facing handle	●	●	●	●	●
⑤ Semi-standard	f Pressure unit	-	Name plate and pressure gauge in SI units: MPa	●	●	●	●	●
		Z	Name plate and pressure gauge in imperial units (PSI)	○	○	○	○	○

- Note 1) Option B, G and H are not assembled and are supplied loose at the time of shipment.
- Note 2) Assembly includes a bracket and set nuts (the AR20 to AR40) Includes 2 mounting screws for the AR50 and AR60
- Note 3) For thread type: NPT. This product is for overseas use only according to the new Measurement Law. (The SI unit type is provided for use in Japan.)
- Note 4) ○: For thread type: NPT only

# Modular Type Lubricator *Series AL*

Lubricator Series AL	Model	Port size	Option
 <p data-bbox="167 896 470 929">Page 51 through to 56</p>	<b>AL10</b>	M5	Bracket
	<b>AL20</b>	1/8, 1/4	
	<b>AL30</b>	1/4, 3/8	
	<b>AL40</b>	1/4, 3/8, 1/2	
	<b>AL40-06</b>	3/4	
	<b>AL50</b>	3/4, 1	
	<b>AL60</b>	1	

# Lubricator

# AL10 to AL60

JIS Symbol

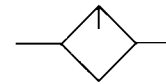

AL20



AL40

## How to Order

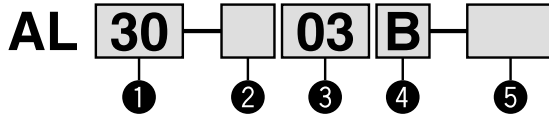

- Option / Semi-standard: Select one each for a to d.
- Option / Semi-standard symbol: When more than one specification is required, indicate in ascending alphanumeric order.  
Example) AL30-03B-2R

		Symbol	Description	① Body size						
				10	20	30	40	50	60	
②	Thread type	-	Metric thread (M5)	●	—	—	—	—	—	
		N	Rc	—	●	●	●	●	●	
		F	NPT	—	●	●	●	●	●	
			G	—	●	●	●	●	●	
		+								
③	Port size	M5	M5	●	—	—	—	—	—	
		01	1/8	—	●	—	—	—	—	
		02	1/4	—	●	●	—	—	—	
		03	3/8	—	—	●	●	—	—	
		04	1/2	—	—	—	●	—	—	
		06	3/4	—	—	—	—	●	—	
		10	1	—	—	—	—	—	●	
		+								
④	Option (Mounting)	-	Without mounting option	●	●	●	●	●	●	
		B <sup>Note 1)</sup>	With bracket	—	●	●	●	●	●	
		+								
⑤	a	Bowl	-	Polycarbonate bowl	●	●	●	●	●	●
			1	1000 cm <sup>3</sup> tank	—	—	△ <sup>Note 2)</sup>	△ <sup>Note 2)</sup>	△ <sup>Note 2)</sup>	△ <sup>Note 2)</sup>
			10	1000 cm <sup>3</sup> tank with level switch (lowest limit ON)	—	—	△ <sup>Note 2)</sup>	△ <sup>Note 2)</sup>	△ <sup>Note 2)</sup>	△ <sup>Note 2)</sup>
			11	1000 cm <sup>3</sup> tank with level switch (lowest limit OFF)	—	—	△ <sup>Note 2)</sup>	△ <sup>Note 2)</sup>	△ <sup>Note 2)</sup>	△ <sup>Note 2)</sup>
			2	Metal bowl	●	●	●	●	●	●
			6	Nylon bowl	●	●	●	●	●	●
			8	Metal bowl with level gauge	—	—	●	●	●	●
			C	With bowl guard	—	●	—	—	—	—
	6C	Nylon bowl with bowl guard	—	●	—	—	—	—		
			+							
	b	Lubricant port	-	Without drain cock	●	●	●	●	●	●
			3	With drain cock	●	●	●	●	●	●
			3W	Drain cock with barb fitting: For ø6 x ø4 nylon tube	—	—	●	●	●	●
		+								
c	Flow direction	-	Flow direction: Left to right	●	●	●	●	●	●	
		R	Flow direction: Right to left	●	●	●	●	●	●	
		+								
d	Pressure unit	-	Name plate and pressure gauge in SI units: MPa	●	●	●	●	●	●	
		Z <sup>Note 3)</sup>	Name plate and pressure gauge in imperial units (PSI, °F)	○ <sup>Note 4)</sup>	○ <sup>Note 4)</sup>	○ <sup>Note 4)</sup>	○ <sup>Note 4)</sup>	○ <sup>Note 4)</sup>	○ <sup>Note 4)</sup>	

Note 1) Option B is not assembled and is supplied loose at the time of shipment.

Note 2) △: Dedicated lubricant discharge function is equipped, and the combination with options 3 or 3W from semi-standard section b is not available.

Note 3) For thread type: M5 and NPT. This product is for overseas use only according to the new Measurement Law. (The SI unit type is provided for use in Japan.)

Note 4) ○: For thread type: M5 and NPT only

## Standard Specifications

Model	AL10	AL20	AL30	AL40	AL40-60	AL50	AL60
Port size	M5	1/8, 1/4	1/4, 3/8	1/4, 3/8, 1/2	3/4	3/4, 1	1
Fluid	Air						
Proof pressure	1.5 MPa						
Maximum operating pressure	1.0 MPa						
Ambient and fluid temperature	-5 to 60°C (with no freezing)						
Minimum dripping flow rate <sup>Note)</sup> [ $\mu$ /min (ANR)]	4	15	1/4: 30 3/8: 40	1/4: 30 3/8: 40 1/2: 50	50	190	220
Oil capacity (cm <sup>3</sup> )	7	25	55	135			
Recommended lubricant	Class 1 turbine oil (ISO VG32)						
Bowl material	Polycarbonate						
Bowl guard	—	Semi-standard	Standard				
Weight (kg)	0.07	0.2	0.24	0.47	0.52	1.06	1.13

Notes) • The flow rate is 5 drips or greater/min under the following conditions: Inlet pressure of 0.5 MPa; Class 1 turbine oil (ISO VG32); Temperature at 20°C; Oil adjustment valve fully opened.  
• Use air consumption flow rate for minimum dripping flow rate.

## Option / Part No.

Option \ Model	AL10	AL20	AL30	AL40	AL40-60	AL50	AL60
Bracket assembly <sup>Note)</sup>	—	AF20P-050AS	AF30P-050AS	AF40P-050AS	AF40P-070AS	AF50P-050AS	AF50P-050AS

The part number for bracket assembly for 1000 cm<sup>3</sup> is AF50P-050AS (applicable to the AL30 to AL60).  
Note) Assembly includes a bracket and 2 mounting screws

# Series AL10 to AL60

## Flow Characteristics (Representative values)

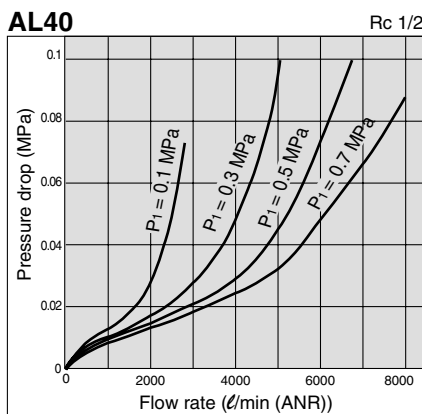
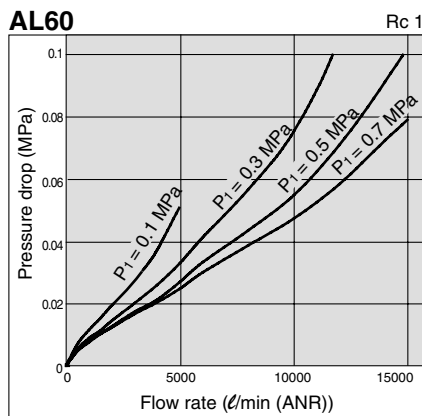
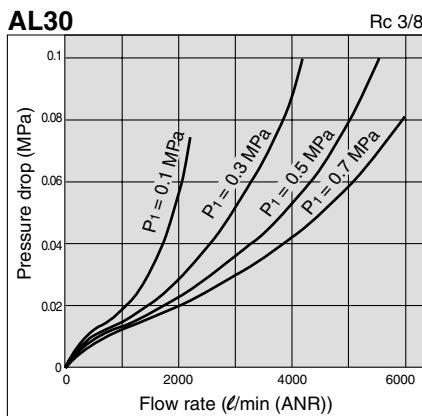
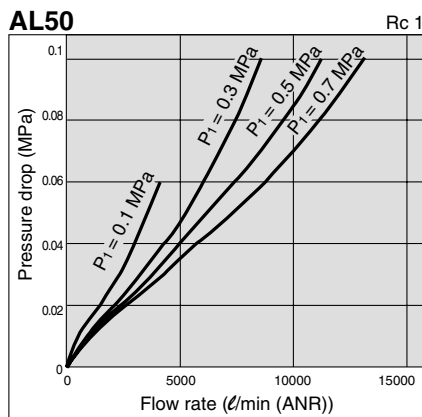
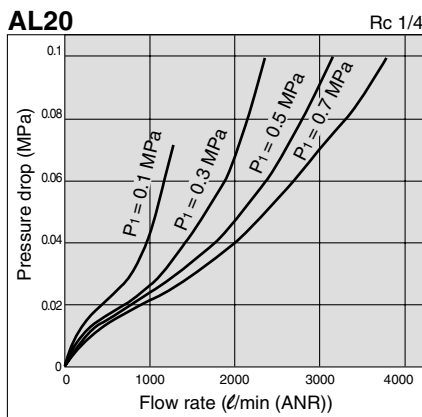
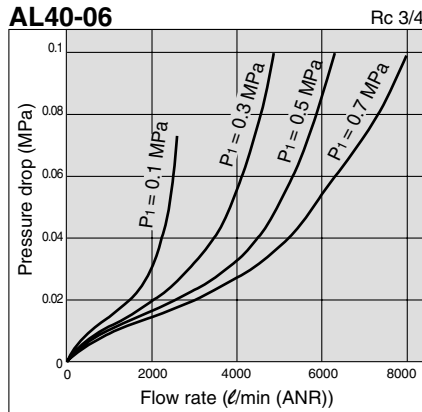
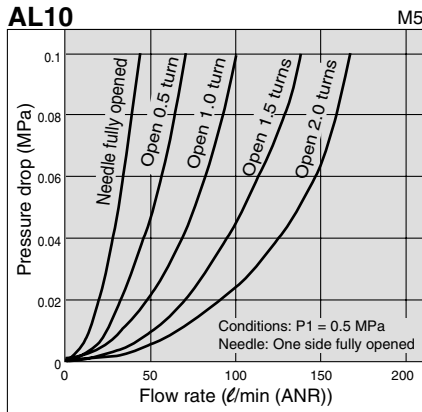

## Working Principle: AL10 Type

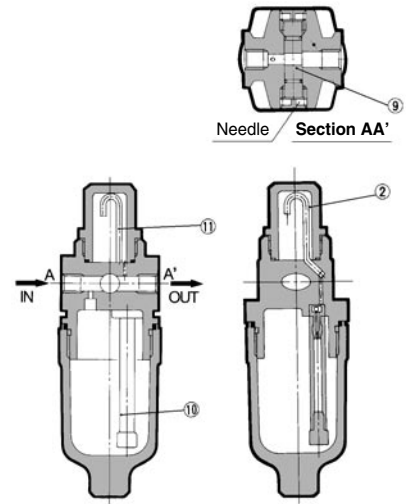

A portion of the air introduced from the IN side pressurises the lubricant inside the bowl. The remainder of the air passes through the needles ⑨, and flows to the OUT side. The pressure differential between the inside of the bowl and the inside of sight dome ②, causes the lubricant inside the bowl into oil passage ⑩. The lubricant drips from dripping tube ⑪, and lubricates the OUT side. The amount of lubricant is adjusted by needle ⑨, on the front face. Turning the needle clockwise increases the amount of the lubricant, and turning it counterclockwise until fully opened shuts off the lubricant. The needle on the side that is not used should be left fully opened.

### ⚠ Specific Product Precautions

Be sure to read this before handling. Refer to "Precautions for Handling Pneumatic Devices" (M-03-E3A) for Safety Instructions and F.R.L. Unit Precautions.

### Selection

### ⚠ Warning

1. Do not introduce air from the outlet side as this can damage the damper.

### ⚠ Caution

1. Use a check valve (the AKM series) to prevent back flow of the lubricant when re-directing the air flow before the lubricator.

### Maintenance

### ⚠ Warning

1. For the AL10/20 type, replenish the lubricant after releasing the inlet pressure. Lubrication cannot take place under a pressurised condition.

### ⚠ Caution

1. Check the dripping amount once a day. Drip failure can cause damage to the components that need lubrication.

## Construction

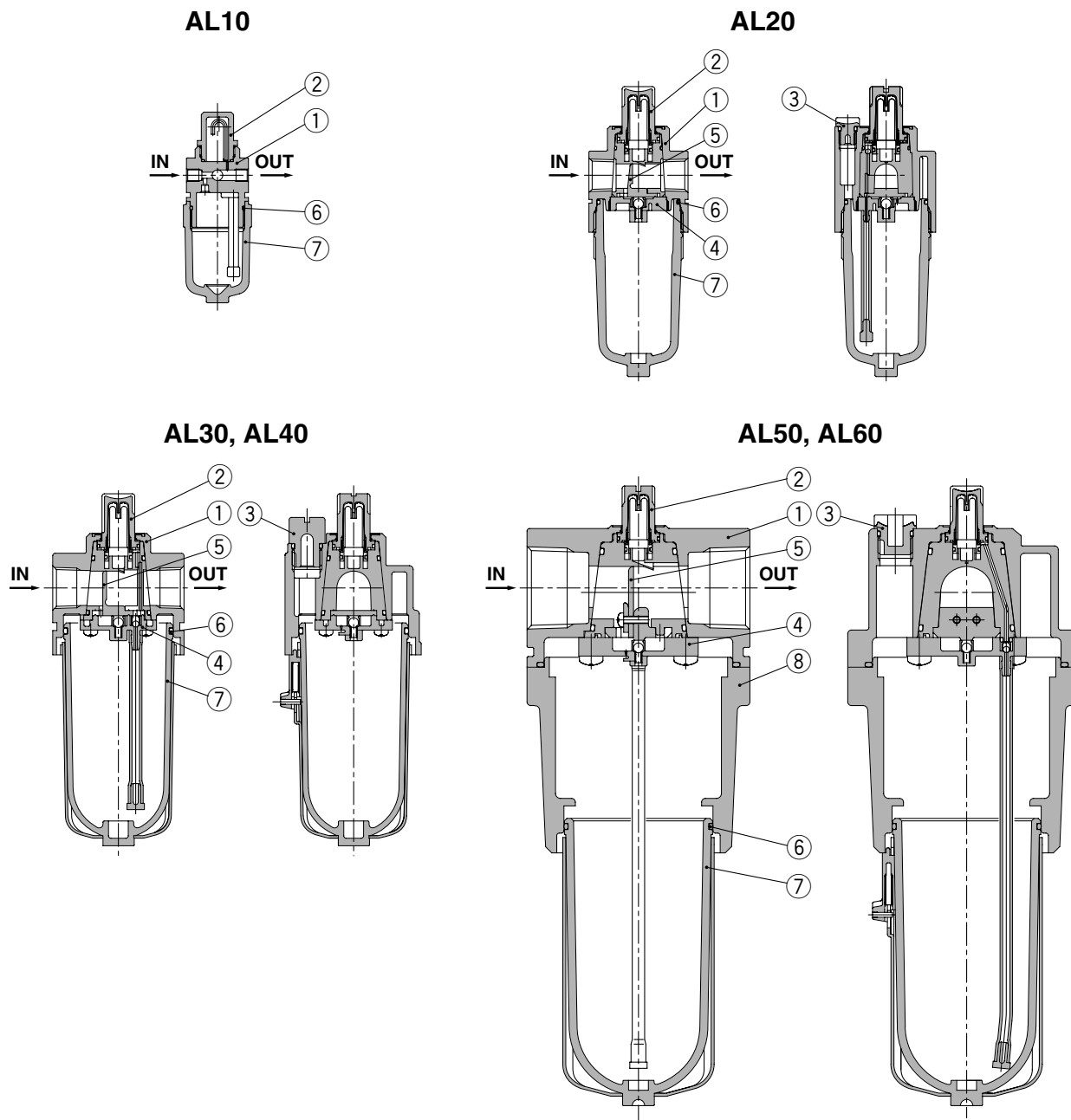

### Component Parts

No.	Description	Material	Model	Colour
1	Body	Zinc die-cast	AL10, AL20	Platinum silver
		Aluminum die-cast	AL30 to AL60	
8	Housing	Aluminum die-cast	AL50, AL60	Platinum silver

### Replacement Parts

No.	Description	Material	Part no.						
			AL10	AL20	AL30	AL40	AL40-06	AL50	AL60
2	Sight dome assembly	Polycarbonate	AL10P-080AS	AL20P-080AS					
3	Lubrication plug assembly	—	—	AL20P-060AS	AL30P-060AS	AL40P-060AS			
4	Damper retainer assembly <sup>Note 1)</sup>	—	—	AL20P-030AS	AL30P-030AS	AL40P-030AS		AL50P-030AS	AL60P-030AS
5	Damper (assembly)	Synthetic resin	—	AL20P-040S	AL30P-040S	AL40P-040S		AL50P-040AS	AL60P-040AS
6	Bowl O-ring	NBR	C1SFP-260S	C2SFP-260S	C3SFP-260S	C4SFP-260S			
7	Bowl assembly <sup>Note 2)</sup>	Polycarbonate	C1SL	C2SL	C3SL <sup>Note 3)</sup>	C4SL <sup>Note 3)</sup>			

Note 1) Add "-1" at the end of the part number when ordering a damper retainer assembly for 1000 cm<sup>3</sup>. Example) AL30P-030AS-1

Note 2) Includes O-Ring. Please contact SMC regarding the bowl assembly supply for PSI and °F unit specifications.

Note 3) Bowl assembly for the AL30 to AL60 comes with a bowl guard (steel band material).

# Series AL10 to AL60

## Dimensions

### AL10

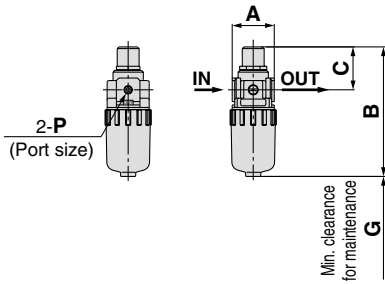

### AL20

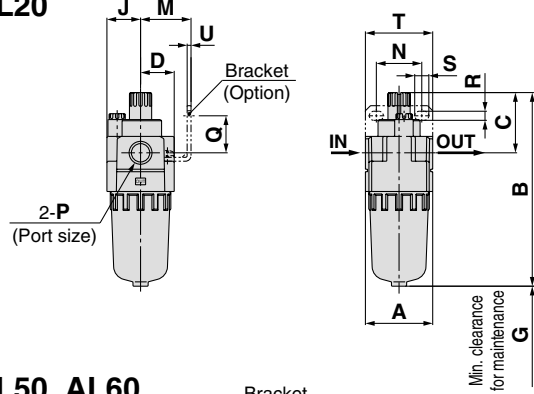

### AL30, AL40

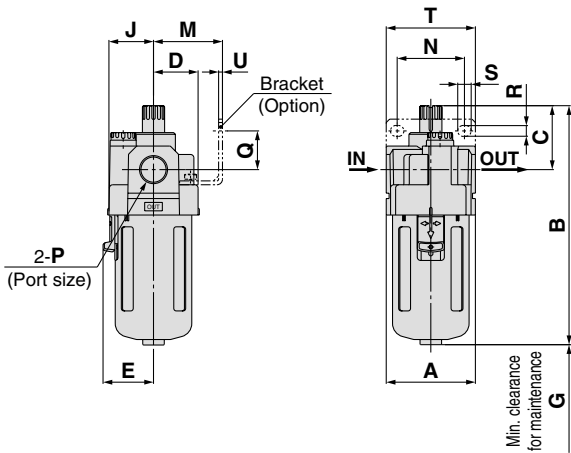

### AL50, AL60

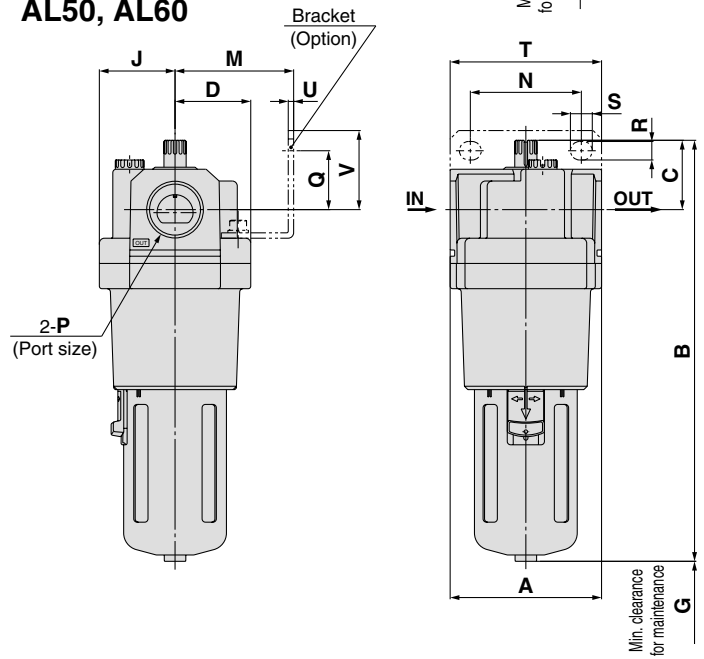

Applicable model Optional/Semi-standard specifications	AL10, AL20				AL30 to AL60			
	With drain cock	Metal bowl with drain cock	Metal bowl	With drain cock	Metal bowl with level gauge	Metal bowl with drain cock	Metal bowl with drain cock & level gauge	Drain cock with barb fitting
Dimensions								

Model	Standard specifications								Optional specifications Bracket mounting size						
	P	A	B	C	D	E	G	J	M	N	Q	R	S	T	U
AL10	M5	25	77	26	12.5	—	35	12.5	—	—	—	—	—	—	—
AL20	1/8, 1/4	40	115	36	20	—	60	20	30	27	22	5.4	8.4	40	2.3
AL30	1/4, 3/8	53	142	38	26.5	30	80	26.5	41	40	23	6.5	8	53	2.3
AL40	1/4, 3/8, 1/2	70	176	40	35	38	110	35	50	54	26	8.5	10.5	70	2.3
AL40-06	3/4	75	176	38	45	38	110	45	50	54	25	8.5	10.5	70	2.3
AL50	3/4, 1	90	250	41	45	45	110	45	70	66	35	11	13	90	3.2
AL60	1	95	268	45	47.5	47.5	110	47.5	70	66	35	11	13	90	3.2

Model	Semi-standard specifications					
	With drain cock	With barb fitting	Metal bowl	Metal bowl with drain cock	Metal bowl with level gauge	Metal bowl with drain cock & level gauge
	B	B	B	B	B	B
AL10	85	—	82	85	—	—
AL20	123	—	121	124	—	—
AL30	153	161	142	166	162	186
AL40	187	195	176	200	196	220
AL40-06	187	195	176	200	196	220
AL50	261	269	250	274	270	294
AL60	279	287	268	292	288	312

## Dimensions



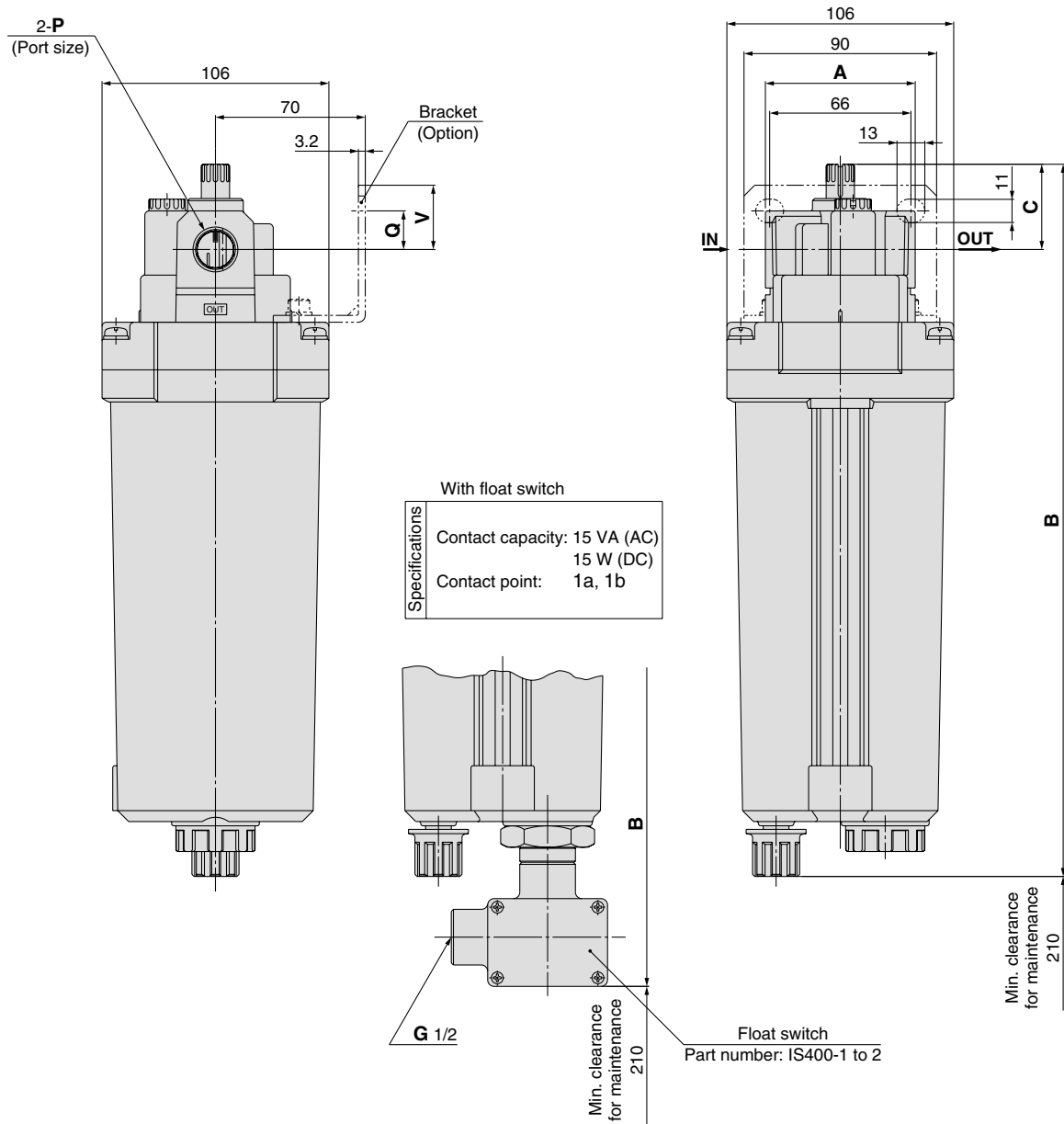

Semi-standard specifications: 1000 cm<sup>3</sup> tank



Model	P	A	B	C	Bracket mounting size		With float switch B
					Q	V	
AL30	1/4, 3/8	53	324	38	25	—	374
AL40	1/4, 3/8, 1/2	70	333	40	18	—	383
AL40-06	3/4	75	333	38	16	—	383
AL50	3/4, 1	90	332	41	35	47	382
AL60	1	95	335	45	35	47	385



# Modular Type Filter Regulators Series AW

Filter Regulator Series AW	Model	Port size	Option
 <p>Page 59 through to 66</p>	AW10	M5	Bracket Float type auto drain Square embedded type pressure gauge (except for AW10) Digital pressure switch (except for AW10) Round type pressure gauge Panel mount
	AW20	1/8, 1/4	
	AW30	1/4, 3/8	
	AW40	1/4, 3/8, 1/2	
	AW40-06	3/4	
	AW60	3/4, 1	
 <p>Page 59 through to 66</p>	AW20K	1/8, 1/4	
	AW30K	1/4, 3/8	
	AW40K	1/4, 3/8, 1/2	
	AW40K-06	3/4	
	AW60K	3/4, 1	
 <p>Page 67 through to 72</p>	AWM20	1/8, 1/4	
	AWM30	1/4, 3/8	
	AWM40	1/4, 3/8, 1/2	
 <p>Page 67 through to 72</p>	AWD20	1/8, 1/4	
	AWD30	1/4, 3/8	
	AWD40	1/4, 3/8, 1/2	

# Filter Regulator

## AW10 to AW60

### Filter Regulator with Backflow Mechanism

## AW20K to AW60K

JIS Symbol  
Filter Regulator

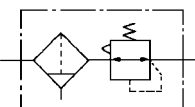

Symbol  
Filter Regulator with  
Backflow Mechanism

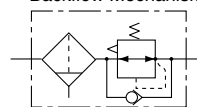

- Integrated filter and regulator units save space and require less piping.
- With the backflow function it incorporates a mechanism to exhaust the air pressure in the outlet side reliably and quickly.

Example)

When the air supply is cut off and releasing the inlet pressure to the atmosphere, the residual pressure release of the outlet side can be ensured for a safety purpose.

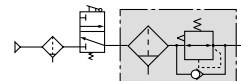

### How to Order

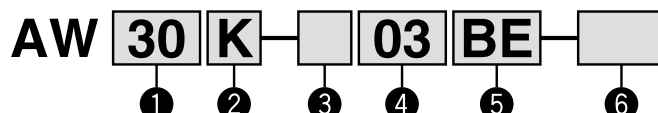

- Option / Semi-standard: Select one each for a to i.
  - Option / Semi-standard symbol: Enter them alphanumerically.
- Example) AW30K-03BE-1N

	Symbol	Description	①						
			Body size						
			10	20	30	40	60		
②	-	Without backflow mechanism	●	●	●	●	●		
	K <small>Note 1)</small>	With backflow mechanism	—	●	●	●	●		
+									
③	-	Metric thread (M5)	●	—	—	—	—		
	-	Rc	—	●	●	●	●		
	N <small>Note 2)</small>	NPT	—	●	●	●	●		
	F <small>Note 3)</small>	G	—	●	●	●	●		
+									
④	M5	M5	●	—	—	—	—		
	01	1/8	—	●	—	—	—		
	02	1/4	—	●	●	●	—		
	03	3/8	—	—	●	●	—		
	04	1/2	—	—	—	●	—		
	06	3/4	—	—	—	●	●		
+									
⑤ Option	a	-	Without mounting option	●	●	●	●	●	
		B <small>Note 5)</small>	With bracket	●	●	●	●	●	
		H	With set nut (for panel fitting)	●	●	●	●	—	
	+								
	b	-	Without auto drain	●	●	●	●	●	
		C	Float type auto drain (N.C.)	●	●	●	●	●	
		D	Float type auto drain (N.O.)	—	—	●	●	●	
	+								
	c	Pressure gauge	-	Without pressure gauge	●	●	●	●	●
			E	Square embedded type pressure gauge (with limit indicator)	—	●	●	●	●
			G	Round type pressure switch (without limit indicator)	●	—	—	—	—
				Round type pressure switch (with limit indicator)	—	●	●	●	●
Digital pressure switch		E1 <small>Note 6)</small>	Output: NPN output / Electrical entry: Wiring bottom entry	—	●	●	●	●	
		E2 <small>Note 6)</small>	Output: NPN output / Electrical entry: Wiring top entry	—	●	●	●	●	
+									
⑥ Semi-standard	d	-	0.05 to 0.85 MPa set	●	●	●	●	●	
		1 <small>Note 7)</small>	0.02 to 0.2 MPa set	●	●	●	●	●	
	+								
	e	-	Polycarbonate bowl	●	●	●	●	●	
		2	Metal bowl	●	●	●	●	●	
		6	Nylon bowl	●	●	●	●	●	
		8	Metal bowl with level gauge	—	—	●	●	●	
		C	With bowl guard	—	●	—	—	—	
		6C	Nylon bowl with bowl guard	—	●	—	—	—	

# Filter Regulator *Series AW10 to AW60*

# Filter Regulator with Backflow Mechanism *Series AW20K to AW60K*



AW20/AW20K    AW40/AW40K

		Symbol	Description	①					
				Body size					
				10	20	30	40	60	
6	f	Drain port <sup>Note 8)</sup>	-	With drain cock	●	●	●	●	●
			J <sup>Note 9)</sup>	Drain guide 1/8	—	●	—	—	—
				Drain guide 1/4	—	—	●	●	●
			W <sup>Note 10)</sup>	Drain cock with barb fitting: For ø6 x ø4 nylon tube	—	—	●	●	●
	+								
	g	Exhaust mechanism	-	Relieving type	●	●	●	●	●
			N	Non-relieving type	●	●	●	●	●
	+								
	h	Flow direction	-	Flow direction: Left to right	●	●	●	●	●
			R	Flow direction: Right to left	●	●	●	●	●
	+								
	i	Pressure unit	-	Name plate, caution plate for bowl, and pressure gauge in SI units: MPa	●	●	●	●	●
Z <sup>Note 11)</sup>			Name plate, caution plate for bowl, and pressure gauge in imperial units (PSI, °F)	○ <sup>Note 13)</sup>	○ <sup>Note 13)</sup>	○ <sup>Note 13)</sup>	○ <sup>Note 13)</sup>	○ <sup>Note 13)</sup>	
ZA <sup>Note 12)</sup>			Digital pressure switch: With unit switching function	—	△ <sup>Note 14)</sup>	△ <sup>Note 14)</sup>	△ <sup>Note 14)</sup>	△ <sup>Note 14)</sup>	

Note 1) The AW10 comes with a backflow mechanism as a standard feature. (K is not available.) When using the backflow mechanism of the AW10 type, back flow may not occur with a set pressure of 0.15 MPa or less.

Note 2) Drain guide is NPT1/8 (applicable to the AW20(K) and NPT1/4 (applicable to the AW30(K) to AW60(K)). The exhaust port for auto drain comes with a ø3/8" One-touch fitting (applicable to the AW30(K) to AW60(K)).

Note 3) Drain guide is G1/8 (applicable to the AW20(K) and G1/4 (applicable to the AW30(K) to AW60(K)).

Note 4) Option B, G, and H are not assembled and are

supplied loose at the time of shipment.

Note 5) Assembly includes a bracket and set nuts (the AW10, AW20(K) to AW40(K)) Includes 2 mounting screws for the AW60(K)

Note 6) When choosing with H (panel mount), the installation space for the lead wire will be limited. In this case, select "wiring top entry" for the lead wire entry.

Note 7) The only difference from the standard specifications is the adjusting spring for the regulator. It does not restrict the setting of 0.2MPa or more. When the pressure gauge is attached, a 0.2 MPa pressure gauge will be fitted.

Note 8) Float type auto drain: The combination between C or D is not available with the drain port options.

Note 9) Without a valve function

Note 10) Metal bowl: The combination of 2 or 8 cannot be selected with W.

Note 11) For thread type: M5 and NPT. This product is for overseas use only according to the new Measurement Law. (The SI unit type is provided for use in Japan.) The digital pressure switch will be equipped with the unit switching function, setting to PSI initially.

Note 12) For options: E1, E2, E3, E4. This product is for overseas use only according to the new Measurement Law. (The SI unit is provided for use in Japan.)

Note 13) ○: For thread type: M5 and NPT only

Note 14) △: Combination available for options: E1, E2, E3, E4.

## Standard Specifications

Model	AW10	AW20(K)	AW30(K)	AW40(K)	AW40(K)-06	AW60(K)
Port size	M5	1/8, 1/4	1/4, 3/8	1/4, 3/8, 1/2	3/4	3/4, 1
Pressure gauge port size <sup>Note 1)</sup>	1/16 <sup>Note 2)</sup>	1/8		1/4		
Fluid	Air					
Ambient and fluid temperature <sup>Note 3)</sup>	-5 to 60°C (with no freezing)					
Proof pressure	1.5 MPa					
Maximum operating pressure	1.0 MPa					
Set pressure range	0.05 to 0.7 MPa	0.05 to 0.85 MPa				
Relief pressure	Set pressure + 0.05 MPa <sup>Note 4)</sup> [at relief flow rate of 0.1 ℓ/min (ANR)]					
Nominal filtration rating	5 μm					
Drain capacity (cm <sup>3</sup> )	2.5	8	25	45	45	45
Bowl material	Polycarbonate					
Bowl guard	—	Semi-standard	Standard			
Construction	Relieving type					
Weight (kg)	0.09	0.32	0.40	0.72	0.75	2.00

Note 1) Pressure gauge connection threads are not available for units with a square embedded type pressure gauge (the AW20(K) to AW60(K)).

Note 2) Use a bushing (part no:131368) when connecting the R 1/8 pressure gauge to the R 1/16.

Note 3) -5 to 50°C for the products with the digital pressure switch

Note 4) Not applicable for AW10.

# Series AW10 to AW60

# Series AW20K to AW60K

## Option / Part No.

Option		Model	AW10	AW20(K)	AW30(K)	AW40(K)	AW40(K)-06	AW60(K)	
<b>Bracket assembly</b> <sup>Note 1)</sup>			AR10P-270AS	AW20P-270AS	AR30P-270AS	AR40P-270AS		AW60P-270AS <sup>Note 6)</sup>	
<b>Set nut</b>			AR10P-260S	AR20P-260S	AR30P-260S	AR40P-260S		— <sup>Note 7)</sup>	
<b>Pressure gauge</b>	<b>Round type</b> <sup>Note 2)</sup>	<b>Standard</b>	G27-10-R1	G36-10-□01		G46-10-□02			
		<b>0.02 to 0.2 MPa set</b>	G27-10-R1 <sup>Note 2)</sup>	G36-2-□01		G46-2-□02			
	<b>Square embedded type</b> <sup>Note 4)</sup>	<b>Standard</b>	—	GC3-10AS [GC3P-010AS (Pressure gauge cover only)]					
		<b>0.02 to 0.2 MPa set</b>	—	GC3-2AS [GC3P-010AS (Pressure gauge cover only)]					
<b>Digital pressure switch</b> <sup>Note 5)</sup>	<b>NPN output / Wiring bottom entry</b>		—	ISE35-N-25-MLA [ISE35-N-25-M (Switch body only)]					
	<b>NPN output / Wiring top entry</b>			ISE35-R-25-MLA [ISE35-R-25-M (Switch body only)]					
	<b>PNP output / Wiring bottom entry</b>			ISE35-N-65-MLA [ISE35-N-65-M (Switch body only)]					
	<b>PNP output / Wiring top entry</b>			ISE35-R-65-MLA [ISE35-R-65-M (Switch body only)]					
<b>Float type auto drain</b> <sup>Note 8)</sup>		<b>N.O.</b>	—	—	AD38	AD48			
		<b>N.C.</b>	AD17	AD27	AD37	AD47			

Note 1) Assembly includes a bracket and set nuts

Note 2) □ in part numbers for a round pressure gauge indicates a type of connection thread. No indication is necessary for R; however, indicate N for NPT. Please contact SMC regarding the connection thread NPT and pressure gauge supply for PSI unit specifications.

Note 3) Standard pressure gauge

Note 4) Includes one O-ring and 2 mounting screws. [ ]: Pressure gauge cover only

Note 5) Lead wire with connector (2 m), adaptor, lock pin, O-ring (1 pc.), mounting screw (2 pcs.) are attached. [ ]: Switch body only. Also, regarding how to order the digital pressure switch, please refer to page 73. A pressure switch adaptor assembly (AW60P-310AS) will be additionally required for the AW60(K) only. Use the attached mounting screw (M3 x 14) for mounting. The mounting screw (M3 x 7) attached to the digital pressure switch assembly will not be required.

Note 6) Assembly of a bracket and 2 mounting screws

Note 7) Please consult with SMC regarding the set nuts for the AW60(K).

Note 8) Minimum operating pressure: N.O. type—0.1 MPa; N.C. type—0.1 MPa (AD17/27) and 0.15 MPa (AD37/47). Please contact SMC for PSI and °F specifications.

## ⚠ Specific Product Precautions

Be sure to read this before handling. Refer to “Precautions for Handling Pneumatic Devices” (M-03-E3A) for Safety Instructions and F.R.L. Unit Precautions.

### Selection

#### ⚠ Warning

- Residual pressure disposal (outlet pressure removal) is not possible for the AW20 to AW60 even though the inlet pressure is exhausted. When the residual pressure disposal is performed, use the regulator with backflow mechanism (the AW20K to AW60K).

### Maintenance

#### ⚠ Warning

- Replace the element every 2 years or when the pressure drop becomes 0.1 MPa, whichever comes first, to prevent damage to the element.

### Mounting and Adjustment

#### ⚠ Warning

- Set the regulator while verifying the displayed values of the inlet and outlet pressure gauges. Turning the regulator knob excessively can cause damage to the internal parts.
- The pressure gauge included with regulators for 0.02 to 0.2 MPa setting is for up to 0.2 MPa use only (except for the AR10). Exceeding 0.2 MPa of pressure can damage the gauge.
- Do not use tools on the pressure regulator knob as this may cause damage. It must be operated manually.

#### ⚠ Caution

- Be sure to unlock the knob before adjusting the pressure and lock it after setting the pressure. Failure to follow this procedure can cause damage to the knob and the outlet pressure may fluctuate.
  - Pull the pressure regulator knob to unlock. (You can visually verify this with the “orange mark” that appears in the gap.)
  - Push the pressure regulator knob to lock. When the knob is not easily locked, turn it left and right a little and then push it (when the knob is locked, the “orange mark”, i.e., the gap will disappear).
- A knob cover is available to prevent careless operation of the knob. Refer to “Features 1” for details.

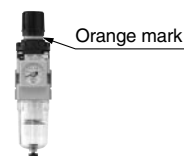

## Flow Characteristics (Representative values)

Condition: Inlet pressure 0.7 MPa

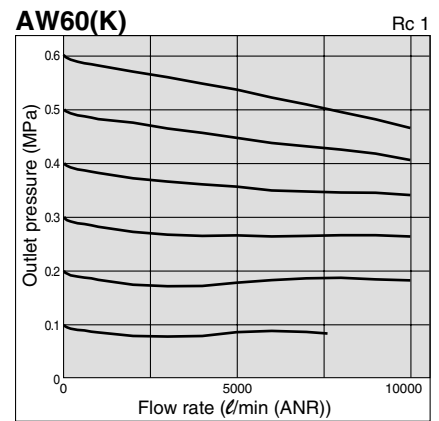
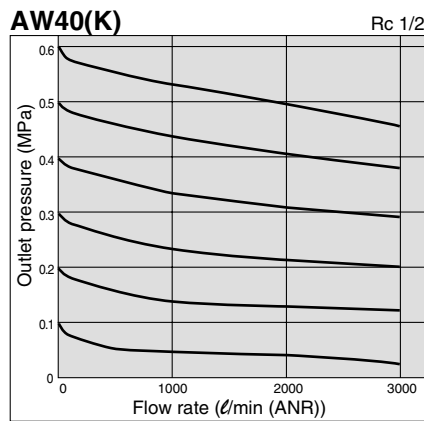
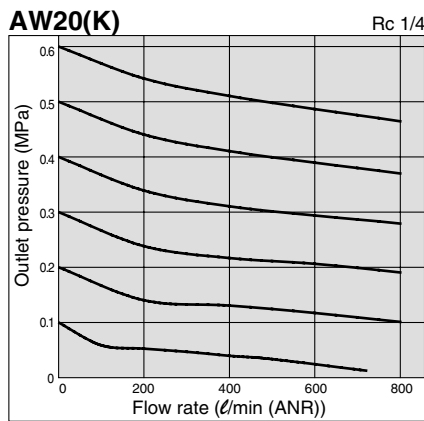
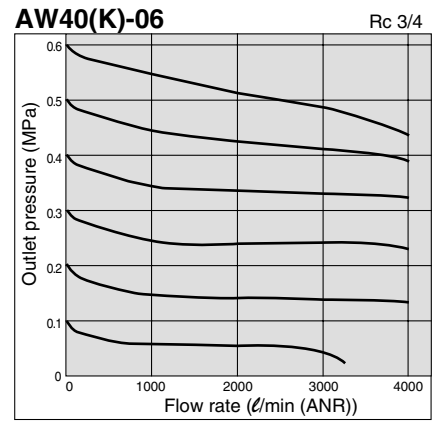
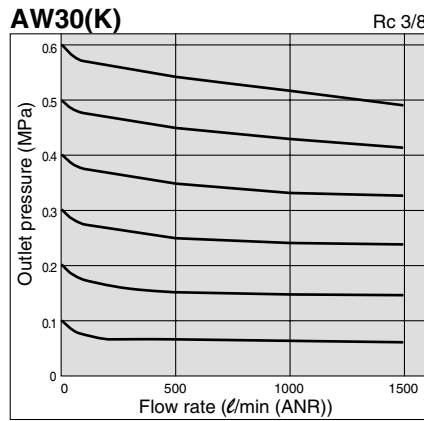
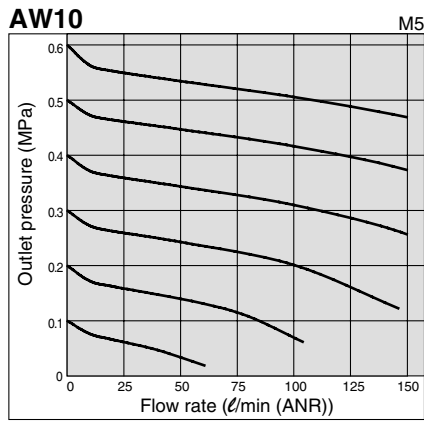

## Pressure Characteristics (Representative values)

Conditions: Inlet pressure 0.7 MPa, Outlet pressure 0.2 MPa, Flow rate 20 l/min (ANR)

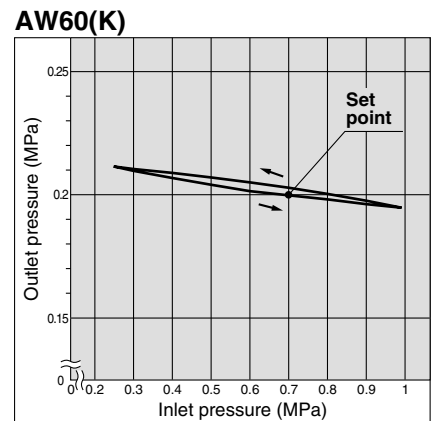
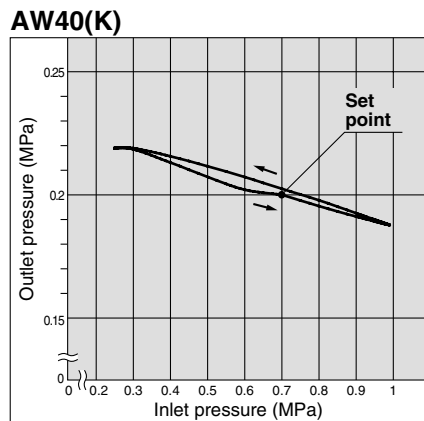
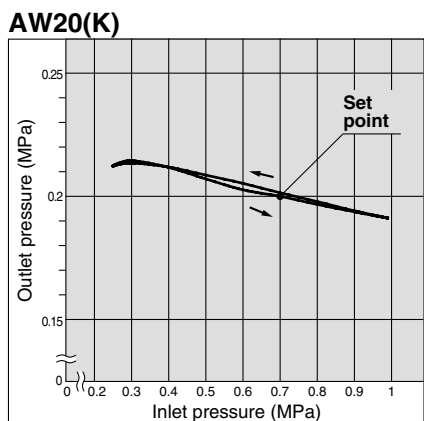
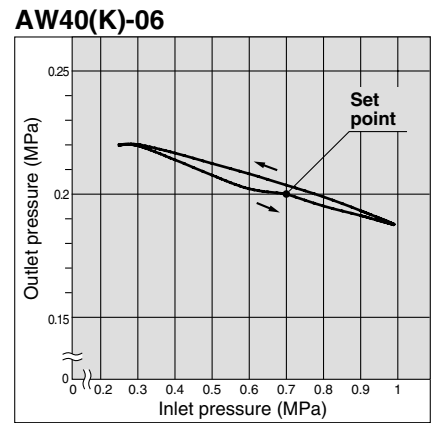
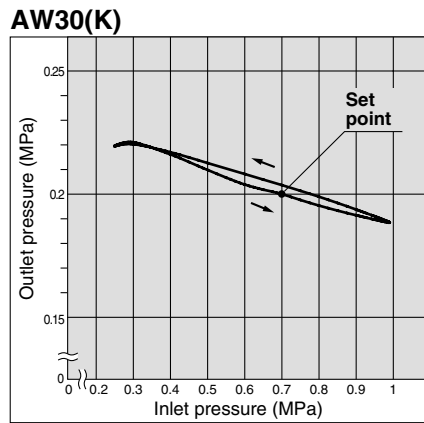
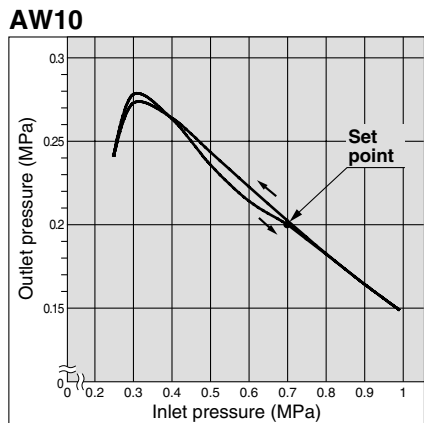

# Series AW10 to AW60

## Series AW20K to AW60K

### Construction

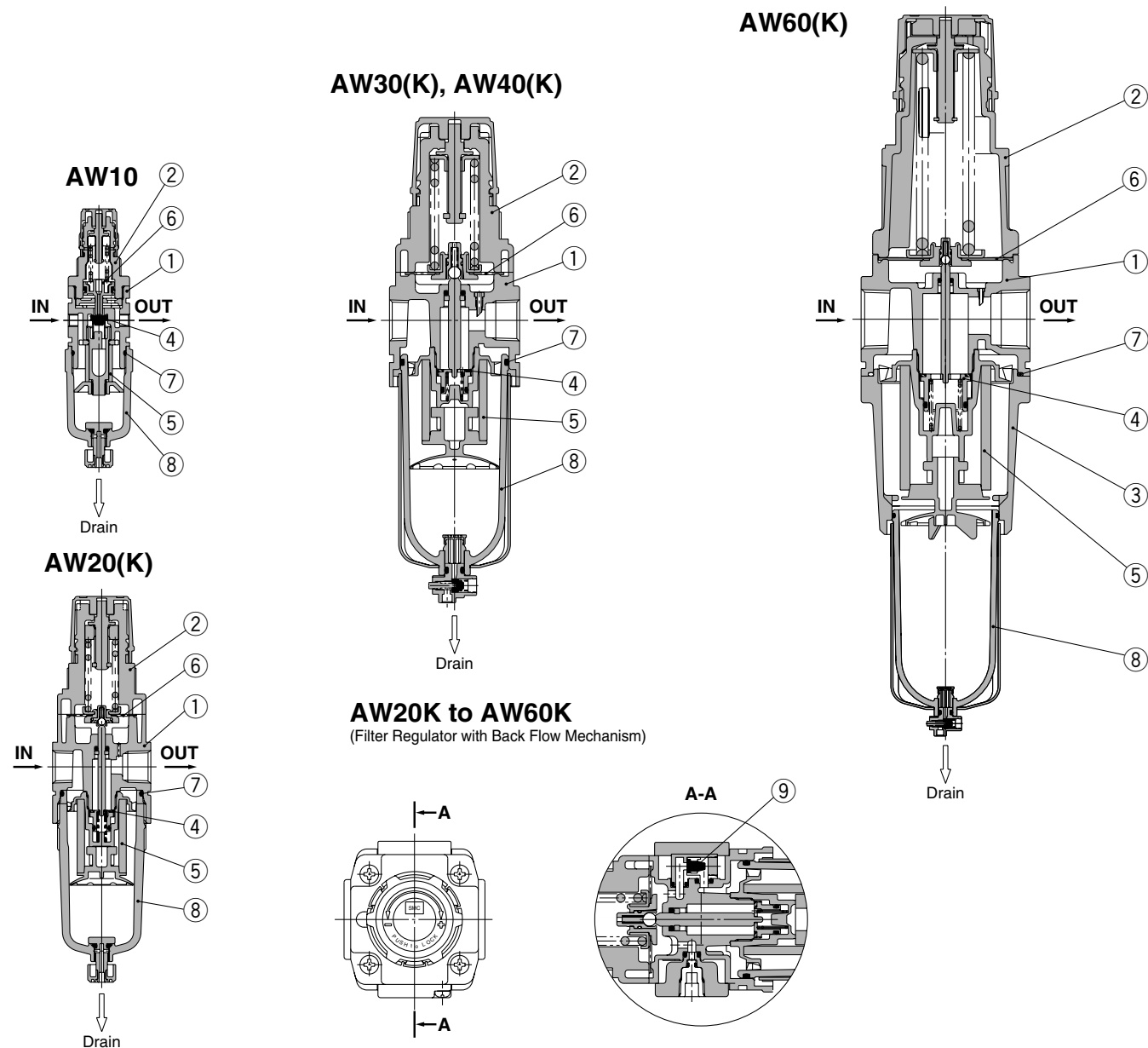

### Component Parts

No.	Description	Material	Model	Note
1	Body	Zinc die-cast	AW10, AW20	Platinum silver
		Aluminum die-cast	AW30 to AW60	
2	Bonnet	Polyacetal	AW10 to AW40	Black
		Aluminum die-cast	AW60	
3	Housing	Aluminum die-cast	AW60	Platinum silver

### Replacement Parts

No.	Description	Material	Part no.					
			AR10	AW20(K)	AW30(K)	AW40(K)	AR40(K)-60	AW60(K)
4	Valve assembly	Brass, HNBR	AR10P-090S	AW20P-340AS	AW30P-340AS	AW40P-340AS		AW60P-090AS
5	Filter element	Non-woven fabric	AF10P-060S	AF20P-060S	AF30P-060S	AF40P-060S		AW60P-060S
6	Diaphragm assembly	Weatherable NBR	AR10P-150AS <sup>Note 1)</sup>	AR20P-150AS	AR30P-150AS	AR40P-150AS		AR50P-150AS
7	Bowl O-ring	NBR	C1SFP-260S	C2SFP-260S	C3SFP-260S	C4SFP-260S		
8	Bowl assembly <sup>Note 2)</sup>	Polycarbonate	C1SF	C2SF	C3SF <sup>Note 3)</sup>	C4SF <sup>Note 3)</sup>		
9	Check valve assembly <sup>Note 4)</sup>	—	—	—	AR20KP-020AS			

Note 1) The AW10 is a piston type. Assembly includes a piston and a seal (KSY-P-13).

Note 2) Includes O-ring. Please contact SMC regarding the bowl assembly supply for PSI and °F unit specifications.

Note 3) Bowl assembly for the AW30(K) to AW60(K) comes with a bowl guard (steel band material).

Note 4) Check valve assembly is applicable for a filter regulator with backflow mechanism (the AW20K to AW60K) only.

Assembly includes a check valve cover, check valve body assembly and 2 screws

**Working Principle (Filter Regulator with Backflow Mechanism)**

**AW10**



When the inlet pressure is higher than the regulating pressure, the check valve operates as a normal regulator (Figure 1).

When the inlet pressure is shut off and exhausted, any inlet pressure applied to valve ① will be lost. The force for seating valve ① is the valve spring ② force only. When the valve ① is opened using the outlet force, the outlet pressure will be exhausted at the inlet side. (Figure 2)

When the set pressure is 0.15 MPa or less, valve ① may not open due to the force of valve spring ②.

**AW20K to AW60K**

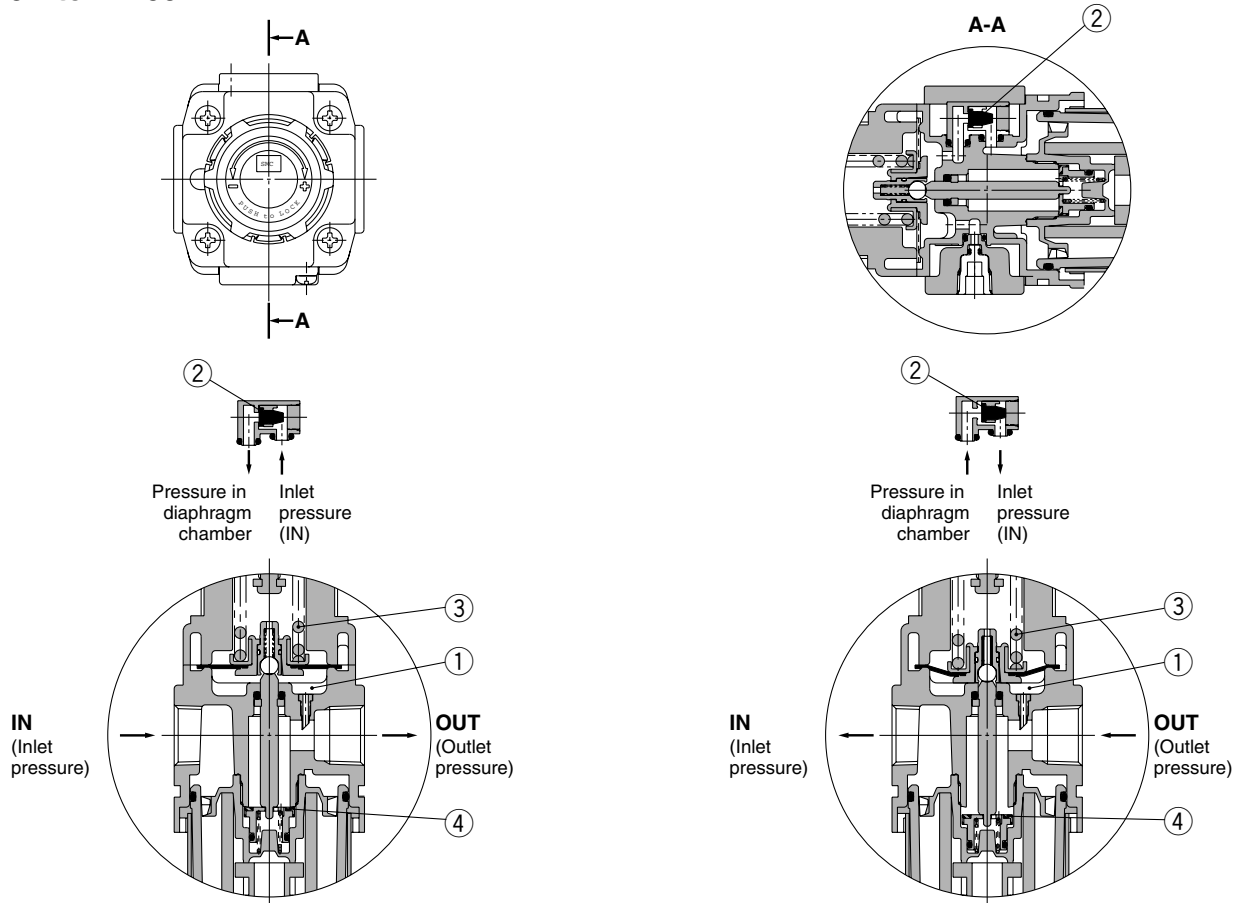

**Figure 1 Normal**

**Figure 2 Back flow**

When the inlet pressure is higher than the regulating pressure, the valve ② closes and operates as a normal regulator (Figure 1).

When the inlet pressure is shut off and released, check valve ② opens and the pressure in diaphragm chamber ① is released into the inlet side (Figure 2).

This lowers the pressure in diaphragm chamber ① and the force generated by pressure regulator spring ③ lifts the diaphragm. Valve ④ opens through the stem, and the outlet pressure is released to the inlet side (Figure 2).

# Series AW10 to AW60

## Series AW20K to AW60K

### Dimensions

#### AW10, AW20(K)

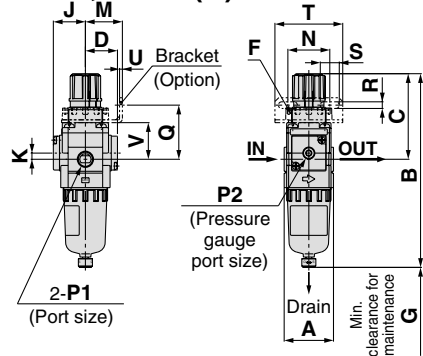

Panel fitting dimension

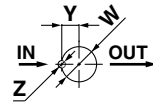

AW10, AW20(K): Max. 3.5

#### AW60(K)

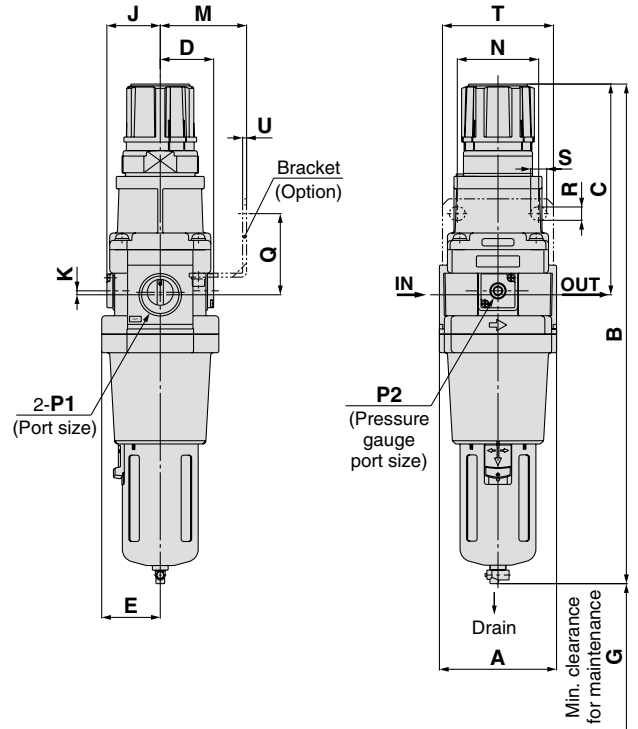

#### AW30(K) to AW40(K)-06

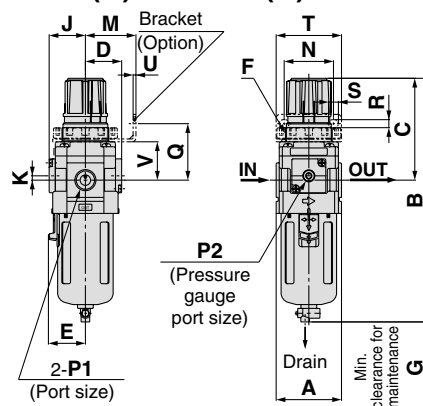

Panel fitting dimension

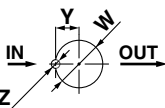

AW30(K): Max. 3.5  
AW40(K): Max. 5

Applicable model	AW20(K) to AW60(K)		AW10, AW20(K) to AW60(K)
Option	Square embedded type pressure gauge	Digital pressure switch	Round type pressure gauge
Dimensions	Centre of piping	Centre of piping	Centre of piping

Applicable model	AW10, AW20(K)		AW20(K)	AW30(K) to AW60(K)				
Optional/Semi-standard specifications	With auto drain (N.C.)	Metal bowl	With drain guide	With auto drain (N.O./N.C.)	Metal bowl	Metal bowl with level gauge	With drain guide	Drain cock with barb fitting
Dimensions	B M5	B	B 1/8 Width across flats 14	B ø10 One-touch fitting	B	B	B 1/4 Width across flats 17	B Barb fitting Applicable tubing: T0604

Model	Standard specifications												Optional specifications					
	P1	P2	A	B (Note)	C	D	E	F	G	J	K	H	J	H	J	H	J	
AW10	M5	1/16	25	108	48	12.5	—	M18 x 1	25	13	0	—	—	—	—	—	—	
AW20(K)	1/8, 1/4	1/8	40	160	73	26	—	M28 x 1	40	26	5	□28	27	□27.8	37.5	□37.5	63	
AW30(K)	1/4, 3/8	1/8	53	201	86	29.5	30	M38 x 1.5	55	29.5	3.5	□28	30.5	□27.8	41	□37.5	66	
AW40(K)	1/4, 3/8, 1/2	1/4	70	239	92	37.5	38	M42 x 1.5	80	37.5	1.5	□28	38.5	□27.8	49	□42.5	76	
AW40(K)-06	3/4	1/4	75	242	93	37.5	38	M42 x 1.5	80	37.5	1.2	□28	38.5	□27.8	49	□42.5	76	
AW60(K)	3/4, 1	1/4	95	409	175	43.5	47.5	—	20	43.5	3.2	□28	44.5	□27.8	61.5	□42.5	84	

Model	Optional specifications											Semi-standard specifications				
	Bracket mount					Panel mount						With auto drain	With barb fitting	With drain guide	Metal bowl	Metal bowl with level gauge
	M	N	Q	R	S	T	U	V	W	Y	Z	B	B	B	B	B
AW10	25	28	30	4.5	6.5	40	2	18	18.5	—	—	125	—	—	107	—
AW20(K)	30	34	44	5.4	15.4	55	2.3	30	28.5	14	6	177	—	164	160	—
AW30(K)	41	40	46	6.5	8	53	2.3	31	38.5	19	7	242	209	208	214	234
AW40(K)	50	54	54	8.5	10.5	70	2.3	35.5	42.5	21	7	278	247	246	252	272
AW40(K)-06	50	54	56	8.5	10.5	70	2.3	37	42.5	21	7	282	251	249	255	275
AW60(K)	70	66	66	11	13	90	3.2	—	—	—	—	448	417	416	422	442

Note) The total length of B dimension is the length when the filter regulator handle is unlocked.

# Filter Regulator AW20 to AW60 Made to Order



Please contact SMC for detailed dimensions, specifications, and lead times.



AW30-03-2-X425

## ① Special Temperature Environment

Special materials are used in the manufacturing of seals and resin parts to allow them to withstand various temperature conditions in cold or tropical (hot) climates.

### Specifications

Made-to-order part no.	-X430	-X440
Environment	Low temperature	High temperature
Ambient temperature (°C)	-30 to 60°C	-5 to 80°C
Fluid temperature (°C)	-5 to 60°C (with no freezing)	
Material	Rubber parts	Special NBR
	Main parts	FKM
	Metal (Aluminum die-cast), etc.	

### Applicable Model

Model	AW30	AW40	AW40-06	AW60
Port size	1/4, 3/8	1/4, 3/8, 1/2	3/4	3/4, 1

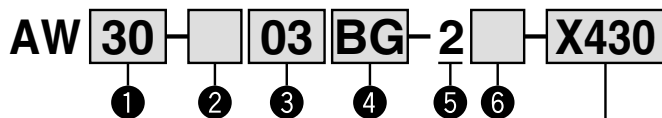

- Option / Semi-standard: Select one each for a to g.
  - Option / Semi-standard symbol: Enter them alphanumerically.
- Example) AW30-03BG-2N-X430

For high/low temperature	
X430	Low temperature
X440	High temperature

	Symbol	Description	① Body size			
			30	40	60	
② Thread type	-	Rc	●	●	●	
	N	NPT	●	●	●	
	F	G	●	●	●	
+						
③ Port size	02	1/4	●	●	—	
	03	3/8	●	●	—	
	04	1/2	—	●	—	
	06	3/4	—	●	●	
	10	1	—	—	●	
+						
④ Option	a Mounting	-	Without mounting option	●	●	●
		B	With bracket	●	●	●
		H	With set nut (for panel fitting)	●	●	—
+						
b Pressure gauge	-	Without pressure gauge	●	●	●	
	G	Round type pressure switch (without limit indicator)	●	●	●	
+						
⑤ Bowl	2	Metal bowl	●	●	●	
+						
⑥ Semi-standard	c Set pressure	-	0.05 to 0.85 MPa set	●	●	●
		1	0.02 to 0.2 MPa set	●	●	●
	+					
	d Drain port	-	With drain cock	●	●	●
		J	Drain guide 1/4	●	●	●
	+					
	e Exhaust mechanism	-	Relieving type	●	●	●
		N	Non-relieving type	●	●	●
	+					
	f Flow direction	-	Flow direction: Left to right	●	●	●
R		Flow direction: Right to left	●	●	●	
+						
g Pressure unit	-	Name plate, caution plate for bowl, and pressure gauge in SI units: MPa	●	●	●	
	Z	Name plate, caution plate for bowl, and pressure gauge in imperial units (PSI, °F)	○	○	○	

- Note 1) Option B, G and H are not assembled and are supplied loose at the time of shipment.
- Note 2) Assembly includes a bracket and set nuts (the AW30 to AW40). Includes 2 mounting screws for the AW60.
- Note 3) Only metal bowl 2 is available.
- Note 4) The only difference from the standard specifications is the adjusting spring for the regulator. It does not restrict the setting of 0.2 MPa or more. When the pressure gauge is attached, a 0.2 MPa pressure gauge will be fitted.
- Note 5) Without a valve function.
- Note 6) For thread type: NPT. This product is for overseas use only according to the new Measurement Law. (The SI unit type is provided for use in Japan.)
- Note 7) ○: For thread type: NPT only.

## ② High Pressure

Strong materials are used in the manufacturing of air filters intended for high pressure operation. Also, construction modification allows a wider regulating pressure range.

### Specifications

Made-to-order part no.	-X425
Proof pressure (MPa)	3.0
Maximum operating pressure (MPa)	2.0
Set pressure range (MPa)	0.1 to 1.6
Ambient and fluid temperature (°C)	-5 to 60°C (with no freezing)

### Applicable Model

Model	AW20	AW30	AW40	AW40-06	AW60
Port size	1/8, 1/4	1/4, 3/8	1/4, 3/8, 1/2	3/4	3/4, 1

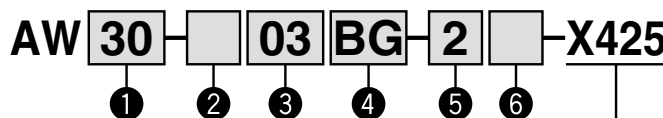

- Option / Semi-standard: Select one each for a to f.
  - Option / Semi-standard symbol: Enter them alphanumerically.
- Example) AW30-03BG-2N-X425

	Symbol	Description	① Body size				
			20	30	40	60	
② Thread type	-	Rc	●	●	●	●	
	N	NPT	●	●	●	●	
	F	G	●	●	●	●	
+							
③ Port size	01	1/8	●	—	—	—	
	02	1/4	●	●	—	—	
	03	3/8	—	●	—	—	
	04	1/2	—	—	●	—	
	06	3/4	—	—	●	●	
	10	1	—	—	—	●	
+							
④ Option	a Mounting	-	Without mounting option	●	●	●	●
		B	With bracket	●	●	●	●
		H	With set nut (for panel fitting)	●	●	—	—
+							
b Pressure gauge	-	Without pressure gauge	●	●	●	●	
	G	Round type pressure switch (with limit indicator)	●	●	●	●	
+							
⑤ Bowl	2	Metal bowl	●	●	●	●	
	8	Metal bowl with level gauge	—	●	●	●	
+							
⑥ Semi-standard	c Exhaust mechanism	-	Relieving type	●	●	●	●
		N	Non-relieving type	●	●	●	●
+							
d Drain port	-	With drain cock	●	●	●	●	
	J	Drain guide 1/8 Drain guide 1/4	●	—	—	—	
+							
e Flow direction	-	Flow direction: Left to right	●	●	●	●	
	R	Flow direction: Right to left	●	●	●	●	
+							
f Pressure unit	-	Name plate, caution plate for bowl, and pressure gauge in SI units: MPa	●	●	●	●	
	Z	Name plate, caution plate for bowl, and pressure gauge in imperial units (PSI, °F)	○	○	○	○	

- Note 1) Option B, G and H are not assembled and are supplied loose at the time of shipment.
- Note 2) Assembly includes a bracket and set nuts (the AW20 to AW40). Includes 2 mounting screws for the AW60.
- Note 3) Only metal bowl 2 and 8 are available.
- Note 4) Without a valve function.
- Note 5) For thread type: NPT. This product is for overseas use only according to the new Measurement Law. (The SI unit type is provided for use in Japan.)
- Note 6) ○: For thread type: NPT only.

# Mist Separator Regulator

# AWM20 to AWM40

# Micro Mist Separator Regulator

# AWD20 to AWD40

Symbol  
Mist Separator  
Regulator

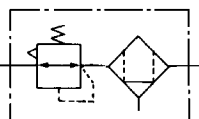

Symbol  
Micro Mist Separator  
Regulator

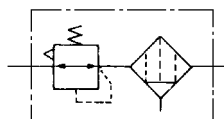

- The AWM series is made up of a regulator and a mist separator to provide optimum results in applications such as clean air blow operations. (Nominal filtration rating: 0.3 μm)
- The AWD series is made up of a regulator and a micro mist separator to provide optimum results in applications such as ultraclean air blow operations. (Nominal filtration rating: 0.01 μm)

## How to Order

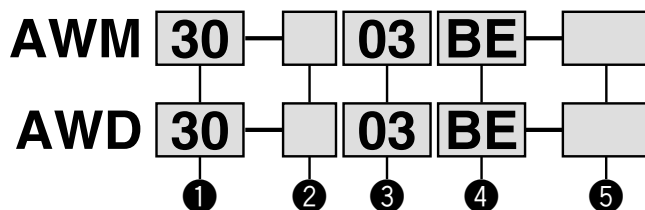

- Option / Semi-standard: Select one each for a to i.
- Option / Semi-standard symbol: When more than one specification is required, indicate in ascending alphanumeric order. Example) AWM30-03BE-1N

		Symbol	Description	①			
				Body size			
				20	30	40	
②	Thread type	-	Rc	●	●	●	
		<b>N</b> <small>Note 1)</small>	NPT	●	●	●	
		<b>F</b> <small>Note 2)</small>	G	●	●	●	
+							
③	Port size	<b>01</b>	1/8	●	—	—	
		<b>02</b>	1/4	●	●	●	
		<b>03</b>	3/8	—	●	●	
		<b>04</b>	1/2	—	—	●	
+							
④ Option	a	Mounting	-	Without mounting option	●	●	●
			<b>B</b> <small>Note 4)</small>	With bracket	●	●	●
			<b>H</b>	With set nut	●	●	●
	+						
	b	Float type auto drain	-	Without auto drain	●	●	●
			<b>C</b>	Float type auto drain (N.C.)	●	●	●
			<b>D</b>	Float type auto drain (N.O.)	—	●	●
	+						
	c	Pressure gauge	-	Without pressure gauge	●	●	●
			<b>E</b>	Square embedded type pressure gauge	●	●	●
			<b>G</b>	Round type pressure switch	●	●	●
		Digital pressure switch	<b>E1</b> <small>Note 5)</small>	NPN output / Wiring bottom entry	●	●	●
<b>E2</b> <small>Note 5)</small>			NPN output / Wiring top entry	●	●	●	
<b>E3</b> <small>Note 5)</small>			PNP output / Wiring bottom entry	●	●	●	
<b>E4</b> <small>Note 5)</small>	PNP output / Wiring top entry	●	●	●			
+							
⑤ Semi-standard	d	Set pressure	-	0.05 to 0.85 MPa set	●	●	●
			<b>1</b> <small>Note 6)</small>	0.02 to 0.2 MPa set	●	●	●
	+						
	e	Bowl	-	Polycarbonate bowl	●	●	●
			<b>2</b>	Metal bowl	●	●	●
			<b>6</b>	Nylon bowl	●	●	●
			<b>8</b>	Metal bowl with level gauge	—	●	●
			<b>C</b>	With bowl guard	●	—	—
			<b>6C</b>	Nylon bowl with bowl guard	●	—	—
	+						
f	Drain port <small>Note 7)</small>	-	With drain cock	●	●	●	
		<b>J</b> <small>Note 8)</small>	Drain guide 1/8	●	—	—	
			Drain guide 1/4	—	●	●	
		<b>W</b> <small>Note 9)</small>	Drain cock with barb fitting: For ø6 x ø4 nylon tube	—	●	●	

# Mist Separator Regulator *Series AMW20 to AMW40*

## Micro Mist Separator Regulator *Series AWD20 to AWD40*



**AWM20, AWD20    AWM40, AWD40**

		Symbol	Description	①			
				Body size			
				20	30	40	
<b>5</b>	<b>g</b>	-	Relieving type	●	●	●	
		<b>N</b>	Non-relieving type	●	●	●	
			+				
	<b>h</b>	-	Flow direction: Left to right	●	●	●	
		<b>R</b>	Flow direction: Right to left	●	●	●	
			+				
	<b>i</b>	Pressure unit	-	Name plate, caution plate for bowl, and pressure gauge in SI units: MPa	●	●	●
			<b>Z</b> <small>Note 10</small>	Name plate, caution plate for bowl, and pressure gauge in imperial units (PSI, °F)	○ <small>Note 12</small>	○ <small>Note 12</small>	○ <small>Note 12</small>
		<b>ZA</b> <small>Note 11</small>	Digital pressure switch: With unit switching function	△ <small>Note 13</small>	△ <small>Note 13</small>	△ <small>Note 13</small>	

Note 1) Drain guide is NPT1/8 (applicable to the AWM20, AWD20) and NPT1/4 (applicable to the AWM30 to AWM40, AWD30 to AWD40). The exhaust port for auto drain comes with a  $\phi 3/8"$  One-touch fitting (applicable to the AWM30 to AWM40, AWD30 to AWD40).

Note 2) Drain guide is G1/8 (applicable to the AWM20 and AWD20) and G1/4 (applicable to the AWM30 to AWH40, AWD30 to AWD40).

Note 3) Option B, G, H are not assembled and are supplied loose at the time of shipment.

Note 4) Assembly includes a bracket and set nuts

Note 5) When choosing with H (panel mount), the installation space for the lead wire will be limited. In this case, select "wiring down entry" for the lead wire entry.

Note 6) The only difference from the standard specifications is the adjusting spring for the regulator. It does not restrict the setting of 0.2 MPa or more. When the pressure gauge is attached, a 0.2 MPa pressure gauge will be fitted.

Note 7) Float type auto drain: The combination between C or D is not available with the drain port options.

Note 8) Without a valve function

Note 9) Metal bowl: The combination of 2 or 8 cannot be selected with W.

Note 10) For thread type: NPT. This product is for overseas use only according to the new Measurement Law. (The SI unit type is provided for use in Japan.) The digital pressure switch will be equipped with the unit switching function, setting to PSI initially.

Note 11) For options: E1, E2, E3, E4. This product is for overseas use only according to the new Measurement Law. (The SI unit is provided for use in Japan.)

Note 12) ○: For thread type: NPT only

Note 13) △: Combination available for options: E1, E2, E3, E4.

### Standard Specifications

Model	AWM20 AWD20	AWM30 AWD30	AWM40 AWD40
<b>Port size</b>	1/8, 1/4	1/4, 3/8	1/4, 3/8, 1/2
<b>Fluid</b>	Air		
<b>Proof pressure</b>	1.5 MPa		
<b>Maximum operating pressure</b>	1.0 MPa		
<b>Set pressure range</b>	0.05 to 0.85 MPa		
<b>Pressure gauge port size</b> <small>Note 1)</small>	1/8		1/4
<b>Ambient and fluid temperature</b> <small>Note 2)</small>	-5 to 60°C (with no freezing)		
<b>Nominal filtration rating</b>	<b>AWM20 to AWM40</b>		0.3 $\mu\text{m}$ (95% filtered particle size)
	<b>AWD20 to AWD40</b>		0.01 $\mu\text{m}$ (95% filtered particle size)
<b>Outlet side oil mist concentration</b>	<b>AWM20 to AWM40</b>		Maximum 1.0 $\text{mg}/\text{m}^3$ (ANR) ( $\approx 0.8$ ppm) <small>Note 3) Note 4)</small>
	<b>AWD20 to AWD40</b>		Max. 0.1 $\text{mg}/\text{m}^3$ (ANR) (Before saturated with 0.001 $\text{mg}/\text{m}^3$ (ANR) or less $\approx 0.008$ ppm) <small>Note 3) Note 4)</small>
<b>Rated flow (d/min (ANR))</b> <small>Note 5)</small>	<b>AWM20 to AWM40</b>	150	330
	<b>AWD20 to AWD40</b>	90	180
<b>Drain capacity (cm<sup>3</sup>)</b>	8	25	45
<b>Bowl material</b>	Polycarbonate		
<b>Bowl guard</b>	Semi-standard	Standard	
<b>Regulator construction</b>	Relieving type		
<b>Weight (kg)</b>	0.44	0.59	1.25

Note 1) Pressure gauge connection threads are not available for units with a square embedded type pressure gauge.

Note 2) -5 to 50°C for the products with the digital pressure switch.

Note 3) When the compressor oil mist discharge concentration is 30  $\text{mg}/\text{m}^3$  (ANR).

Note 4) Bowl O-ring and other O-rings are slightly lubricated.

Note 5) Conditions: Inlet pressure: 0.1 MPa, set pressure: 0.5 MPa; The rated flow varies depending on the inlet pressure. Keep the air flow within the rated flow to prevent an outflow of lubricant to the outlet side.

# Series AWM20 to AWM40

# Series AWD20 to AWD40

## Option / Part No.

Option		Model	AWM20 AWD20	AWM30 AWD30	AWM40 AWD40
<b>Bracket assembly</b> <sup>Note 1)</sup>			AW20P-270AS	AR30P-270AS	AR40P-270AS
<b>Set nut</b>			AR20P-260S	AR30P-260S	AR40P-260S
<b>Pressure gauge</b>	<b>Round type</b> <sup>Note 2)</sup>	<b>Standard</b>	G36-10-□01		G46-10-□02
		<b>0.02 to 0.2 MPa set</b>	G36-2-□01		G46-2-□02
	<b>Square embedded type</b> <sup>Note 3)</sup>	<b>Standard</b>	GC3-10AS [GC3P-010AS (Pressure gauge cover only)]		
		<b>0.02 to 0.2 MPa set</b>	GC3-2AS [GC3P-010AS (Pressure gauge cover only)]		
<b>Digital pressure switch</b> <sup>Note 4)</sup>	<b>NPN output / Wiring bottom entry</b>		ISE35-N-25-MLA [ISE35-N-25-M (Switch body only)]		
	<b>NPN output / Wiring top entry</b>		ISE35-R-25-MLA [ISE35-R-25-M (Switch body only)]		
	<b>PNP output / Wiring bottom entry</b>		ISE35-N-65-MLA [ISE35-N-65-M (Switch body only)]		
	<b>NPN output / Wiring top entry</b>		ISE35-R-65-MLA [ISE35-R-65-M (Switch body only)]		
<b>Float type auto drain</b> <sup>Note 5)</sup>	<b>N.O.</b>		—	AD38	AD48
	<b>N.C.</b>		AD37	AD37	AD47

Note 1) Assembly includes a bracket and set nuts

Note 2) □ in part numbers for a round pressure gauge indicates a type of connection thread. No indication is necessary for R; however, indicate N for NPT. Please contact SMC regarding the connection thread NPT and pressure gauge supply for PSI unit specifications.

Note 3) Includes O-ring and 2 mounting screws. [ ]: Pressure gauge cover only

Note 4) Lead wire with connector (2 m), adaptor, lock pin, O-ring (1 pc.), mounting screw (2 pcs.) are attached. [ ]: Switch body only. Also, regarding how to order the digital pressure switch, please refer to page 73.

Note 5) Minimum operating pressure: N.O. type-0.1 MPa; N.C. type-0.1 MPa (AD27) and 0.15 MPa (AD37/47). Please contact SMC for PSI unit and "F" specifications.

## ⚠ Specific Product Precautions

**Be sure to read this before handling. Refer to "Precautions for Handling Pneumatic Devices" (M-03-E3A) for Safety Instructions and F.R.L. Unit Precautions.**

### Selection

#### ⚠ Warning

- Residual pressure release (outlet pressure release) is not complete by releasing inlet pressure. Please contact SMC regarding residual pressure release.

### Air Supply

#### ⚠ Caution

- Install an air filter (the AF series) as a preliminary filter on the inlet side of the mist separator regulator to prevent premature clogging.
- Install an air filter (the AFM series) as a preliminary filter on the inlet side of the micro mist separator regulator to prevent premature clogging.

### Maintenance

#### ⚠ Warning

- Replace the element every 2 years or when the pressure drop becomes 0.1 MPa, whichever comes first, to prevent damage to the element.

### Mounting and Adjustment

#### ⚠ Caution

- Set the regulator while verifying the displayed values of the inlet and outlet pressure gauges. Turning the regulator knob excessively can cause damage to the internal parts.
- The pressure gauge included with regulators for 0.02 to 0.2 MPa setting is for up to 0.2 MPa use only (except for the AR10). Exceeding 0.2 MPa of pressure can damage the gauge.
- Do not use tools on the pressure regulator knob as this may cause damage. It must be operated manually.

### Mounting and Adjustment

#### ⚠ Warning

- Be sure to unlock the knob before adjusting the pressure and lock it after setting the pressure. Failure to follow this procedure can cause damage to the knob and the outlet pressure may fluctuate.
  - Pull the pressure regulator knob to unlock. (You can visually verify this with the "orange mark" that appears in the gap.)
  - Push the pressure regulator knob to lock. When the knob is not easily locked, turn it left and right a little and then push it (when the knob is locked, the "orange mark", i.e., the gap will disappear).
- A knob cover is available to prevent careless operation of the knob. Refer to "Features 1" for details.



# Mist Separator Regulator *Series AWM20 to AWM40*

## Micro Mist Separator Regulator *Series AWD20 to AWD40*

### Flow Characteristics (Representative values)

Condition: Inlet pressure 0.7 MPa

**AWM20** Rc 1/4

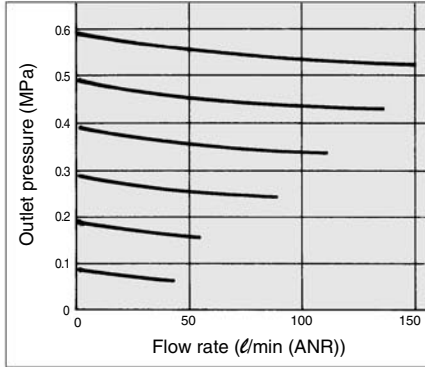

**AWM30** Rc 3/8

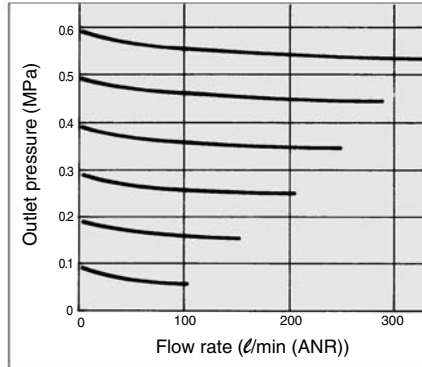

**AWM40** Rc 1/2

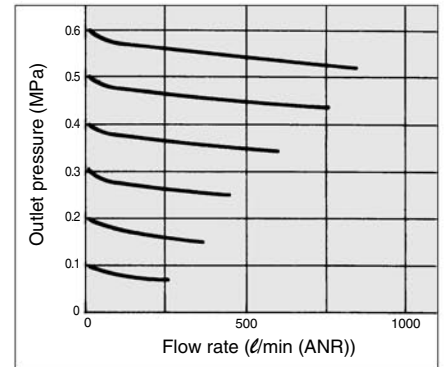

**AWD20** Rc 1/4

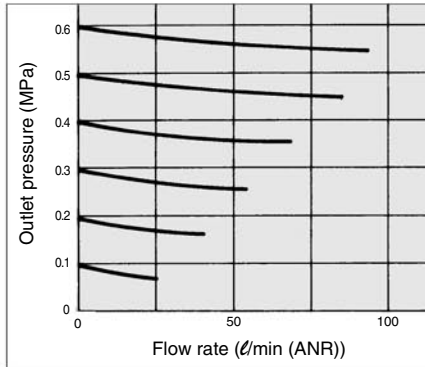

**AWD30** Rc 3/8

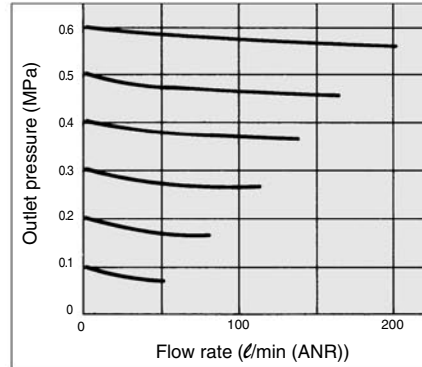

**AWD40** Rc 1/2

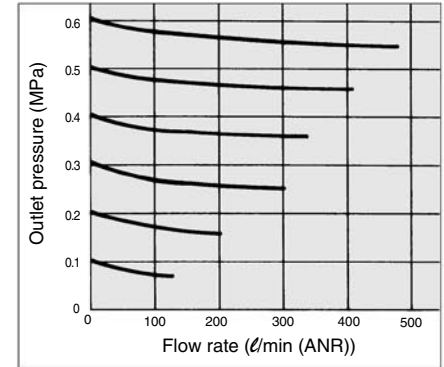

### Pressure Characteristics (Representative values)

Conditions: Inlet pressure 0.7 MPa, Outlet pressure 0.2 MPa, Flow rate 20 l/min (ANR)

**AWM20**

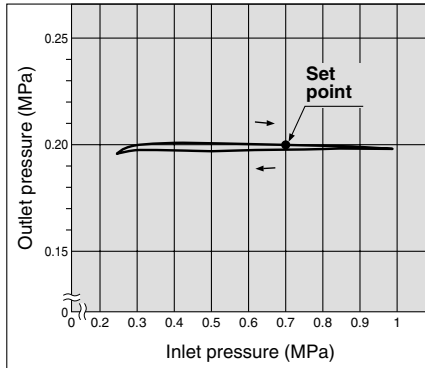

**AWM30**

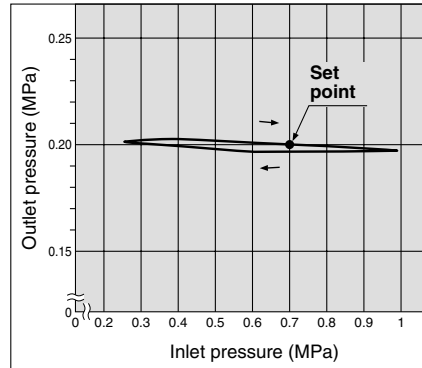

**AWM40**

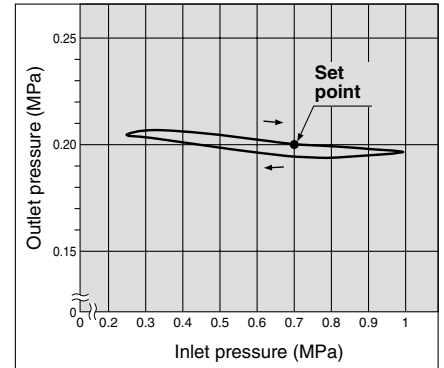

**AWD20**

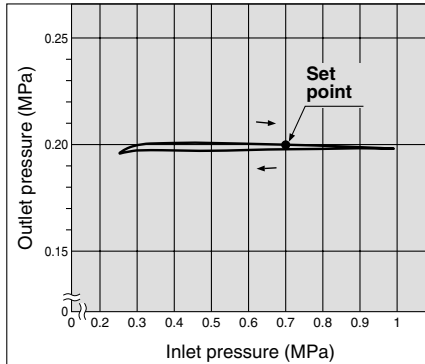

**AWD30**

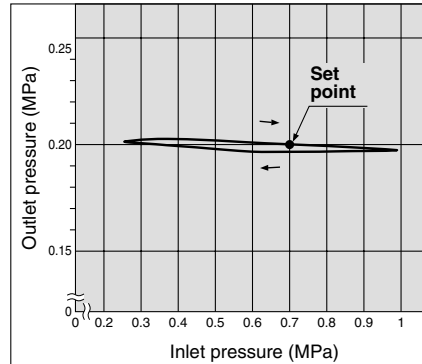

**AWD40**

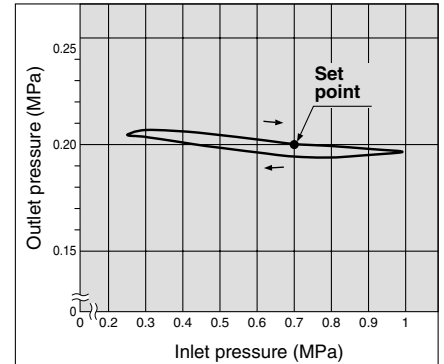

# Series AWM20 to AWM40

# Series AWD20 to AWD40

## Construction

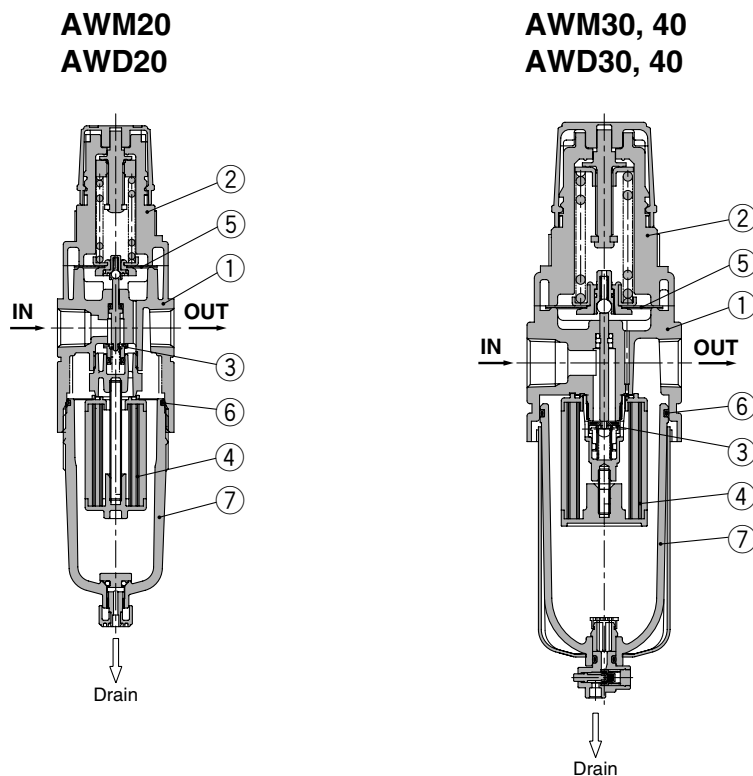

## Component Parts

No.	Description	Material	Model	Note
1	Body	Zinc die-cast	AWM20 AWD20	Platinum silver
		Aluminum die-cast	AWM30, AWM40 AWD30, AWD40	
2	Bonnet	Polyacetal	AWM20 to AWM40 AWD20 to AWD40	Black

## Replacement Parts

No.	Description	Material	Part no.		
			AWM20 AWD20	AWM30 AWD30	AWM40 AWD40
3	Valve assembly	Brass, HNBR	AWM20P-090AS	AWM30P-090AS	AWM40P-090AS
4	Element assembly	AWM20 to AWM40	AFM20P-060AS	AFM30P-060AS	AFM40P-060AS
		AWD20 to AWD40	AFD20P-060AS	AFD30P-060AS	AFD40P-060AS
5	Diaphragm assembly	Weatherable NBR	AR20P-150AS	AR30P-150AS	AR40P-150AS
6	Bowl O-ring	NBR	C2SFP-260S	C3SFP-260S	C4SFP-260S
7	Bowl assembly <sup>Note 1)</sup>	Polycarbonate	C2SF	C3SF <sup>Note 2)</sup>	C4SF <sup>Note 2)</sup>

Note 2) Includes O-ring. Please contact SMC regarding the bowl assembly supply for PSI and °F unit specifications.

Note 3) Bowl assembly for the AWM30, AWM40/AWD30, AWD40 comes with a bowl guard (steel band material).

# Mist Separator Regulator *Series AMW20 to AMW40*

## Micro Mist Separator Regulator *Series AWD20 to AWD40*

### Dimensions

**AWM20  
AWD20**

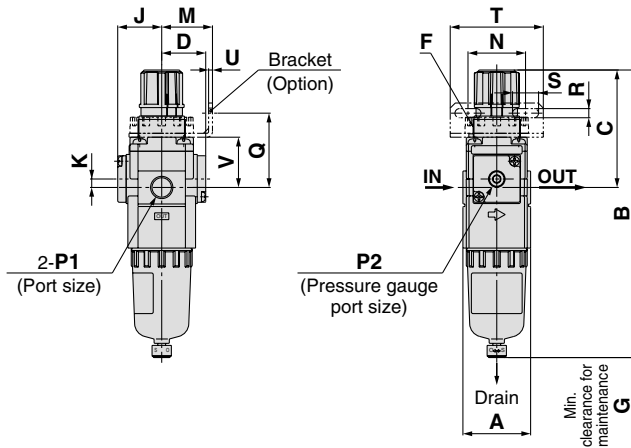

Panel fitting dimension

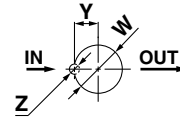

AWM20/AWD20: Max. 3.5

**AWM30, AWM40  
AWD30, AWD40**

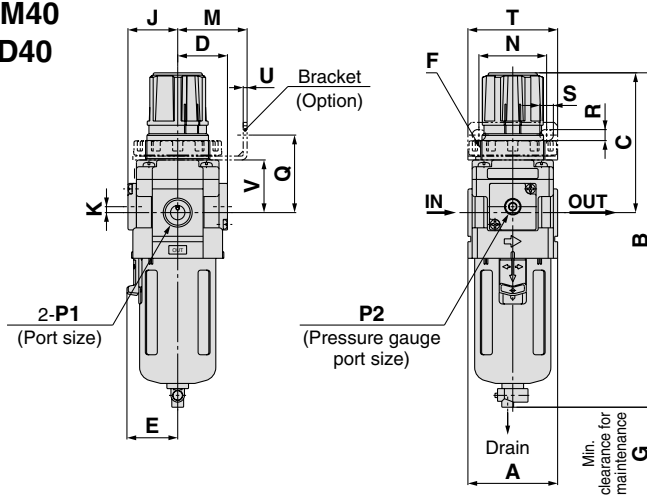

Panel fitting dimension

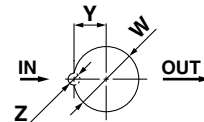

AWM30/AWD30: Max. 3.5  
AWM40/AWD40: Max. 5

Applicable model	AWM20, AWM40/AWD20 to AWD40		
Option	Square embedded type pressure gauge	Digital pressure switch	Round type pressure gauge
Dimensions			

Applicable model	AWM20, AWD20				AWM30, AWM40/AWD30, AWD40				
	Optional/Semi-standard specifications	With auto drain (N.C.)	Metal bowl	With drain guide	With auto drain (N.O./N.C.)	Metal bowl	Metal bowl with level gauge	With drain guide	Drain cock with barb fitting
Dimensions									

Model	Standard specifications											Optional specifications					
	P1	P2	A	B (Note)	C	D	E	F	G	J	K	Square type pressure gauge	Digital pressure gauge	Round type pressure gauge			
AWM20/AWD20	1/8, 1/4	1/8	40	160	73	26	—	M28 x 1	40	26	5	□28	27	□27.8	37.5	ø37.5	63
AWM30/AWD30	1/4, 3/8	1/8	53	201	86	29.5	30	M38 x 1.5	55	29.5	3.5	□28	30.5	□27.8	41	ø37.5	66
AWM40/AWD40	1/4, 3/8, 1/2	1/4	70	239	92	37.5	38	M42 x 1.5	80	37.5	1.5	□28	38.5	□27.8	49	ø42.5	76

Model	Optional specifications											Semi-standard specifications				
	Bracket mount					Panel mount						With auto drain	With barb fitting	With drain guide	Metal bowl	Metal bowl with level gauge
	M	N	Q	R	S	T	U	V	W	Y	Z	B	B	B	B	B
AWM20/AWD20	30	34	44	5.4	15.4	55	2.3	30	28.5	14	6	177	—	164	160	—
AWM30/AWD30	41	40	46	6.5	8	53	2.3	31	38.5	19	7	242	209	208	214	234
AWM40/AWD40	50	54	54	8.5	10.5	70	2.3	35.5	42.5	21	7	278	247	246	252	272

Note) The total length of B dimension is the length when the filter regulator handle is unlocked.

# Options

# Digital Pressure Switch

ISE35 — **N** — **25** — **M** **L** **A**

① ② ③ ④ ⑤

		Symbol	Description
①	Lead wire entry	N	Wiring bottom entry
		R	Wiring top entry

②	Output	+	25	NPN output
			65	PNP output
③	Display unit <small>Note 1)</small>	+	-	<small>Note 2)</small> With unit switching function
			M	Fixed SI unit
			P <small>Note 2)</small>	Pressure unit: PSI (initial value) with unit display switching function
④	Lead wire	+	-	Without lead wire
			L	Lead wire with connector
⑤	Lead wire entry	+	-	Without accessories (switch body only)
			A	With accessories (adaptor, O-ring (1 pc.), mounting screw (2 pcs.), lock pin)

Note 1) This product is for overseas use only according to the new Measurement Law.  
 Note 2) Unit name plate is attached.  
 Note 3) Instruction manual is attached.  
 Note 4) When ordering the body only, select the symbol from ① to ⑤ respectively.

## Applicable Series

F.R.L. unit	AC20, AC25, AC30, AC40, AC50, AC55, AC60 AC20A, AC30A, AC40A, AC50A, AC60A AC20B, AC25B, AC30B, AC40A, AC50A, AC55B, AC60B AC20C, AC25C, V30C, AC40C AC20D, AC30D, V40D
Regulator	AR20, AR25, AR30, AR40, AR50, AR60
Filter regulator	AW20, AW30, AW40, AW60
Mist separator regulator	AWM20, AWM30, AWM40
Micro mist separator regulator	AWD20, AWD30, AWD40

## Digital Pressure Switch Details

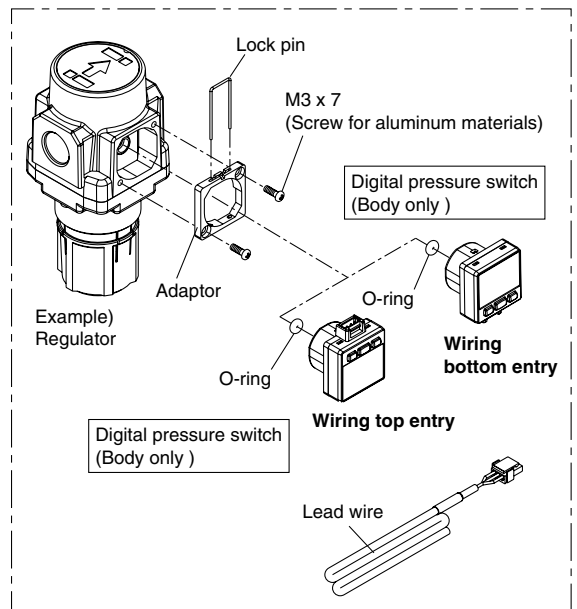

## Specifications

Rated pressure range	0 to 1 MPa	
Set pressure range	-0.1 to 1 MPa	
Withstand pressure	1.5 MPa	
Set pressure resolution	0.01 MPa	
Power supply voltage	12 to 24 VDC, Ripple (p-p) 10% or less (with power supply polarity protection)	
Current consumption	55 mA or less (at no load)	
Switch output	NPN or PNP open collector 1 output	
Max. load current	80 mA	
Max. applied voltage	30 V (with NPN output)	
Residual voltage	1 V or less (with load current of 80 mA)	
Response time	1 s	
Anti-chattering function	(Response time selections: 0.25, 0.5, 2, 3)	
Short circuit protection	With short circuit protection	
Repeatability	±1%F.S. or less	
Hysteresis	Hyseresis mode	Variable (can be set from 0)
	Window comparator mode	
Display	3-digit, 7-segment indicator, 2-colour display (Red/Green) can be interlocked with the switch output.	
Display accuracy	±2%F.S. ± 1 digit (at 25°C ± 3°C)	
Indication light	Illuminates when output is turned ON. (Green)	
Environmental resistance	Enclosure	IP40
Lead wire with connector		ø3.4 3-wire 25AWG 2 m

## Output

### NPN open collector

Max. 30 V, 80 mA  
 Residual output voltage 1 V or less

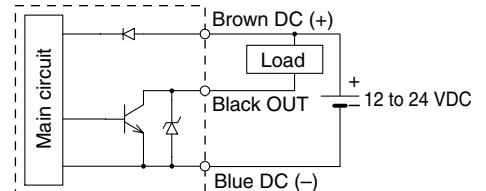

### PNP open collector

Max. 80 mA  
 Residual output voltage 1 V or less

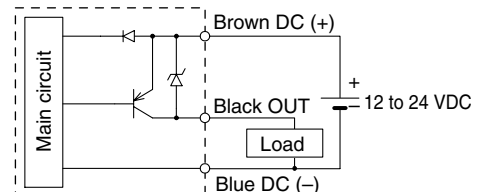





## Series AC

# Safety Instructions

These safety instructions are intended to prevent a hazardous situation and/or equipment damage. These instructions indicate the level of potential hazard by labels of "Caution", "Warning" or "Danger". To ensure safety, be sure to observe ISO 4414 <sup>Note 1)</sup>, JIS B 8370 <sup>Note 2)</sup> and other safety practices.

### ■ Explanation of the Labels

Labels	Explanation of the labels
 <b>Danger</b>	In extreme conditions, there is a possible result of serious injury or loss of life.
 <b>Warning</b>	Operator error could result in serious injury or loss of life.
 <b>Caution</b>	Operator error could result in injury <sup>Note 3)</sup> or equipment damage. <sup>Note 4)</sup>

Note 1) ISO 4414: Pneumatic fluid power – General rules relating to systems

Note 2) JIS B 8370: General Rules for Pneumatic Equipment

Note 3) Injury indicates light wounds, burns and electrical shocks that do not require hospitalisation or hospital visits for long-term medical treatment.

Note 4) Equipment damage refers to extensive damage to the equipment and surrounding devices.

### ■ Selection/Handling/Applications

#### 1. The compatibility of the pneumatic equipment is the responsibility of the person who designs the pneumatic system or decides its specifications.

Since the products specified here are used in various operating conditions, their compatibility for the specific pneumatic system must be based on specifications or post analysis and/or tests to meet the specific requirements. The expected performance and safety assurance are the responsibility of the person who has determined the compatibility of the system. This person should continuously review the suitability of all items specified, referring to the latest catalogue information with a view to giving due consideration to any possibility of equipment failure when configuring a system.

#### 2. Only trained personnel should operate pneumatic machinery and equipment.

Compressed air can be dangerous if handled incorrectly. Assembly, handling or repair of the systems using pneumatic equipment should be performed by trained and experienced operators. (Understanding JIS B 8370 General Rules for Pneumatic Equipment, and other safety rules are included.)

#### 3. Do not service the machinery/equipment or attempt to remove components until safety is confirmed.

1. Inspection and maintenance of the machinery/equipment should only be performed once measures to prevent falling or runaway of the driven objects have been confirmed.
2. If the equipment must be removed, confirm the safety process as mentioned above. Turn off the supply pressure for the equipment and exhaust all residual compressed air in the system, and release all the energy (liquid pressure, spring, condenser, gravity).
3. Before the machinery/equipment is restarted, take measures to prevent quick extension of a cylinder piston rod, etc.

#### 4. If the equipment will be used in the following conditions or environment, please contact SMC first and be sure to take all necessary safety precautions.

1. Conditions and environments beyond the given specifications, or if product is used outdoors.
2. Installation on equipment in conjunction with atomic energy, railway, air navigation, vehicles, medical equipment, food and beverages, recreation equipment, emergency stop circuits, clutch and brake circuits in press applications, or safety equipment.
3. An application which has the possibility of having negative effects on people, property, requiring special safety analysis.
4. If the products are used in an interlock circuit, prepare a double interlock style circuit with a mechanical protection function for the prevention of a breakdown. And, examine the devices periodically if they function normally or not.

### ■ Exemption from Liability

1. SMC, its officers and employees shall be exempted from liability for any loss or damage arising out of earthquakes or fire, action by a third person, accidents, customer error with or without intention, product misuse, and any other damages caused by abnormal operating conditions.

2. SMC, its officers and employees shall be exempted from liability for any direct or indirect loss or damage, including consequential loss or damage, loss of profits, or loss of chance, claims, demands, proceedings, costs, expenses, awards, judgments and any other liability whatsoever including legal costs and expenses, which may be suffered or incurred, whether in tort (including negligence), contract, breach of statutory duty, equity or otherwise.

3. SMC is exempted from liability for any damages caused by operations not contained in the catalogues and/or instruction manuals, and operations outside of the specification range.

4. SMC is exempted from liability for any loss or damage whatsoever caused by malfunctions of its products when combined with other devices or software.



## EUROPEAN SUBSIDIARIES:



### Austria

SMC Pneumatik GmbH (Austria).  
Girakstrasse 8, A-2100 Korneuburg  
Phone: +43 2262-62280, Fax: +43 2262-62285  
E-mail: office@smc.at  
http://www.smc.at



### France

SMC Pneumatique, S.A.  
1, Boulevard de Strasbourg, Parc Gustave Eiffel  
Bussy Saint Georges F-77607 Mame La Vallee Cedex 3  
Phone: +33 (0)1-6476 1000, Fax: +33 (0)1-6476 1010  
E-mail: contact@smc-france.fr  
http://www.smc-france.fr



### Netherlands

SMC Pneumatics BV  
De Ruyterkade 120, NL-1011 AB Amsterdam  
Phone: +31 (0)20-5318888, Fax: +31 (0)20-5318880  
E-mail: info@smcpneumatics.nl  
http://www.smcneumatics.nl



### Spain

SMC España, S.A.  
Zuazobidea 14, 01015 Vitoria  
Phone: +34 945-184 100, Fax: +34 945-184 124  
E-mail: post@smc.smces.es  
http://www.smces.es



### Belgium

SMC Pneumatics N.V./S.A.  
Nijverheidsstraat 20, B-2160 Wommelgem  
Phone: +32 (0)3-355-1464, Fax: +32 (0)3-355-1466  
E-mail: post@smcpneumatics.be  
http://www.smcneumatics.be



### Germany

SMC Pneumatik GmbH  
Boschring 13-15, D-63329 Egelsbach  
Phone: +49 (0)6103-4020, Fax: +49 (0)6103-402139  
E-mail: info@smc-pneumatik.de  
http://www.smc-pneumatik.de



### Norway

SMC Pneumatics Norway A/S  
Vollsveien 13 C, Granfos Næringspark N-1366 Lysaker  
Tel: +47 67 12 90 20, Fax: +47 67 12 90 21  
E-mail: post@smc-norge.no  
http://www.smc-norge.no



### Sweden

SMC Pneumatics Sweden AB  
Ekhagsvägen 29-31, S-141 71 Huddinge  
Phone: +46 (0)8-603 12 00, Fax: +46 (0)8-603 12 90  
E-mail: post@smcpneumatics.se  
http://www.smc.nu



### Bulgaria

SMC Industrial Automation Bulgaria EOOD  
16 Kliment Ohridski Blvd., fl.13 BG-1756 Sofia  
Phone: +359 2 9744492, Fax: +359 2 9744519  
E-mail: office@smc.bg  
http://www.smc.bg



### Greece

S. Parianopoulos S.A.  
7, Konstantinoupoleos Street, GR-11855 Athens  
Phone: +30 (0)1-3426076, Fax: +30 (0)1-3455578  
E-mail: parianos@hol.gr  
http://www.smceu.com



### Poland

SMC Industrial Automation Polska Sp.z.o.o.  
ul. Konstruktorska 11A, PL-02-673 Warszawa,  
Phone: +48 22 548 5085, Fax: +48 22 548 5087  
E-mail: office@smc.pl  
http://www.smc.pl



### Switzerland

SMC Pneumatik AG  
Dorfstrasse 7, CH-8484 Weisslingen  
Phone: +41 (0)52-396-3131, Fax: +41 (0)52-396-3191  
E-mail: info@smc.ch  
http://www.smc.ch



### Croatia

SMC Industrijska automatika d.o.o.  
Cromerec 12, 10000 ZAGREB  
Phone: +385 1 377 66 74, Fax: +385 1 377 66 74  
E-mail: office@smc.hr  
http://www.smceu.com



### Hungary

SMC Hungary Ipari Automatizálási Kft.  
Budafoki út 107-113, H-1117 Budapest  
Phone: +36 1 371 1343, Fax: +36 1 371 1344  
E-mail: office@smc-automation.hu  
http://www.smc-automation.hu



### Portugal

SMC Sucursal Portugal, S.A.  
Rua de Engº Ferreira Dias 452, 4100-246 Porto  
Phone: +351 22-610-89-22, Fax: +351 22-610-89-36  
E-mail: postpt@smc.smces.es  
http://www.smces.es



### Turkey

Entek Pnömatik San. ve Tic Ltd. Sti.  
Perpa Tic. Merkezi Kat: 11 No: 1625, TR-80270 Okmeydanı Istanbul  
Phone: +90 (0)212-221-1512, Fax: +90 (0)212-221-1519  
E-mail: smc-entek@entek.com.tr  
http://www.entek.com.tr



### Czech Republic

SMC Industrial Automation CZ s.r.o.  
Hudcova 78a, CZ-61200 Brno  
Phone: +420 5 414 24611, Fax: +420 5 412 18034  
E-mail: office@smc.cz  
http://www.smc.cz



### Ireland

SMC Pneumatics (Ireland) Ltd.  
2002 Citywest Business Campus, Naas Road, Saggart, Co. Dublin  
Phone: +353 (0)1-403 9000, Fax: +353 (0)1-464-0500  
E-mail: sales@smcpneumatics.ie  
http://www.smcneumatics.ie



### Romania

SMC Romania srl  
Str. Fruzzei 29, Sector 2, Bucharest  
Phone: +40 213205111, Fax: +40 213261489  
E-mail: smcromania@smcromania.ro  
http://www.smcromania.ro



### UK

SMC Pneumatics (UK) Ltd  
Vincent Avenue, Crownhill, Milton Keynes, MK8 0AN  
Phone: +44 (0)800 1382930 Fax: +44 (0)1908-555064  
E-mail: sales@smcpneumatics.co.uk  
http://www.smcneumatics.co.uk



### Denmark

SMC Pneumatik A/S  
Knudsminde 4B, DK-8300 Odder  
Phone: +45 70252900, Fax: +45 70252901  
E-mail: smc@smc-pneumatik.dk  
http://www.smcck.com



### Italy

SMC Italia S.p.A  
Via Garibaldi 62, I-20061 Carugate, (Milano)  
Phone: +39 (0)2-927111, Fax: +39 (0)2-9271365  
E-mail: mailbox@smcitalia.it  
http://www.smcitalia.it



### Russia

SMC Pneumatik LLC.  
4B Sverdlovskaja nab, St. Petersburg 195009  
Phone: +812 718 5445, Fax: +812 718 5449  
E-mail: info@smc-pneumatik.ru  
http://www.smc-pneumatik.ru



### Estonia

SMC Pneumatics Estonia OÜ  
Laki 12-101, 106 21 Tallinn  
Phone: +372 (0)6 593540, Fax: +372 (0)6 593541  
E-mail: smc@smcpneumatics.ee  
http://www.smcneumatics.ee



### Latvia

SMC Pneumatics Latvia SIA  
Smerla 1-705, Riga LV-1006, Latvia  
Phone: +371 781-77-00, Fax: +371 781-77-01  
E-mail: info@smclv.lv  
http://www.smclv.lv



### Slovakia

SMC Priemyselná Automatizácia, s.r.o.  
Námestie Martina Benku 10, SK-81107 Bratislava  
Phone: +421 2 444 56725, Fax: +421 2 444 56028  
E-mail: office@smc.sk  
http://www.smc.sk



### Finland

SMC Pneumatics Finland OY  
PL72, Tiistintuntintie 4, SF-02031 ESPOO  
Phone: +358 207 513513, Fax: +358 207 513595  
E-mail: smcfin@smc.fi  
http://www.smc.fi



### Lithuania

SMC Pneumatics Lietuva, UAB  
Savanoriu pr. 180, LT-01354 Vilnius, Lithuania  
Phone: +370 5 264 81 26, Fax: +370 5 264 81 26



### Slovenia

SMC Industrijska Avtomatika d.o.o.  
Grajski trg 15, SLO-8360 Zuzemberk  
Phone: +386 738 85240 Fax: +386 738 85249  
E-mail: office@smc-ind-avtom.si  
http://www.smc-ind-avtom.si



## OTHER SUBSIDIARIES WORLDWIDE:

ARGENTINA, AUSTRALIA, BOLIVIA, BRASIL, CANADA, CHILE,  
CHINA, HONG KONG, INDIA, INDONESIA, MALAYSIA, MEXICO,  
NEW ZEALAND, PHILIPPINES, SINGAPORE, SOUTH KOREA,  
TAIWAN, THAILAND, USA, VENEZUELA

<http://www.smceu.com>  
<http://www.smcworld.com>