

Manual Switches

Advanced Manual Line

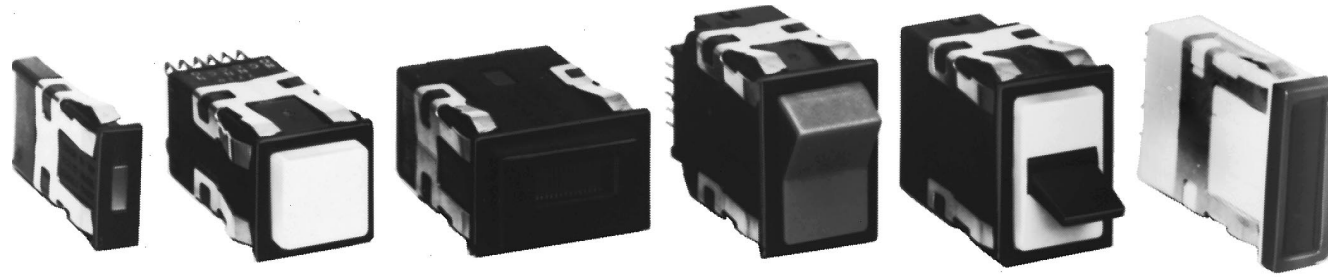

IN FRONT OF THE PANEL

Coordinated, attractive appearance. AML features innovations designed by industrial designers to achieve the best balance of human factors and aesthetic appearance. Operator height, bezel size, and the compatibility of square and rectangular shapes blend with other components to harmonize your panel. There's no visual clutter to distract from man/machine communication.

This comprehensive line of lighted and unlighted manual controls features:

- Pushbuttons for high and intermediate frequency functions;
- Rocker and paddle switches, with 2 or 3 positions, for less frequent control functions;
- Plus lighted indicators and annunciators which complement AML's universal appeal.

Various controls can be matched with their functions to accommodate the most natural and efficient habit pattern reflex. Keylock operated switches can be used to assure "authorized personnel only" access.

Display flexibility. AML offers a choice of five legend sizes, four button heights, full or split section display, and illumination by incandescent lamps, LED's or neons. Colors are bright and uniform, providing a strong definition and good visibility. (Non-illuminated devices have the same attractive colors.)

Color display options include:

- Transmitted color — color can be distinguished whether lamp is On or Off.
- Dead front — display appears black, until illumination causes legend and color to appear.
- Projected color — white display is diffused with color when illuminated.

BEHIND THE PANEL

AML's simple, cost effective design provides many behind-panel benefits for the designer and installer/user.

Simple to install. They snap in from the panel front individually or in vertical or horizontal strips; or in subpanel mounted strips and matrices that can be pre-assembled and pre-wired to assure accurate alignment and efficient panel building.

Electrical flexibility. Solid state switches with Hall effect integrated circuits interface directly with microprocessors and other logic level devices. These IC's were first applied in MICRO SWITCH solid state keyboards. Today, many MICRO SWITCH products incorporate the Hall effect technology to meet a wide range of position sensing and manual control needs.

Electronic control switches with gold or silver contacts, and 1, 2, or 4 poles, will handle up to 3 amps. Including an encoded version which generates different binary coded outputs merely by changing cam-keyed buttons.

Power duty switches meet line disconnect application needs with 10-amp push-buttons and 15-amp paddle and rocker switches.

Easy to wire. All AML devices present single level termination. This means faster, easier, neater, and more economical wiring. And there is a choice of solder, quick-connect, push-on, and printed circuit termination.

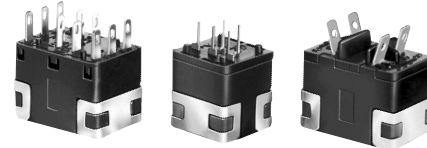

MATING RECEPTACLES

The .110 x .020 quick-connect/solder terminal (types 2 and 8) is designed for use with receptacles that comply with the UL standard for insertion and withdrawal forces. Maximum insertion force is 12 lbs. max., withdrawal force is 14 lbs. These receptacles are supplied by: AMP Inc., Berg, Augat, Hollingsworth, MALCO, Zierick, and others. Refer to Thomas Register or the Yellow Pages for the location of your local supplier.

Manuals

Manual Switches

Advanced Manual Line

FEATURES

- Complete selection of pushbutton, rocker and paddle (toggle type) switches accommodates different functions and promotes operator efficiency.
- Solid state, electronic, and power duty control.
- Full or split screen incandescent display switches and indicators provide vivid transmitted color, projected color (for neutral display when unlit), and dead front (hidden color).
- Wide-angle visibility LED and line voltage neon display switches and indicators.
- Annunciators back-lighted by LED's enable high density message display.
- Keylock switches available for controlled access applications.
- All AML terminations at the same shallow depth (1.7 in. /43,1 mm) for convenient wiring or PC board termination.
- Snap-in surface mount or sub-panel (hidden bezel) mount with mounting hardware.
- Pad printed legends with a clear polyurethane overcoat available in a choice of five standard sizes.
- Metric design for worldwide acceptance.
- UL recognized, CSA certification.
- Selected listings are certified by VDE and CE. (For compliance status, contact the 800 number.)

MICRO SWITCH AML Advanced Manual Line combines functional flexibility with electrical versatility to provide a broad range of options to choose from.

EASY TO RELAMP

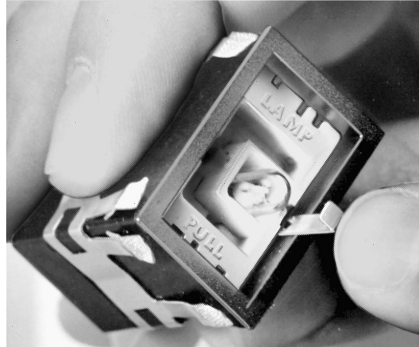

Relamping of T-1-3/4 incandescent AML91 lamps is accomplished from the front of the panel without tools. (AML92 T-1-3/4 LEDs can be added in the same manner.)

FULL GUARD BEZEL OPTION



As an alternative to standard height bezels (.06 in./1,5 mm), pushbutton switches can be furnished with full guard bezels extending .19 in./5.0 mm from the mounting surface. In the free position, standard buttons are flush with full guard bezels.

The raised bezel guards against accidental operation by someone leaning against or dropping something on a control console.

High Intensity LEDs For Full-face AML Lighted Display AML92 Series



- Full-face illumination for high visibility lighted colors.
- Advanced illumination technology combines high-intensity LED in standard T-1-3/4 wedge base lamp package.
- Easy plug-in installation in AML lighted switches and indicators.
- Low operating temperature permits high density, continuous operation with minimal heat build-up.

AML92 Series LEDs have a quad chip assembled in a T-1-3/4 wedge base lamp package. They provide full-face illumination when used with lighted pushbutton, rocker and paddle switches, or indicators equipped with incandescent lamp sockets. For ordering information, refer to page 58.

AML CHARACTERISTICS

	AML 10 Series	AML 20 Series	AML 30 Series	AML 40 Series
Electrical/Mechanical Life* Pushbuttons–Momentary	1,000,000	25,000 (silver)/ 100,000 (gold)	25,000	N/A ---
Pushbuttons–Alternate	25,000	25,000	25,000	---
Rockers	25,000	25,000	25,000	---
Paddles	25,000	25,000	25,000	---
Agency Ratings (May not apply to every series division)				
UL	File E53576	File E12252	File E12252	File E58932
CSA	File LR4442	File LR4442	File LR4442	File LR4442
VDE	None	File 0630/10.78+ Rating 1710	File 0630/10.78+ + Rating 1710	None
CE		No. 4275.5788	No. 4275.5788	

*95% Survival
 + Exception: Four-Pole AML's are not included in VDE Approval
 ++ Exception: Only the 2-pole AML33 and AML34 are certified by VDE

AML ELECTRICAL DATA

● AML10 Series

Electrical Characteristics						Absolute Maximum Rating ④			
Integrated Circuit Function	Supply Current (Max.)	Output Voltage (Operated)	Output Leakage Current max. (Released)	Switching Time Max.		Supply Voltage (V _s)	Voltage Externally Applied to Output	Loads to Output	Storage Temperature
				Rise 10% to 90%	Fall 90% to 10%				
5 VDC Sinking ①	3.5 mA (Released) 6.5mA (Operated — no load)	+ .4 Volt (Sinking 8 mA)	2.0 μA	1.0 μsec (Sinking 8 mA)	1.0 μsec (Sinking 8 mA)	-.5 to +7.0 VDC 0° to +65°C (+32° to +149°F)	-.5 Volt min. +15 Volts max. (Off condition)	20 mA (Sinking)	-40°C to +65°C (-40° to +149°F)
6-16 VDC Sinking ②	6.5 mA @ 6 VDC. 10.0 mA @ 16 VDC (Plus load current) ③	+ .4 Volt (Sinking 20mA max.)	20 μA	1.5 μsec (Sinking 20 mA)	0.5 μsec (Sinking 20 mA)	-1.2 to +20 VDC	+20 VDC max. in Off condition only -0.5 VDC min. in Off or On condition.	40 mA	-40°C to +65°C (-40° to +149°F)
4.5-24 VDC Sinking	5 V 7.0 mA (Released) 24 V 9.0 mA (Released) 14.0 mA (Operated-no load)	+ .4 Volt (Sinking 10 mA)	10 μA	1.5 μ sec (Sinking 10 mA)	0.5 μ sec (Sinking 10 mA)	-30 to +30 VDC	-0.5 Volt min. +24 Volts max. (Off condition)	20 mA (Sinking)	-40-C to +65°C (-40° to +149°F)

① Over temperature range of 0° to +55°C (+32° to +131°F) and supply voltage of 4.5 to 5.5 VDC.
 ② Over temperature range of 0° to +55°C (+32° to +131°F) and supply voltage of 16 VDC.
 ③ At 24°C. (+75°F)
 ④ As with all solid state components, performance can be expected to deteriorate as rating limits are approached; however, they will not be damaged unless the limits are exceeded.

● AML20 Series

Contacts	Voltage	Current	Load Type
Silver or Gold-plated Silver	250 VAC 125 VAC 24 VDC	2 Amps 3 Amps 2 Amps	75% Power Factor 75% Power Factor Resistive
Gold	125 VAC/DC	100 mA	Resistive

● AML30 Series

Voltage	Current		Load Type
	Pushbuttons	Rockers or Paddles	
125 VAC	10 amps	15 amps	60% power factor
250 VAC	10 amps	15 amps	60% power factor

Manuals

Manual Switches

Electronic Control Keylock

NON-LIGHTED

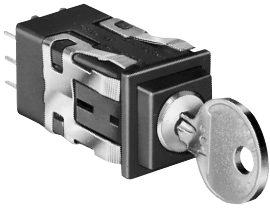

FEATURES

- Enable control of access to computer peripherals, keyboards, point-of-sale terminals, and security systems which are locked when unattended; and other locations where tampering must be discouraged.
- 2 or 3 positions, maintained (90° throw) and momentary action (60° throw).
- 5-bit key combinations

Electrical Data	page 19
Accessories	pages 56, 57
Mounting Dimensions	pages 59, 62

- UL recognized, CSA certified.
- Static discharge protection (up to 20 kV when grounded).

AML27 ORDER GUIDE

AML27 A	B	K	2	AA	21	BA
Housing Type	Bezel Color	Button Color	Terminal Type	Circuitry Codes (Each pole has double-throw)	Operation Action (Key out in center position, except where noted)	
AML27 A	B	K	2	Silver Contacts: AA 1 pole AC 2 pole	CCW	Center
Square housing	Black	Black	.110 × .020 (Solder or Quick-Connect)	Gold Contacts: BA 1 pole BC 2 pole	Center	CW
Non-Lighted			3		None	21
			.025 × .025 (Printed Circuit or Push-On)		Maint.	Maint.
					None	22*
					Maint.	Maint.
					None	23
					Maint.	Mom.
					Maint.	24
					Mom.	Maint.
					Maint.	25
					Mom.	Maint.
					Maint.	26**
					Mom.	Maint.
					Maint.	27***
					Mom.	Maint.
					Maint.	28***
					Maint.	Maint.
					Maint.	29†
					Maint.	Maint.
					Maint.	30†
					Maint.	Mom.
					Maint.	31††
					Maint.	Mom.

Key Combinations	
(Two Keys Furnished)	
BA	BL
BB	BM
BC	BN
BD	BP
BE	BQ
BF	BR
BG	BS
BH	BT
BJ	BV
BK	BW

REPLACEMENT KEYS

One key per listing.

Key Combination	Key Code	Catalog Listing
BA	110	30PA101-AML
BB	109	30PA102-AML
BC	108	30PA103-AML
BD	107	30PA104-AML
BE	106	30PA105-AML
BF	105	30PA106-AML
BG	104	30PA107-AML
BH	103	30PA108-AML
BJ	102	30PA109-AML
BK	101	30PA110-AML
BL	111	30PA111-AML
BM	112	30PA112-AML
BN	113	30PA113-AML
BP	114	30PA114-AML
BQ	115	30PA115-AML
BR	116	30PA116-AML
BS	117	30PA117-AML
BT	118	30PA118-AML
BV	119	30PA119-AML
BW	120	30PA120-AML

Note: These keys fit the 5-bit keylocks in the Order Guide.

Specify different Key Combinations to acquire different keys, i.e.; AML27ABK2AA21BB and AML27ABK2AA21BK have different keys. AML27ABK2AA21BB and AML27ABK3BC25BB have identical interchangeable keys.
Example: **AML27ABK2AC28BB**
Square housing; black bezel and button; .110 × .020 terminals; 2-pole double-throw; silver contacts; 3-position maintained and key code "BB".

CIRCUITRY

2-Position Switches:

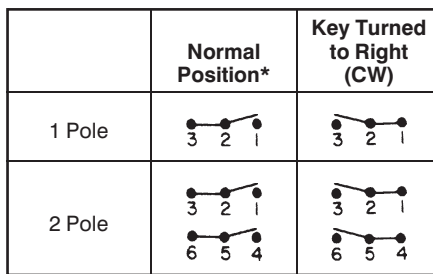

3-Position Switches (Available in 2-pole only.)

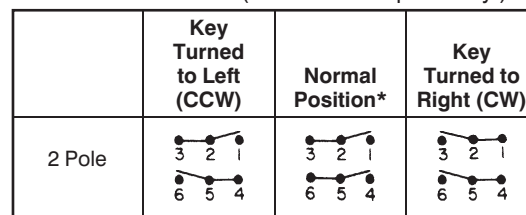

* Circuit remains the same with key in or out.

† Key out in center and CCW positions.
†† Key out in CCW only.

28 and 29 operating actions should be used with Key Combinations BA, BB, BG or BK.

Mounting Dimensions (For Reference Only)

AML11/12 and 21/22 SWITCHES AML41C/D and AML42C INDICATORS

Note: Top of full guard bezel housing
.19/5,0 from panel.

PUSHBUTTONS

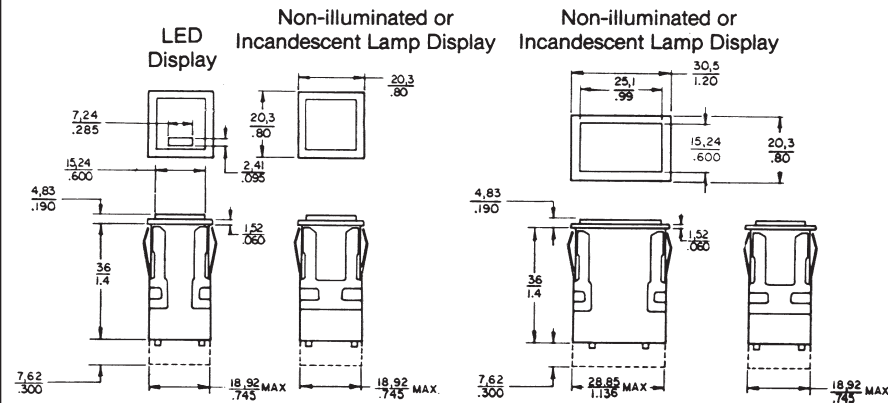

For terminal locations, see page 61.

AML27 SWITCHES

KEYLOCK

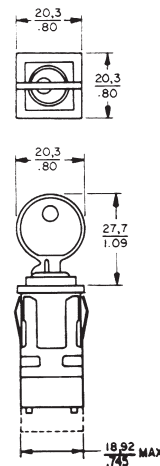

For terminal locations, see page 62.

AML14/16 and AML24/26 SWITCHES

ROCKERS

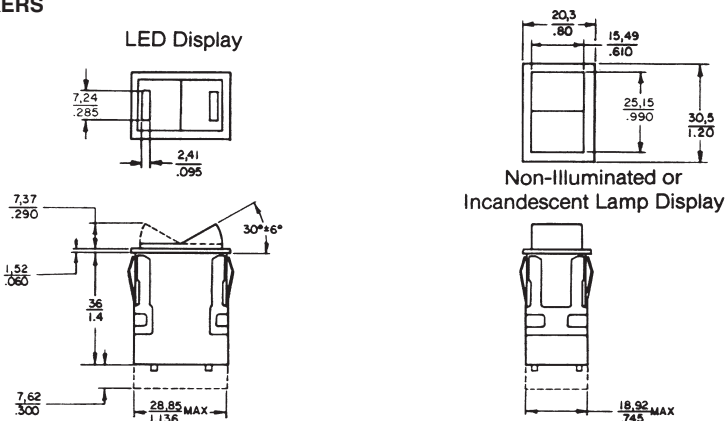

For terminal locations, see page 61, 62.

AML13/15 and 23/25 SWITCHES

PADDLES

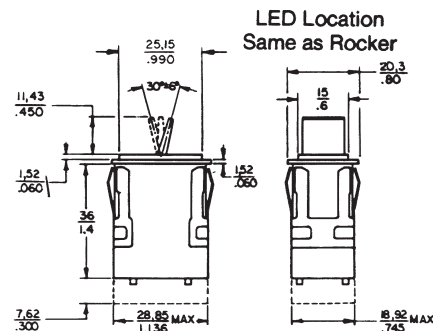

For terminal locations, see page 61, 62.

AML41 INDICATOR

LENS STYLE

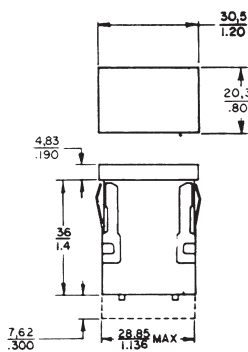

For terminal locations, see page 62.

AML42 INDICATOR

MINIATURE

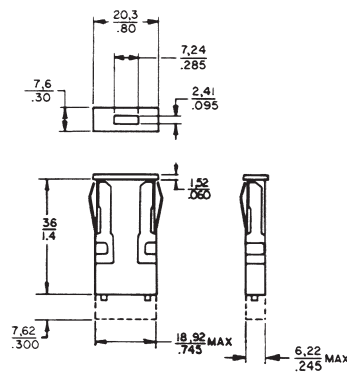

NOTE
1 Dimensions are mm or mm/IN
IN

TERMINAL TYPES

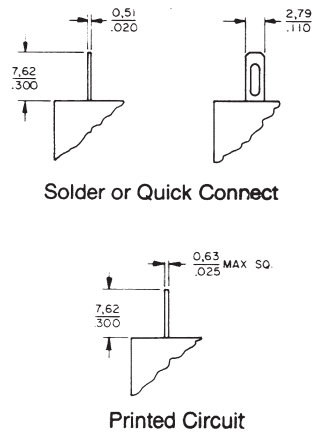

Solder Hole will accept two #22 AWG
Stranded Conductor (per NEMA publication
DC-2 1976)

Manuals

Manual Switches

Mounting Dimensions (For Reference Only)

AML Series

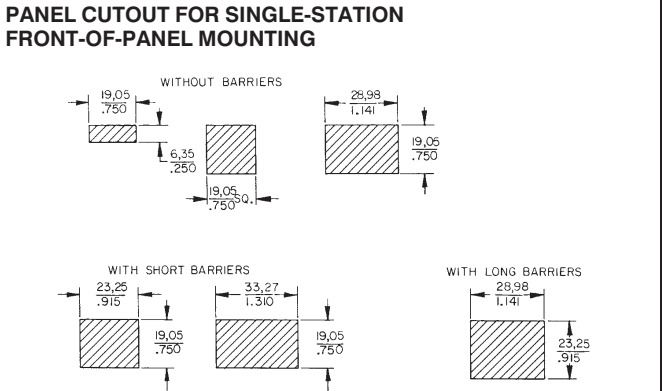
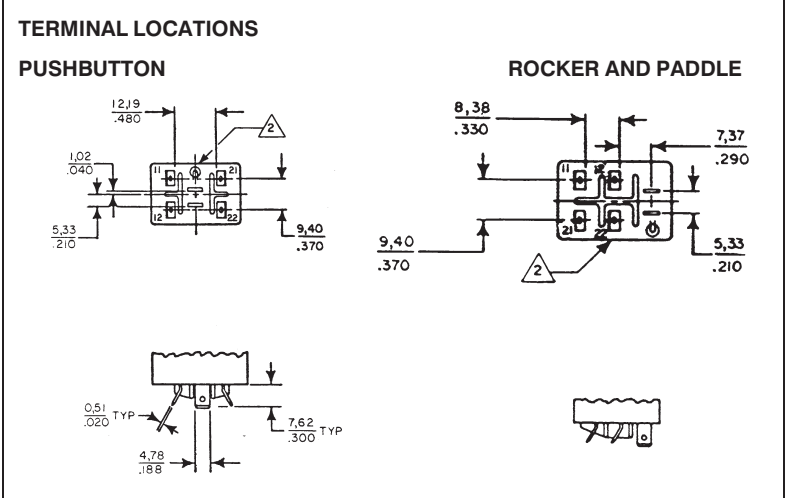
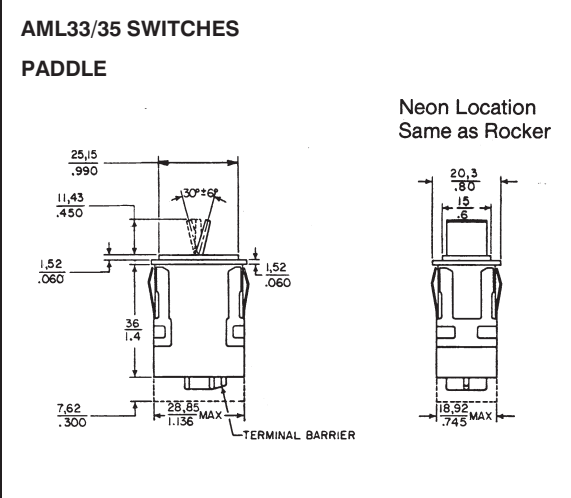
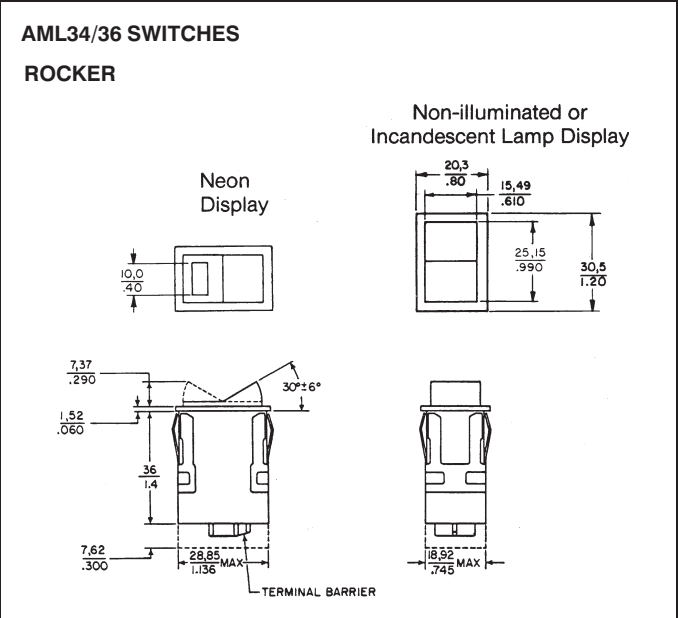
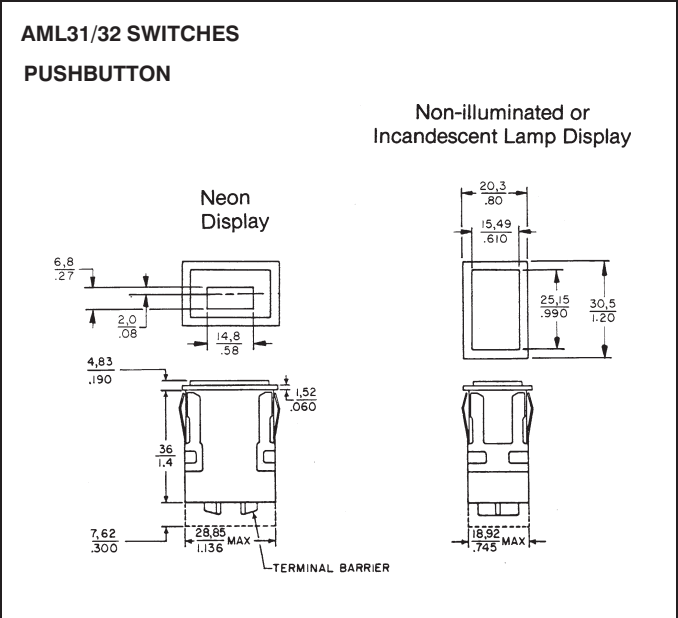

Recommended panel thickness: .060-.187/1.52-4.75

NOTES
 1 Dimensions are mm or mm/IN
 IN
 Manufacturers logo on this side of housing
 Solder Hole Will Accept One #14 AWG Stranded Conductor
 (Per NEMA Publication DC-2 1976)

PANEL PUNCH FOR AML SERIES
 A panel punch is manufactured by Greenlee-Texton Tool Co.,
 Rockford, IL (815-926-3011).

Manual Switches

Mounting Dimensions (For Reference Only)

TERMINAL LOCATIONS FOR AML10 SWITCHES

PUSHBUTTONS

Solder and Quick-Connect

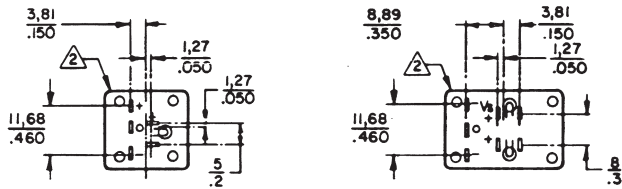

Printed Circuit

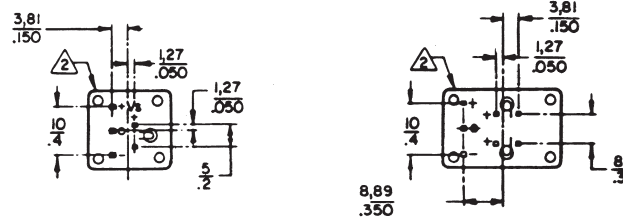

Illuminated devices shown (non-illuminated devices do not have lamp terminals).

ROCKERS AND PADDLES

Solder and Quick-Connect

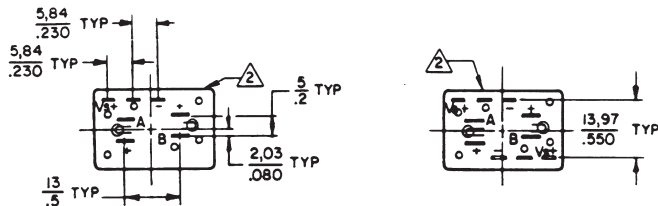

Printed Circuit

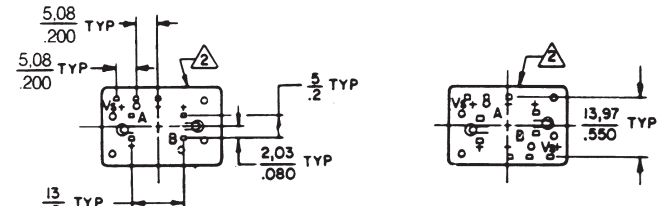

One Integrated Circuit

Two Integrated Circuits

One Integrated Circuit

Two Integrated Circuits

Illuminated devices shown (non-illuminated devices do not have lamp terminals)

TERMINAL LOCATIONS FOR AML41 INDICATORS

Solder and Quick-Connect

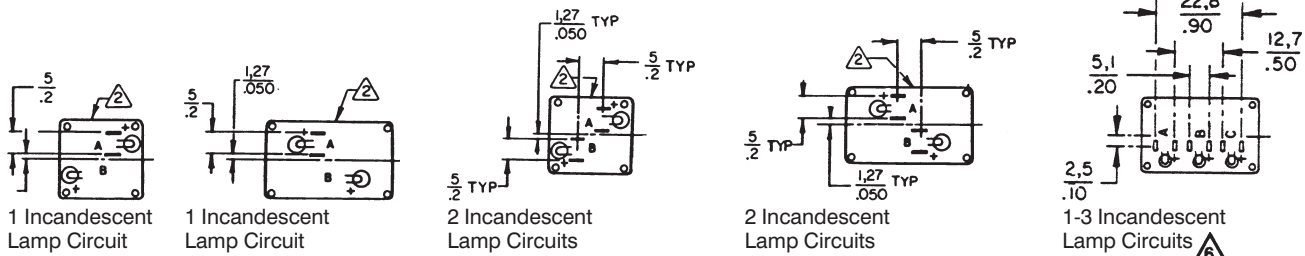

Printed Circuit

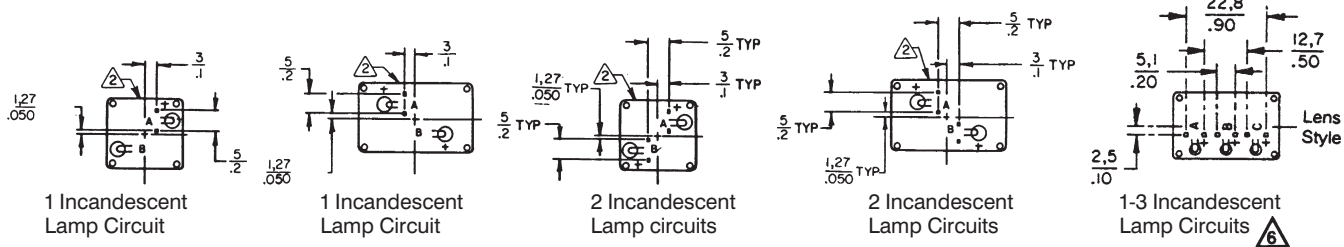

Manuals

TERMINAL LOCATIONS FOR AML42 INDICATORS

Solder and Quick-Connect

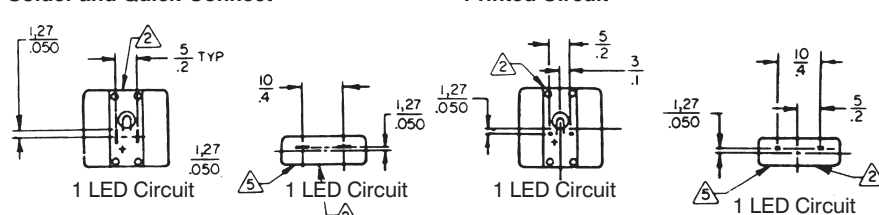

Printed Circuit

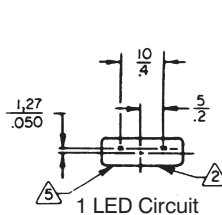

NOTE
 1 Dimensions are **MM** or **MM/IN**
 IN
 2 Manufacturer's logo on this side of housing
 4 - Lamp terminals are not provided for non-illuminated devices
 5 positive terminal ident. (+) marked this side of housing
 6 1 - lamp termination identified by "B".
 2 - lamp termination identified by "A" and "C".

Manual Switches

Mounting Dimensions (For Reference Only)

AML Series

TERMINAL LOCATIONS FOR AML20 SWITCHES

