

## Level sensing relay MK 9151 varimeter

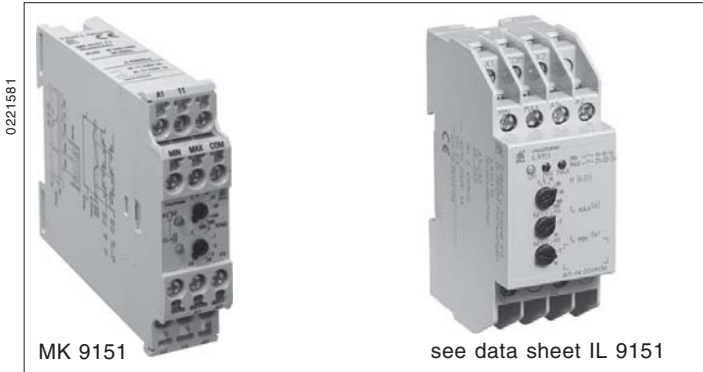

0221581

MK 9151

see data sheet IL 9151

- According to IEC/EN 60 255, DIN VDE 0435-303
- 3 probe connections for 2-point and 1-point level control
- Also for use as moisture detector
- High interference resistance of the measuring circuit, which is isolated from the mains
- Max. wire length to the probes: 1500 m
- Large setting range: 2 ... 450 kΩ  
this permits differentiation between fluid and foam
- Adjustable response and release time delay: 0,2 ... 20 s
- Programmable for open circuit operation (without bridge) or closed circuit operation (bridge X1-X2 or X1-COM)
- For auxiliary voltages of 24 ... 415 V AC or 24 V DC
- Green LED for operation
- Yellow LED for contact position
- 1 or 2 changeover contacts
- Also available with sealable transparent cover
- Available with safe separation according to IEC/EN 61 140, IEC/EN 60 947-1
- Width 22,5 mm

### Function diagrams

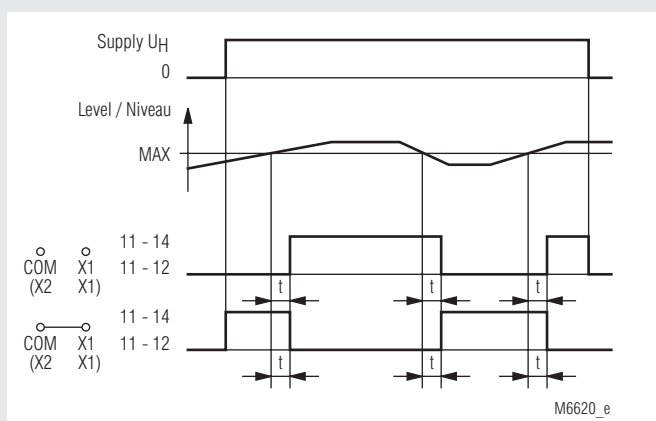

1-point level control

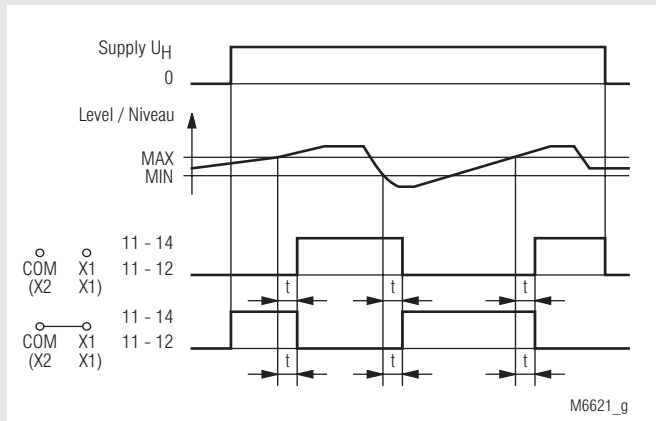

2-point level control

### Approvals and marking



\* see variants

### Application

- Level monitoring and control for conductive liquids and powders, e.g. maximum and minimum filling levels, overfilling and protection against dry running
- Monitoring and control of the mixing ratio of conductive liquids
- General resistance monitoring tasks, e.g. limit temperature detection with PTC

### Indicators

green LED: on, when supply connected  
yellow LED: on, when output relay active

### Notes

All commercially available probes are suitable.

The reference probe for level measurement is generally located at the lowest point of the container and must always be connected to the "COM" terminal. The container itself can be used as a reference probe if it consists of conductive material.

1-point level control (see Figure) is especially suitable for protection against overfilling and dry running on containers with a free inlet/outlet. In this configuration, all that is required besides the reference probe "COM" is the "MAX", which must be located at the desired limit level. The output relay switches over after the set delay time if the fluid level exceeds or falls below the limit level, which permits fluid to be pumped out or added.

### Circuit diagrams

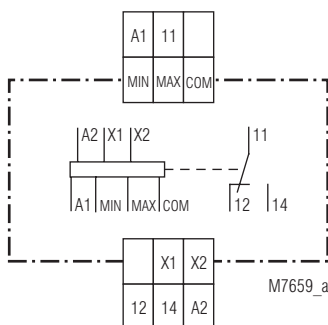

MK 9151.11

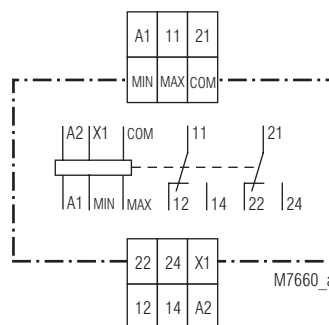

MK 9151.12

## Technical data

**Input**

**Setting range of the fluid resistance:** 2 ... 450 kΩ  
(other ranges on request)

**Setting:** on logarithmically divided absolute scale

**Switching point hysteresis:** approx. 3 % (at 450 kΩ) ... 6 % (at 2 kΩ) of the set value

**Voltage and temperature influence:** < 2 % of the set value

**Max. cable length to the probes:**

Set value	Cable length (at 100 nF/km)
450 kΩ	50 m
100 kΩ	200 m
35 kΩ	500 m
10 kΩ	1500 m
5 kΩ	3000 m

**Max. sensing voltage:** approx. AC 10 V

**Max. sensing current:** approx. AC 1,5 mA (internally generated)

**Response and release times:** 0,2 ... 20 s  
Setting on logarithmically-divided absolute scale

## Auxiliary circuit

**Auxiliary voltage  $U_H$ :** AC 24, 42 ... 48, 110 ... 127, 220 ... 240, 380 ... 415 V  
DC 24 V

**Voltage range of  $U_H$ :** AC: 0,8 ... 1,1  $U_N$   
DC: 0,85 ... 1,25  $U_N$

**Nominal power consumption:** AC: approx. 2 VA  
DC: approx. 1 W

**Frequency range:** 45 ... 400 Hz

## Output

**Contacts**

MK 9151.11: 1 changeover contact

MK 9151.12: 2 changeover contacts

**Thermal current  $I_m$ :** 5 A

**Switching capacity to AC 15**

NO contact: 3 A / AC 230 V IEC/EN 60 947-5-1

NC contact: 1 A / AC 230 V IEC/EN 60 947-5-1

**Electrical life to AC 15 at 1 A, AC 230 V:** 5 x 10<sup>5</sup> switching cycles IEC/EN 60 947-5-1

**Permissible operating:** 6 000 switching cycles / h

**Short-circuit strength max. fuse rating:** 4 A gL IEC/EN 60 947-5-1

**Mechanical life:** 30 x 10<sup>6</sup> switching cycles

## General data

**Operating mode:** Continuous operation

**Temperature range:** - 20 ... + 60°C

**Clearance and creepage distances**

overvoltage category / contamination level IEC 60 664-1

input/auxiliary circuit: 6 kV / 2 (1 kV for DC 24 V-devices)

input/output circuit: 6 kV / 2 (4 kV for MK 9151.12)

auxiliary/output circuit: 4 kV / 2

**EMC**

Electrostatic discharge: 8 kV (air) IEC/EN 61 000-4-2

HF irradiation: 10 V / m IEC/EN 61 000-4-3

Fast transients: 2 kV IEC/EN 61 000-4-4

Surge voltages: 1 kV IEC/EN 61 000-4-5

Interference suppression: Limit value class B EN 55 011

**Degree of protection:** Housing: IP 40 IEC/EN 60 529  
Terminals: IP 20 IEC/EN 60 529

**Housing:** Thermoplastic with V0 behavior according to UL subject 94

**Vibration resistance:** Amplitude 0,35 mm, frequency 10 ... 55 Hz, IEC/EN 60 068-2-6

**Climate resistance:** 20 / 060 / 04 IEC/EN 60 068-1

**Terminal designation:** EN 50 005

## Technische Daten

**Wire connection:** 2 x 1,5 mm<sup>2</sup> solid or 2 x 1,0 mm<sup>2</sup> stranded wire with sleeve DIN 46 228-1/-2/-3/-4

**Wire fixing:** Flat terminals with self-lifting clamping piece IEC/EN 60 999-1

**Mounting:** DIN rail IEC/EN 60 715

**Weight:** 155 g

## Dimensions

**Width x height x depth:** 22,5 x 82 x 99 mm

## Standard type

MK 9151.11 2 ... 450 kΩ AC 220 ... 240 V

Article number: 0044505 stock item

- Output: 1 changeover contact
- Measuring range: 2 ... 450 kΩ
- Auxiliary voltage  $U_H$ : AC 220 ... 240 V
- Width: 22,5 mm

## Variants

MK 9151.\_\_\_/60 CSA approval

MK 9151.\_\_\_/001: time delay on Min level

MK 9151.\_\_\_/002: time delay on Max level

MK 9151.\_\_\_/400: with sealable transparent cover

MK 9151.\_\_\_/106: with save separation according to VDE 0106

## Ordering example for Variants

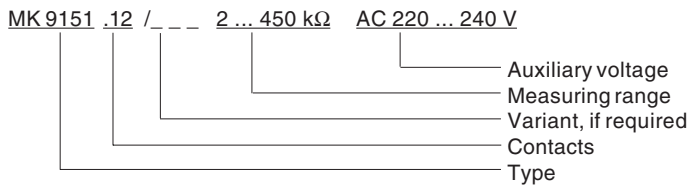

## Accessories

OA 5640: Standard probe

## Applications

