

# Hochgenauer Umgebungslichtsensor mit I<sup>2</sup>C Bus Schnittstelle

## High Accuracy Ambient Light Sensor with I<sup>2</sup>C Bus Interface

### Lead (Pb) Free Product - RoHS Compliant

**SFH 5712**

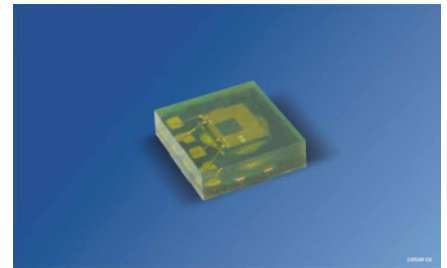

**preliminary datasheet**

#### Wesentliche Merkmale

- Gut an die Augenempfindlichkeit ( $V_\lambda$ ) angepasst
- Hohe Genauigkeit von 3 - 65.000lx
- I<sup>2</sup>C Bus Schnittstelle  
100kbit/s; 400kbit/s; 1.0 Mbit/s und 3.4 Mbit/s
- Niedriger Temperaturkoeffizient der Fotoempfindlichkeit

#### Anwendungen

für Consumer und Mobilegeräte

- Umgebungslicht Messung
- Steuerung von Displayhinterleuchtungen
- Sonnenlicht Sensor

#### Features

- Good match to Human Eye Sensitivity ( $V_\lambda$ )
- High accuracy from 3 - 65.000lx
- I<sup>2</sup>C bus Interface  
100kbit/s; 400kbit/s; 1.0 Mbit/s und 3.4 Mbit/s
- Low temperature coefficient of photosensitivity

#### Applications

for consumer and mobile applications

- Ambient light measurement
- Control of display backlighting
- Sunlight sensor

Typ Type	Bestellnummer Ordering code	Digitaler Ausgang, $E_v=1000lx$ , (white LED) Digital out Out
SFH 5712-2/3 <sup>1)</sup>	Q65110A8485	500-1600

<sup>1)</sup> Nur eine Gruppe innerhalb einer Verpackungseinheit (Streuung kleiner als 2:1)  
Only one bin within one packing unit (variation lower 2:1)

## Application diagram and basic operation

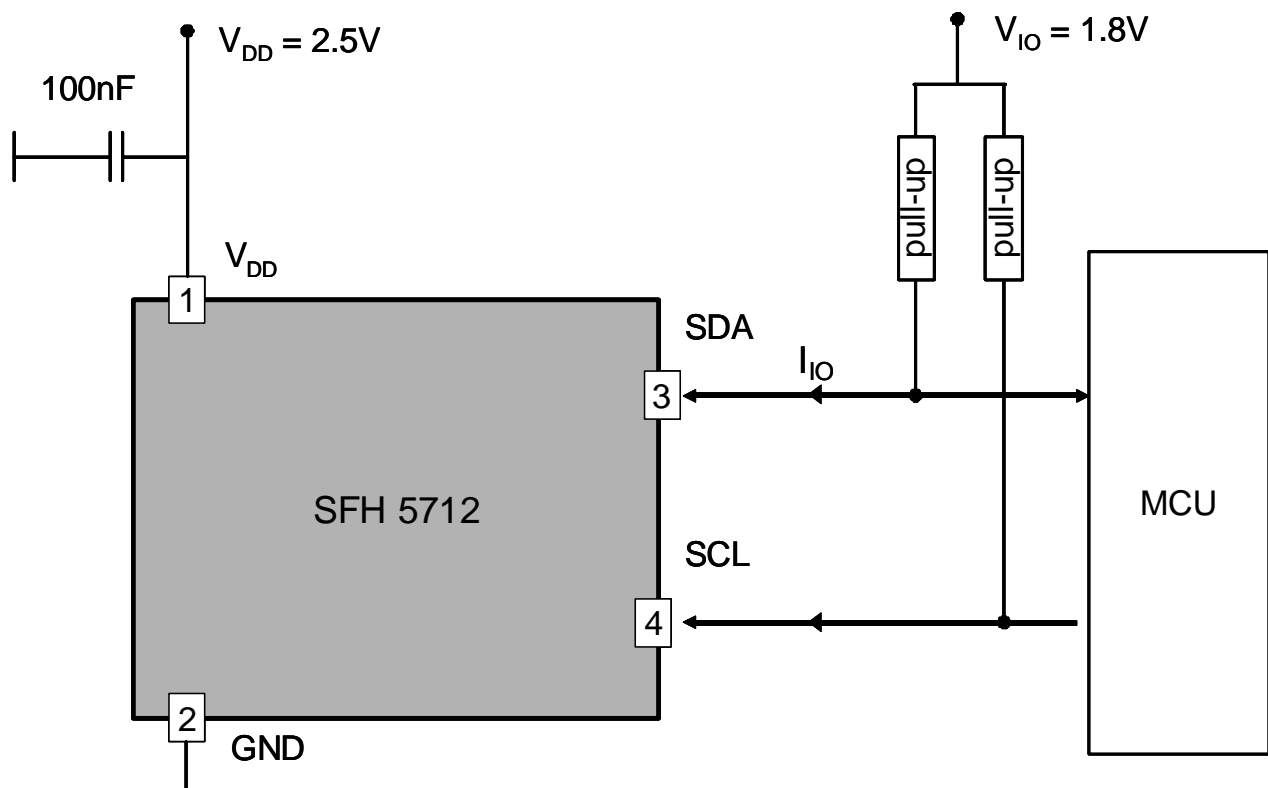

Proposed size for the pull-up resistor is 560W

## Basic operation

Register address	Command	Action
	switch V <sub>DD</sub> on	
	Wait >1ms	
0x80	Write 03	Ambient Light Sensor in ACTIVE mode
	Wait >250 ms	
0x8C	Read data	read LSB data from ambient light measurement (LSB = least significant Byte of 16bit output)
0x8D	Read data	read MSB data from ambient light measurement (MSB = most significant Byte of 16bit output)
0x80	Write 00	Ambient Light Sensor in STAND-BY mode

## Addressing for basic operation

S	Address 0x29	W	A	Register 0x80	A	0x03	A	P
---	--------------	---	---	---------------	---	------	---	---

S	Address 0x29	W	A	Register 0x8C	A	P
---	--------------	---	---	---------------	---	---

S	Address 0x29	R	A	LSB DATA	NA	P
---	--------------	---	---	----------	----	---

S	Address 0x29	W	A	Register 0x8D	A	P
---	--------------	---	---	---------------	---	---

S	Address 0x29	R	A	MSB DATA	NA	P
---	--------------	---	---	----------	----	---

S	Address 0x29	W	A	Register 0x80	A	0x00	A	P
---	--------------	---	---	---------------	---	------	---	---

 Communication from master to SFH 5712

 Communication from SFH 5712 to master

W= Master writes

R = Master reads

A = acknowledge

LSB = least significant byte

NA= not acknowledge

S = START condition

P = STOP condition

MSB = most significant byte

## I<sup>2</sup>C interface

- 1.8V IO-logic level for SDA and SCL
- IO-pins are open drain type and logic high level is set with external pull-up resistor
- SFH 5712-1/2 operates always as slave, address is 0x29 (7bits). Bit 0 is used to change between Read (R/W bit =1) and Write mode (R/W bit =0)..

Address 0x29									
Bit	7	6	5	4	3	2	1	0	
	Address							R/W bit	
default	0	1	0	1	0	0	1	X	

- Designed for the I<sup>2</sup>C-High Speed modes (3.4Mbit/s)
- see I<sup>2</sup>C Bus specification UM10204 from NXP for detailed information
- Spikes up to 10 ns are suppressed on SDA & SCL

## Modes

OFF	If $V_{DD} = 0$ or not connected the device is inactive. Other units may use the I2C bus without any restrictions; I/O pins are in Z state.
STAND-BY	This is the initial mode after power-up. $I_{DD}$ is below $2.5\mu\text{A}$ . No measurement is performed. Only register 0x80 can be read and written. Device can be activated by I <sup>2</sup> C bus communication.
ACTIVE	Measurements are triggered internally by SFH5712. The measurement repetition rate is 2/s. Measurement results can be read from the data register

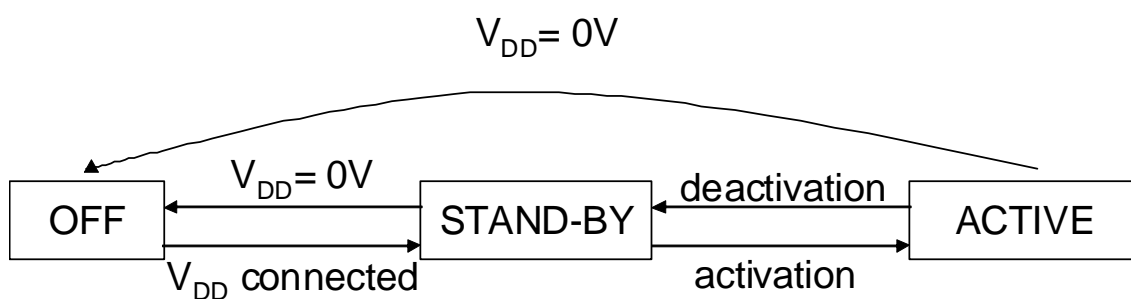

**Maximum Ratings**

Parameter	Symbol	Value	Unit
Storage temperature	$T_{stg}$	- 40 ... + 85	°C
Supply voltage	$V_{DD}$	-0.3 ... +4.5	V
I <sup>2</sup> C - Bus voltage	$V_{IO}$	-0.3 ... +2.5	V
Electrostatic discharge Human Body Model according to EOS/ESD-5.1-1993	$ESD_{hbm}$	2	kV
Electrostatic discharge charge device model according to JEDEC JESD22-C101D	$ESD_{cdm}$	500	V

**Operating Conditions**

Parameter	Symbol	Value			Unit
		min.	typ.	max.	
Operating temperature	$T_{op}$	-15		70	°C
Supply voltage	$V_{DD}$	2.3		3.0	V
Supply voltage ripple (frequency: 0...100Mhz, sinus wave)	$dV_{DD}$			100	mV
Digital output range	$Out$	3		65k	counts
I <sup>2</sup> C - Bus voltage	$V_{IO}$	1.6		2.0	V
Output current „Low“ <sup>1)</sup>	$I_{IO}$	3		12	mA

<sup>1)</sup> FAST MODE PLUS: requirement of  $I_{out\_low}$  20mA is not met.

## Characteristics

Parameter	Symbol	Value			Unit
		min.	typ.	max.	
Mean current consumption <i>ACTIVE mode</i> , $E_V = 0\text{lx}$ , $V_{DD} = 2.5\text{ V}$	$I_{DD}$		145	200	$\mu\text{A}$
Mean current consumption <i>ACTIVE mode</i> , $E_V = 1000\text{lx}$ , $V_{DD} = 2.5\text{ V}$	$I_{DD}$		170		$\mu\text{A}$
Mean current consumption <i>STAND-BY mode</i> , $V_{DD} = 2.5\text{ V}$	$I_{DD}$			2.5	$\mu\text{A}$
Spectral range of sensitivity	$\lambda_{20\%}$		400 ... 680		nm
Wavelength of max. photosensitivity	$\lambda_{s\text{ max}}$		500		nm
Dimensions of radiant sensitive area	$L \times W$		0.4 x 0.4		mm x mm
I <sup>2</sup> C power up time after V <sub>DD</sub> "ON" (see Appendix 1: flicker reduction and timing)	$t_{\text{on}}$		40		$\mu\text{s}$
Output update time for first measurement (see Appendix 1: flicker reduction and timing)	$t_{\text{upd}}$		1	1.5	ms
Resolution of the digital output signal (3lx ... 65klx)	<i>Out</i>		1		count/lx
Digital output signal variation for $V_{DD} = V_{DD, \text{min}}$ to $V_{DD, \text{max}}$ ; $E_V = 1000\text{lx}$			$\pm 10$		counts
Deviation from linear output characteristics <sup>1)</sup> X = 100-65klx X = 10-100lx X = 3-10lx	$f_{\text{lin}}$		$\pm 5$ $\pm 10$ $\pm 20$		%
Temperature coefficient of the output signal $T_{\text{op}} = 0...50^\circ\text{C}$ $T_{\text{op}} = -15...0^\circ\text{C}$ & $50...70^\circ\text{C}$ (1000lx; Norm light A)	$TC_{EV}$		<0.2 <0.25		%/K
Flicker reduction at the output (noise frequency: 50...60Hz) (see Appendix 1: flicker reduction and timing)			13		dB

1) The deviation of the linear output characteristic is referenced to 1000lx and follows the formula:

$$f_{\text{lin}} = \left( \frac{Y_X}{Y_{1000\text{lx}}} \times \frac{1000\text{lx}}{X} - 1 \right) \times 100\%$$

X: sensor illumination level in lux

$Y_X$ : sensor output / measurement value at illumination level X

$Y_{1000\text{lx}}$ : sensor output / measurement value at illumination level 1000lx

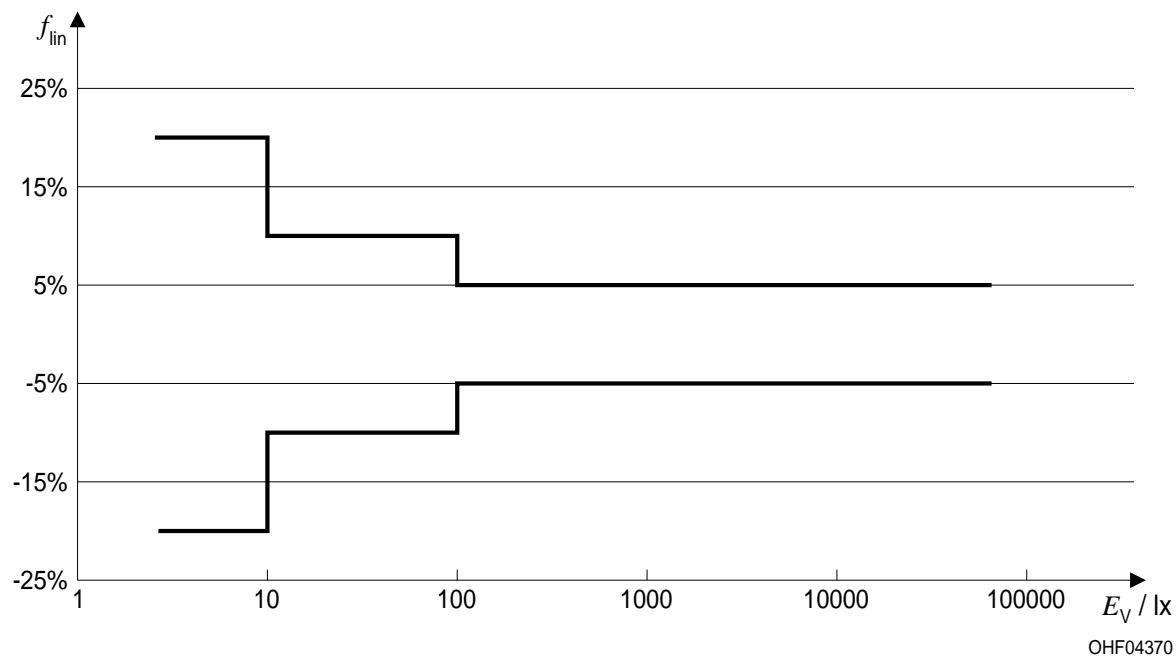

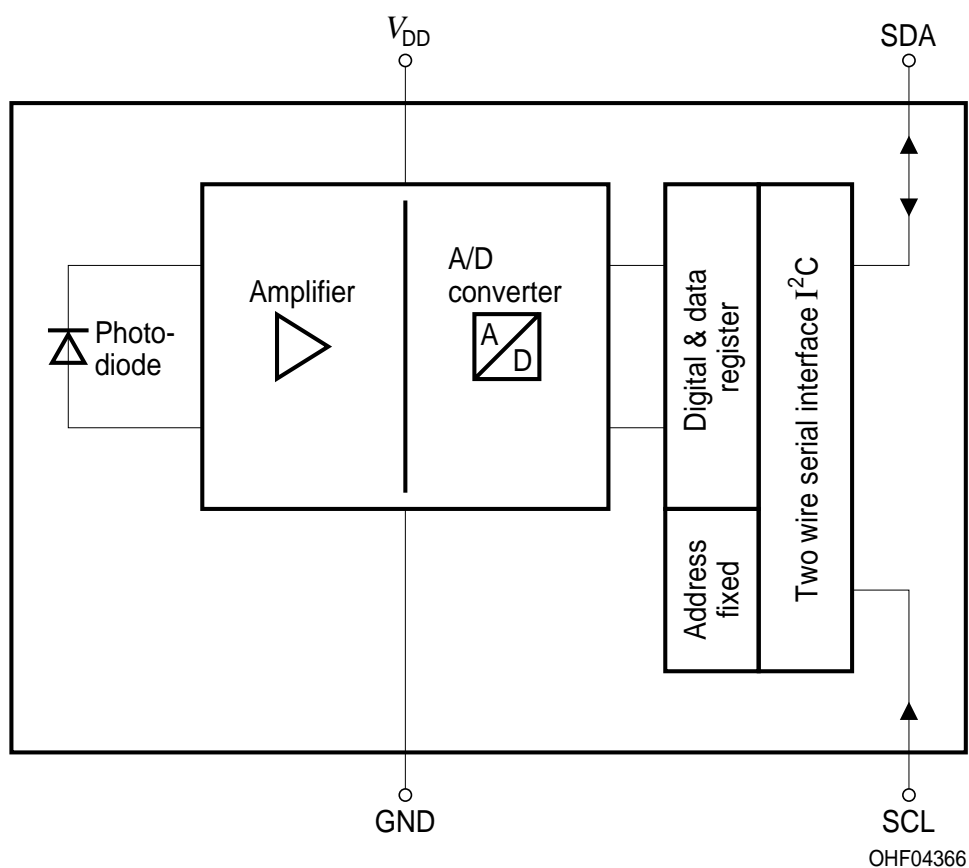

**Figure 1**      **Circuitry**

#### Pin functions

Pin	Description
$V_{DD}$	supply voltage
GND	ground
SCL	I <sup>2</sup> C bus clock serial I/O terminal (SCL)
SDA	I <sup>2</sup> C bus serial data I/O terminal (SDA)

#### Binning ( $T_A = 25\text{ °C}$ )

Parameter	Symbol	Value		Unit
		-2	-3	
Output signal $E_V = 1000\text{lx}$ (white LED LW 541C)	<i>Out</i>	500...1000	800...1600	count

**Relative Spectral Sensitivity**

$S_{rel} = f(\lambda); T_A = 25\text{ }^\circ\text{C}$

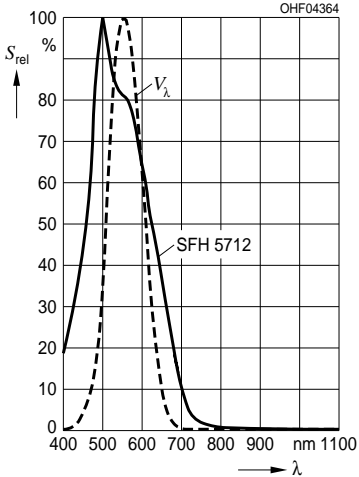

**Directional Characteristics**

$S_{rel} = f(\phi); T_A = 25\text{ }^\circ\text{C}$

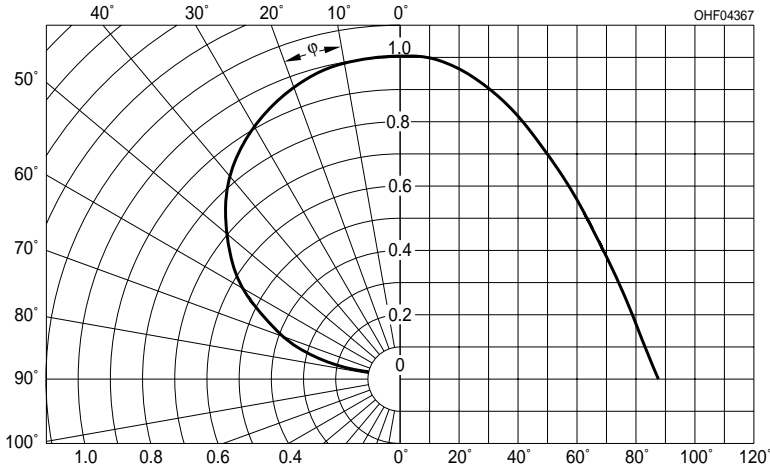

**Output**

$Out = f(E_V); T_A = 25\text{ }^\circ\text{C}$

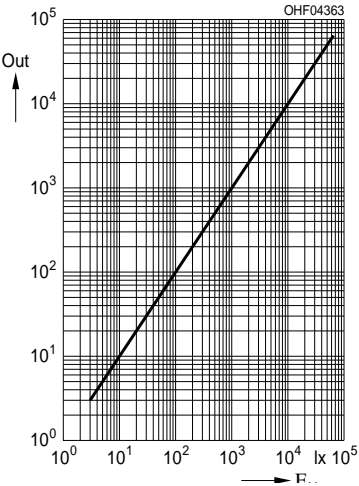

**Current Consumption**

$I_{DD} = f(V_{DD}); T_A = 25\text{ }^\circ\text{C}; V_{DD} = 2.5\text{V};$   
ACTIVE mode

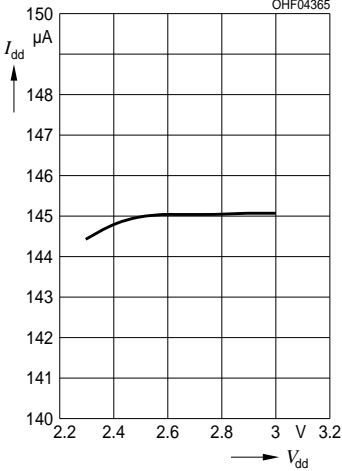

## Appendix 1: Flicker reduction and timing

Sensor is smoothing the output signal by averaging up to 32 single measurements. Flicker caused by artificial light sources e.g. from fluorescent lamps usually occurs at 100Hz or 120Hz. Oscillation of the optical input signal will be reduced by 13dB at the output for sinus signals. E.g. the sensor output variation will only be 5% of the optical input peak to peak variation from fluorescent light. The flicker reduction is calculated by the relative variation of the optical input signal ( $a/A$ ) compared to the sensor output ( $b/B$ ), see figure 2.

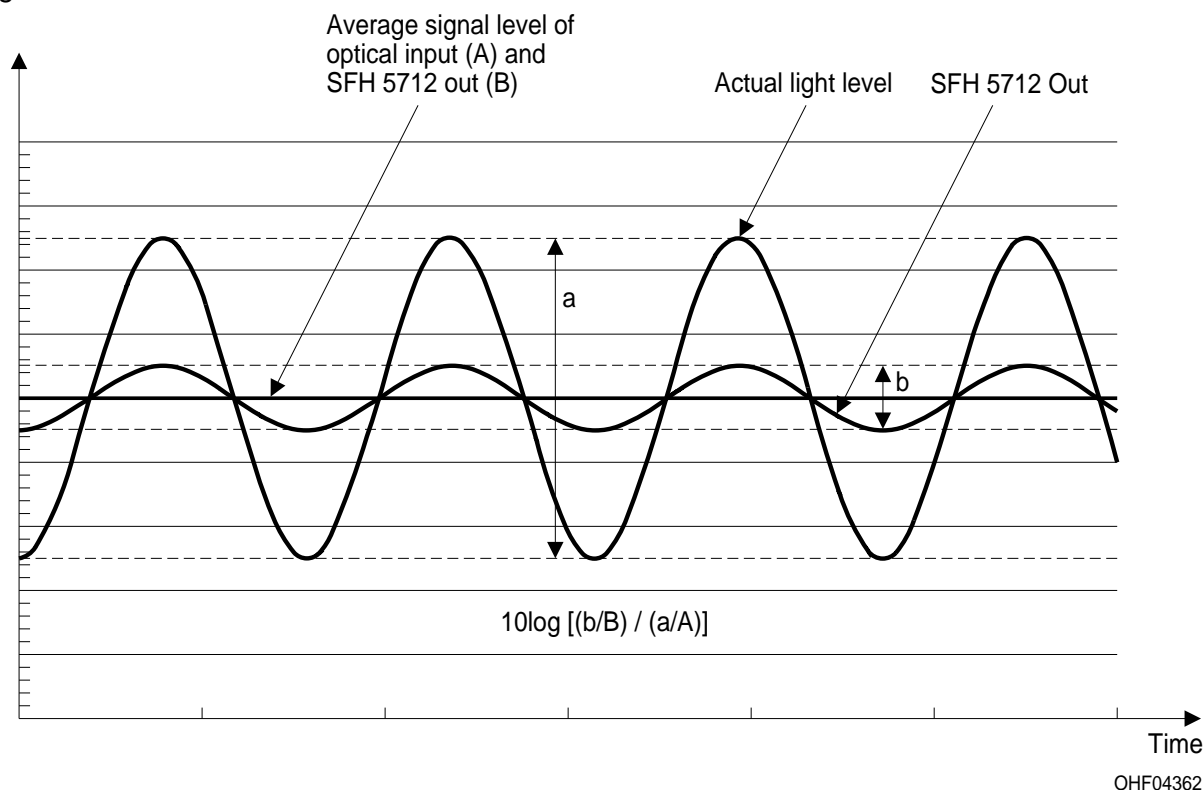
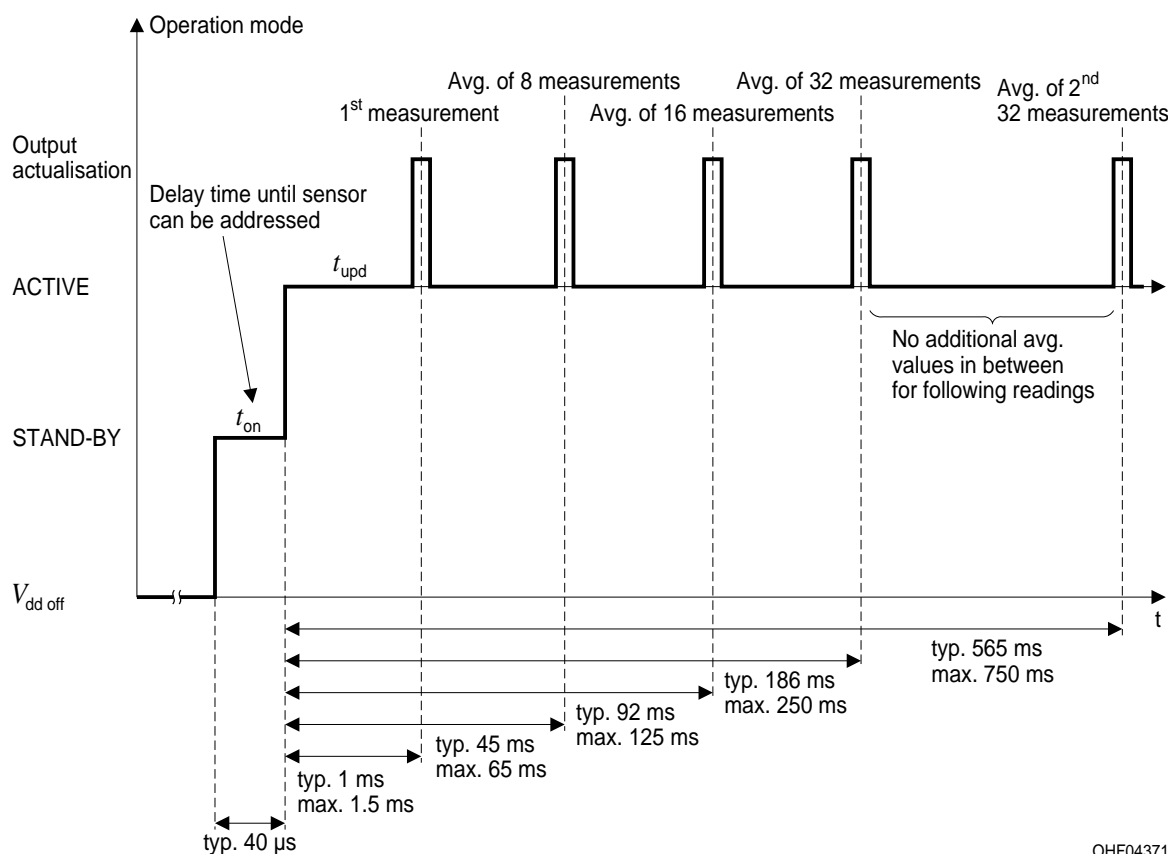

**Figure 2 flicker reduction (average of 32 measurements)**

To achieve the maximum flicker reduction performance the 32fold averaged output value should be used. Typically 186ms (max. 250ms) after sensor activation the first full averaged signal can be read at the sensor output. The sensor allows to read intermediate signal output values prior to 250ms (see figure 3):

- single measurement after typ. 1ms
- average of 8 measurements after typ 45ms
- average of 16 measurements after typ 92ms

After the first full averaged measurement value ( $t > 250\text{ms}$ ) the output will be refreshed automatically twice a second with 32fold averaged values. Single, 8 and 16fold averaged measurements are only performed after activation of the sensor.



OHF04371

**Figure 3: SFH 5712 averaging and timing**

## Appendix 2: Digital Interface characteristics

Interface and control is accomplished through a two-wire I<sup>2</sup>C bus serial interface. The sensor works in multi-master/multi-slave environment, multiple devices may be connected to the same bus. The device conforms to I<sup>2</sup>C interface specification version 3.0 Rev. 03 dated 19 June 2007.

<http://www.standardics.nxp.com/support/documents/i2c/pdf/ics.bus.specification.pdf>

The device implements the I<sup>2</sup>C write protocol as well as the I<sup>2</sup>C read (combined mode) protocol. In block read mode (as slave) the device will transmit registers in a cyclic manner until master issues a stop condition. E.g. if host uses block read and starts from register Ch, slave will return the following sequence of register values:

Ch, Dh, 0h, Ah, Bh, Ch, Dh, 0h,....

until host issues a stop condition.

The address counter always increases the register address after output of register content. This is also valid, if the device is powered down (stand-by mode) between readings.

## Control of ambient light sensor modes

R/W-Register 0x80								
Bit	7	6	5	4	3	2	1	0
	not used					mode of ambient lightsensor		
default	00000					00 STAND-BY		
						00 STAND-BY		
						11 ACTIVE		

## Part number and revision identification

R-Register 0x8A									
Bit	7	6	5	4	3	2	1	0	
	Part number ID					Revision ID			
	1000					XXXX (start with 0001)			

## Manufacturer identification

R-Register 0x8B								
Bit	7	6	5	4	3	2	1	0
	Manufacturer Identification							
	0000				0011			

## Ambient light measurement data (LSB 8bit)

R-Register 0x8C								
Bit	7	6	5	4	3	2	1	0
	LSB data							
default	00000000							

## Ambient light measurement data (MSB 8bit)

R-Register 0x8D								
Bit	7	6	5	4	3	2	1	0
	MSB data							
default	00000000							

The result of the ambient light sensor is a 16bit word split in MSB and LSB and is stored in two registers. The upper byte data registers can only be read following a read to the corresponding lower byte register. When the lower byte register is read, the upper byte is stored in a temporary register, which is read by a

---

subsequent read to the upper byte register. The upper register will contain the correct value even if additional integration cycles end between the reading of the lower and upper registers.

**Example:**

LSB data and MSB data need to be combined to a 16bit word as follows:

LSB data = 0xF0 (1111 0000)

MSB data = 0x83 (1000 0011)

-> in hex: out = 83F0 = 33776 counts

-> in binary: out= 1000 0011 combined with 1111 0000: 1000 0011 1111 0000 = 33776 counts

**I2C bus address**

7 bit sensor address

binary: 0101001 / hex: 29

If the I<sup>2</sup>C bus master sends a not specified register address (e.g. Eh see table 1), the device (slave) will not send ACKNOWLEDGE and go to an idle mode and wait for another command.

## Package Outlines

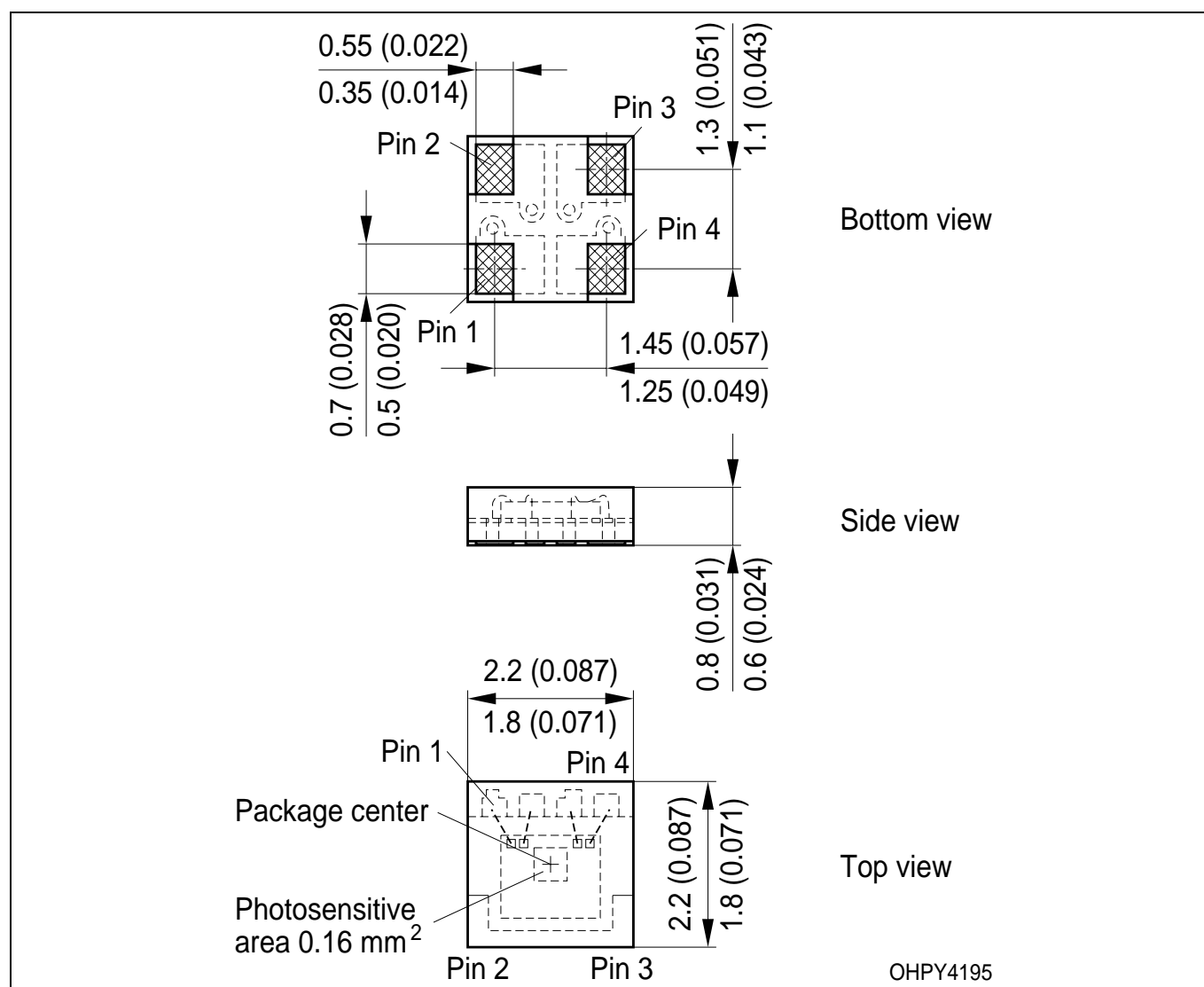

Dimensions in mm (inch)

## Pin configuration

Pin #	Description
1	V <sub>DD</sub>
2	GND
3	SDA
4	SCL

**Recommended Solderpad Design**

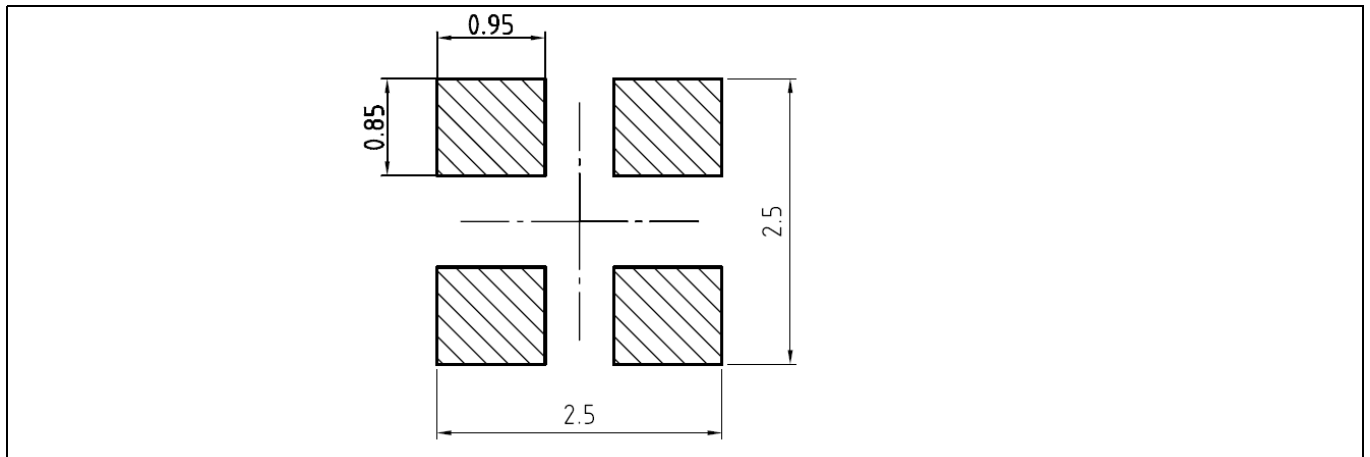

Dimensions in mm

**Taping**

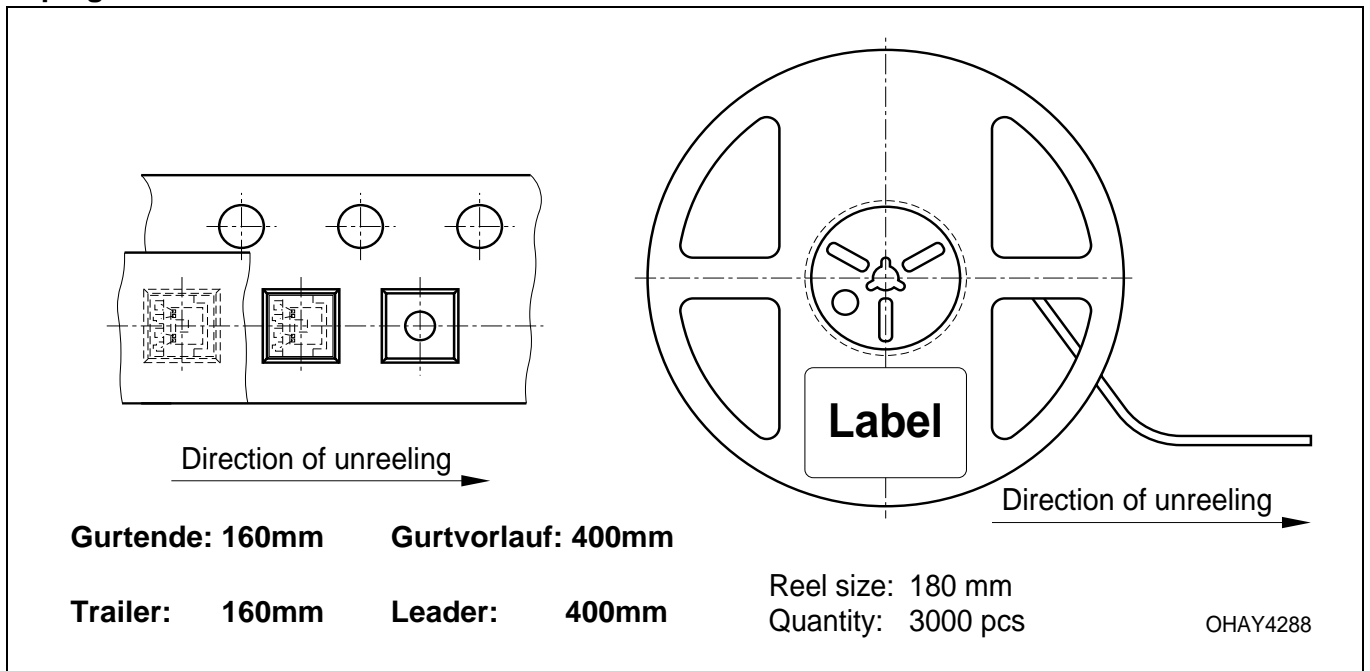

**Soldering Conditions****Reflow Soldering Profile for lead free soldering**

Preconditioning acc. to JEDEC Level 3

(acc. to J-STD-020C)

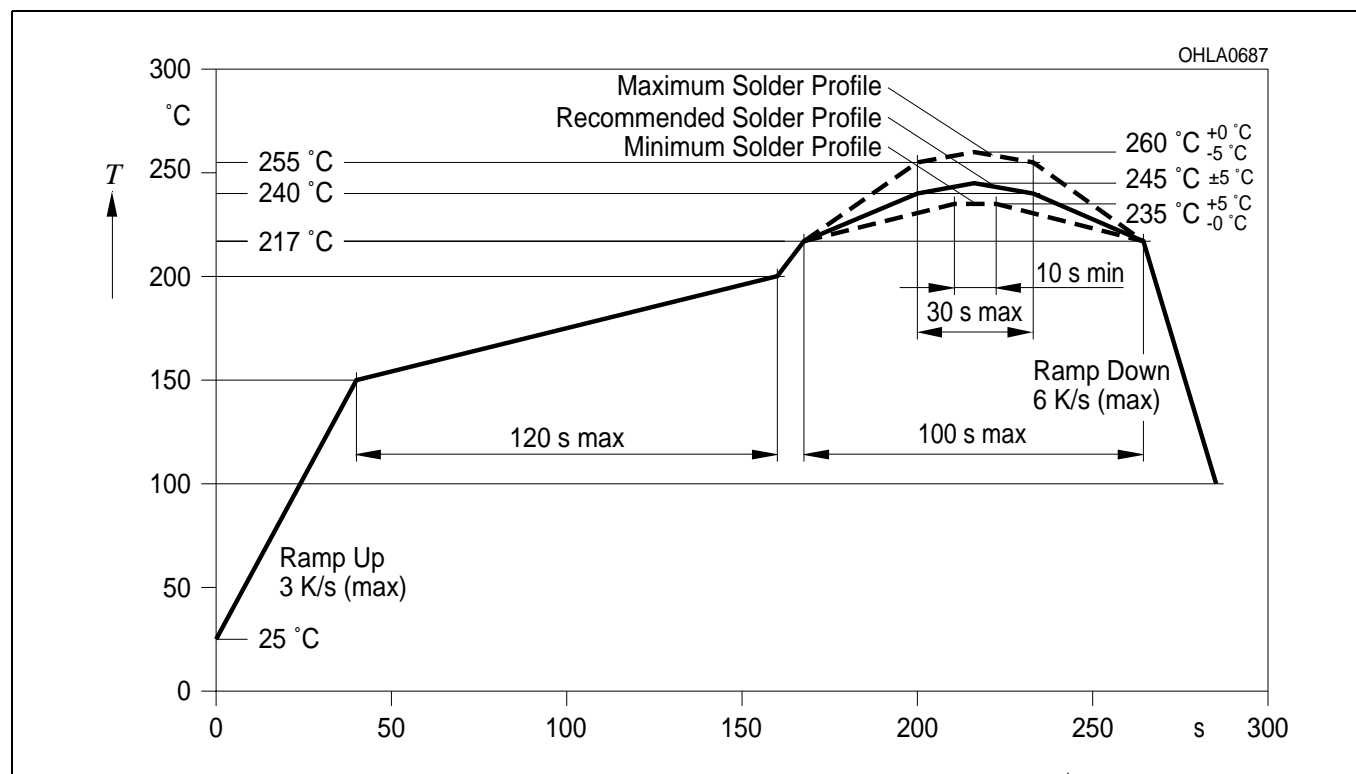

Published by  
**OSRAM Opto Semiconductors GmbH**  
 Leibnizstrasse 4, D-93055 Regensburg  
[www.osram-os.com](http://www.osram-os.com)

© All Rights Reserved.

The information describes the type of component and shall not be considered as assured characteristics.

Terms of delivery and rights to change design reserved. Due

to technical requirements components may contain dangerous substances. For information on the types in question please contact our Sales Organization.

**Packing**

Please use the recycling operators known to you. We can also help you – get in touch with your nearest sales office. By agreement we will take packing material back, if it is sorted. You must bear the costs of transport. For packing material that is returned to us unsorted or which we are not obliged to accept, we shall have to invoice you for any costs incurred.

**Components used in life-support devices or systems must be expressly authorized for such purpose!** Critical components<sup>1</sup>, may only be used in life-support devices or systems<sup>2</sup> with the express written approval of OSRAM OS.

<sup>1</sup> A critical component is a component used in a life-support device or system whose failure can reasonably be expected to cause the failure of that life-support device or system, or to affect its safety or effectiveness of that device or system.

<sup>2</sup> Life support devices or systems are intended (a) to be implanted in the human body, or (b) to support and/or maintain and sustain human life. If they fail, it is reasonable to assume that the health of the user may be endangered.

EU RoHS and China RoHS compliant product



此产品符合欧盟 RoHS 指令的要求；

按照中国的相关法规和标准，不含有毒有害物质或元素。