

Signal conditioner - MINI MCR-SL-U-I-0-SP - 2813570

Please be informed that the data shown in this PDF Document is generated from our Online Catalog. Please find the complete data in the user's documentation. Our General Terms of Use for Downloads are valid (<http://phoenixcontact.com/download>)



MCR 3-way isolating amplifier, for electrical isolation of analog signals, with spring-cage connection, input signal: 0 V ... 10 V, output signal: 0 mA ... 20 mA

Illustration shows the product MINI MCR-SL-U-I-O

Why buy this product

- ✓ Power supply possible via the foot element (TBUS)
- ✓ Entry-level alternative to configurable signal conditioners
- ✓ Low power consumption
- ✓ Highly-compact isolating amplifier for electrical isolation, conversion, amplification, and filtering of standard analog signals
- ✓ 3-way isolation
- ✓ Fixed signal combinations



Key commercial data

Packing unit	1 pc
GTIN	 4 046356 101936
Weight per Piece (excluding packing)	60.0 g
Custom tariff number	85437090
Country of origin	Germany

Technical data

Note

Utilization restriction	EMC: class A product, see manufacturer's declaration in the download area
-------------------------	---------------------------------------------------------------------------

Dimensions

Width	6.2 mm
Height	93.1 mm
Depth	102.5 mm

Signal conditioner - MINI MCR-SL-U-I-0-SP - 2813570

Technical data

Ambient conditions

Ambient temperature (operation)	-20 °C ... 65 °C
Ambient temperature (storage/transport)	-40 °C ... 85 °C
Degree of protection	IP20

Input data

Configurable/programmable	no
Voltage input signal	0 V ... 10 V
Max. input voltage	30 V
Input resistance of voltage input	approx. 100 kΩ

Output data

Configurable/programmable	no
Current output signal	0 mA ... 20 mA
Max. output current	28 mA
Load/output load current output	≤ 500 Ω

Power supply

Nominal supply voltage	24 V DC
Supply voltage range	19.2 V DC ... 30 V DC (The DIN rail bus connector (ME 6,2 TBUS-2 1,5/5-ST-3,81 GN, Order No. 2869728) can be used to bridge the supply voltage. It can be snapped onto a 35 mm DIN rail according to EN 60715))
Max. current consumption	< 20 mA
Power consumption	< 480 mW

Connection data

Connection method	Spring-cage connection
Conductor cross section solid min.	0.2 mm ²
Conductor cross section solid max.	2.5 mm ²
Conductor cross section AWG/kcmil min.	24
Conductor cross section AWG/kcmil max	12
Conductor cross section stranded min.	0.2 mm ²
Conductor cross section stranded max.	2.5 mm ²
Stripping length	8 mm

General

Maximum transmission error	≤ 0.1 % (of final value)
Maximum temperature coefficient	< 0.01 %/K
Temperature coefficient, typical	< 0.002 %/K
Limit frequency (3 dB)	approx. 100 Hz
Step response (10-90%)	approx. 3.5 ms
Electrical isolation	Basic insulation according to EN 61010
Surge voltage category	II
Pollution degree	2

Signal conditioner - MINI MCR-SL-U-I-0-SP - 2813570

Technical data

General

Rated insulation voltage	50 V AC/DC
Test voltage, input/output/supply	1.5 kV (50 Hz, 1 min.)
Electromagnetic compatibility	Conformance with EMC Directive 2004/108/EC
Noise emission	EN 61000-6-4
Noise immunity	EN 61000-6-2 When being exposed to interference, there may be minimal deviations.
Color	green
Housing material	PBT
Mounting position	any
Assembly instructions	The T connector can be used to bridge the supply voltage. It can be snapped onto a 35 mm DIN rail according to EN 60715.
Conformance	CE-compliant
ATEX	# II 3 G Ex nA IIC T4 Gc X
UL, USA / Canada	UL 508 Recognized
	Class I, Div. 2, Groups A, B, C, D T5 applied for
GL	GL EMC 2 D

EMC data

Designation	Electromagnetic RF field
Standards/regulations	EN 61000-4-3
Typical deviation from the measuring range final value	5 %
Designation	Fast transients (burst)
Standards/regulations	EN 61000-4-4
Typical deviation from the measuring range final value	5 %
Designation	Conducted interferences
Standards/regulations	EN 61000-4-6
Typical deviation from the measuring range final value	5 %

Classifications

eCl@ss

eCl@ss 4.0	27210120
eCl@ss 4.1	27210120
eCl@ss 5.0	27210120
eCl@ss 5.1	27210120
eCl@ss 6.0	27210120
eCl@ss 7.0	27210120
eCl@ss 8.0	27210120

ETIM

ETIM 2.0	EC001485
ETIM 3.0	EC001485

Signal conditioner - MINI MCR-SL-U-I-0-SP - 2813570

Classifications

ETIM

ETIM 4.0	EC001485
ETIM 5.0	EC001485

UNSPSC

UNSPSC 6.01	30211506
UNSPSC 7.0901	39121008
UNSPSC 11	39121008
UNSPSC 12.01	39121008
UNSPSC 13.2	39121008

Approvals

Approvals

Approvals

UL Recognized / cUL Recognized / GL / cULus Recognized

Ex Approvals

ATEX

Approvals submitted

Approval details

UL Recognized

cUL Recognized

GL

cULus Recognized

Drawings

Signal conditioner - MINI MCR-SL-U-I-0-SP - 2813570

Block diagram

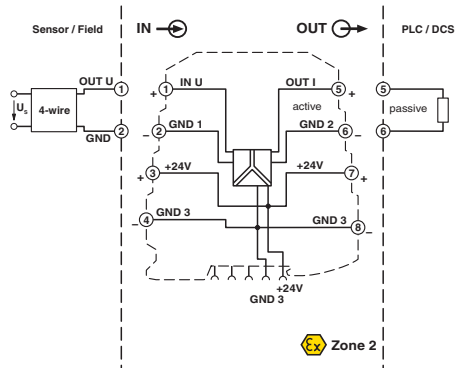

Dimensioned drawing

