

## Automotive Grade AUIR2085S

HIGH SPEED, 100V, SELF OSCILLATING 50%  
DUTY CYCLE, HALF-BRIDGE DRIVER

### Features

- Simple primary side control solution to enable half-bridge DC-Bus Converters for 48V distributed systems with reduced component count and board space
- Integrated 50% duty cycle oscillator & half-bridge driver IC in a single SO-8 package
- Programmable switching frequency with up to 500kHz max per channel
- +/- 1A drive current capability optimized for low charge MOSFETs
- Adjustable dead-time 50ns – 200ns
- Floating channel designed for bootstrap operation up to +100Vdc
- High and low side pulse width matching to +/- 25ns
- Adjustable overcurrent protection
- Undervoltage lockout and internal soft start
- Leadfree, RoHS compliant
- Automotive qualified\*

### Typical Applications

- DC-DC Converters
- HEV Auxiliary Converter
- Battery Management Converters

### Product Summary

Topology	Half-Bridge
$V_{\text{OFFSET}}$	$\leq 100 \text{ V}$
$I_{o+}$ & $I_{o-}$ (typical)	1.0A & 1.0A
$f_{\text{OSC}}$ (max)	500kHz
Deadtime	50ns – 200ns
HO/LO Pulse Matching	+/- 25ns

### Package Options



8 - Lead SOIC  
AUIR2085S

### Typical Connection Diagram

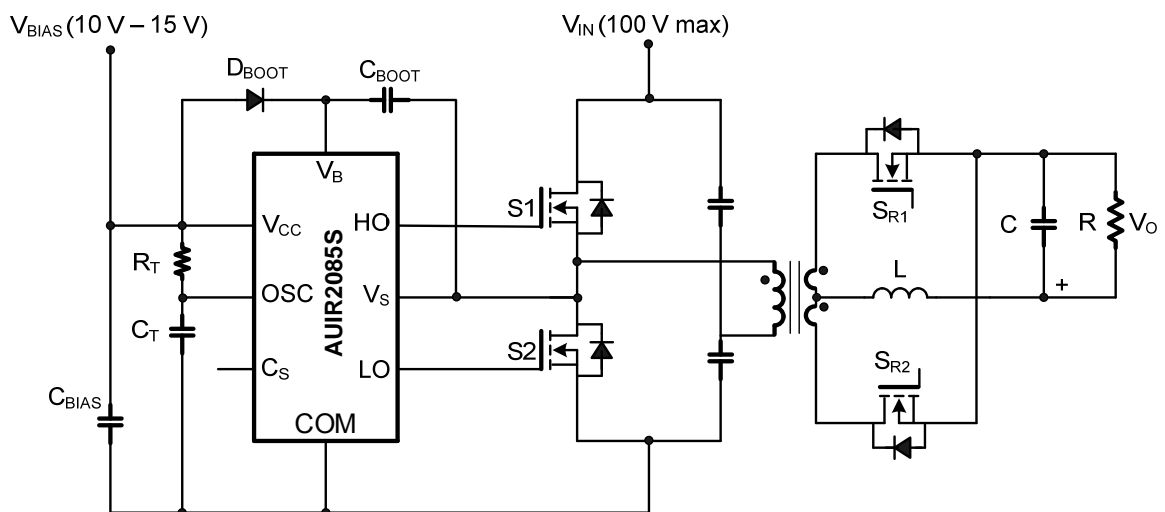

<b>Table of Contents</b>	<b>Page</b>
Typical Connection Diagram	1
Description/Feature Comparison	3
Qualification Information	4
Absolute Maximum Ratings	5
Recommended Operating Conditions	5
Dynamic Electrical Characteristics	6
Static Electrical Characteristics	6
Functional Block Diagram	7
Input/Output Pin Equivalent Circuit Diagram	9
Lead Definitions	10
Lead Assignments	10
Package Details	12
Tape and Reel Details	13
Part Marking Information	14
Ordering Information	15

## Description

The AUIR2085S is a self oscillating half-bridge driver IC with 50% duty cycle ideally suited for 36V – 75V half-bridge DC-bus converters.

This product is also suitable for push-pull converters without restriction on input voltage.

Each channel frequency is equal to  $f_{OSC}$ , which can be set by selecting  $R_T$  &  $C_T$ , where  $f_{OSC} = 1/(2 \cdot R_T \cdot C_T)$ .

Dead-time can be controlled through proper selection of  $C_T$  and can range from 50ns to 200ns.

Internal soft-start increases the pulse width during power up and maintains pulse width matching for the high and low outputs throughout the start up cycle.

Typically soft-start duty cycle varies beginning from 5-10% ramping up to about 50% over 1000 cycles.

The AUIR2085S initiates a soft start at power up and after every overcurrent condition. Undervoltage lockout prevents operation if  $V_{CC}$  is less than 7.5V.

**Qualification Information<sup>†</sup>**

<b>Qualification Level</b>		Automotive (per AEC-Q100 <sup>††</sup> )	
		Comments: This family of ICs has passed an Automotive qualification. IR's Industrial and Consumer qualification level is granted by extension of the higher Automotive level.	
<b>Moisture Sensitivity Level</b>		SOIC8N	MSL3 <sup>†††</sup> 260°C (per IPC/JEDEC J-STD-020)
<b>ESD</b>	Machine Model	Class M2 (+/-200V) (per AEC-Q100-003)	
	Human Body Model	Class H1B (+/-1750V) (per AEC-Q100-002)	
	Charged Device Model	Class C4 (+/-1000V) (per AEC-Q100-011)	
<b>IC Latch-Up Test</b>		Class II, Level B (per AEC-Q100-004)	
<b>RoHS Compliant</b>		Yes	

† Qualification standards can be found at International Rectifier's web site <http://www.irf.com/>

†† Exceptions to AEC-Q100 requirements are noted in the qualification report.

††† Higher MSL ratings may be available for the specific package types listed here. Please contact your International Rectifier sales representative for further information.

### Absolute Maximum Ratings

Absolute Maximum Ratings indicate sustained limits beyond which damage to the device may occur. All voltage parameters are absolute voltages referenced to COM. The thermal resistance and power dissipation ratings are measured under board mounted and still air conditions.

Symbol	Definition	Min.	Max.	Units
$V_B$	High side floating supply voltage	-0.3	150	V
$V_{CC}$	Low side supply voltage	—	25	
$V_S$	High side floating supply offset voltage	$V_B - 25$	$V_B + 0.3$	
$V_{HO}$	High side floating output voltage	$V_B - 0.3$	$V_B + 0.3$	
$V_{LO}$	Low side output voltage	-0.3	$V_{CC} + 0.3$	
OSC	OSC pin voltage	-0.3	$V_{CC} + 0.3$	
$V_{CS}$	$C_S$ pin voltage	-0.3	$V_{CC} + 0.3$	
dVs/dt	Allowable offset voltage slew rate	—	50	V/ns
$I_{CC}$	Supply current	—	20	mA
$P_D$	Package power dissipation @ $T_A \leq 25^\circ\text{C}$	—	0.625	W
$R_{thJA}$	Thermal resistance, junction to ambient	—	200	$^\circ\text{C}/\text{W}$
$T_J$	Junction temperature	—	150	$^\circ\text{C}$
$T_S$	Storage temperature	-55	150	
$T_L$	Lead temperature (soldering, 10 seconds)	—	300	

### Recommended Operating Conditions

For proper operation the device should be used within the recommended conditions.

Symbol	Definition	Min.	Max.	Units
$V_B$	High side floating supply voltage	$V_S + 10$	$V_S + 15$	V
$V_S$	Steady state high side floating supply offset voltage	-5 (†)	100	
$V_{CC}$	Supply voltage	10	15	
$I_{CC}$	Supply current	—	5	mA
$R_T$	Timing resistor	10	100	k $\Omega$
$C_T$	Timing capacitor	47	470	pF
$f_{osc}$	Operating frequency (per channel)	—	500	kHz
$T_A$	Ambient temperature	-40	125	$^\circ\text{C}$

† Care should be taken to avoid output switching conditions where the  $V_S$  node flies inductively below ground by more than 5V.

**Dynamic Electrical Characteristics**

$V_{CC} = V_{BS} = 12V$ ,  $C_{LOAD} = 1000pF$ , and  $T_A = 25^{\circ}C$  unless otherwise specified.

Symbol	Definition	Min	Typ	Max	Units	Test Conditions		
$t_r$	Turn-on rise time	—	40	60	ns	$V_S = 0V$		
$t_f$	Turn-off fall time	—	20	30				
$f_{OSC}$	Per channel output frequency	500	—	—	kHz	$C_T = 100pF$ , $R_T = 10k\Omega$		
$t_{DT}$	HO/LO output dead time	50	—	—				
$t_{DCS}$	Overcurrent shut down delay	—	200	—			ns	Pulse on $C_S$
PM	HO/LO pulse width mismatch	-25	—	25				

**Static Electrical Characteristics**

$V_{CC} = V_{BS} = 12V$ ,  $C_{LOAD} = 1000pF$ , and  $T_A = 25^{\circ}C$  unless otherwise specified.

Symbol	Definition	Min	Typ	Max	Units	Test Conditions
$V_{OH}$	High level output voltage, $V_{CC}$ or $V_{BS} - V_O$	—	—	1.5	V	
$V_{OL}$	Low level output voltage	—	—	0.1		
$I_{leak}$	Offset supply leakage current	—	—	50	$\mu A$	
$I_{QBS}$	Quiescent $V_{BS}$ supply current	—	—	150		
$I_{QCC}$	Quiescent $V_{CC}$ supply current	—	—	1.5	mA	
$V_{CS+}$	Overcurrent shutdown threshold	250	300	350	mV	
$V_{CS-}$	Overcurrent shutdown threshold	150	200	250	mV	
$V_{CCUV+}$	Undervoltage positive going threshold	6.8	7.3	7.8	V	
$V_{CCUV-}$	Undervoltage negative going threshold	6.3	6.8	7.3		
$V_{BSUV+}$	High side undervoltage positive going threshold	6.8	7.3	7.8		
$V_{BSUV-}$	High side undervoltage negative going threshold	6.3	6.8	7.3		
$I_{O+}$	Output high short circuit current	—	1.0	—	A	
$I_{O-}$	Output low short circuit current	—	1.0	—		

**Functional Block Diagram**

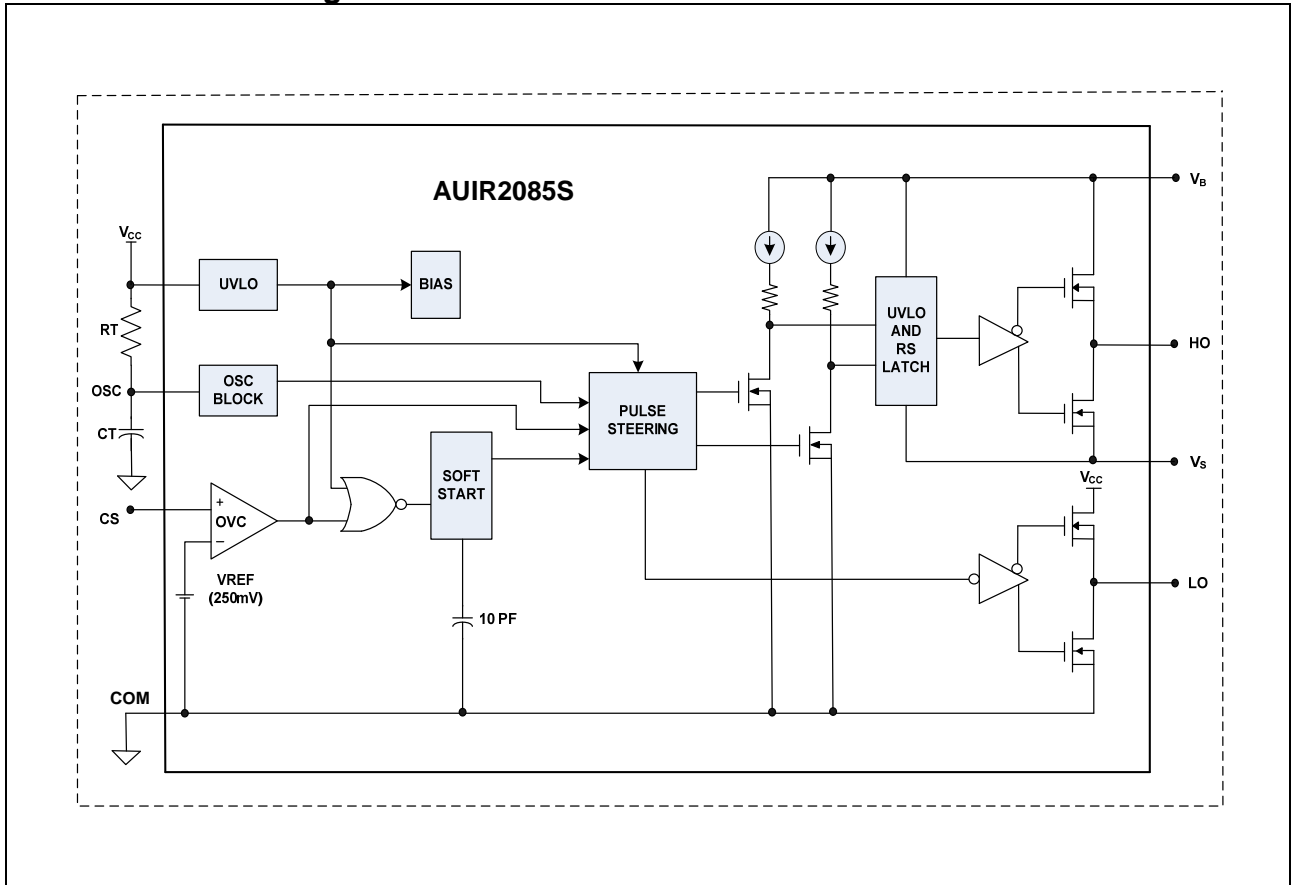

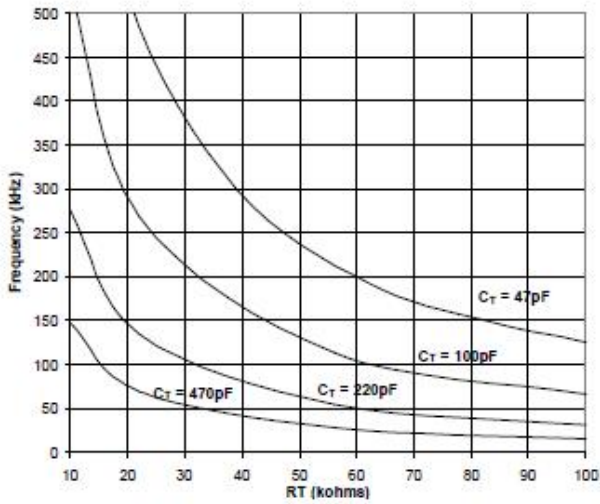

Fig. 1 Typical Output Frequency (-25°C to 125°C)

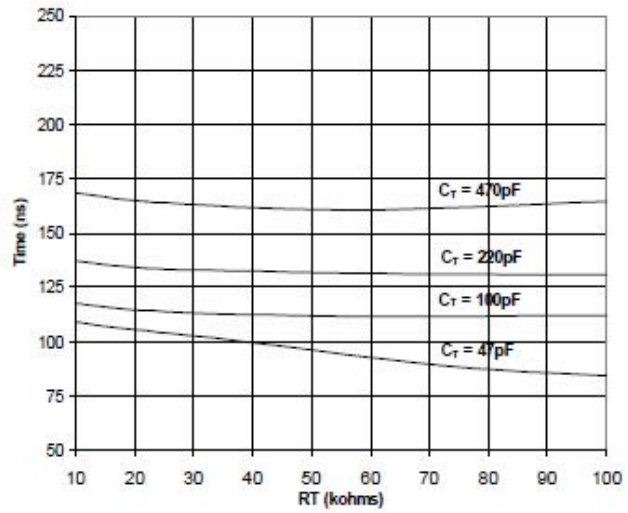

Fig. 2 Typical Dead Time (@25°C)

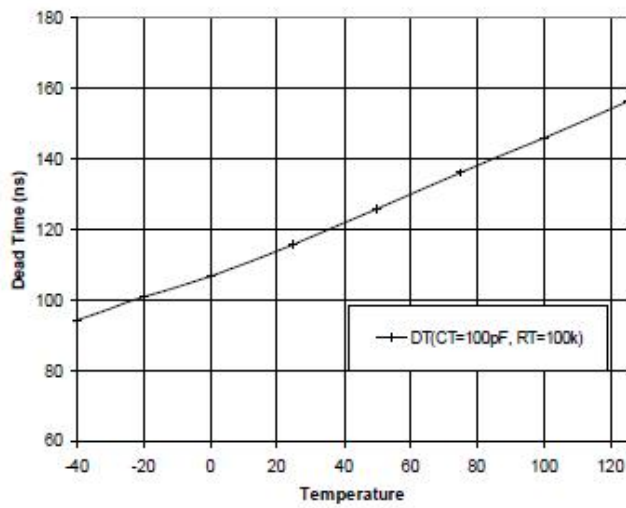
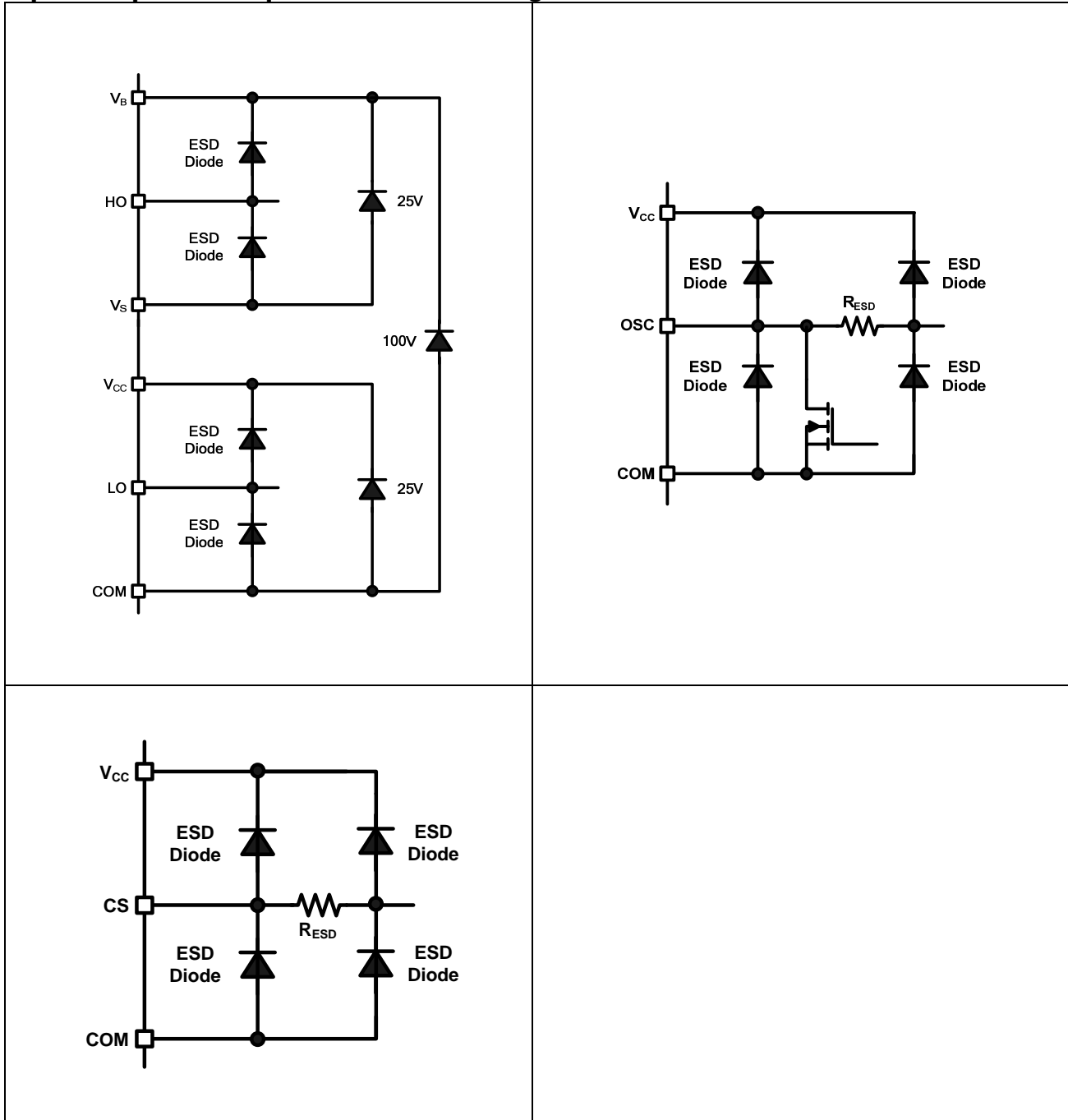

Fig. 3 Typical Dead Time vs Temperature

**Input/Output Pin Equivalent Circuit Diagrams**



**Lead Definitions**

PIN	Symbol	Description
1	CS	Current sense input
2	OSC	Oscillator pin
3	COM	Logic supply return
4	LO	Low side output
5	V <sub>CC</sub>	Logic supply
6	V <sub>S</sub>	Floating supply return
7	HO	High side output
8	V <sub>B</sub>	High side floating supply

**Lead Assignments**

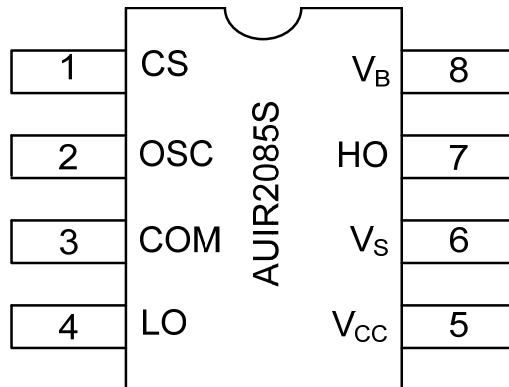

## Pin Descriptions

**Cs:** The input pin to the overcurrent comparator. Exceeding the overcurrent threshold value specified in “Static Electrical Parameters” Section will terminate output pulses and start a new soft start cycle as soon as the voltage on the pin reduce below the threshold value.

**OSC:** The oscillator-programming pin. Only two components are required to program the internal oscillator frequency: a resistor connected between the  $V_{CC}$  pin and the OSC pin, and a capacitor connected from the OSC to COM. The approximate oscillator frequency is determined by the following simple formula:

$$f_{OSC} = 1 / (2 \cdot R_T \cdot C_T)$$

Where frequency is in Hertz (Hz),  $R_T$  resistance in Ohms ( $\Omega$ ) and  $C_T$  capacitance in Farads (F). The recommended range of timing resistors is between 10k $\Omega$  and 100k $\Omega$  and range of time capacitances is between 47pF and 470pF. The timing resistors less than 10k $\Omega$  should be avoided. The value of the timing capacitor determines the amount of dead time between the two output drivers: lower the  $C_T$ , shorter the dead time and vice versa. It is not recommended to use a timing capacitor below 47pF, for best performance keep the timing components physically as close as possible to the AUIR2085S. Separated ground and  $V_{CC}$  traces to the timing components are encouraged.

**COM:** Signal ground and power ground for all functions. Due to high current and high frequency operation, a low impedance circuit board ground plane is highly recommended.

**HO, LO:** High side and low side gate drive pins. The high and low side drivers can directly drive the gate of a power MOSFET. The drivers are capable of 1A peak source and sink currents. It is recommended that the high and low drive pins be very close to the gates of the high side and low side MOSFETs to prevent any delay and distortion of the drive signals.

**V<sub>B</sub>:** The high side power input connection. The high side supply is derived from a bootstrap circuit using a low-leakage Schottky diode and a ceramic capacitor. To prevent noise, the Schottky diode and bypass capacitor should be very close to the AUIR2085S.

**V<sub>S</sub>:** The high side power return connection.  $V_S$  should be connected directly to the source terminal of high side MOSFET with a trace as short as possible.

**V<sub>CC</sub>:** The IC bias input connection for the device. Although the quiescent  $V_{CC}$  current is very low, total supply current will be higher, depending on the gate charge of the MOSFETs connected to the HO and LO pins, and the programmed oscillator frequency, total  $V_{CC}$  current is the sum of quiescent  $V_{CC}$  current and the average current at HO and LO. Knowing the operating frequency and the MOSFET gate charge (Qg) at selected  $V_{CC}$  voltage, the average current can be calculated from:

$$I_{ave} = 2 \times Q_g \times f_{OSC}$$

To prevent noise problem, a bypass ceramic capacitor connected to  $V_{CC}$  and COM should be placed as close as possible to the AUIR2085S.

AUIR2085S has an under voltage lookout feature for the IC bias supply,  $V_{CC}$ . The minimum voltage required on  $V_{CC}$  to make sure that IC will work within specifications must be higher than 8.5V (10V minimum  $V_{CC}$  is recommended to prevent asymmetrical gates signal on HO and LO pins that are expected when  $V_{CC}$  is between 7.5V and 8.5V).

**Package Details:**

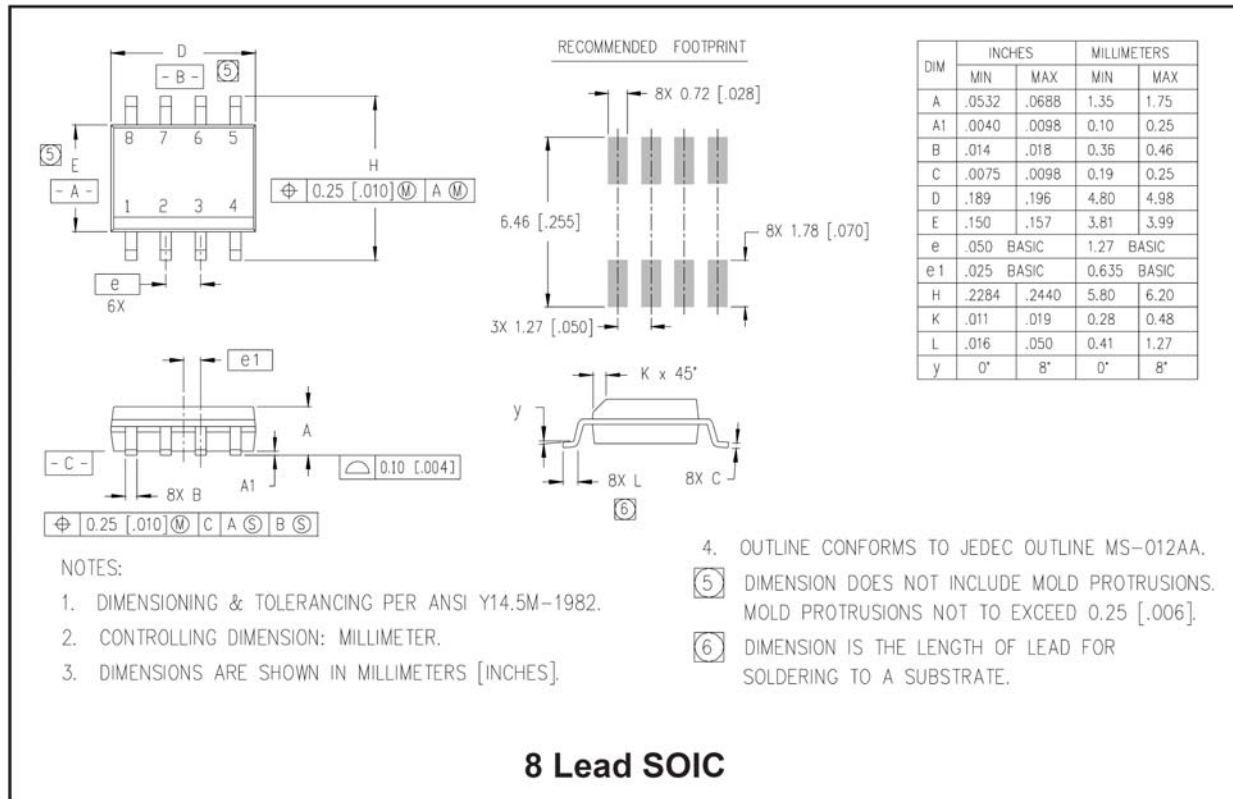

**Tape and Reel Details:**

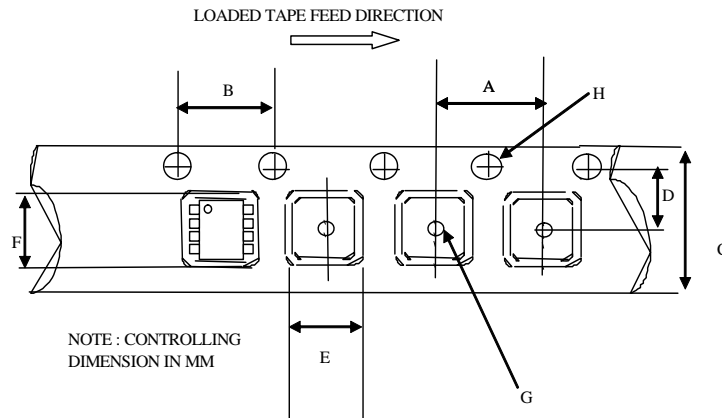

CARRIER TAPE DIMENSION FOR 8SOICN

Code	Metric		Imperial	
	Min	Max	Min	Max
A	7.90	8.10	0.311	0.318
B	3.90	4.10	0.153	0.161
C	11.70	12.30	0.46	0.484
D	5.45	5.55	0.214	0.218
E	6.30	6.50	0.248	0.255
F	5.10	5.30	0.200	0.208
G	1.50	n/a	0.059	n/a
H	1.50	1.60	0.059	0.062

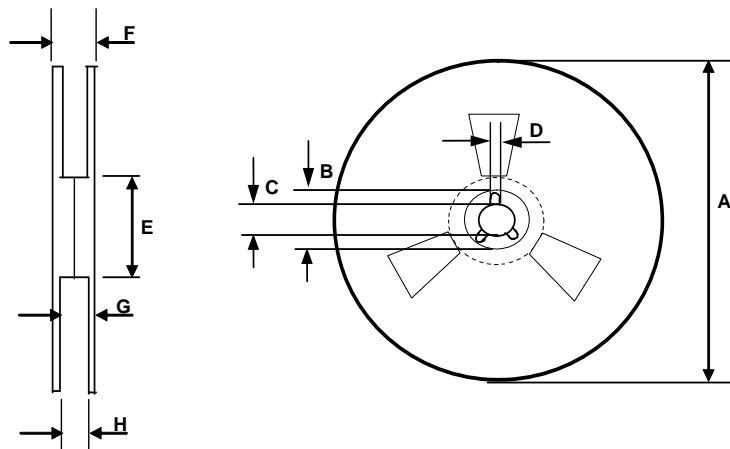

REEL DIMENSIONS FOR 8SOICN

Code	Metric		Imperial	
	Min	Max	Min	Max
A	329.60	330.25	12.976	13.001
B	20.95	21.45	0.824	0.844
C	12.80	13.20	0.503	0.519
D	1.95	2.45	0.767	0.096
E	98.00	102.00	3.858	4.015
F	n/a	18.40	n/a	0.724
G	14.50	17.10	0.570	0.673
H	12.40	14.40	0.488	0.566

**Part Marking Information**

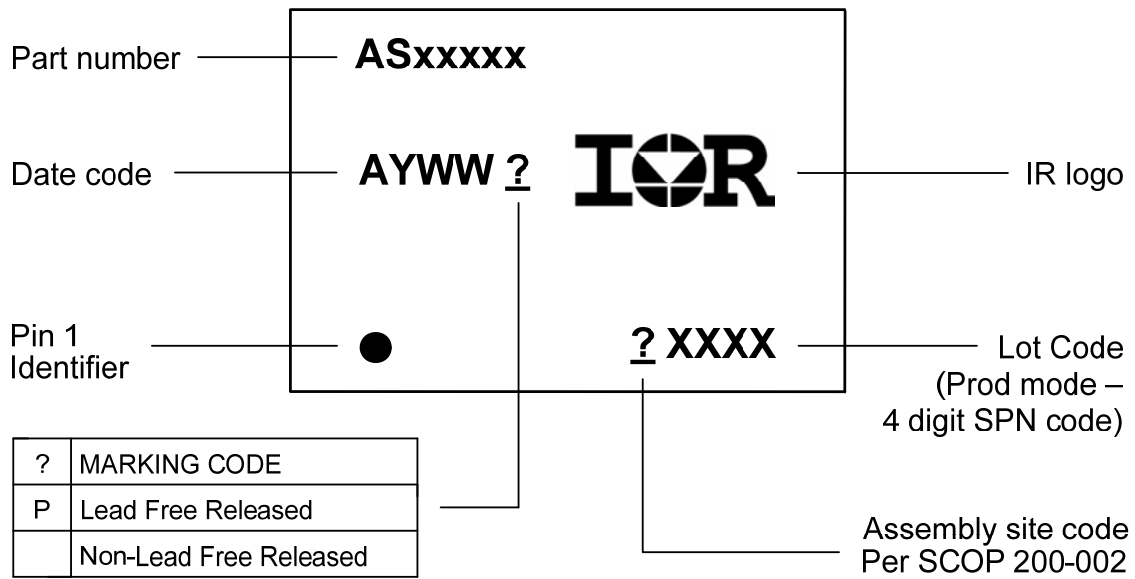

**Ordering Information**

Base Part Number	Package Type	Standard Pack		Complete Part Number
		Form	Quantity	
AUIR2085S	SOIC8	Tube/Bulk	95	AUIR2085S
		Tape and Reel	2500	AUIR2085STR

The information provided in this document is believed to be accurate and reliable. However, International Rectifier assumes no responsibility for the consequences of the use of this information. International Rectifier assumes no responsibility for any infringement of patents or of other rights of third parties which may result from the use of this information. No license is granted by implication or otherwise under any patent or patent rights of International Rectifier. The specifications mentioned in this document are subject to change without notice. This document supersedes and replaces all information previously supplied.

For technical support, please contact IR's Technical Assistance Center  
<http://www.irf.com/technical-info/>

**WORLD HEADQUARTERS:**  
 233 Kansas St., El Segundo, California 90245  
 Tel: (310) 252-7105

**Revision History**

Date	Comment
5/8/08	Created AUIR2085S based on IR2085S
8/21/08	Changed all references to the AUIRS2085S (Gen5) to AUIR2085S (Gen2) Changed all GND references to COM in text/diagrams Several changes to the product summary Changed topology from "3 Phase" to "Half-Bridge" Changed $V_{\text{OFFSET}}$ from 600V to 100V Removed $V_{\text{OUT}}$ reference Included $f_{\text{OSC(max)}}$ of 500kHz Updated Deadtime range, 50ns – 200ns Included HO/LO Pulse Width Matching of +/- 25ns Removed "Typical Applications" section Changed $dV_{\text{S}}/dt$ spec from +/- 50V to just 50V max Updated $P_{\text{D}}$ max from 1W to 0.625W Removed $T_{\text{J}}$ min spec to be consistent with other datasheets Changed recommended $V_{\text{B}}$ spec from $V_{\text{DD}} - 0.7V/15V$ to $V_{\text{S}} + 10V/V_{\text{S}} + 15V$ Changed recommended $T_{\text{J}}$ spec to $T_{\text{A}}$ Renamed $UV_{\text{CC+}}$ to $V_{\text{CCUV+}}$ Renamed $UV_{\text{CC-}}$ to $V_{\text{CCUV-}}$ Renamed $UV_{\text{BS+}}$ to $V_{\text{BSUV+}}$ Renamed $UV_{\text{BS-}}$ to $V_{\text{BSUV-}}$ Added IC label on lead assignment block
12/5/08	Added ESD/LU ratings to qual table Corrected lead assignment dwg (Vs and HO were swapped) Edited lead assignment dwg to align with template
12/11/08	Change from APBU: Added typ application diagram on the first page. Moved typ connection diagram, it from front page to page 3.
1/22/09	Change from APBU: Removed Typ App Diagram and moved Typ connection diagram back to P1. Added Typical Applications on P1
1/28/09	Scott reviewed the datasheet, Preliminary sign removed
1/29/09	Parameter Temperature trends removed
2/6/09	max Timing Capacitor Rec. Op. Cond. Changed from 1000 pF to 470pF. Fig.1, Fig2 and Fig3 added, copied back from IR2085S Added details to soft start description.
7/13/09	Removed P12 (application information) Updated table of contents (renumbering)
9/8/2010	Updated ESD classification