

10031567-001LF - SAS : 29
 Position Vertical SMT
 Receptacle



www.fci.com

Specifications

| General | |
|---------------------------------|---------------------------|
| Number of contacts | 29 |
| Orientation | Vertical |
| Retention Feature | Surface Mount Pad |
| Electrical | |
| Current rating | 1.5A at 30°C |
| Resistance (Contact) | 15 M-ohms max. |
| Resistance (Insulation) | 1000 M-ohms min. |
| Voltage rating | 500V AC |
| Mechanical | |
| Durability (Mating cycles) | 500 Mating Cycles |
| Mounting | |
| Termination | Surface Mount |
| Physical | |
| Color (Housing) | Black |
| Material (Contact) | Copper Alloy |
| Material (Housing) | Thermoplastic (UL 94 V-O) |
| Plating (Contact) | 30u" Gold |
| Temperature (Operating - range) | 260°C max. for 10 Seconds |
| Approvals / Certifications | |
| Approvals / Certifications | UL and CSA Pending |
| Other Features | |
| Packaging (Type) | Tray |
| Type | Receptacle |

PRODUCT NO
SEE TABLE

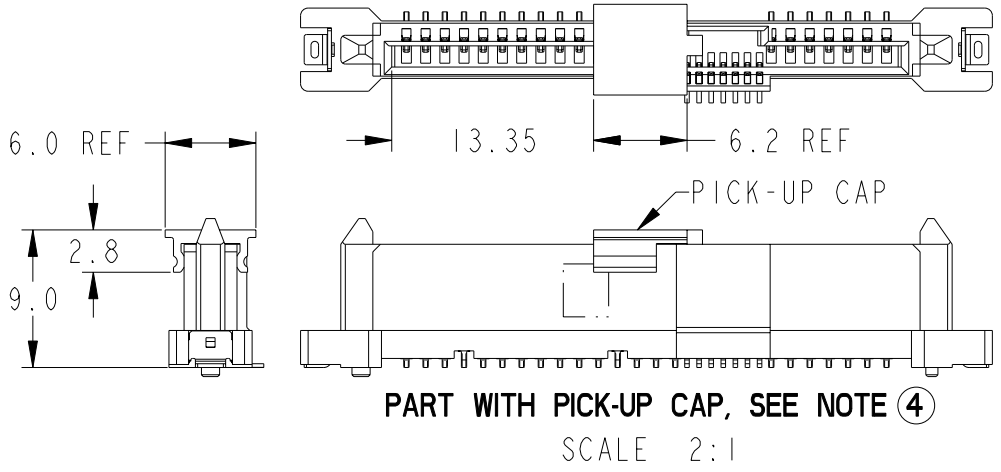
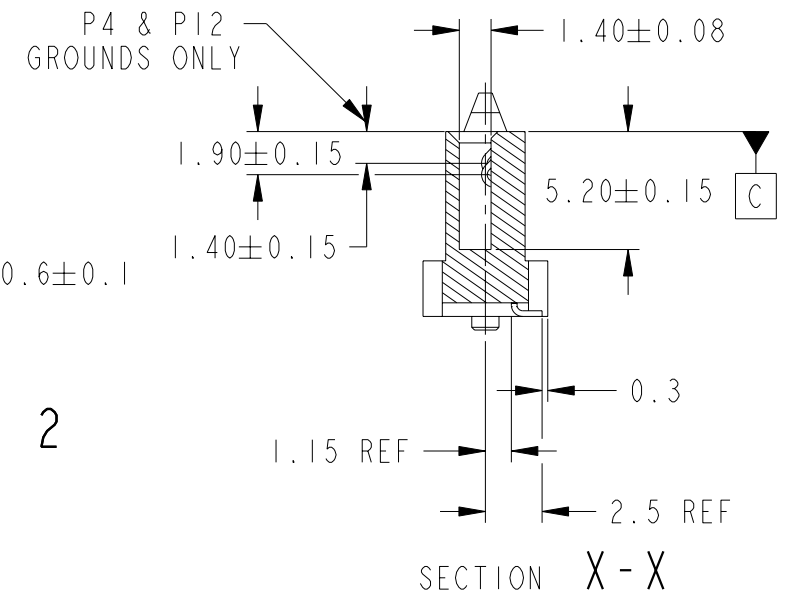
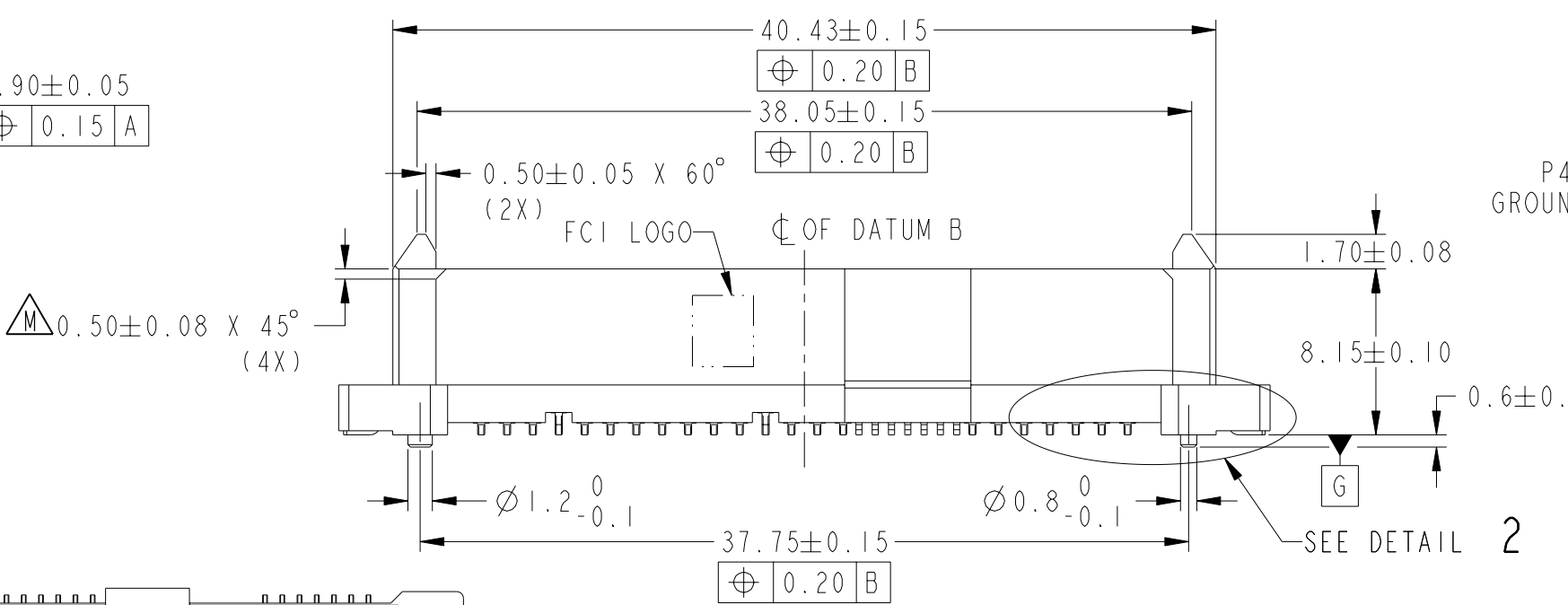
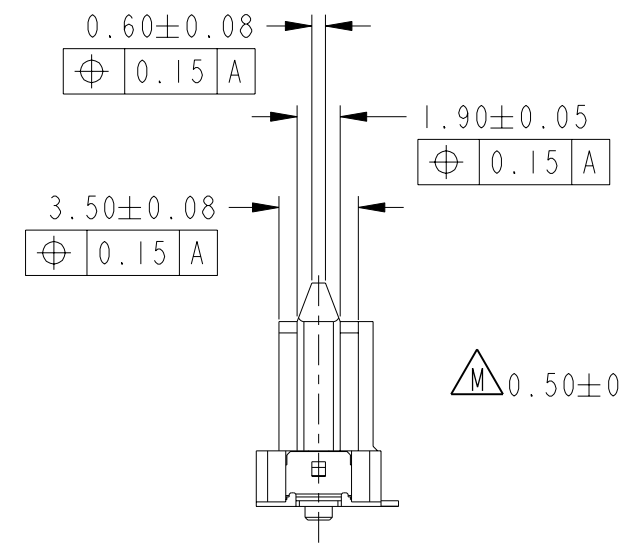
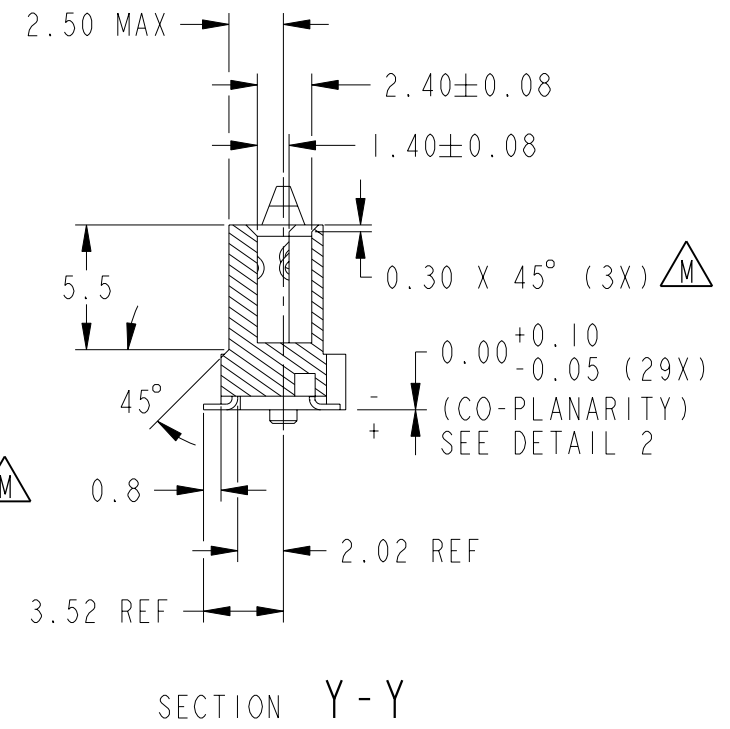
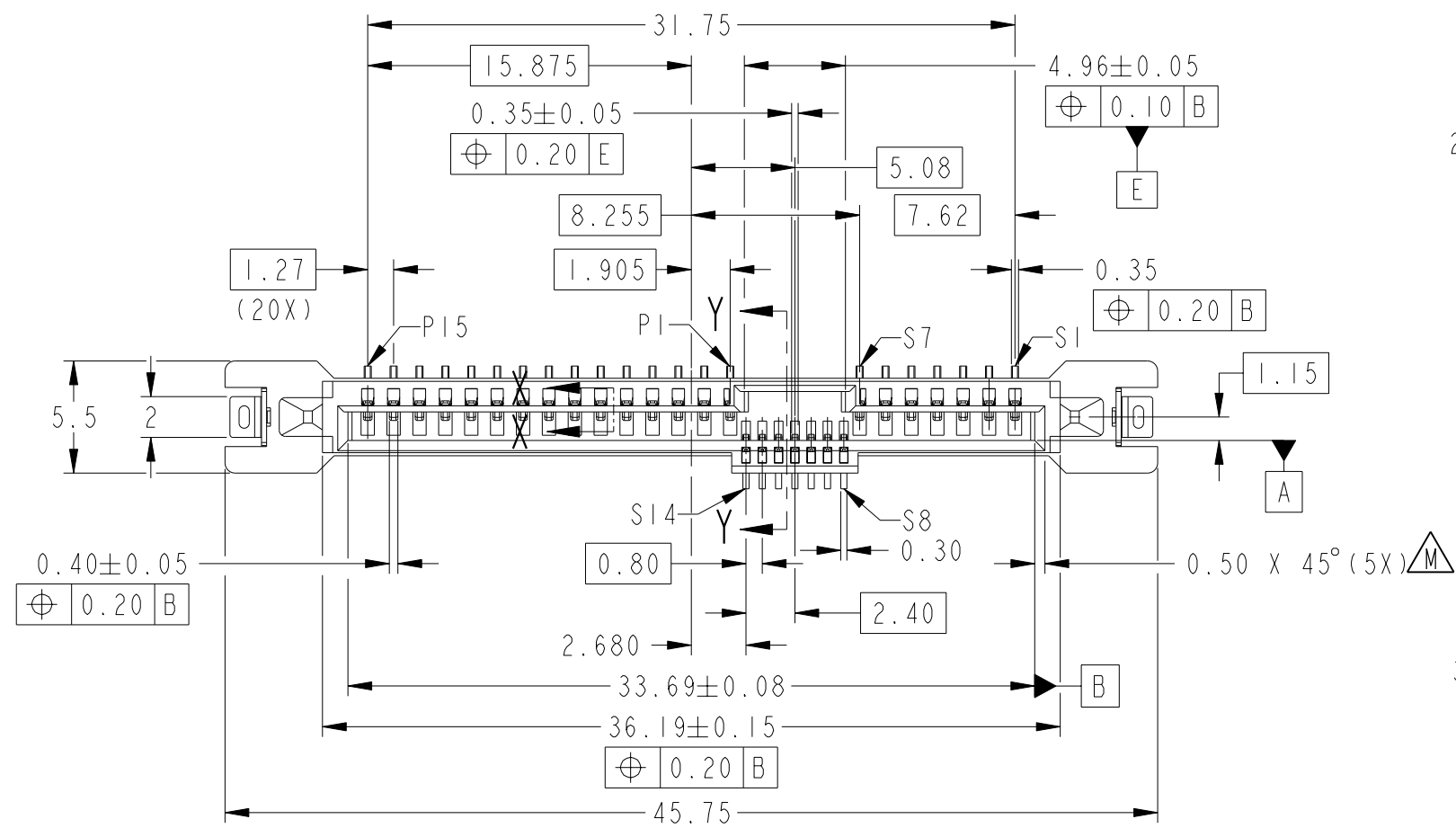

| | | | | | | | | | | | |
|---------------------------------------|--------------------------------|-------------|---------|------------|----------------|-----|------------------------|----------|--------------|-----|---|
| spec ref | - | dr | GL LOO | 2004-02-27 | projection | MM | size | A3 | scale | 3:1 | |
| tolerance std | ISO 406 ISO 1101 | eng | GL LOO | 2004-02-27 | | | ecn no | S10-0228 | | | |
| TOLERANCES UNLESS OTHERWISE SPECIFIED | | chr | GL LOO | 2010-10-28 | | | rel level | - | | | |
| surface | ISO 1302 | appr | JOEY NG | 2010-10-28 | product family | SAS | | | rel level | - | |
| linear | 0.X ± 0.XX ±0.20 0.XXX ± | | | title | SAS RECEPTACLE | | dwg no | 10031567 | | rev | M |
| angular | 0° ±2° | www.fci.com | | cat. no. | - | | Product - Customer Drw | | sheet 1 of 3 | | |

Copyright FCI.

| PRODUCT NO | METAL CLIP | PLATING | PICK-UP CAP | PACKAGING | REMARKS | PRODUCT NO | PLATING |
|--------------------|------------|---------|-------------|-------------|--------------|--------------------|---------|
| 10031567-002LF | 1 PC | NOTE 2 | NO | TRAY | NOTE ⑧ | 10031567-402LF | NOTE ⑪ |
| 10031567-002CLF | | | YES | | NOTE ④ & ⑧ | 10031567-402CLF | |
| 10031567-002C-TRLF | | | YES | TAPE & REEL | NOTE ④ ⑥ & ⑧ | 10031567-402C-TRLF | |

NOTE 11

| PRODUCT NO | METAL CLIP | PLATING | PICK-UP CAP | PACKAGING | REMARKS |
|--------------------|------------|---------|-------------|-------------------------|--------------|
| 10031567-404C-TRLF | 1 PC | NOTE 11 | YES | CUSTOM-MADE TAPE & REEL | NOTE ④ ⑥ & ⑧ |

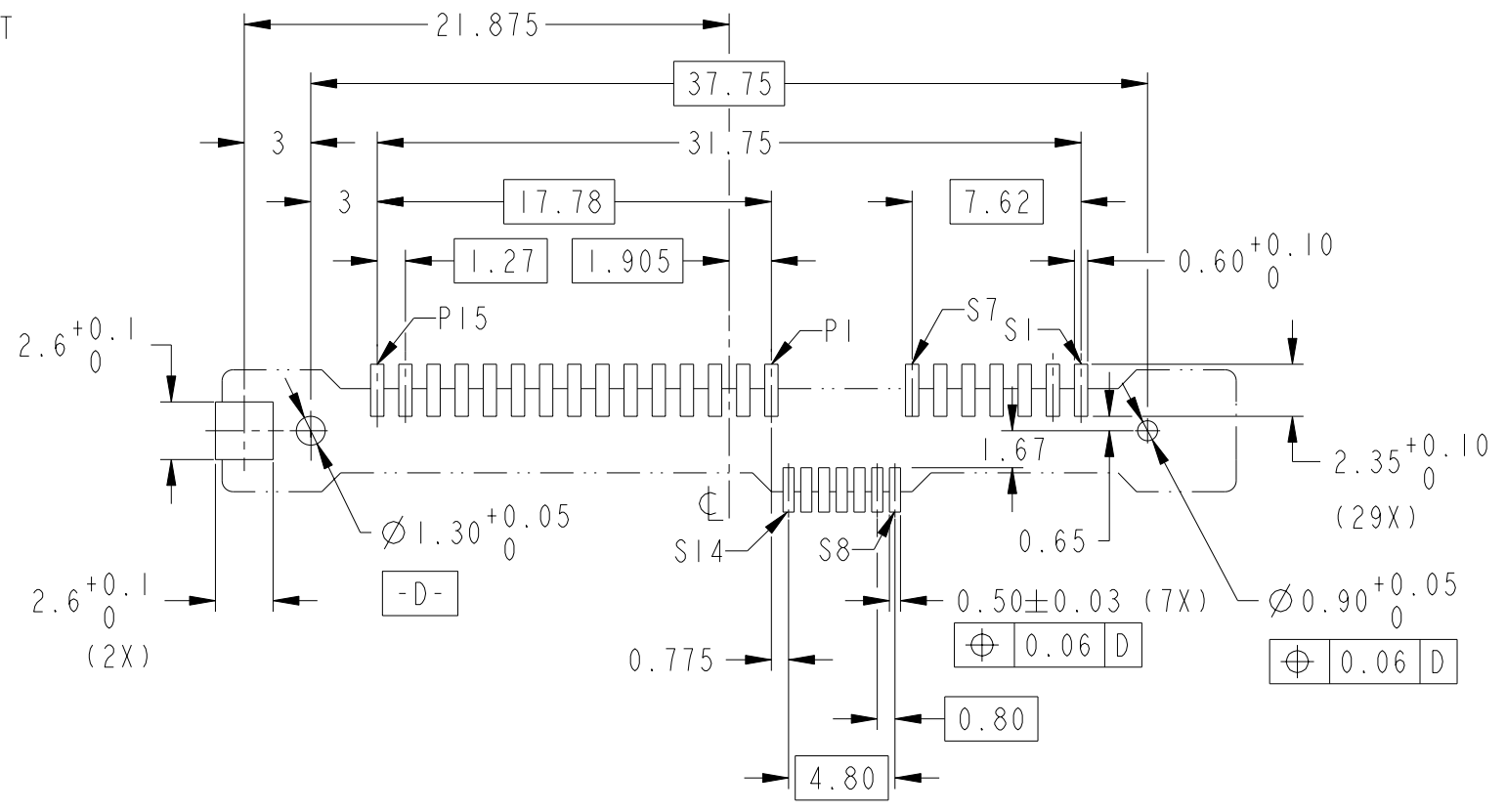
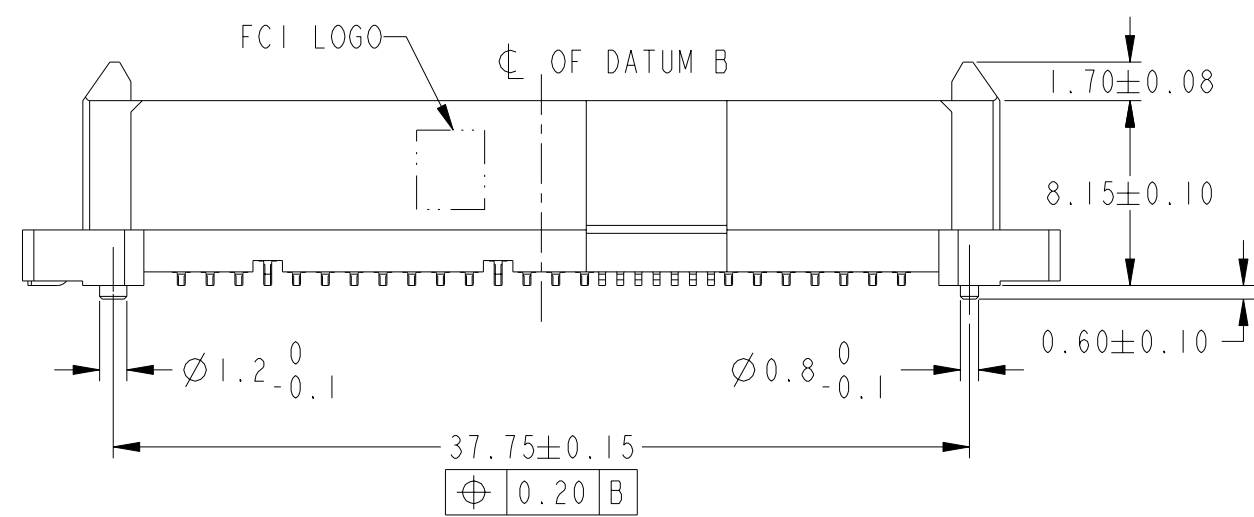
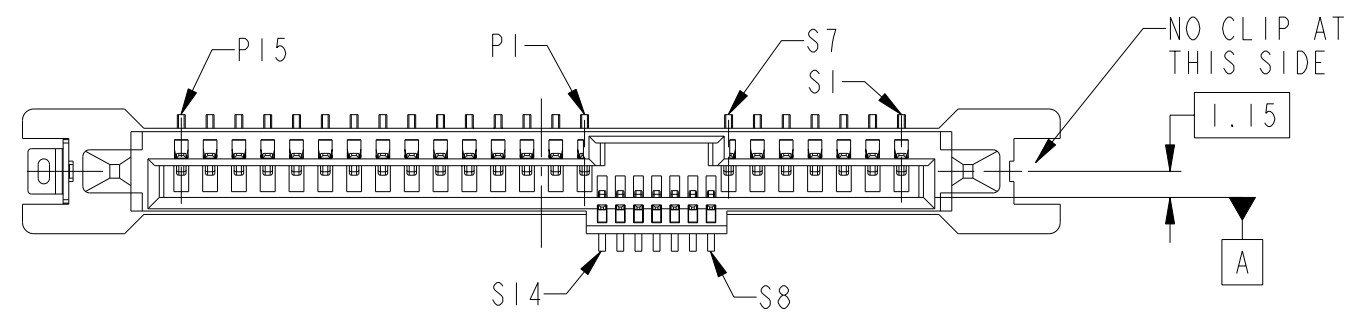

RECOMMENDED PCB LAYOUT

ALL OTHER DIMENSIONS, REFER TO SHEET 1.



Copyright FCI.

| | | | | | | | | | | |
|---------------------------------------|------------------------------------|-------------|---------|------------|------------|------------------------|--------------|----------|-----------|-----|
| spec ref | - | dr | GL LOO | 2004-02-27 | projection | MM | size | A3 | scale | 3:1 |
| tolerance std | ISO 406 ISO 1101 | eng | GL LOO | 2004-02-27 | | | ecn no | S10-0228 | rel level | - |
| TOLERANCES UNLESS OTHERWISE SPECIFIED | | chr | GL LOO | 2010-10-28 | | | | | | |
| surface | ISO 1302 | appr | JOEY NG | 2010-10-28 | | | rev | 10031567 | M | |
| linear | 0.X ± - 0.XX ±0.20 0.XXX ± - | www.fci.com | | cat. no. | - | Product - Customer Drw | sheet 3 of 3 | | | |
| angular | 0° ±2° | | | | | | | | | |