

W4E450-CO15-66

AC axial fan

sickled blades (S series), single inlet

Wall ring with guard grille

ebm-papst Mulfingen GmbH & Co. KG

Bachmühle 2 · D-74673 Mulfingen

Phone +49 7938 81-0

Fax +49 7938 81-110

info1@de.ebmpapst.com

www.ebmpapst.com

Limited partnership · Headquarters Mulfingen
County court Stuttgart · HRA 590344

General partner Elektrobau Mulfingen GmbH · Headquarters Mulfingen
County court Stuttgart · HRB 590142

Nominal data

Type	W4E450-CO15-66		
Motor	M4E094-HA		
Phase		1~	1~
Nominal voltage	VAC	115	115
Frequency	Hz	50	60
Type of data definition		ml	ml
Valid for approval / standard		CE	CE
Speed	min ⁻¹	1330	1410
Power input	W	470	640
Current draw	A	4.5	5.75
Motor capacitor	µF	40	40
Capacitor voltage	VDB	250	250
Capacitor standard		P0 (CE)	
Max. back pressure	Pa	110	130
Min. ambient temperature	°C	-40	-40
Max. ambient temperature	°C	65	60
Starting current	A	9.72	8.45
Maximum safe operating speed	min ⁻¹	1820 (55°C)	1820 (55°C)

ml = Max. load · me = Max. efficiency · fa = Running at free air · cs = Customer specs · cu = Customer unit
Subject to alterations



AC axial fan

sickled blades (S series), single inlet

Wall ring with guard grille

Technical features

Mass	12.9 kg
Size	450 mm
Surface of rotor	Coated in black
Material of terminal box	PC / ABS plastic
Material of blades	Press-fitted sheet steel blank, sprayed with PP plastic
Material of wall ring	Sheet steel, galvanised and coated in black plastic (RAL 9005)
Material of guard grille	Steel, coated in black plastic (RAL9005)
Number of blades	5
Direction of air flow	"V"
Direction of rotation	Counter-clockwise, seen on rotor
Type of protection	IP 54
Insulation class	"F"
Humidity class	F4-1
Max. permissible ambient motor temp. (transp./ storage)	+80 °C
Min. permissible ambient motor temp. (transp./storage)	-40 °C
Mounting position	Shaft horizontal or rotor on bottom; rotor on top on request
Condensate discharge holes	Rotor-side
Operation mode	S1
Motor bearing	Ball bearing
Touch current acc. IEC 60990 (measuring network Fig. 4, TN system)	<= 3.5 mA
Electrical leads	Via terminal box, integrated capacitor connected via terminal box
Motor protection	Thermal overload protector (TOP) brought out
Protection class	I (if protective earth is connected by customer)
Product conforming to standard	EN 60034-1 (2010); CE
Approval	UL 1004-1; CSA C22.2 Nr.100



AC axial fan

sickled blades (S series), single inlet

Wall ring with guard grille

Product drawing

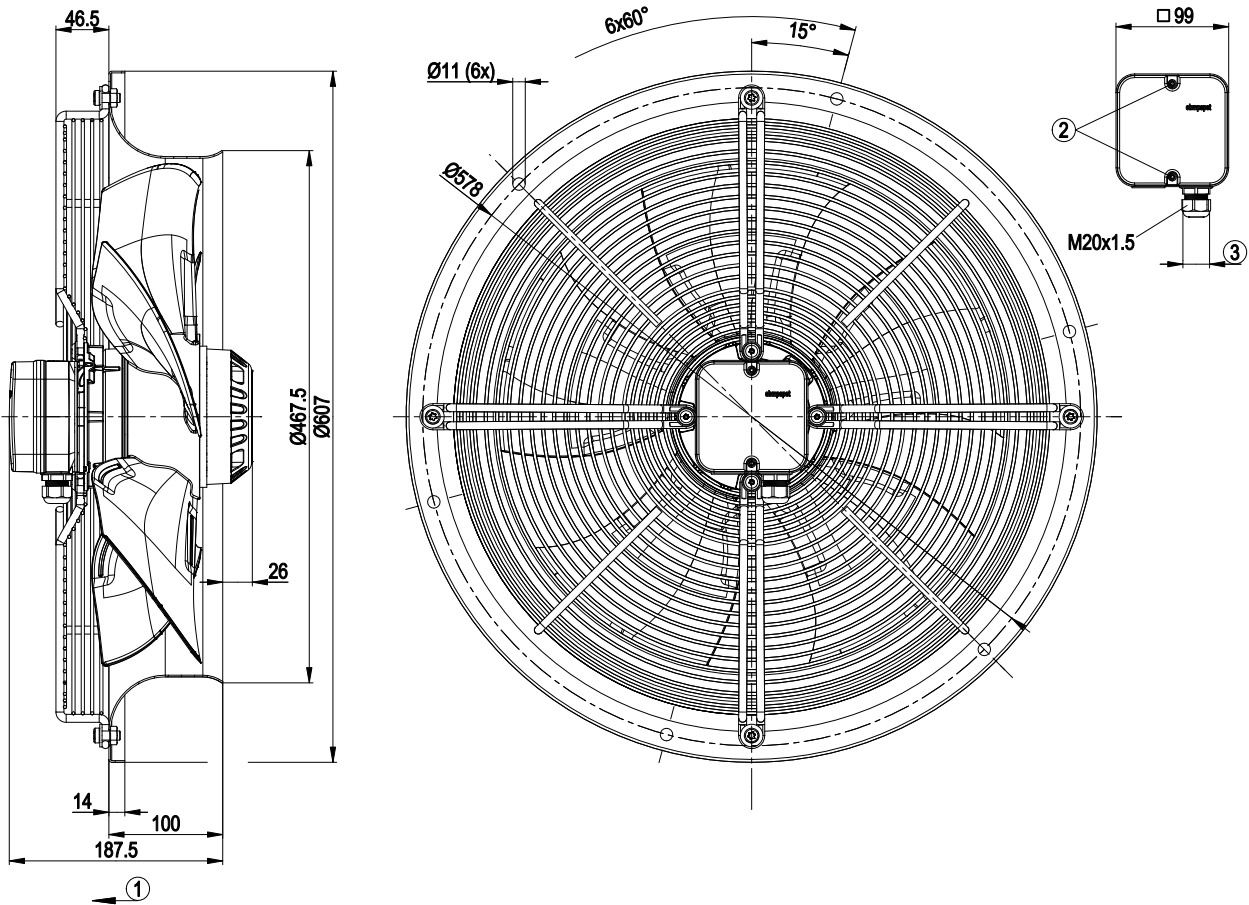

1	Direction of air flow "V"
2	Tightening torque 1.5 ± 0.2 Nm
3	Cable diameter: min. 6 mm, max. 12 mm; tightening torque 2 ± 0.15 Nm



AC axial fan

sickled blades (S series), single inlet

Wall ring with guard grille

Connection screen

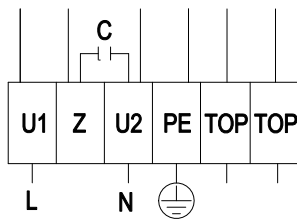

L	= U1 = blue	Z	brown	N	= U2 = black
PE	green / yellow	TOP	grey		

AC axial fan

sickled blades (S series), single inlet

Wall ring with guard grille

Charts: Air flow 50 Hz

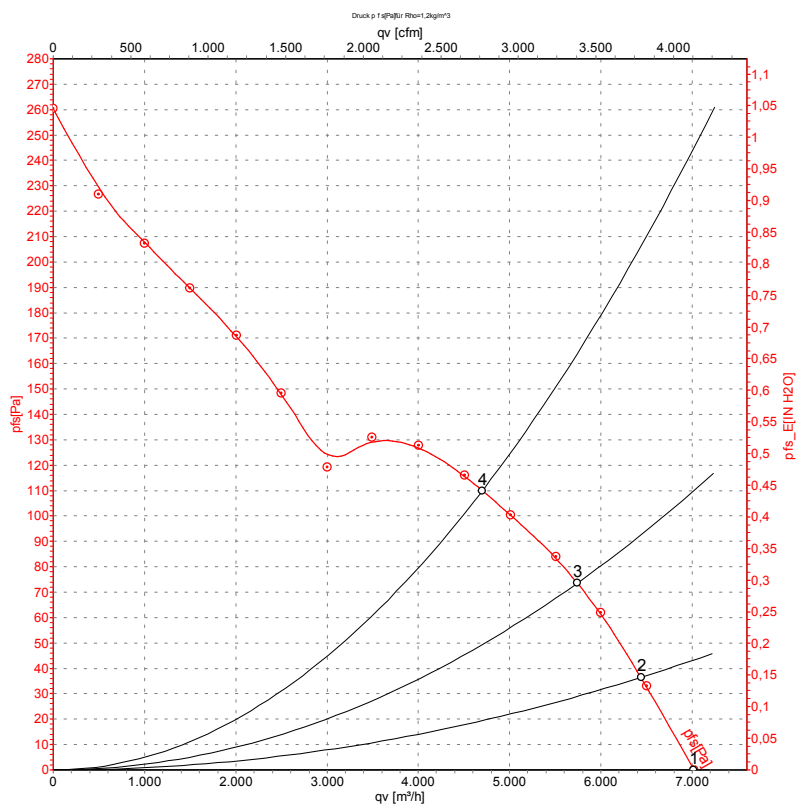

Measurement: LU-136744

Air performance measured as per ISO 5801 Installation category A. For detailed information on the measuring set-up, please contact ebm-papst. Suction-side noise levels: L_{wA} measured as per ISO 13347 / L_{pA} measured with 1m distance to fan axis. The values given are valid under the measuring conditions mentioned above and may vary according to the actual installation situation. With any deviation from the standard set-up, the specific values have to be checked and reviewed with the unit installed.

Measured values

	U	f	n	P _e	I	qv	p _{fs}
	V	Hz	min ⁻¹	W	A	m ³ /h	Pa
1	115	50	1375	392	3.93	7015	0
2	115	50	1360	418	4.13	6440	37
3	115	50	1350	439	4.30	5740	74
4	115	50	1330	470	4.50	4700	110

U = Supply voltage · f = Frequency · n = Speed · P_e = Power input · I = Current draw · qv = Air flow · p_{fs} = Pressure increase



AC axial fan

sickled blades (S series), single inlet

Wall ring with guard grille

Charts: Air flow 60 Hz

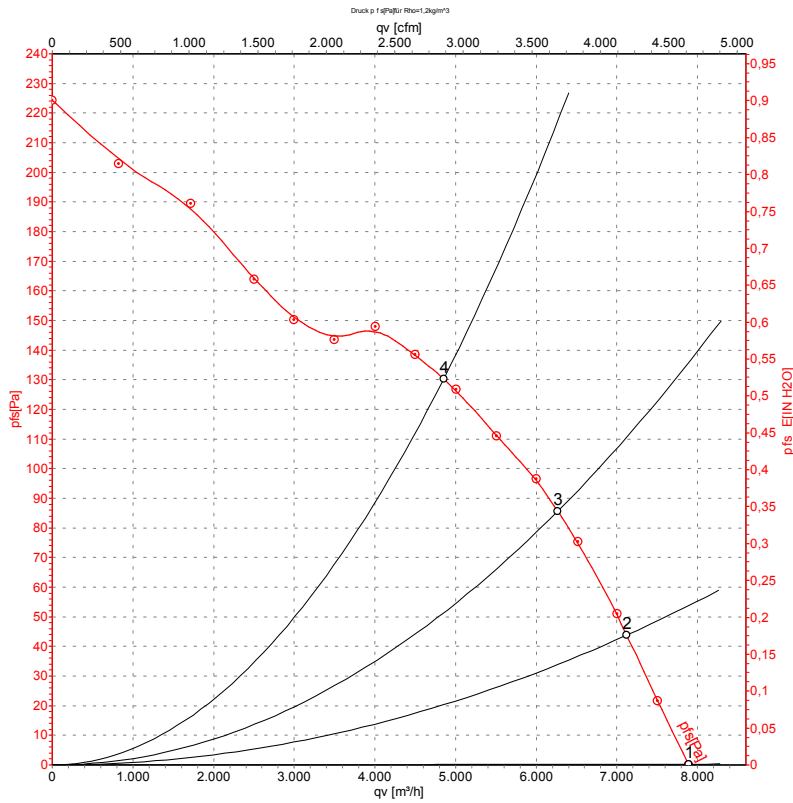

Measurement: LU-136748

Air performance measured as per ISO 5801 Installation category A. For detailed information on the measuring set-up, please contact ebm-papst. Suction-side noise levels: L_{wA} measured as per ISO 13347 / L_{pA} measured with 1m distance to fan axis. The values given are valid under the measuring conditions mentioned above and may vary according to the actual installation situation. With any deviation from the standard set-up, the specific values have to be checked and reviewed with the unit installed.

Measured values

	U	f	n	P _e	I	qv	p _{fs}
	V	Hz	min ⁻¹	W	A	m ³ /h	Pa
1	115	60	1540	560	5.00	7890	0
2	115	60	1500	586	5.21	7125	45
3	115	60	1465	609	5.45	6270	85
4	115	60	1410	640	5.75	4850	130

U = Supply voltage · f = Frequency · n = Speed · P_e = Power input · I = Current draw · qv = Air flow · p_{fs} = Pressure increase

