

D-SUB connector set - VS-15-SET-STD - 1689129

Please be informed that the data shown in this PDF Document is generated from our Online Catalog. Please find the complete data in the user's documentation. Our General Terms of Use for Downloads are valid (<http://phoenixcontact.com/download>)



D-SUB connector set, shell size 2, IP67 degree of protection

The figure shows the product version VS-09-SET-STD

Your advantages

- IP67 protection class
- Two cable outlets ideal for hybrid applications

Key Commercial Data

Packing unit	1 pc
GTIN	 4 017918 877989
GTIN	4017918877989
Weight per Piece (excluding packing)	60.500 g
Custom tariff number	85366990
Country of origin	Germany

Technical data

Mechanical characteristics

Number of positions	15
Shielded	no
External cable diameter	3 mm ... 9 mm
Cable outlet	Angled
Color	gray
Degree of protection	IP67
Type	D-SUB 15
Size of housing	2
No. of cable outlets	2

D-SUB connector set - VS-15-SET-STD - 1689129

Technical data

Ambient conditions

Ambient temperature (operation)	-40 °C ... 80 °C
---------------------------------	------------------

Material data

Flammability rating according to UL 94	V0
Housing material	PA
Sealing material	Flat gasket: NBR; profile gasket: EPDM
Seal material	Flat gasket: NBR; profile gasket: EPDM
Cable seal material	CR/NBR

Electrical characteristics

Number of positions	15
Degree of pollution	2

Standards and Regulations

Flammability rating according to UL 94	V0
--	----

Environmental Product Compliance

China RoHS	Environmentally friendly use period: unlimited = EFUP-e
	No hazardous substances above threshold values

Drawings

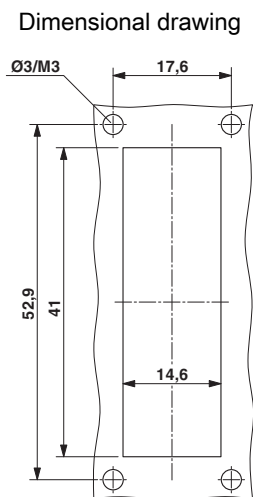

Mounting cutout

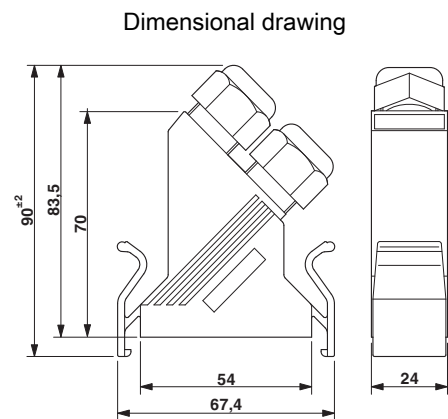

D-SUB sleeve housings

D-SUB connector set - VS-15-SET-STD - 1689129

Dimensional drawing

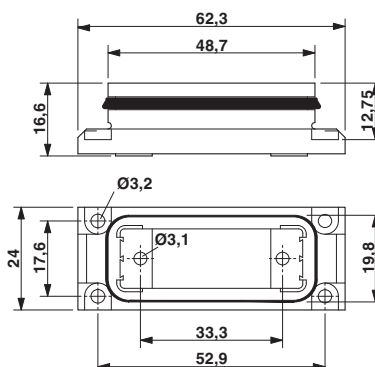

D-SUB panel mounting frame

Classifications

eCl@ss

eCl@ss 4.0	27140816
eCl@ss 4.1	27260701
eCl@ss 5.0	27260701
eCl@ss 5.1	27261200
eCl@ss 6.0	27261200
eCl@ss 7.0	27440302
eCl@ss 8.0	27440302
eCl@ss 9.0	27440302

ETIM

ETIM 2.0	EC000437
ETIM 3.0	EC000437
ETIM 4.0	EC001132
ETIM 5.0	EC001132
ETIM 6.0	EC001132

UNSPSC

UNSPSC 6.01	31261501
UNSPSC 7.0901	31261501
UNSPSC 11	31261501
UNSPSC 12.01	31261501
UNSPSC 13.2	39121522

Approvals

Approvals

D-SUB connector set - VS-15-SET-STD - 1689129

Approvals

Approvals

EAC

Ex Approvals

Approval details

EAC		B.01742
-----	---	---------

Accessories

Accessories

Female insert

D-SUB contact insert - VS-15-BU-DSUB/16-MPT-0,5 - 1688094



D-SUB contact insert, shell size 2, with 15 signal contacts, female type of contact, screw connection, straight, for panel mounting frame and sleeve housing with IP67 protection

Male insert

D-SUB contact insert - VS-15-ST-DSUB/16-MPT-0,5 - 1688078



D-SUB contact insert, shell size 2, with 15 signal contacts, male type of contact, screw connection, straight, for panel mounting frame and sleeve housing with IP67 protection
