

THIS DRAWING IS UNPUBLISHED. RELEASED FOR PUBLICATION
 © COPYRIGHT BY TYCO ELECTRONICS CORPORATION. ALL RIGHTS RESERVED.

LOC	DIST	REVISIONS				
P	LTR	DESCRIPTION	DATE	DWN	APVD	
DW		B3	REVISED (ECR-09-010589)	28APR09	SC	WK

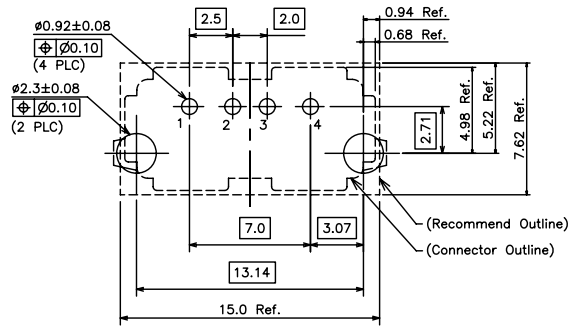

RECOMMENDED P.C.BOARD LAYOUT(T=1.6)
 (TOP VIEW)(TOLERANCE:±0.05)

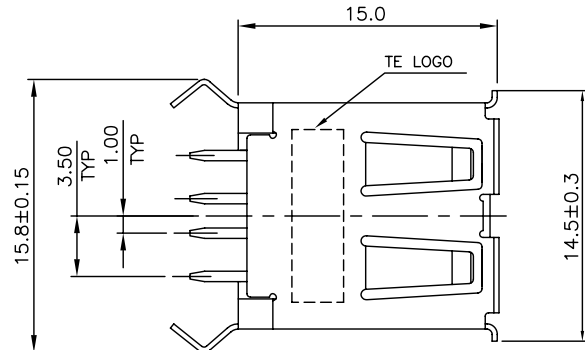
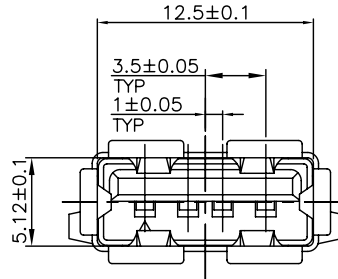
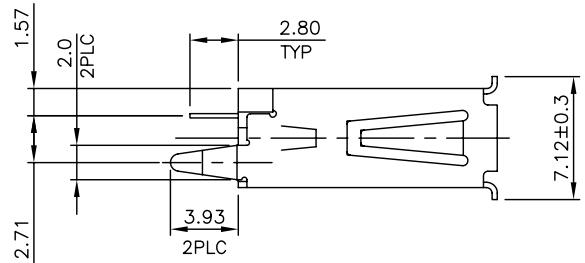

- NOTE:
- MATERIAL:
 HOUSING: THERMOPLASTIC(PBT), UL 94V-0, COLOR:SEE TABLE.
 CONTACTS: PHOSPHOR BRONZE. THICKNESS=0.25
 SHELL: BRASS. THICKNESS=0.30
 - FINISH:
 CONTACTS: 0.76µm [30µ"] MIN. GOLD PLATED ON CONTACT AREA,
 2.54µm [100µ"] MIN. TIN-Cu ON SOLDER TAILS,
 1.27µm [50µ"] MIN. NICKEL. UNDERPLATED ALL OVER
 SHELL: 2.54µm [100µ"] MIN. TIN PLATED OVER
 1.27µm [50µ"] MIN. NICKEL UNDERPLATED
 - WAVE SOLDER CAPABLE TO 265°C PER TEST SPEC.
 109-202, CONDITION B.
 - HOUSING MIGHT BE MELTED AFTER DIFFERENT CUSTOMER WAVE SOLDERING PROCESS.

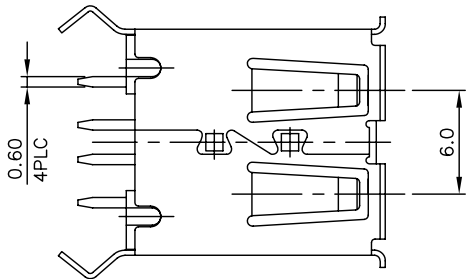

SEE SHEET 3	BLACK	1734366-4
	BLUE	1734366-3
SEE SHEET 2	WHITE	1734366-2
	BLACK	1734366-1
PACKING	HSG'S COLOR	PART NUMBER

THIS DRAWING IS A CONTROLLED DOCUMENT.		DWN S. CHIEN 19SEP2008	Tyco Electronics Corporation Tapei, Taiwan	
DIMENSIONS: MM		CHK S. CHIEN 19SEP2008	NAME	
TOLERANCES UNLESS OTHERWISE SPECIFIED: 0 PLC ± 0.38 1 PLC ± 0.25 2 PLC ± 0.13 3 PLC ± 0.05		APVD W. KODAMA 19SEP2008	RECEIPT ASSY, VERTICAL, 4POSITION THRU-HOLE, TYPE A USB	
MATERIAL SEE NOTE		PRODUCT SPEC 108-57547	QUALIFICATION TEST REPORT 501-57635	RESTRICTED TO
ANGLES ± 2° FINISH SEE NOTE		WEIGHT 1.82GRAMS	SIZE A3	CAGE CODE 00779
		CUSTOMER DRAWING	DRAWING NO G=1734366	SCALE 1 OF 3
			SHEET	REV B3

THIS DRAWING IS UNPUBLISHED. RELEASED FOR PUBLICATION
 © COPYRIGHT BY TYCO ELECTRONICS CORPORATION. ALL RIGHTS RESERVED.

LOC	DIST	REVISIONS			
P	LTR	DESCRIPTION	DATE	DWN	APVD
DW		SEE SHEET 1.			

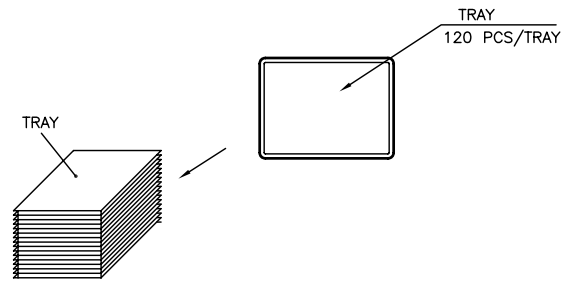

USE THE TAPE TO FIX THE TRAY(4X)

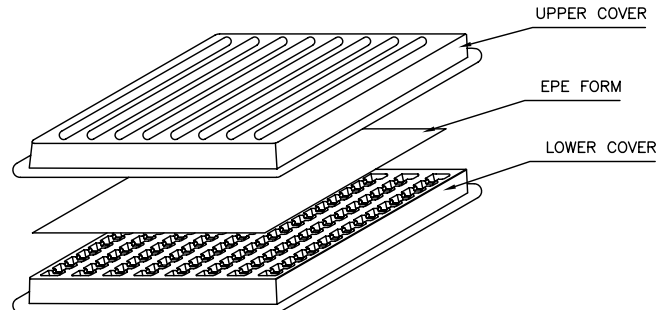
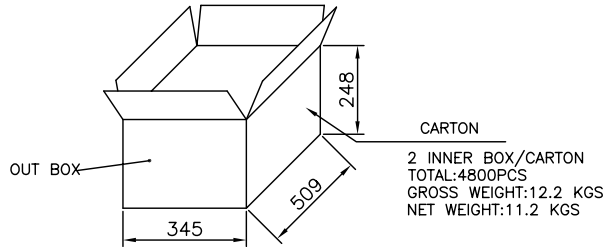
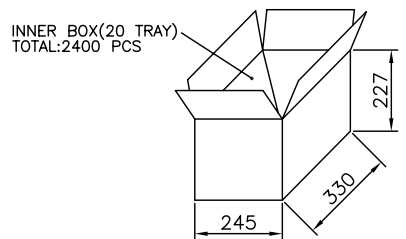
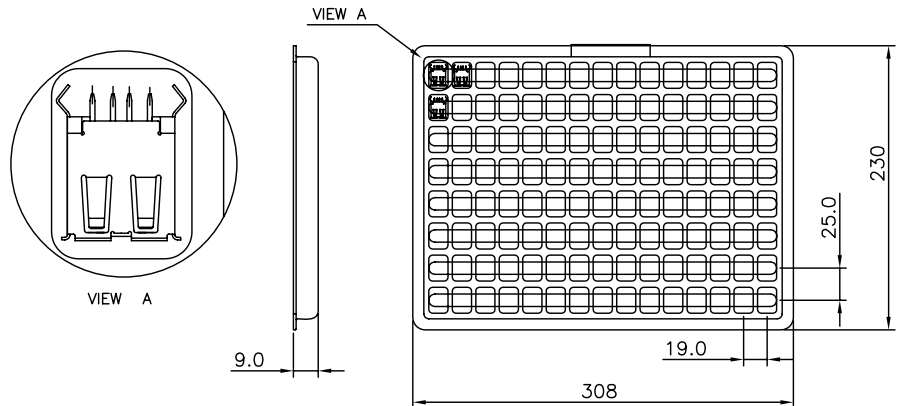

NOTE:
 1. PACKAGING MATERIAL IN PLASTIC, RUBBER, INK, PIGMENT AND PAINT MUST MEET CONTROLLED SUBSTANCES SPEC PER 230-702.
 * CADMIUM AND CADMIUM COMPOUNDS NOT TO EXCEED: 5 PPM.
 * LEAD, CADMIUM, CHROM VI AND MERCURY NOT TO EXCEED: 100 PPM (COMBINED).
 2. MATERIAL:
 TRAY: PVC, UPPER COVER THICKNE=0.3MM. LOWER COVER THICKNE=0.4MM

4800	1734366-2
4800	1734366-1
QTY	PART NUMBER

THIS DRAWING IS A CONTROLLED DOCUMENT.		DWN		Tyco Electronics Corporation Taipei, Taiwan	
DIMENSIONS: MM		CHK		NAME	
TOLERANCES UNLESS OTHERWISE SPECIFIED:		APVD		RECEIPT ASSY, VERTICAL, 4POSITION THRU-HOLE, TYPE A USB	
0 PLC ± -		PRODUCT SPEC		SIZE CAGE CODE DRAWING NO	
1 PLC ± -		APPLICATION SPEC		A3 00779 C=1734366	
2 PLC ± -		WEIGHT		RESTRICTED TO	
3 PLC ± -		CUSTOMER DRAWING		SCALE SHEET 2 OF 3 REV B3	
4 PLC ANGLES ± -		FINISH			
MATERIAL					

THIS DRAWING IS UNPUBLISHED. RELEASED FOR PUBLICATION
 © COPYRIGHT BY TYCO ELECTRONICS CORPORATION. ALL RIGHTS RESERVED.

LOC	DIST	REVISIONS			
P	LTR	DESCRIPTION	DATE	DWN	APVD
DW		SEE SHEET 1.			

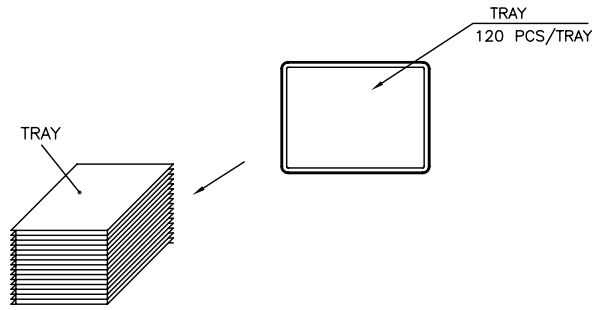

USE THE TAPE TO FIX THE TRAY(4X)

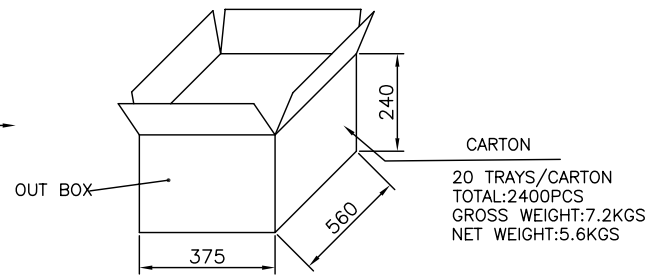
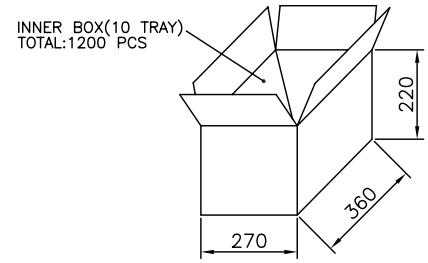
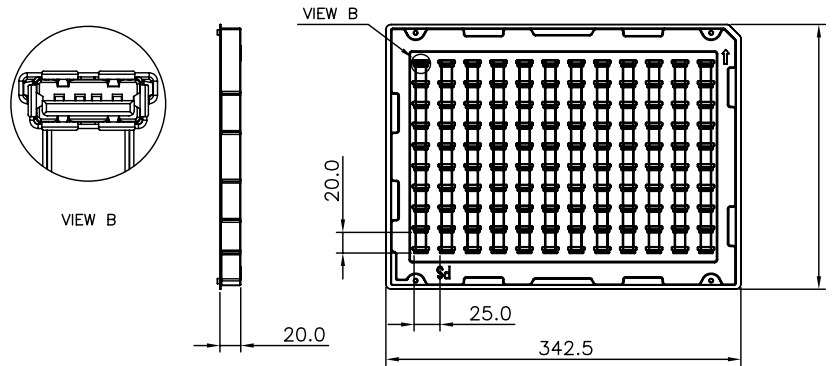

CARTON
 20 TRAYS/CARTON
 TOTAL:2400PCS
 GROSS WEIGHT:7.2KGS
 NET WEIGHT:5.6KGS

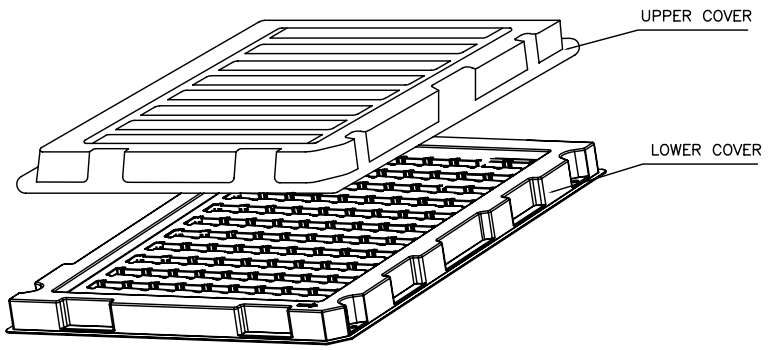

NOTE:
 1. PACKAGING MATERIAL IN PLASTIC, RUBBER, INK, PIGMENT AND PAINT MUST MEET CONTROLLED SUBSTANCES SPEC PER 230-702.
 * CADMIUM AND CADMIUM COMPOUNDS NOT TO EXCEED: 5 PPM.
 * LEAD, CADMIUM, CHROM VI AND MERCURY NOT TO EXCEED: 100 PPM (COMBINED).
 2. MATERIAL:
 TRAY: PS, UPPER COVER THICKNE=0.5MM. LOWER COVER THICKNE=0.7MM

2400	1734366-4
2400	1734366-3
QTY	PART NUMBER

THIS DRAWING IS A CONTROLLED DOCUMENT.		DWN		Tyco Electronics Corporation Taipei, Taiwan	
DIMENSIONS: MM		CHK		NAME	
TOLERANCES UNLESS OTHERWISE SPECIFIED:		APVD		RECEPT ASSY, VERTICAL, 4POSITION THRU-HOLE, TYPE A USB	
0 PLC ± -		PRODUCT SPEC		SIZE CAGE CODE DRAWING NO	
1 PLC ± -		APPLICATION SPEC		A3 00779 C=1734366	
2 PLC ± -		WEIGHT		RESTRICTED TO	
3 PLC ± -		CUSTOMER DRAWING		SCALE SHEET 3 OF 3 REV B3	
4 PLC ± -					
ANGLES ± -					
FINISH					