

# **Hardware Manual**

## **5000-235-001**

### **STR2M**

## **Step Motor Drive**

920-0067A  
1/10/2013



## Contents

|  |    |
|--|----|
| Safety Instructions .....                      | 3  |
| Introduction .....                             | 5  |
| Features .....                                 | 5  |
| Block Diagram .....                            | 6  |
| Getting Started.....                           | 7  |
| Mounting the Drive .....                       | 8  |
| Connecting the Power Supply .....              | 8  |
| Choosing a Power Supply.....                   | 10 |
| Voltage .....                                  | 10 |
| Current .....                                  | 10 |
| Multiple Drives Sharing One Power Supply ..... | 11 |
| System Wiring Recommendations .....            | 12 |
| Connecting the Motor.....                      | 13 |
| Four Lead Motor .....                          | 13 |
| Eight Lead Motor .....                         | 13 |
| Connecting Input Signals.....                  | 14 |
| Connection Examples: STEP & DIR .....          | 14 |
| Connector Pin Diagram.....                     | 14 |
| Internal Circuit Diagram .....                 | 14 |
| Connection Examples: EN.....                   | 15 |
| FAULT Output.....                              | 16 |
| Configuring the Drive.....                     | 17 |
| Step 1: Setting the Current .....              | 17 |
| Step 2: Setting Idle Current .....             | 18 |
| Step 4: Step Size.....                         | 19 |
| Step 5: Step Pulse Type.....                   | 21 |
| Step 6: Step Pulse Noise Filter.....           | 21 |
| Self Test.....                                 | 22 |
| Drive Heating.....                             | 23 |
| Mechanical Outline .....                       | 24 |
| Technical Specifications .....                 | 25 |
| Mating Connectors and Accessories.....         | 26 |
| Alarm Codes .....                              | 27 |
| Connector Diagrams.....                        | 27 |

## Safety Instructions

Only qualified personnel are permitted to transport, assemble, commission, and maintain this equipment. Properly qualified personnel are persons who are familiar with the transport, assembly, installation, commissioning and operation of motors, and who have the appropriate qualifications for their jobs. The qualified personnel must know and observe the following standards and regulations:

IEC 364 resp. CENELEC HD 384 or DIN VDE 0100

IEC report 664 or DIN VDE 0110

National regulations for safety and accident prevention or VBG 4

To minimize the risk of potential safety problems, you should follow all applicable local and national codes that regulate the installation and operation of your equipment. These codes vary from area to area and it is your responsibility to determine which codes should be followed, and to verify that the equipment, installation, and operation are in compliance with the latest revision of these codes.

Equipment damage or serious injury to personnel can result from the failure to follow all applicable codes and standards. We do not guarantee the products described in this publication are suitable for your particular application, nor do we assume any responsibility for your product design, installation, or operation.

- Read all available documentation before assembly and commissioning. Incorrect handling of products in this manual can result in injury and damage to persons and machinery. Strictly adhere to the technical information on the installation requirements.
- It is vital to ensure that all system components are connected to earth ground. Electrical safety is impossible without a low-resistance earth connection.
- The STR2M contains electrostatically sensitive components that can be damaged by incorrect handling. Discharge yourself before touching the product. Avoid contact with high insulating materials (artificial fabrics, plastic film, etc.). Place the product on a conductive surface.
- During operation keep all covers and cabinet doors shut. Otherwise, there are deadly hazards that could possibly cause severe damage to health or the product.

- In operation, depending on the degree of enclosure protection, the product can have bare components that are live or have hot surfaces. Control and power cables can carry a high voltage even when the motor is not rotating.
- Never pull out or plug in the product while the system is live. There is a danger of electric arcing and danger to persons and contacts.
- After powering down the product, wait at least ten minutes before touching live sections of the equipment or undoing connections (e.g., contacts, screwed connections). Capacitors can store dangerous voltages for long periods of time after power has been switched off. To be safe, measure the contact points with a meter before touching.

Be alert to the potential for personal injury. Follow the recommended precautions and safe operating practices. Safety notices in this manual provide important information. Read and be familiar with these instructions before attempting installation, operation, or maintenance. The purpose of this section is to alert users to possible safety hazards associated with this equipment and the precautions that need to be taken to reduce the risk of personal injury and damage to the equipment. Failure to observe these precautions could result in serious bodily injury, damage to the equipment, or operational difficulty.

## Introduction

Thank you for selecting an Applied Motion Products motor control. We hope our dedication to performance, quality and economy will make your motion control project successful.

If there's anything we can do to improve our products or help you use them better, please call or fax. We'd like to hear from you. Our phone number is (800) 525-1609, or you can reach us by fax at (831) 761-6544. You can also email [support@applied-motion.com](mailto:support@applied-motion.com).

## Features

- Low cost, digital step motor driver in compact package
- Operates from a 12 to 48 volt DC power supply
- Running current up to 2.2 amps per phase
- Operates from Step & Direction signals or Step CW & Step CCW (jumper selectable)
- Enable input
- Fault output
- Optically isolated I/O
- Digital filters prevent position error from electrical noise on command signals
  - switch selectable: 150 kHz or 2 MHz
- Electronic damping and anti-resonance
- Automatic idle current reduction to reduce heat when motor is not moving
  - Switch selectable: 50% or 90% of running current
- 16 switch selectable resolutions, 200 to 25600 steps/rev
- Switch selectable microstep emulation provides smoother, more reliable motion
- Self test (switch selectable)

### Block Diagram

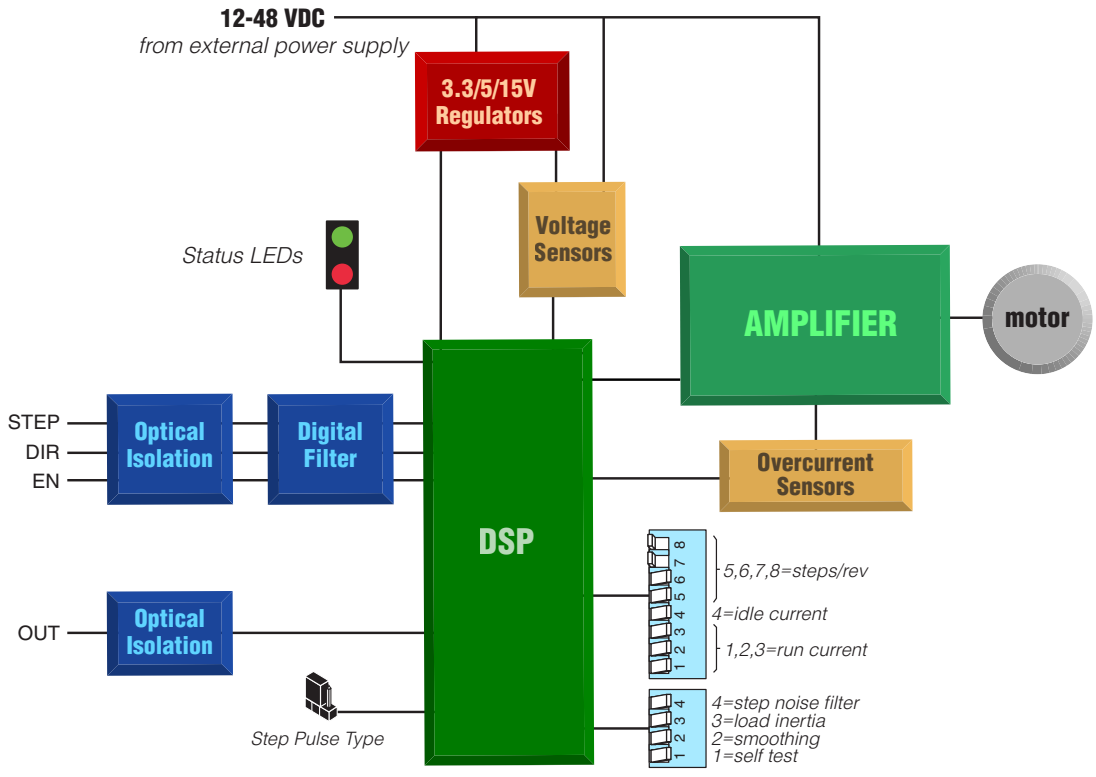

## Getting Started

To use your STR2M step motor drive, you'll need the following:

- a 12 to 48 volt DC power supply. Please read the section *Choosing a Power Supply* for help in choosing the right power supply.
- one of the motors listed recommended in this manual.
- a small flat blade screwdriver for tightening the connectors.
- a source of step signals, such as a PLC or motion controller.

The connectors and other points of interest are illustrated below. These are detailed later in the manual.

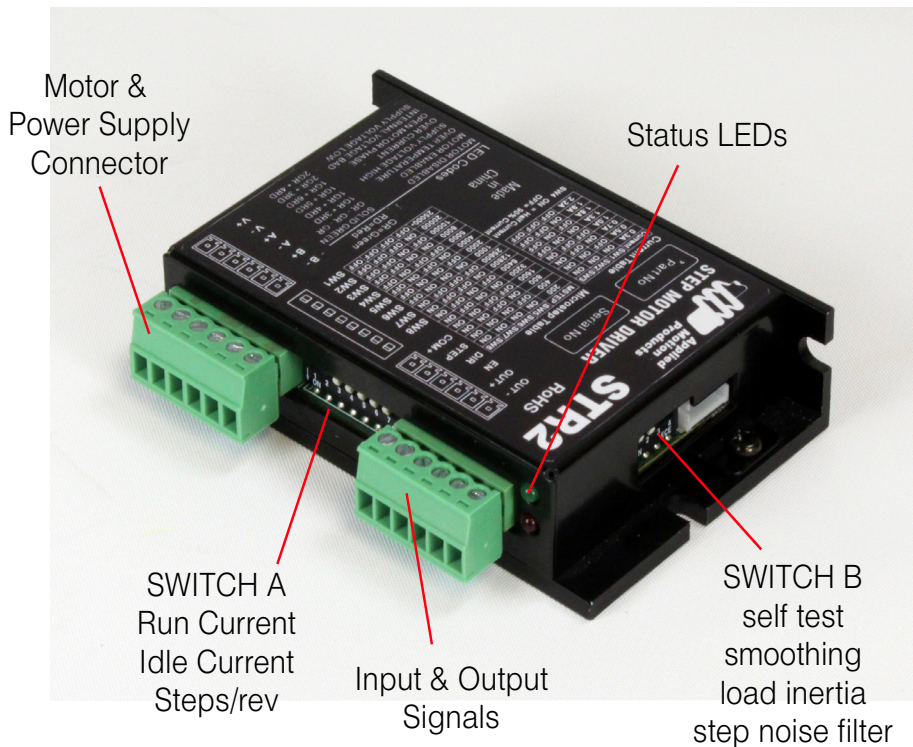

## Mounting the Drive

You can mount your drive on the wide or the narrow side of the chassis using #6 screws. If possible, the drive should be securely fastened to a smooth, flat metal surface that will help conduct heat away from the chassis. If this is not possible, then forced airflow from a fan may be required to prevent the drive from overheating. See "Drive Heating" for more details.

- ***Never use your drive in a space where there is no air flow or where other devices cause the surrounding air to be more than 50°C.***
- ***Never put the drive where it can get wet or where metal or other electrically conductive particles can get on the circuitry.***
- ***Always provide air flow around the drive. When mounting multiple drives near each other, maintain at least one half inch of space between drives.***

## Connecting the Power Supply

If you need information about choosing a power supply, please read the section *Choosing a Power Supply*.

- Connect the power supply "+" terminal to the connector terminal labeled "V+".
- Connect power supply "-" to the connector terminal labeled "V-".
- The green ground screw on the corner of the chassis should be connected to earth ground.
- Use 18 or 20 gauge wire.

The STR2M drive contains an internal fuse that connects to the power supply + terminal. This fuse is not user replaceable. If you want to install a user serviceable fuse in your system install a fast acting 3 amp fuse in line with the + power supply lead.



***Be careful not to reverse the wires. Reverse connection will destroy your drive, void your warranty and generally wreck your day.***

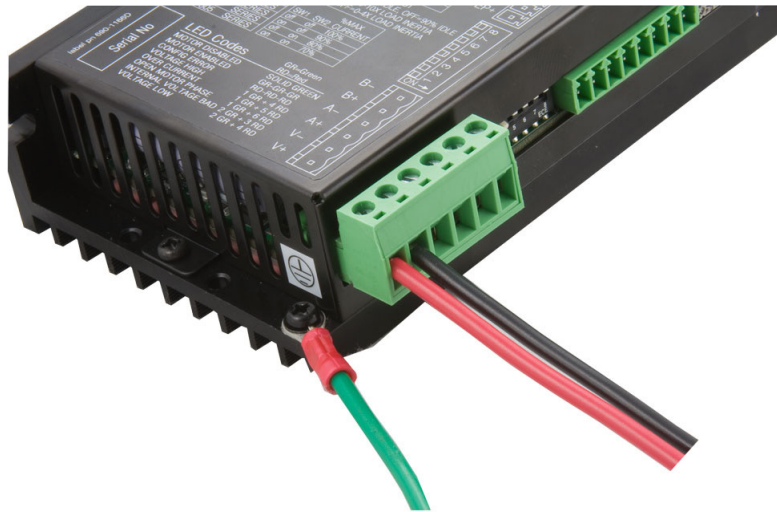

### Power Supply and Ground Connections

*Locate fuse in-line with "+" connection*

If you plan to use a regulated power supply you may encounter a problem with regeneration. If you rapidly decelerate a load from a high speed, much of the kinetic energy of that load is transferred back to the power supply. This can trip the overvoltage protection of a switching power supply, causing it to shut down. We offer the RC-050 "regeneration clamp" to solve this problem. If in doubt, buy an RC-050 for your first installation. If the "regen" LED on the RC-050 never flashes, you don't need the clamp.

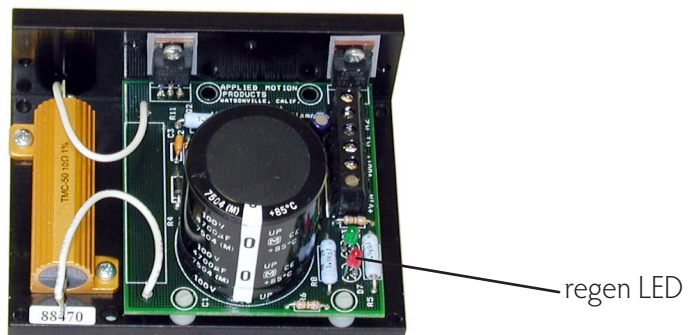

**RC-050 Regen Clamp**

## Choosing a Power Supply

When choosing a power supply, there are many things to consider. If you are manufacturing equipment that will be sold to others, you probably want a supply with all the safety agency approvals. If size and weight are an issue get a switching supply.

And you must decide what size of power supply (in terms of voltage and current) is needed for your application.

Applied Motion offers three power supplies that are excellent matches for the STR2M drive: PS50A24 (24V, 2.1A), PS150A24 (24V, 6.3A) and PS320A48 (48V, 6.7A).

## Voltage

Your motor can provide more torque at higher speeds if a higher power supply voltage is used. Please consult the speed-torque curves later in this manual for guidance.

If you choose an unregulated power supply, make sure the no load voltage of the supply does not exceed the drive's maximum input voltage specification.

## Current

The maximum supply current you could ever need is two times the motor current. However, you will generally need a lot less than that, depending on the motor type, voltage, speed and load conditions. That's because the STR2M uses a switching amplifier, converting a high voltage and low current into lower voltage and higher current. The more the power supply voltage exceeds the motor voltage, the less current you'll need from the power supply. A motor running from a 48 volt supply can be expected to draw only half the supply current that it would with a 24 volt supply.

We recommend the following selection procedure:

1. If you plan to use only a few drives, get a power supply with at least twice "per phase" current rating of the step motor. Example: for a motor that's rated for 2 A/phase use a 4 A power supply.
2. If you are designing for mass production and must minimize cost, get one power supply with more than twice the rated current of the motor. Install the motor in the application and monitor the current coming out of the power supply and into the drive at various motor loads. This will tell you how much current you really need so you can design in a lower cost

power supply.

The tables below and on the net page list the maximum current required for each motor at several common power supply voltages. Please consider this information when choosing a power supply.

**Table 1: STR2M Power Supply Current**

All motors connected as indicated.

| Motor          | Connection | Max Power Supply Current (A) |       |       |
|----------------|------------|------------------------------|-------|-------|
|                |            | 12VDC                        | 24VDC | 48VDC |
| NEMA8, 30mm    | 4 leads    | 0.95A                        | 0.95A | N/A   |
| NEMA8, 46mm    | 4 leads    | 0.95A                        | 0.95A | N/A   |
| NEMA11, 33.5mm | 4 leads    | 0.6A                         | 0.6A  | N/A   |
| NEMA11, 47.5mm | 4 leads    | 0.95A                        | 0.95A | N/A   |
| NEMA14, 40mm   | 4 leads    | 0.87A                        | 0.87A | N/A   |
| NEMA17, 33mm   | parallel   | 1.0A                         | 1.0A  | 1.0A  |
| NEMA17, 40mm   | parallel   | 1.3A                         | 1.3A  | 1.3A  |
| NEMA17, 48mm   | parallel   | 1.32A                        | 1.32A | 1.32A |
| NEMA23, 41mm   | series     | 1.36A                        | 1.36A | 1.36A |
| NEMA23, 54mm   | series     | 1.56A                        | 1.56A | 1.56A |
| NEMA23, 76mm   | series     | 1.4A                         | 1.4A  | 1.4A  |

### Multiple Drives Sharing One Power Supply

You can use one supply to power multiple drives. The worst case condition occurs when all the drives are running simultaneously. In this case, just add up the power supply currents for each to determine the total power supply current requirement.

## Regeneration

If you plan to use a regulated power supply you may encounter a problem with regeneration. If you rapidly decelerate a load from a high speed, much of the kinetic energy of that load is transferred back to the power supply. This can trip the overvoltage protection of a switching power supply, causing it to shut down. Unregulated power supplies are better because they generally do not have overvoltage protection and have large capacitors for storing energy coming back from the drive. They are also less expensive. See previous section on *Connecting the Power Supply* for details on the RC-050 regeneration clamp.

## System Wiring Recommendations

1. Separate the DC power supply cable by at least 2" from the small signal input cable and the encoder feedback cable.
2. A shielded cable for the DC power supply connections will result in a quieter system. Ground the shield at the power supply.
3. A shielded cable is recommended for the small signal connections. Ground the shield at the signal source.

## Connecting the Motor



**Never connect or disconnect the motor while the power is on.**

*If the motor has a shield or grounding wire, please connect it to the chassis ground screw located on the chassis near the motor-power connector.*



**Chassis Ground Screw**

### Four Lead Motor

These motors can only be connected one way. Please follow the sketch below.

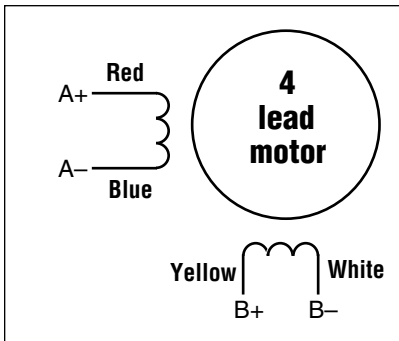

**4 Leads**

### MOTOR/POWER CONNECTOR

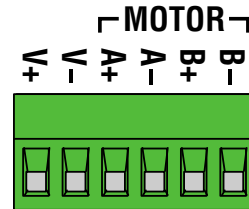

### Eight Lead Motor

These motors can be connected in series or parallel. A series connected motor needs less current than one that is connected in parallel but it will not be able to run as fast. Once you have determined which way you want to connect your motor to the drive, please follow the wiring diagrams below.

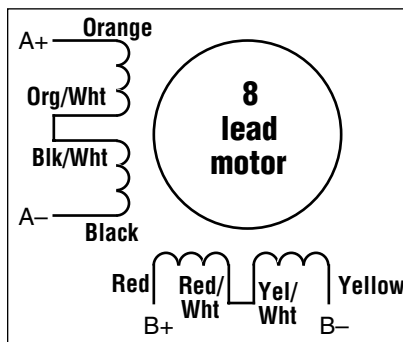

**8 Leads Series Connected**

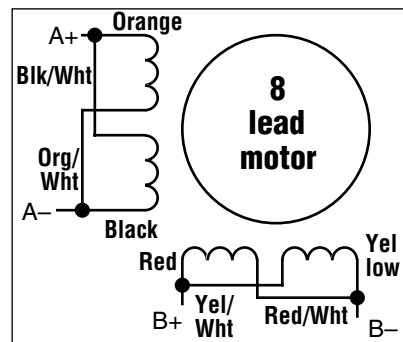

**8 Leads Parallel Connected**

### Connecting Input Signals

The STR2M drive has three inputs:

- STEP: a high speed digital input for step pulse commands, 5-24 volt logic
- DIR: a high speed digital input for the direction signal, 5-24 volt logic
- EN: a 5-24V input for commanding the removal of power from the motor

Note: STEP and DIR inputs can be converted to STEP CW and STEP CCW by moving the internal jumper. See "Step 6: Step Pulse Type".

### Connector Pin Diagram

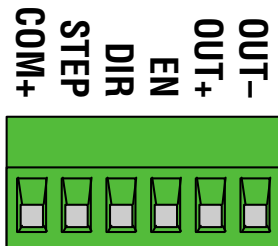

### Internal Circuit Diagram

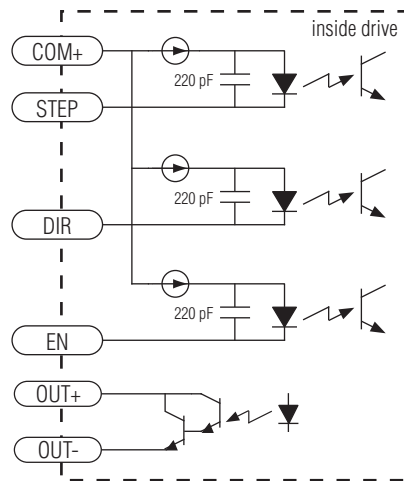

### Connection Examples: STEP & DIR

See "System Wiring Recommendations" for cable instructions

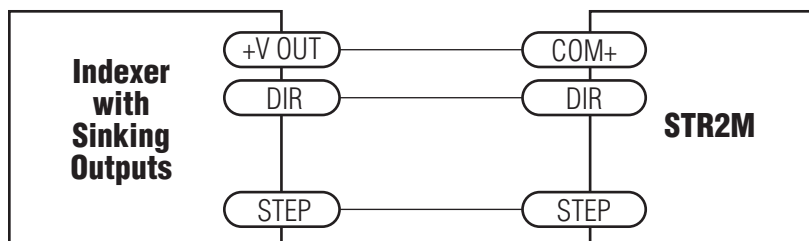

Connecting to Indexer with Sinking Outputs

**Connection Examples: EN**

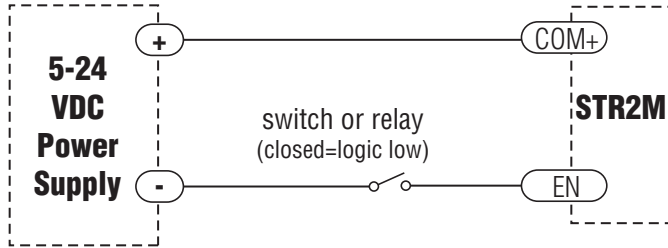

**Connecting an Input to a Switch or Relay**

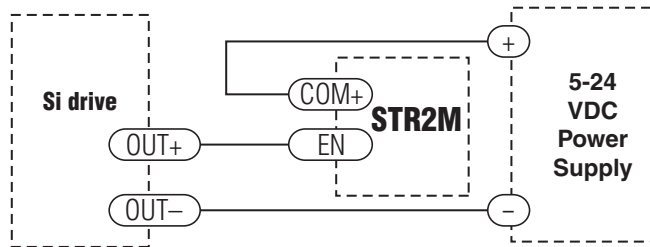

**Connecting another drive to EN**

*(When output closes, input closes)*

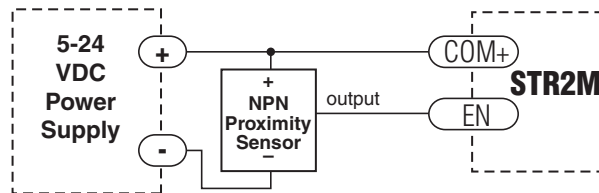

**Connecting an NPN Type Proximity Sensor to an input**

*(When prox sensor activates, input closes)*

## FAULT Output

The STR2M features a digital FAULT output. This output closes to signal a fault condition.

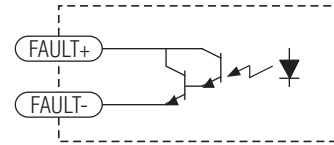

This output can be used to drive LEDs, relays and the inputs of other electronic devices like PLCs. The "+" (collector) and "-" (emitter) terminals of the output transistor are available at the connector. This allows you to configure the output for current sourcing or sinking.



Diagrams of each type of connection follow.

**Do not connect the output to more than 30VDC.**

**The current through the output terminal must not exceed 80 mA.**

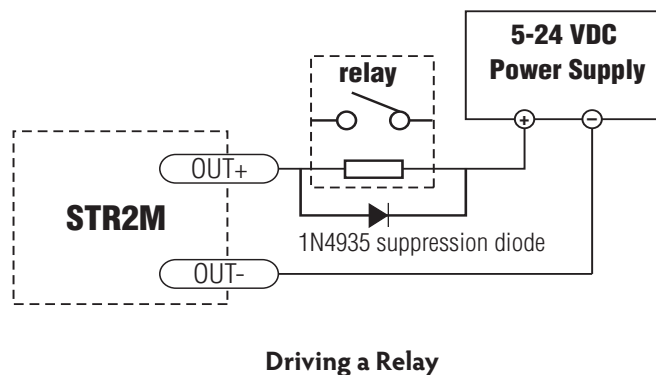
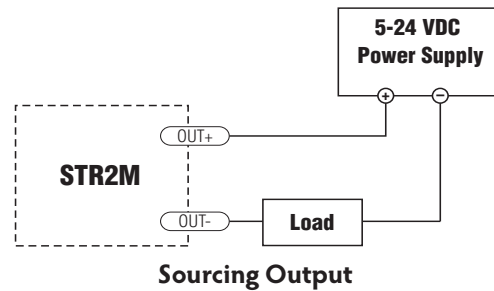
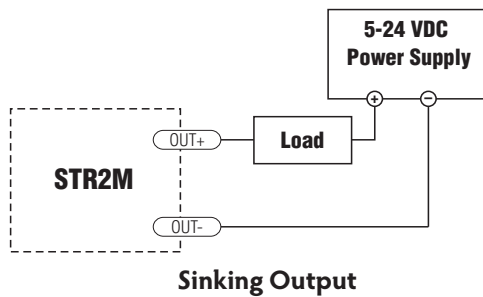

## Configuring the Drive

### Step 1: Setting the Current

To select a current, simply move switches A1, A2 and A3 to the setting that corresponds to the motor of your choice. You can do this while power is on, but it is safer to select the motor before applying power to the drive so that you do not risk applying too much current to your motor.

| A/PHASE | A1  | A2  | A3  |
|---------|-----|-----|-----|
| 0.25    | ON  | ON  | ON  |
| 0.5     | OFF | ON  | ON  |
| 0.7     | ON  | OFF | ON  |
| 1.0     | OFF | OFF | ON  |
| 1.3     | ON  | ON  | OFF |
| 1.6     | OFF | ON  | OFF |
| 1.9     | ON  | OFF | OFF |
| 2.2     | OFF | OFF | OFF |

### Step 2: Setting Idle Current

Motor heating and power consumption can also be reduced by lowering the motor current when it is not moving. The STR2M will automatically lower the motor current when it is idle to either 50% or 90% of the running current. The 50% idle current setting will lower the holding torque to 50%, which is enough to prevent the load from moving in most applications. This reduces motor heating by 75%. In some applications, such as those supporting a vertical load, it is necessary to provide a high holding torque. In such cases, the idle current can be set to 90% as shown below. The idle current switch is located in switch bank A, on the front of the STR2M

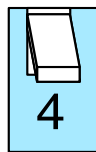

**50%**

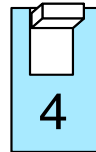

**90%**

### Step 3: Load Inertia

The STR2M drives include anti-resonance and electronic damping features which greatly improve motor performance. To perform optimally, the drive must understand the electromechanical characteristics of the motor and load. You must set switch B4 to indicate the approximate inertia ratio of the load and motor. The ranges are 0 to 4X and 5 to 10X. The motors table shown in Step 1 of this section include the rotor inertia of each motor. Please divide the load inertia by the rotor inertia to determine the ratio, then set switch B3 as shown. For assistance in calculating the load inertia of your application contact our Applications department.

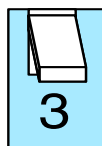

**5-10X**

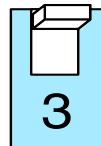

**0-4X**

**Step 4: Step Size**

The STR2M requires a source of step pulses to command motion. This may be a PLC, an indexer, a motion controller or another type of device. The only requirement is that the device be able to produce step pulses whose frequency is in proportion to the desired motor speed, and be able to smoothly ramp the step speed up and down to produce smooth motor acceleration and deceleration.

Smaller step sizes result in smoother motion and more precise speed, but also require a higher step pulse frequency to achieve maximum speed. The smallest step size of the STR2M is 1/25600th of a motor turn. To command a motor speed of 50 revolutions per second (3000 rpm) the step pulses frequency must be  $50 \times 25600 = 1.28$  MHz. Many motion devices, especially PLCs cannot provide step pulses at such a high speed. If so, the drive must be set for a lower number of steps per revolution. Sixteen different settings are provided in the STR2M drive, as shown in the table on the next page.

Please choose the one that best matches the capability of your system.

At lower step resolutions such as 200 steps/ rev (full step) and 400 steps/rev (half step), motors run a little rough and produce more audible noise than when they are microstepped (2000 steps/rev and beyond). The STR2M drives include a feature called "microstep emulation", also called "step smoothing", that can provide smooth motion from coarse command signals. By setting switch B2 ON, this feature is automatically employed to provide the smoothest possible motion from a less than ideal signal source.

Because a command filter is used as part of the step smoothing process, there will be a slight delay, or "lag" in the motion. If this delay is objectionable for your application, please turn the step smoothing filter off. The chart on the next page shows an example of the delay that can occur from using the step smoothing filter.

| STEPS/REV | A5  | A6  | A7  | A8  |
|-----------|-----|-----|-----|-----|
| 200       | ON  | ON  | ON  | ON  |
| 400       | OFF | ON  | ON  | ON  |
| 800       | OFF | OFF | ON  | ON  |
| 1600      | OFF | OFF | ON  | ON  |
| 3200      | ON  | ON  | OFF | ON  |
| 6400      | OFF | ON  | OFF | ON  |
| 12800     | ON  | OFF | OFF | ON  |
| 25600     | OFF | OFF | OFF | ON  |
| 1000      | ON  | ON  | ON  | OFF |
| 2000      | OFF | ON  | ON  | OFF |
| 4000      | ON  | OFF | OFF | OFF |
| 5000      | OFF | OFF | ON  | OFF |
| 8000      | ON  | ON  | OFF | OFF |
| 10000     | OFF | ON  | OFF | OFF |
| 20000     | ON  | OFF | OFF | OFF |
| 25000     | OFF | OFF | OFF | OFF |

Motion Profile with Step Smoothing Filter

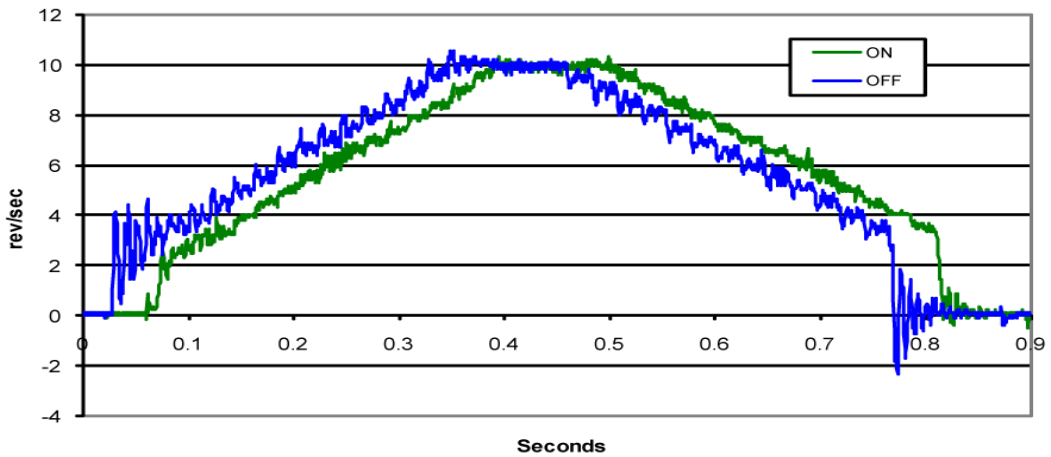

### Step 5: Step Pulse Type

Most indexers and motion controllers provide motion commands in the "Step and Direction" format. The Step signal pulses once for each motor step and the direction signal commands direction. However, a few PLCs use a different type of command signal: one signal pulses once for each desired step in the clockwise direction (called STEP CW), while a second signal pulses for counterclockwise motion (STEP CCW). The STR2M drives can accept this type of signal if you remove the drive cover and move jumper S3 from the "1-2" position to the "1-3" position. In STEP CW/STEP CCW mode, the CW signal should be connected to the STEP input and the CCW signal to the DIR input.

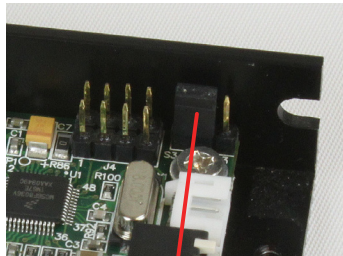

Step & Direction

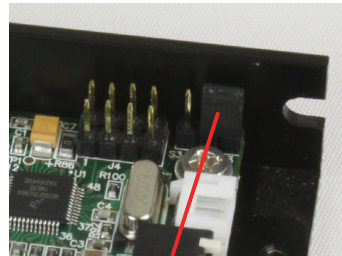

STEP CW & STEP CCW

### Step 6: Step Pulse Noise Filter

Just when you thought there couldn't be any more to know about step signals, we present one more setting for your consideration. Electrical noise can affect the STEP signal in a negative way, causing the drive to think that one step pulse is two or more pulses. This results in extra motion and inaccurate motor and load positioning. To combat this problem, the STR2M drives include a digital noise filter on the STEP and DIR inputs. There are two settings for this filter: 150 kHz works well for most applications. If you are operating the STR2M at a high number of steps/rev and at high motor speeds, you will be commanding the drive at step rates above 150 kHz. In such cases, you should use the 2 MHz setting as shown below. The step noise filter is controlled by switch 4 of the small bank of switches.

Your maximum pulse rate will be the highest motor speed times the steps/rev. For example, 40 revs/second at 20,000 steps/rev is  $40 \times 20,000 = 800$  kHz. Please consider this when deciding if you must increase the filter frequency.

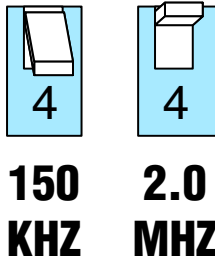

### Self Test

If you are having trouble getting your motor to turn, you may want to try the built-in self test. Anytime switch B1 is moved to the ON position, the drive will automatically rotate the motor back and forth, 2.5 turns in each direction. This feature can be used to confirm that the motor is correctly wired, selected and otherwise operational.

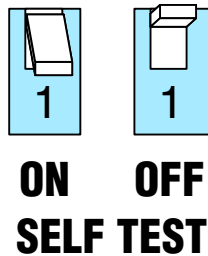

## Drive Heating

While STR2M drivers efficiently transmit power between the power supply and motor, they do generate some heat in the process. This will cause the temperature of the drive to rise above the surrounding air temperature and may also require that the drive be mounted to a heat conducting metal surface.

For those who wish to calculate the power dissipation and temperature rise, the following information is provided:

1. drive power dissipation  $P_d$  versus motor current and power supply voltage (see chart)
2. drive thermal constant  $R_{\theta}$

The final drive case temperature is given by

$$T_c = T_a + R_{\theta} * P_d$$

where  $T_a$  is the ambient temperature of the surrounding air. The case of the drive should not be allowed to exceed 70°C or the life of the product could be reduced.

Drive thermal constant:

Narrow side of drive mounted on a 13.5" x 13.5" steel plate, .070" thick:  $R_{\theta} = 1.84^{\circ}\text{C/W}$

Narrow side of drive mounted on a non-heat conducting surface:  $R_{\theta} = 3.99^{\circ}\text{C/W}$

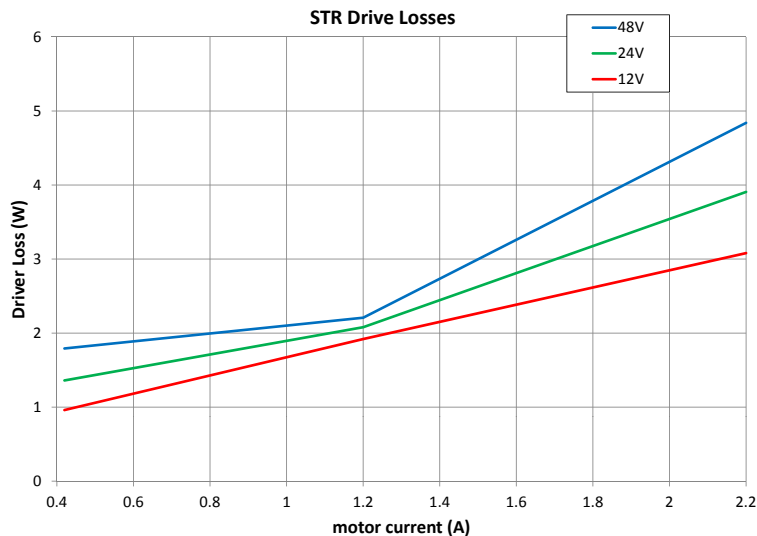

### Mechanical Outline

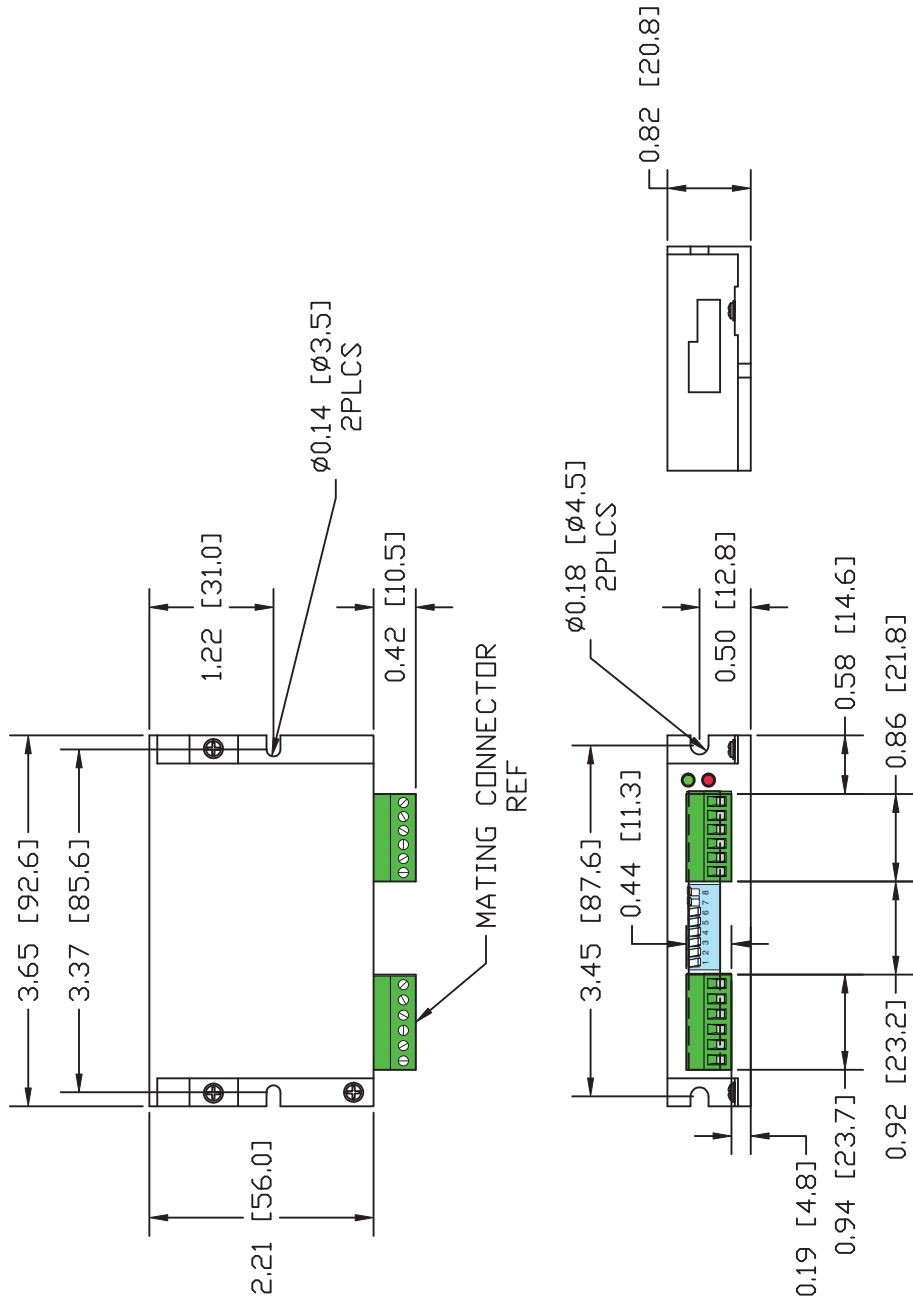

## Technical Specifications

### Amplifier

Digital MOSFET. 16 kHz PWM. Suitable for driving two phase step motors with four, six or eight leads.  
Protection against over-voltage, under-voltage, over-temp, and short circuit.

Supply voltage:

12-48 VDC

Under voltage alarm: 10 VDC

Over voltage shutdown: 52 VDC

Motor current:

0.3 to 2.2 amps/phase peak of sine

### Digital Inputs

Optically isolated, 5 - 24V logic. Sinking (NPN) signals must be used. Drive steps on rising edge of STEP input.

Minimum "on" voltage: 4 VDC.

Maximum voltage: 30 VDC.

Input current: 5 mA typ at 4V, 15 mA typ at 30V.

Maximum pulse frequency: 150 kHz or 2 MHz (set by switch)

Minimum pulse width:

3 usec (at 150 kHz setting)

0.25 usec (at 2 MHz setting)

### Fault Output

Photodarlington, 80 mA, 30 VDC max. Voltage drop: 1.2V max at 80 mA.

### Physical

0.82 x 2.21 x 3.65 inches (20.8 x 56 x 92.6 mm) overall.

4.7 oz (133 g) including mating connectors.

Ambient temperature range: 0°C to 50°C.

Operating temperature range: 0°C to 85°C (interior of electronic section).

## Mating Connectors and Accessories

### Mating Connectors

Motor/power supply: Phoenix Contact 1803617, included with drive.

Signals: Phoenix Contact 1840405, included with drive.

### Accessories

Regeneration Clamp:

Applied Motion Products [RC-050](#).

## Alarm Codes

In the event of a drive fault or alarm, the green LED will flash one or two times, followed by a series of red flashes. The pattern repeats until the alarm is cleared.

| Code                    | Error                         |
|-------------------------|-------------------------------|
| ● solid green           | no alarm, motor disabled      |
| ●● flashing green       | no alarm, motor enabled       |
| ●●● 1 green, 3 red      | over temperature              |
| ●●●● 2 green, 3 red     | internal voltage out of range |
| ●●●●● 1 green, 4 red    | power supply voltage too high |
| ●●●●●● 2 green, 4 red   | power supply voltage too low  |
| ●●●●●●● 1 green, 5 red  | over current / short circuit  |
| ●●●●●●●● 1 green, 6 red | open motor winding            |

## Connector Diagrams

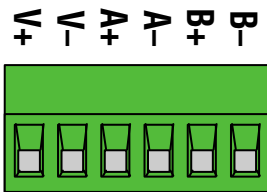

Power and Motor Connector

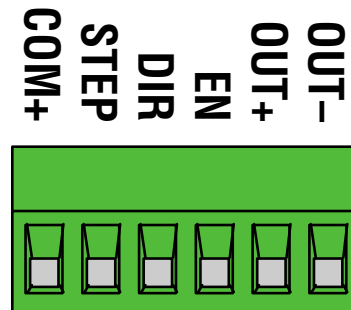

Signal Connector

404 Westridge Drive Watsonville, CA 95076  
 Tel (831) 761-6555 (800) 525-1609 Fax (831) 761-6544  
[www.applied-motion.com](http://www.applied-motion.com)