



Material Safety Data Sheet

Section 1 Company and Product Identification

L. Robinson & Company (Gillingham) Limited, Incorporating Jubilee Clips Limited
Owens Way, Gads Hill, Gillingham, Kent, ME7 2RS

Tel: +44 (0)1634 281200

Fax: +44 (0)1634 280101

Email: sales@jubileeclips.co.uk

Jubilee Multiband Stainless Steel Range

Description	Working Diameter		Band Thickness mm	Recommended Torque Nm	Max Torque Nm	Max Pressure PSI
	Min mm	Max mm				
Band	40	1000	0.82	3.4	4.5	N/A

Description	Height	Width	Length	Fastening
Stainless Steel Solid Housing and Screw	15.00mm	15.75mm	18.72mm	7mm AF Hex
Stainless Steel Captive Housing and Screw	16.25mm	18.80mm	23.85mm	7mm AF Hex

Part No.	Description
MB1801	11mm Banding 10m
MB1802	11mm Banding 30m
MB1803	25 x 11mm Housing and 7mm AF screws
MB1804	25 x 11mm Housing and Allen screws
MB1805	25 x 11mm Captive Screws
MB1806	11mm Handy Pack 10m Band & 25 Housings & Screws

Captive housing and screw

Solid Housing and screw

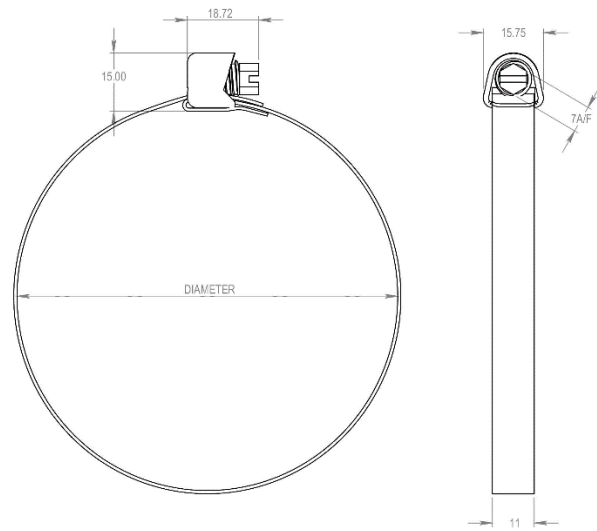
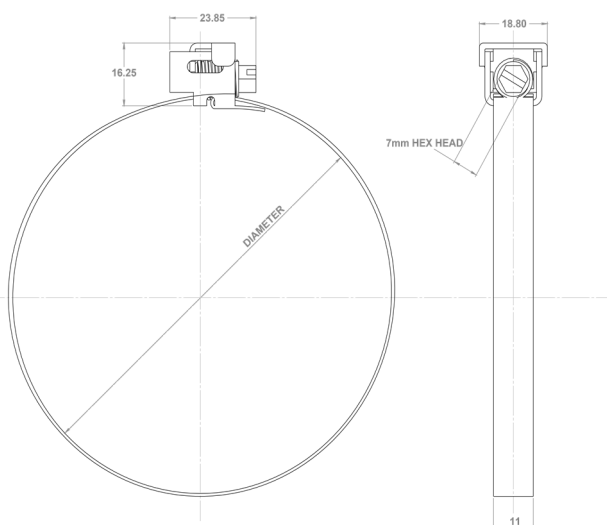

Section 2 Composition/Information on Ingredients

Composition/Information on constituents of iron alloy.

Manganese	< 11%
Chromium	< 30%
Nickel	< 38%
Mo	< 8 %

Other elements vary such as Si, Cu, Ti, in each alloy composition and are generally not classified as hazardous, or are below the concentration levels for classification of these alloys as hazardous, and are not subject to recognised exposure limits.

Section 3 First Aid Measures

Inhalation:	There are no specific symptoms associated with steel in the product forms.
Skin:	There are no specific symptoms associated with steel in the product forms.
Eyes:	Not applicable.
Ingestion:	Not applicable.

Section 4 Fire Fighting Measures

Non flammable

Section 5 Handling and Storage

Store in a dry area

Section 6 Physical and Chemical Properties

Colour:	Metallic grey/silver
Smell:	None
Form/state:	Solid
Melting point:	1454 °C
Max service temp:	870 °C
Min service temp:	-196 °C
Magnetism:	1.008 μ
Resistance:	72 μΩ
Density:	8.03 g/cm ³

Section 7 Stability and Reactivity

Stability:	Stable in normal condition
Reacts with:	Reacts with strong acids, and hydrogen is then one of the substances emitted. Welding/flame cutting may produce Zinc Oxide fumes.
Corrosion Resistance:	NSS (Neutral Salt Spray tests) 1000hours

Section 8 Toxicological Information

Nickel is classified as a skin sensitizer whoever numerous patch tests have established that most stainless steels do not cause sensitisation, but a few types may result in allergic skin reactions in sensitised individuals after prolonged contact.

No carcinogenic effects resulting from exposure to stainless steels have been reported, either in epidemiological studies or in tests with animals.

Section 9 Ecological Information

No ecological effects are known for the product as a whole.

Section 10 Disposal Considerations

Disposal method: Recyclable, Jubilee® clips' Stainless Steel Multiband range is made from key raw material for the production of new steel. Steel is the world's most recycled construction material and can be recycled with retained material properties.

Section 11 Transport Information

No special requirements are necessary in transporting these products.

Section 12 Regulatory Information

This product conforms to EU Regulation 1097/2006 (REACH)
This product is compliant with EU directive 2011/65/Eu (ROHS2)
BS EN ISO 9001:2008 FM00547
BS EN ISO 14001:2004 EMS573195
BS OHSAS 18001:2007 OHS601983

Section 13 Other Information

The information above is believed to be accurate and represents the best information currently available to L. Robinson & Co Ltd. However, L. Robinson & Co Ltd make no warranty of merchantability or any other warranty, expressed or implied, with respect to such information, and we assume no liability resulting from its use. Users should make their own investigations to determine the suitability of the information for their particular purposes. In no event shall L. Robinson & Co Ltd be liable for any claims, losses, or damages of any third party or for lost profits or any special, indirect, incidental, consequential or exemplary damages, howsoever arising, even if L. Robinson & Co Ltd has been advised of the possibility of such damages.

Issue Date: 10th February 2015

Revision Number: 11

Doc: JMSDSMB11SS1110215