

Basic Series • Accessories

Low Voltage Current Transformer Class 1

Current Transformer

Current transformers for direct mounting to bus bars or insulated round conductors.
Application: indirect measurement of sinusoidal alternating current.



ASK 31.3

Type	ASK 31.3	ASK 412.4
For Bars up to	30 x 10 mm 25.4 x 13 mm 2 x 20 x 10 mm	40 x 12 mm 30 x 15 mm —
For Round Conductors to	∅ 26 mm	∅ 30.5 mm
Rated Primary Current	50 to 750 A	50 to 1000 A
Class	1	1
Housing Material	polycarbonate	polycarbonate
Transformer Width	60 mm	70 mm
Weight max.	0.28 kg	0.45 kg

Technical Data, Characteristic Values

Polycarbonate housing per	UL 94 V-0
Angle bracket and rail Screw Clip Screws with insulated protective cover as standard mount (rail Screw Clip Screws only with plug-on current transformer)	
Tightening torque for rail Screw Clip Screws	2 ... 3 Nm
Maximum device voltage U_m (effective value) = max. allowable operating voltage	0.72 kV
Rated short-time alternating withstand voltage (effective value) = test voltage	3 kV
Ambient temperature (operating temperature range)	- 5 ... 40 °C (no condensation)
Design valid for	40 °C ambient temperature and 70 °C bus bar temperature
Rated thermal continuous current	$1.0 \times I_n$
Rated frequency	50 ... 60 Hz
Rated thermal short-time current	$60 \times I_n$
Insulation class	E
Overcurrent limiting factor (FS)	FS 5 to 1500 A rated primary current FS 10 from 1600 A rated primary current

Basic Series • Accessories

Current Transformer Class 1

Type ASK 31.3

Primary Conductor 30 x 10 mm
25.4 x 13 mm
2 x 20 x 10 mm

Round Conductor \varnothing 26 mm

Transformer Width 60 mm

Rated Primary Current A	VA	Sec. 5 A	Sec. 1 A
		Order No. 1715V + ↓	Order No. 1715V + ↓
50	1.0	0100	1100
60	1.0	0110	1110
75	1.5	0120	1120
80	2.5	0130	1130
100	2.5	0140	1140
150	2.5	0150	1150
200	5	0160	1160
250	10	0170	1170
300	10	0180	1180
400	10	0190	1190
500	10	0200	1200
600	10	0210	1210
750	10	0220	1220

Accessories:	Order No.
Adaptor for 35 mm mounting rail to DIN EN 50 022	1722V9010
Protective cover	1722V9110

Dimensional Drawing

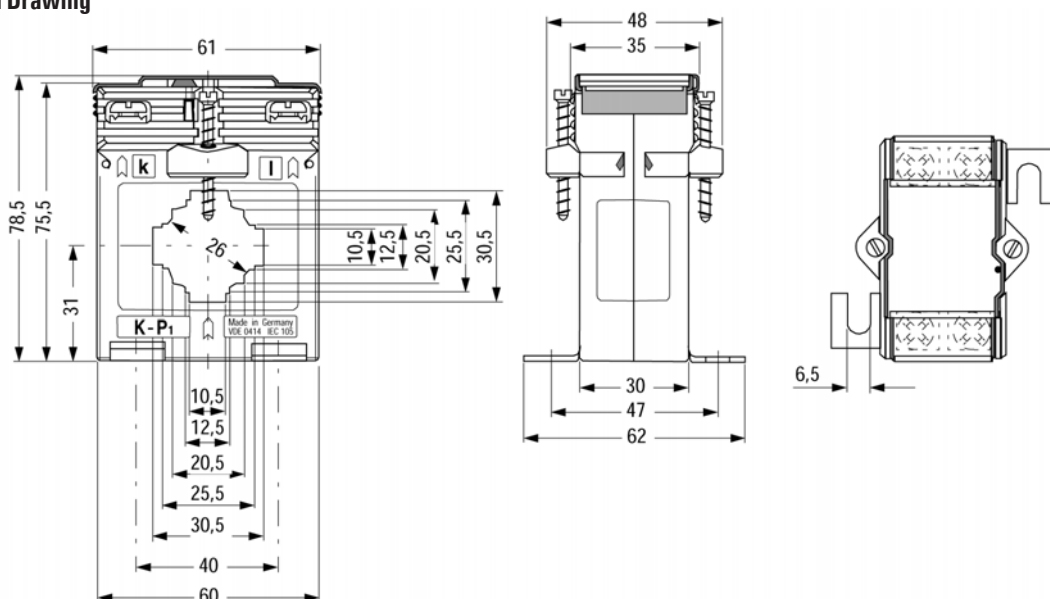

Basic Series • Accessories

Current Transformer Class 1

Typ ASK 412.4

Primary Conductor 40 x 12 mm
30 x 15 mm

Round Conductor \varnothing 30.5 mm

Transformer Width 70 mm

Rated Primary Current A	VA	Sec. 5 A	Sec. 1 A
		Order No. 1716V + ↓	Order No. 1716V + ↓
50	1.5	0100	1100
60	1.5	0110	1110
75	2.5	0120	1120
80	2.5	0130	1130
100	3.75	0140	1140
150	5	0150	1150
200	10	0160	1160
250	10	0170	1170
300	10	0180	1180
400	10	0190	1190
500	10	0200	1200
600	10	0210	1210
750	10	0220	1220
800	10	0230	1230
1000	10	0240	1240

Accessories:	Order No.
Adaptor for 35 mm mounting rail to DIN EN 50 022	1722V9020
Protective cover	1722V9120

Dimensional Drawing

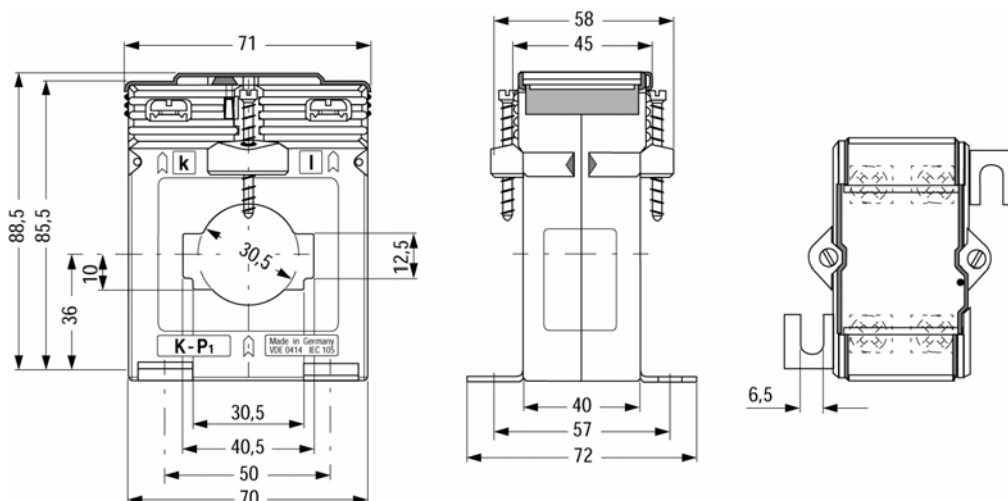

Basic Series • Accessories

Shunt Resistors Class 0.5



Shunt Resistor

Technical Data

Type	60 mV
Accuracy Class per DIN EN 60 051	0.5
Dimensions per	DIN 43 703 ¹⁾
Balancing	An instrument power consumption value of 6 mA is taken into consideration for balancing when shunts are used.

1) Model with insulation base can be screw or snap mounted (for top-hat rail per DIN EN 50022-35), overall length: 140 mm.
Overall height for model with cover is increased to 40.5 mm

Ordering Example

Technical Data	Order No.
Shunt Resistor, Nominal Current: I_N 250 A, Voltage Drop: 60 mV	1700V3340

Nominal Current I_N	Type 60 mV	
	Weight kg. approx.	Order No.
1 A	0.10	1700V3010 ◇
1.5 A	0.10	1700V3030 ◇
2.5 A	0.10	1700V3050 ◇
4 A	0.10	1700V3070 ◇
6 A	0.10	1700V3090 ◇
10 A	0.10	1700V3110 ◇
15 A	0.10	1700V3130 ◇
25 A	0.10	1700V3170 ◇
40 A	0.10	1700V3200
60 A	0.10	1700V3230
100 A	0.10	1700V3280
150 A	0.15	1700V3300
250 A	0.50	1700V3340
400 A	0.70	1700V3370
500 A	1.00	1700V3390
600 A	1.20	1700V3400
1000 A	1.45	1700V3460
40 A	0.10	1700V7200 ◇
60 A	0.10	1700V7230 ◇
100 A	0.10	1700V7280 ◇
150 A	0.15	1700V7300 ◇

◇ On insulating base (screws or snaps onto top-hat rail per DIN EN 50 022-35)

◇ Cover for shunt resistor on insulating base: **Order No. 1700V8210**

Basic Series • Accessories

Shunt Resistors Class 0.5

Drawings to Scale

Dimensions in mm

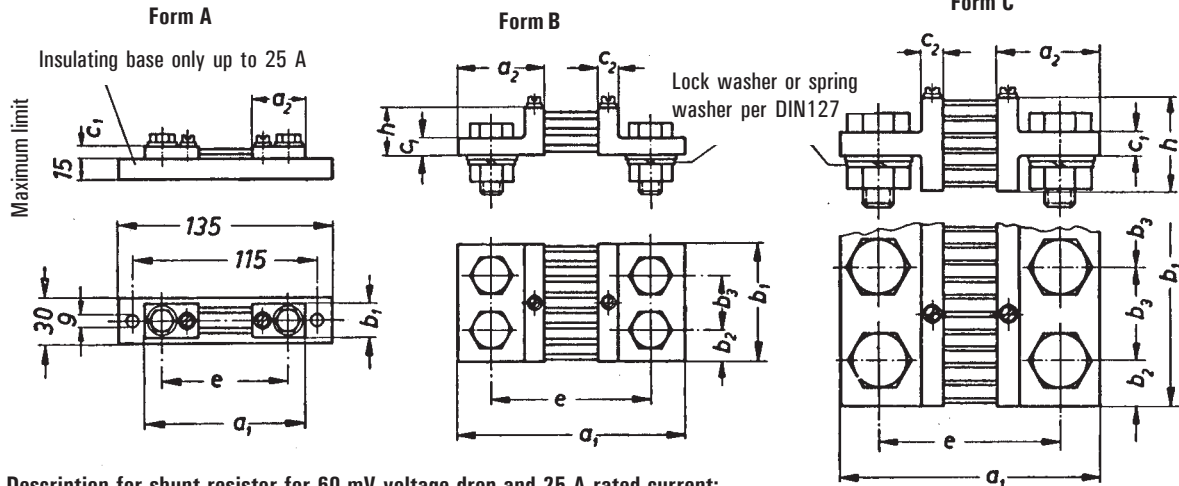

Description for shunt resistor for 60 mV voltage drop and 25 A rated current:

Shunt Resistor 60/25 DIN EN 60051

Voltage Drop mV	Dim.	For rated current in A																		
		1	1.5	2.5	4	40	60	250	400	600	1000	1500	2500	4000	6000	10000	15000			
60		Form A				Form B				Form C										
	a ₁	90				100				145				165				165	175	185
	a ₂	28				33				55				65				65	70	75
	b ₁			20				30	40		60	90	120		120	154	206	310		
	b ₂							15	20		30	21	30		30			25		
	b ₃											48	60		60			52		
	c ₁			8							10				15	25	30			
	c ₂										10				10	15	20			
	e	78		80				105			115				115	125	135			
	h										30				60	130	170			
150		Form A				Form B				Form C										
	a ₁	90				225				270				290				290	300	310
	a ₂	28				33				55				65				65	70	75
	b ₁	20		25				30	40		70	90	120		154	206	310			
	b ₂							15	20		35	21	30		30			25		
	b ₃											48	60		60			52		
	c ₁			8							10				15	25	30			
	c ₂										10				10	15	20			
	e	78		205				230		240	240	240			250	260				
	h							50		60	60	60			130	170				
Number of supply terminals					2x1				2x2				2x3	2x4	2x6					
Hexagonal bolt DIN 933-5	M 5x12 ⁵⁾		M 8x15 ⁵⁾		M 12x40	M 16x45	M 20x50	M 16x45 ²⁾	M 20x50 ³⁾	M 20x60 ⁴⁾	M 20x75	M 20x85								
Washer DIN 125 - mild steel	5,3		8,4		13,5	17	21	17	21											
Nut DIN 934-5					M 12	M 16	M 20	M 16	M 20											
Voltage terminals	2 socket-head capscrews AM 5 x 8 DIN 84-4 and washer 5.3 DIN 433, mild steel																			

Unspecified details are to be selected appropriate.

Accuracy class 0.5 per DIN 57 410, rules for measuring instruments.

Shunts exchangeable, if power consumption of measuring instrument connected does not exceed 500 μW.

¹⁾ To maintain a constant contact pressure, place a lock washer or a spring washer between the washer and the nut

²⁾ For 150 mV: bolt M 16 x 60 ³⁾ For 150 mV: bolt M 20 x 60

⁴⁾ For 150 mV: bolt M 20 x 75

⁵⁾ When bolts M 5 and M 8 are available, use preferably M 5 per DIN 267