



Features

- 0603 package
- Rated for IEC 61000-4-2, level 4 ESD requirements for high speed USB 2.0 or IEEE1394 applications
- Withstands multiple ESD strikes
- Low capacitance and leakage currents for invisible load protection
- Tape and reel packaging

ChipGuard® MLC Series Varistor ESD Clamp Protectors

Description

The ChipGuard® CG0603MLC Series has been specifically designed to protect sensitive electronic components from electrostatic discharge damage. The MLC family has been designed to protect equipment to IEC61000-4-2, level 4 ESD specifications targeted for high speed USB 2.0 or IEEE1394 applications. The ChipGuard® MLC Series has been manufactured to provide very low capacitance and leakage currents with excellent clamp qualities, making the family almost transparent under normal working conditions.

Device Symbol

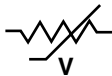

How to Order

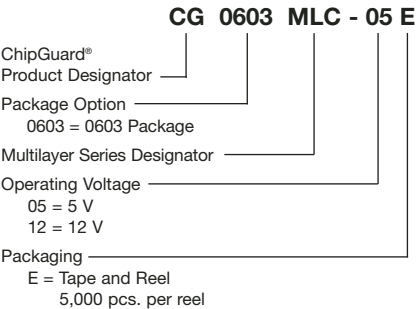

Ni barrier terminations are standard on all ChipGuard® part numbers.



Reliable Electronic Solutions

Asia-Pacific: TEL +886-2 25624117 • FAX +886-2 25624116
Europe: TEL +41-41 7685555 • FAX +41-41 7685510
The Americas: TEL +1-951 781-5500 • FAX +1-951 781-5700
www.bourns.com

Electrical Characteristics @ 25 °C (unless otherwise noted)

Parameter	Device	Typ.	Max.	Unit
V _{DC} Continuous operating voltage	CG0603MLC-05 CG0603MLC-12	5 12	6	V
V _{CLAMP} Clamping voltage (see notes 1,2,3)	CG0603MLC-05 CG0603MLC-12	20 30	35 50	V
C _{off} Off-state capacitance, f = 1 MHz, 1 Vrms bias			0.5	pF
I _L Off-state current, V _{DC} = max. rating			50	nA
V _T Trigger voltage (see notes 1,3,4)		150		V

- Notes: 1. Per IEC 61000-4-2, 30 A at 8 kV, level 4.
 2. Measurement made 30 ns after initiation of pulse.
 3. Test conducted in contact discharge mode.
 4. Measurement made at maximum pulse voltage.

Environmental Characteristics

Response Time <1 ns
 Operating Temperature -55 °C to +85 °C
 Storage Temperature -55 °C to +85 °C

These products are RoHS compliant and considered lead free under the RoHS guidelines. As the component is a ceramic part, there is some lead contained within the glass of the ceramic. This is acceptable under exemption no. 5 of the RoHS directive (DIRECTIVE 2002/95/EC OF THE EUROPEAN PARLIAMENT AND OF THE COUNCIL of 27 January 2003 on the restriction of the use of certain hazardous substances in electrical and electronic equipment).

Surge Withstand Ratings

Parameter	Peak Voltage	Repetitions (Min.)
ESD Voltage Capability, Contact Discharge	8 kV	100 at 8 kV
ESD Voltage Capability, Air Discharge	15 kV	100 at 15 kV
Standard	IEC61000-4-2 Level 4	

*RoHS Directive 2002/95/EC Jan 27 2003 including Annex.
 Specifications are subject to change without notice.
 Customers should verify actual device performance in their specific applications.

ChipGuard® MLC Series Varistor ESD Clamp Protectors

BOURNS®

Product Dimensions

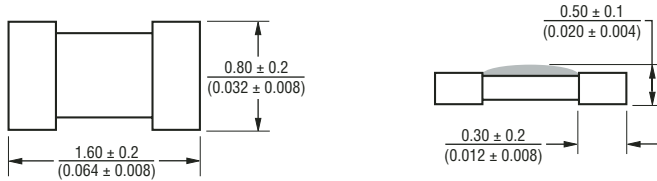

Recommended Pad Layout

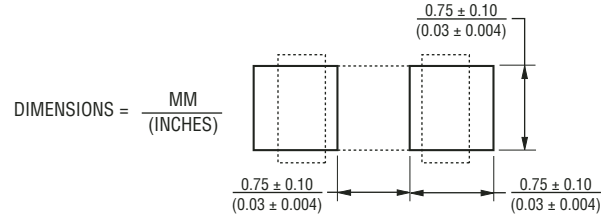

Packaging Dimensions

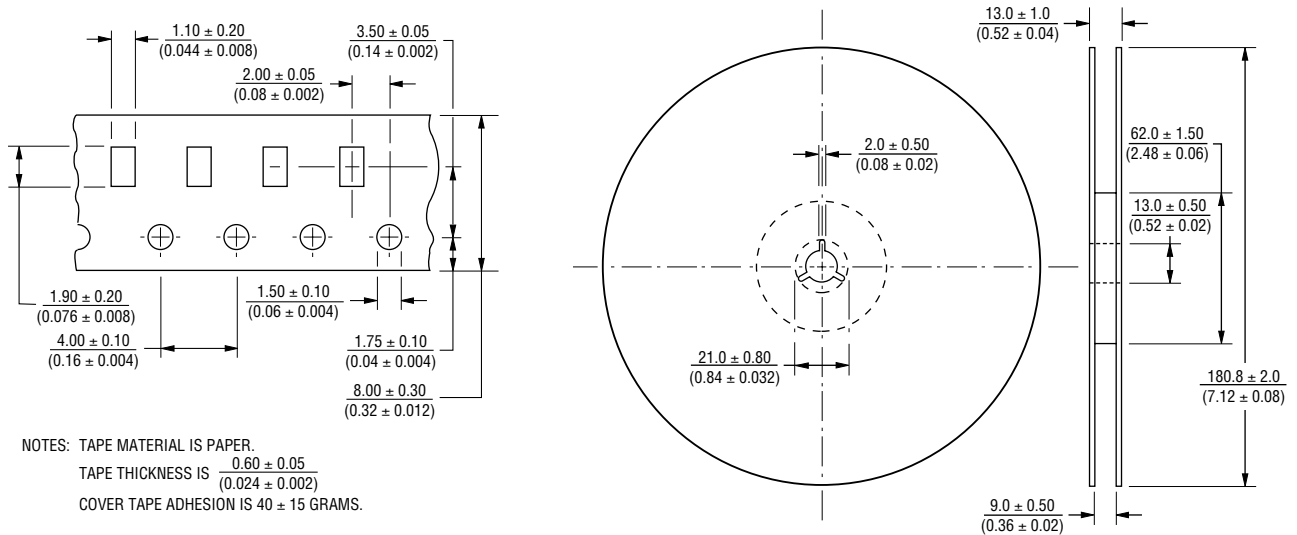

Solder Reflow Recommendations

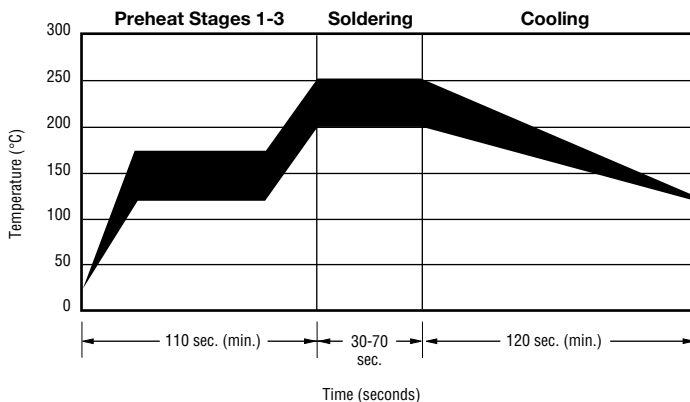

Stage	Description	Temperature	Time
A	Stage 1 Preheat	Ambient to Preheating Temperature	30 s to 60 s
B	Stage 2 Preheat	140 °C to 160 °C	60 s to 120 s
C	Stage 3 Preheat	Preheat to 200 °C	20 s to 40 s
D	Main Heating	200 °C 210 °C 220 °C 230 °C 240 °C	60 s to 70 s 55 s to 65 s 50 s to 60 s 40 s to 50 s 30 s to 40 s
E	Cooling	200 °C to 100 °C	1 °C/s to 4 °C/s

- ⚠ This product can be damaged by rapid heating, cooling or localized heating.
- Heat shocks should be avoided. Preheating and gradual cooling recommended.
- Excessive solder can damage the device. Print solder thickness of 150 to 200 um recommended.
- Solder gun tip temperature should be kept below 280 °C and should not touch the device directly. Contact should be less than 3 seconds. A solder gun under 30 watts is recommended.

REV. E 09/06

Specifications are subject to change without notice. Customers should verify actual device performance in their specific applications.

"ChipGuard" is a registered trademark of Bourns, Inc.