



Main

Range of product	Harmony XPE
Product or component type	Foot switch
Material	Plastic
Foot switch type	Single foot switch
Device short name	XPEB
Protective cover	Without
Trigger mechanism	Without trigger mechanism
Contacts operation	1 step
Contacts type and composition	1 NC + 1 NO
Colour	Blue

Complementary

Positive opening	With conforming to EN/IEC 60947-5-1 appendix K
Connections - terminals	Screw clamp terminal: $\leq 2 \times 1.5 \text{ mm}^2$ with or without cable end Screw clamp terminal: $\leq 1 \times 2.5 \text{ mm}^2$ with or without cable end
Cable entry	2 plain holes for M20 cable gland
Mechanical durability	10000000 cycles
[Ie] rated operational current	0.27 A, 250 V, DC-13, Q300 conforming to EN/IEC 60947-5-1 appendix A 3 A, 240 V, AC-15, A300
[Ui] rated insulation voltage	500 V, degree of pollution: 3 conforming to VDE 0110 group C 500 V, degree of pollution: 3 conforming to NF C 20-040 group C 500 V, degree of pollution: 3 conforming to EN/IEC 60947-1 300 V conforming to UL 508 300 V conforming to CSA C22-2 No 14
[Uimp] rated impulse withstand voltage	6 kV conforming to EN/IEC 60947-1
Resistance across terminals	$\leq 25 \text{ m}\Omega$ conforming to NF C 93-050 method A $\leq 25 \text{ m}\Omega$ conforming to IEC 60255-7 category 3
Short circuit protection	10 A by cartridge fuse type gG conforming to VDE 0660-200 10 A by cartridge fuse type gG conforming to EN/IEC 60947-5-1
Operational power in W	7 W DC-13, operating rate: 60 cyc/mn, 5000000 cycles, 48 V, load factor: 0.5 conforming to EN/IEC 60947-5-1 appendix C 4 W DC-13, operating rate: 60 cyc/mn, 5000000 cycles, 120 V, load factor: 0.5 conforming to EN/IEC 60947-5-1 appendix C 10 W DC-13, operating rate: 60 cyc/mn, 5000000 cycles, 24 V, load factor: 0.5 conforming to EN/IEC 60947-5-1 appendix C
Product weight	0.57 kg

Environment

Standards	CSA C22-2 No 14 EN/IEC 60947-5-1 UL 508
Product certifications	CSA UL
Protective treatment	TH
Ambient air temperature for operation	-25...70 °C
Ambient air temperature for storage	-40...70 °C
Vibration resistance	5 gn (f = 10...500 Hz) conforming to IEC 60068-2-6
Shock resistance	30 gn conforming to IEC 60068-2-27
Class of protection against electric shock	Class II conforming to NF C 20-030 Class II conforming to EN/IEC 61140
IP degree of protection	IP66 conforming to IEC 60529

Plastic Foot Switch without Protective Cover

Dimensions

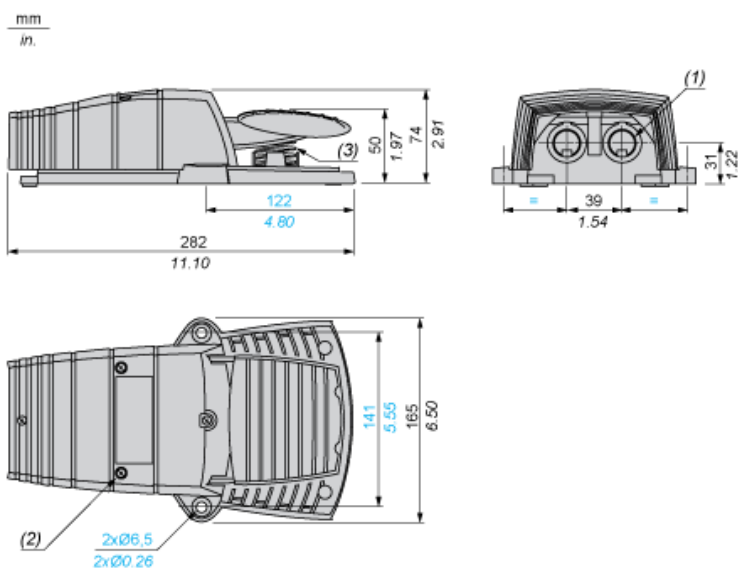

- (1) 2 plain holes for ISO M20 or n° 13 (Pg 13.5) cable gland.
- (2) 4 cover fixing screws: stainless steel. Tightening torque: 1 N.m.
- (3) Return spring: stainless steel.

Electrical Durability of Contacts

AC-15 Utilization Category

Operating rate: 3600 operating cycles/hour. Load factor: 0.5.

Inductive circuit:

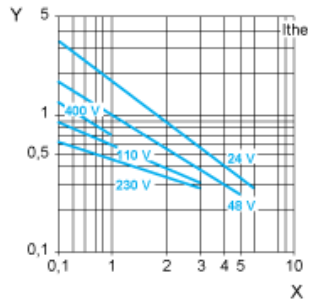

X Current in A
Y Millions of operating cycles

DC-13 Utilization Category

Refer to the product characteristic "Operational power in W".