

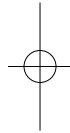

Installation Guide and User Manual

For BT Accord 30 Telephone Amplifier & Headset

Telephone and multimedia headset and amplifier kit with noise-cancelling microphone for BT Converse, most other corded telephones and multimedia PCs. Ideal for use in call centres and offices.



Includes:

- BT Accord 30 telephone amplifier
- BT Accord 20 telephone headset
- Phone cord to connect your BT Accord 30 to your telephone
- PC connection cable to connect your BT Accord 30 to your computer
- Screwdriver pin to adjust your microphone sensitivity

Replacement parts and accessories are available from your usual supplier or www.easidirect.co.uk

Before you start

The BT Accord 30 is simple to set-up and operate but please take the time to read this instruction manual to ensure you get the best from your equipment.

Your BT Accord 30 amplifier can be connected to your telephone and/or your computer. You can use it with either the BT Accord 20 headset supplied, or with a PC headset (not included).

Diagram key

1. External DC supply socket (6V DC to 9V DC-- an optional mains adaptor is available)
2. Telephone configuration switch
3. Line in socket (3.5mm, stereo) for computer line out connection
4. Line out socket (3.5mm, stereo) for computer line in connection
5. Power on/off switch
6. Microphone sensitivity control
7. Mute button
8. Telephone or computer selection switch
9. Computer headset socket (3.5mm, stereo) for speaker plug connection
10. Computer headset socket (3.5mm, stereo) for microphone plug connection
11. Headset or handset selection switch
12. Modular socket (RJ11) for telephone headset connection
13. Sliding volume control
14. Modular socket (RJ11) for telephone handset
15. Modular socket (RJ11) for connection from the telephone base unit
16. Battery compartment door (2 x "AA" size batteries required, not supplied)

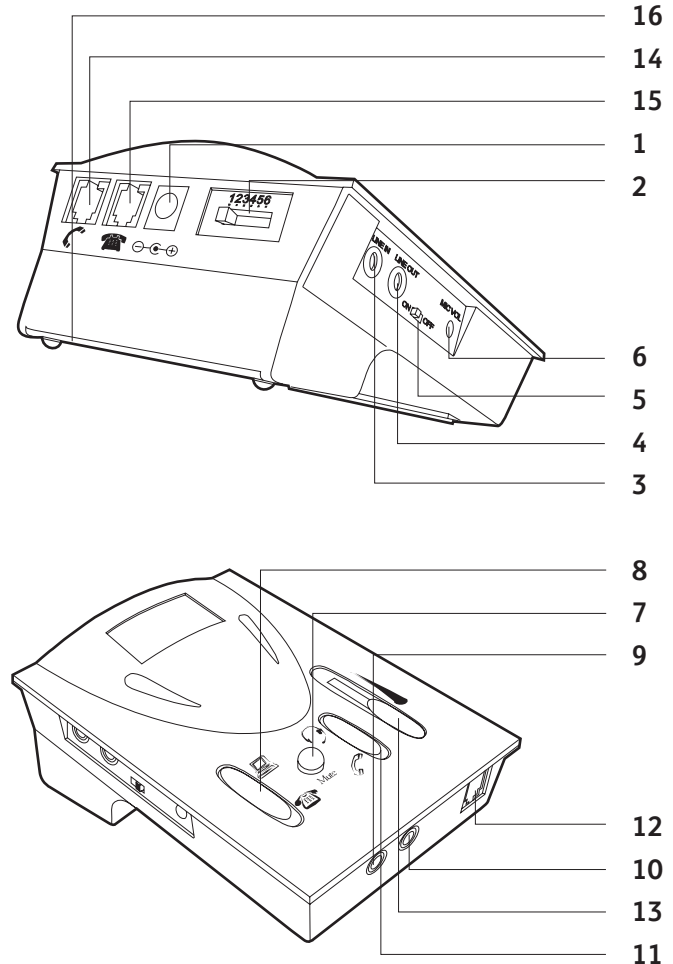

Connections

Connecting to the telephone

Unplug the handset cord from your telephone and plug it into the **handset modular socket (14)**. Connect the BT Accord 30 to your telephone using the phone cord provided (this cord has an RJ-11 modular plug on either end). Plug one end of the cord to your telephone from where you unplugged your handset **(A)** and the other end to the **telephone base unit modular socket (15)** on the back of the BT Accord 30 (see illustration below).

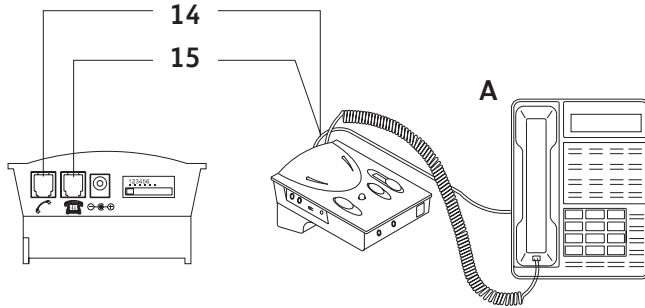

Connecting the telephone headset

Insert the telephone headset plug into the **RJ-11 modular socket (12)** on the front panel of the BT Accord 30. The headset socket will allow monaural (single ear) use.

- For telephone only use you will not need to connect numbers **3, 4, 9,** and **10** on the diagram on page 3.

Congratulations you are now connected!

Connecting to the computer

You may use the BT Accord 20 headset supplied or a computer headset if you already have one. Computer headsets are typically stereo (both ears) and may be more suitable for some applications (games etc).

To connect the BT Accord 30 to your computer you will need to use the long cable supplied with two jack plugs at each end. Connect the plugs from one end of the cable to the sockets **(3, 4)** on the diagram on page 3) matching the green and blue colours on socket and plug. Make the same connections to your computer's sound card.

- For computer only use you will not need to connect numbers **12, 14,** and **15** on the diagram on page 3.

Congratulations you are now connected!

Inserting batteries

The BT Accord 30 requires 2 x "AA" sized batteries (not supplied). To insert batteries slightly depress the compartment lid and slide outwards. Install batteries with polarities according to the battery diagram inside the compartment. Close the lid and turn the power "on" **(5)**. Alkaline batteries are recommended. If you find that the volume is too low and you cannot adjust it then this is typically an indication that the batteries need to be replaced.

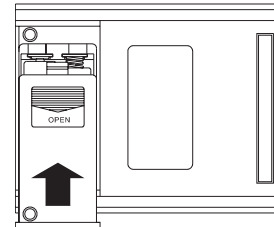

The power on/off switch (5)

The BT Accord 30 will switch to standby mode automatically after a period of inactivity. Turning off the unit does not affect normal telephone communication through the handset, so you can answer or make phone calls through the handset as usual.

Configuring the control unit

The **telephone configuration switch (2)** at the back of the BT Accord 30 allows you to select the most suitable setting for you to work with your telephone. To check your configuration put the headset on and move the **handset/headset switch (11)** to the headset position.

Please make sure you turn down the volume to protect your hearing.

Make sure the **telephone/computer switch (8)** is set to telephone position. Raise the telephone handset and move the 6-position configuration switch slowly until you can hear a clear dial tone.

Note that there may be two matching settings, choose the clearer setting or either one if both perform the same.

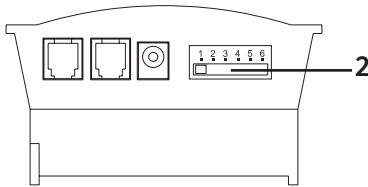

The controls

Telephone/computer selection switch

The **telephone/computer application switch (8)** is for you to select either telephone use or computer use.

Headset/handset selection switch

The **handset/handset application switch (11)** is for you to choose between using the handset of your telephone or the BT Accord 20 headset provided.

Mute switch

The **mute switch (7)** lets you place a caller on hold by pressing down to the mute position. The caller will not be able to hear you but you will still be able to hear the caller. To resume the call press the button again.

Volume control

The sliding **volume control (13)** is for adjusting the volume of the sound to the headset speaker. By sliding the button up and down, you can obtain the desired volume.

Microphone sensitivity control

The BT Accord 30 allows you to adjust the outgoing sound volume, and the high and low frequencies associated with it. To fine tune the transmission volume, place a call and talk as usual using the headset. Slowly rotate the **microphone sensitivity control (6)** with the small screwdriver pin provided until the desired level is reached. The person talking to you should be able to tell you when the optimum sound and tone level is reached. Once this is set, there should be no need to make further adjustments in the future.

Caution: Be careful when you adjust the volume control, as rotating the volume to maximum setting may cause the headset to “squeal”. Reduce the volume and the “squealing” will disappear, but continuous over-turning of the control may cause damage to the unit.

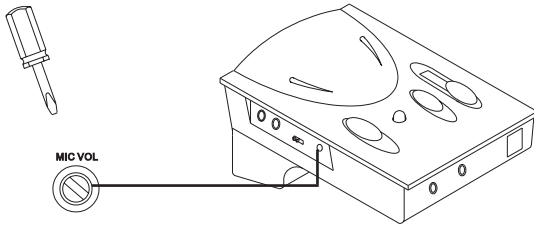

Operation

Making calls using the headset

- Switch to telephone position through the **telephone/computer selection switch (8)**.
- Make sure the headset position is selected on the **headset/handset selection switch (11)**.
- Lift up the handset from its cradle and place it “off-hook”, you should now hear a dial tone and may dial the number you require.
- After finishing a call, return the handset to its cradle as usual.

Receiving calls using the headset

- Switch to telephone position through the **telephone/computer selection switch (8)**.
- Make sure the headset position is selected on the **headset/handset selection switch (11)**.
- Lift up the handset from its cradle and place it “off-hook”, you should now hear your caller and may speak.
- After finishing a call, return the handset to its cradle as usual.

Using the headset with a computer

- Switch to computer position through the **telephone/computer selection switch (8)**.
- Select the headset position from the **headset/handset selection switch (11)**.
- When a telephone call comes in or you want to make a call while working on your computer, simply switch to telephone position (**8**) and lift the handset.
- When you have finished your call simply place the handset back on its cradle and switch back to computer (**8**) to return to your existing computer work.

BT Accord Helpline

If, after following these instructions and carefully checking the settings, you require assistance with your BT Accord headset please call 0871 200 2276 between 9.00am and 5.30pm Monday to Friday (except public holidays). Calls are charged at national rate.

Troubleshooting

Problem	Items to check
There is no response from the unit	<ul style="list-style-type: none"> • Check if battery power is low and replace all batteries if required • Check if the batteries are inserted correctly • Make sure the on/off is switched to on • Check if the configuration switch is properly selected • Check that the volume control and mute button are adjusted properly • Check that the headset/handset and the cable connecting the BT Accord 30 to the telephone are properly connected
I cannot hear any dial tone or my caller speaking to me	<ul style="list-style-type: none"> • Check if the telephone/computer switch (8) is set to 'telephone' • Re-check your configuration settings (pages 4-5). Try other positions until you can hear a dial tone.
My caller cannot hear me at all or cannot hear me very well	<ul style="list-style-type: none"> • Make sure the mute button is not pressed down • Use the screwdriver to see if the microphone sensitivity (6) is set too low • Try to select the proper settings with the configuration switch
I hear my voice too loud and there is a squealing sound	<ul style="list-style-type: none"> • Use the screwdriver to see if the microphone sensitivity (6) is set too high
When using with my computer, the sound is too loud even though the volume is set at minimum	<ul style="list-style-type: none"> • Take a look at the connection on your computer where the cables connect with the BT Accord 30 amplifier. There should be 3 jacks (line in, line out, and speaker) • Make sure the line out cable from the amplifier is connected to the line in jack of the computer • Make sure that the line in cable from the amplifier is connected to the line out jack of the computer and NOT the speaker jack

Information!

For your safety we advise that you keep this headset and its components away from any liquids. Do not attempt to effect repairs yourself; seek qualified advice. Only use an approved mains adaptor as damage may occur if an incorrect adaptor is used. Always operate at a safe volume level to protect your hearing. Take a break after using the headset for any length of time.

Specifications

Standard operating voltage	3V DC
Operating Current (Max)	9 mA
Standby Current	200 µA
Standby Mode Activation	2 ~ 3 min. without signal
Amplifier Gain - Speaker	13 dB (Max)
- Microphone	30 dB (Max)
Battery	2 x "AA"
Adapter DC input	6V ~ 9V DC
Adapter not included	

Standards Approval



A copy of the Declaration of Conformity for this product can be found at www.easidirect.co.uk

