

DO NOT SCALE FROM THIS PRINT

TMM-1XX-XX-XX-X-SM-XX-X

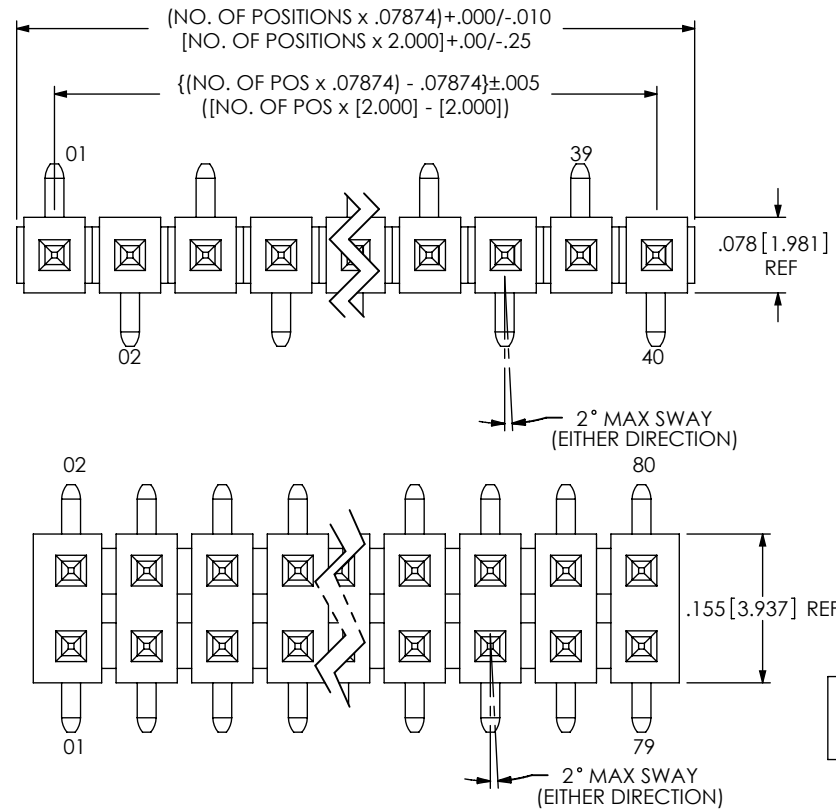

- NO. OF POSITIONS PER ROW
 -02 THRU -40
- TERMINAL SPEC
 -01: USE T-1S13-07-X-2
 -04: USE T-1S13-04-X-2
 -05: USE T-1S13-21-X-2
 -06: USE T-1S13-08-X-2
 (SEE NOTE 8)
- PLATING SPECIFICATION
 -G: GOLD, 30 Au / 50Ni MIN ON CONTACT, 3Au / 50Ni MIN ON TAIL
 -T: MATTE TIN CONTACT AND TAIL
 -S: SELECTIVE, 30 Au / 50Ni MIN ON CONTACT MATTE TIN TAIL
 -L: LIGHT SELECTIVE, 15 Au / 50 Ni MIN ON CONTACT, MATTE TIN TAIL
 -F: FLASH SELECTIVE, 3 Au / 50 Ni MIN ON CONTACT, MATTE TIN TAIL
 -H: HEAVY GOLD, 30 Au / 50Ni MIN ON CONTACT, 3 Au / 50Ni MIN ON TAIL
 -SM: SELECTIVE, 30 Au / 50 Ni MIN ON CONTACT, MATTE TIN TAIL
 -TM: MATTE TIN CONTACT AND TAIL
 -LM: LIGHT SELECTIVE, 15 Au / 50Ni MIN ON CONTACT, MATTE TIN TAIL
 -FM: FLASH SELECTIVE, 3 Au / 50 Ni MIN ON CONTACT, MATTE TIN TAIL
- OPTION
 -P: PICK & PLACE PAD (AVAILABLE ON POSITIONS -03 THRU -40) (SEE SHEET 2, FIG 2)
 -M: METAL PICK & PLACE PAD (SEE SHEET 2, FIG 2) (4 POS. MIN) (-T & -TM PLATING WITH -M OPTION AVAILABLE TO EXISTING CUSTOMERS ONLY AS OF REV.PB. DO NOT DESIGN IN)
 -A: ALIGNMENT PIN (SEE SHEET 2, FIG 3) (5 POS. PER ROW MINIMUM) (NOT AVAILABLE ON SINGLE BODY SPECIFICATION)
 -TR: TAPE & REEL (AVAILABLE ON POS -03 THRU 40) (SEE SHEET 3)
- OPTION
 POLARIZED SPECIFY POS-XX AS POS TO BE OMITTED
- OPTION
 -SM: SURFACE MOUNT
- BODY SPECIFICATION
 -S: SINGLE (TMM-50-S)
 -D: DOUBLE (TMM-50-D)

PATENT NUMBERS
 5713755 / 5961339

TABLE 2

LEAD STYLE	"A" POST	"B" (OAL)	"C"
-01	.126 [3.20]	.302 [7.67]	.100 [2.54]
-04	.075 [1.91]	.255 [6.48]	.100 [2.54]
-05	.065 [1.65]	.323 [8.20]	.080 [2.03]
-06	.168 [4.27]	.476 [12.09]	.100 [2.54]

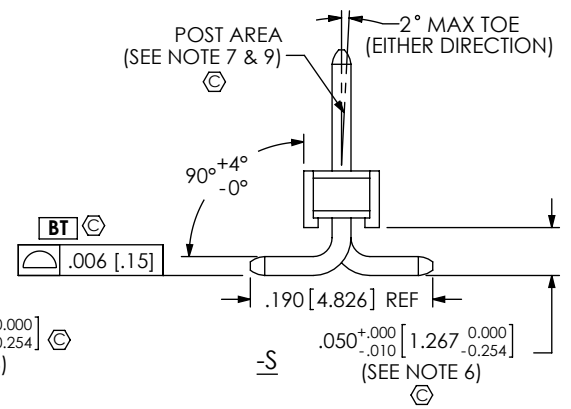
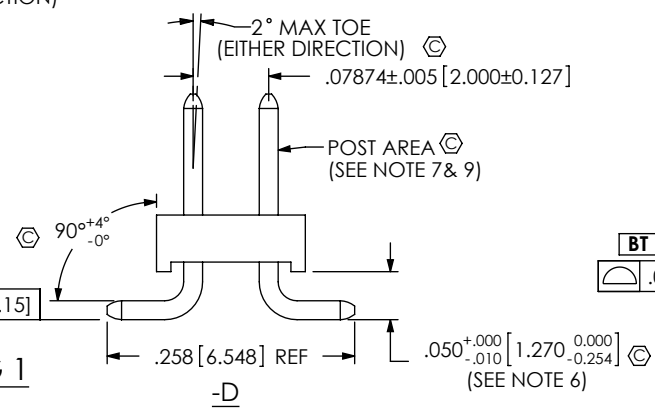
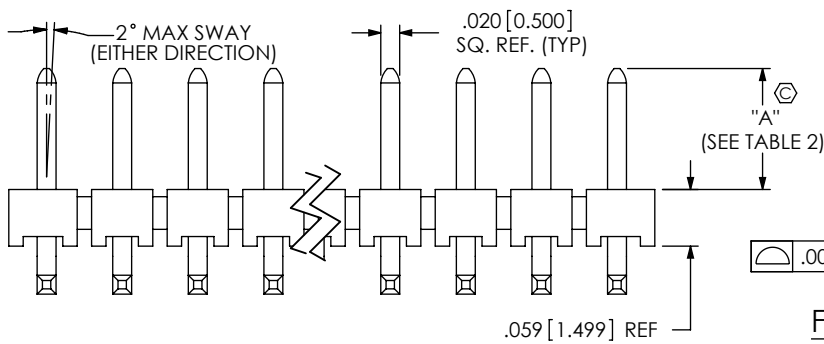

NOTES:

- ⊙ REPRESENTS A CRITICAL DIMENSION.
- MAX. PIN ROTATION IN BODY: 2°
- PUSHOUT FORCE SHALL BE 1 lb MIN.
- ALL DIMENSIONS IN BRACKETS [] TO BE MILLIMETERS.
- PACKAGE POSITIONS 03-40 IN TUBES; LAYER PACKAGE -02 POSITION.
- .050 [1.27] DIMS TO BE CHECKED AT BEND RADIUS, NOT AT END OF PIN
- PINS TO BE INSERTED TAIL SIDE FIRST TO AVOID SCRATCHES ON CONTACT
- SHEAR TAILS FOR -05 & -06 LEAD STYLE
- NO BANDOLIER MARKS ARE ALLOWED IN THE POST AREA.
- MAX. CUT FLASH: .010 [0.25]

UNLESS OTHERWISE SPECIFIED, DIMENSIONS ARE IN INCHES. TOLERANCES ARE: DECIMALS ANGLES .XX: ±.01 2° .XXX: ±.005 .XXXX: ±.0020	PROPRIETARY NOTE THIS DOCUMENT CONTAINS INFORMATION CONFIDENTIAL AND PROPRIETARY TO SAMTEC, INC. AND SHALL NOT BE REPRODUCED OR TRANSFERRED TO OTHER DOCUMENTS OR DISCLOSED TO OTHERS OR USED FOR ANY PURPOSE OTHER THAN THAT WHICH IT WAS OBTAINED WITHOUT THE EXPRESSED WRITTEN CONSENT OF SAMTEC, INC.		
		520 PARK EAST BLVD., NEW ALBANY, IN 47150 PHONE: 812-944-6733 FAX: 812-948-5047 e-Mail: info@SAMTEC.com code 53322	
DO NOT SCALE DRAWING SHEET SCALE: 4:1		DESCRIPTION: 2MM TERMINAL STRIP ASSEMBLY	
MATERIAL BODIES: LCP UL 94 VO, COLOR BLACK TERMINALS: PHOSPHOR BRONZE		DWG. NO. TMM-1XX-XX-XX-X-SM-XX-X	
F:\DWG\MISC\MKTG\TMM-1XX-XX-XX-X-SM-XX-X-MKT.SLDDRW		BY: REIDINGER 05-22-1991 SHEET 1 OF 3	

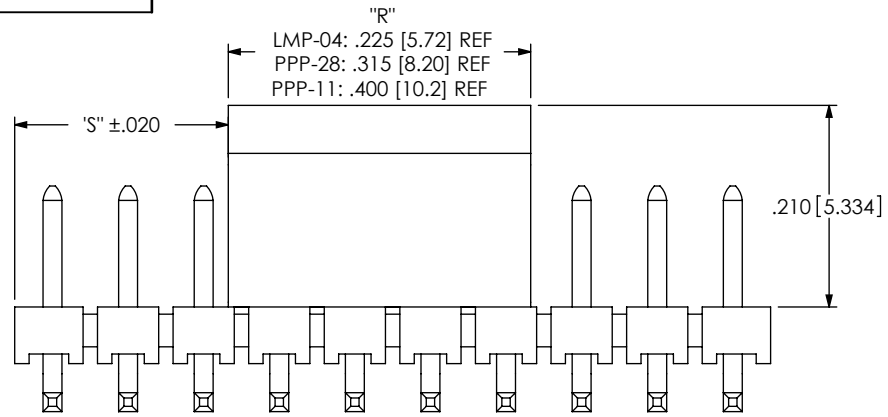

"R" = PAD SIZE ABOVE
 "S" = ((NO OF POS x 07874) - "R")/2

-P: PICK & PLACE PAD

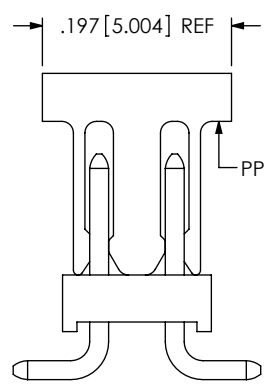

DOUBLE
FIG 2

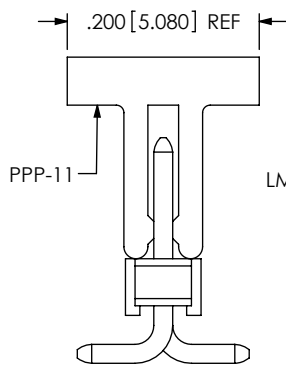

SINGLE

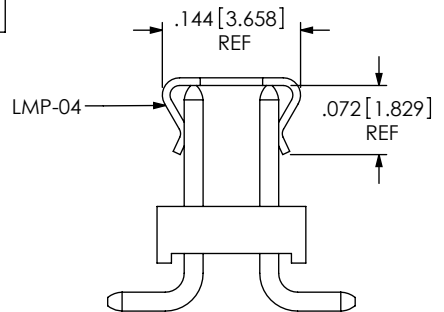

-M: PICK & PLACE PAD
DOUBLE ONLY

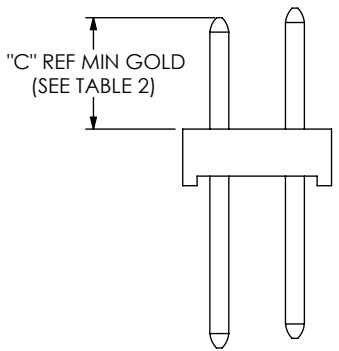

-D

IN-PROCESS 1

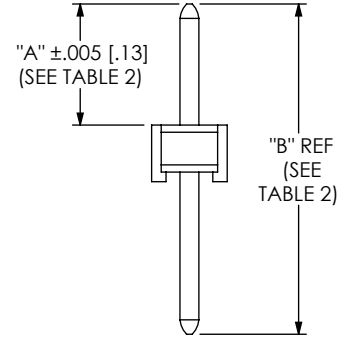

-S

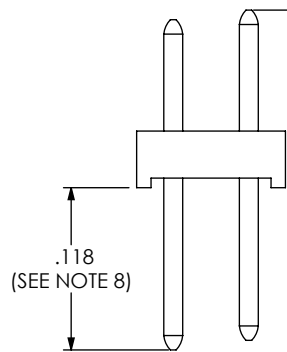

-D

IN-PROCESS 2
-05 & -06 LEAD STYLE ONLY

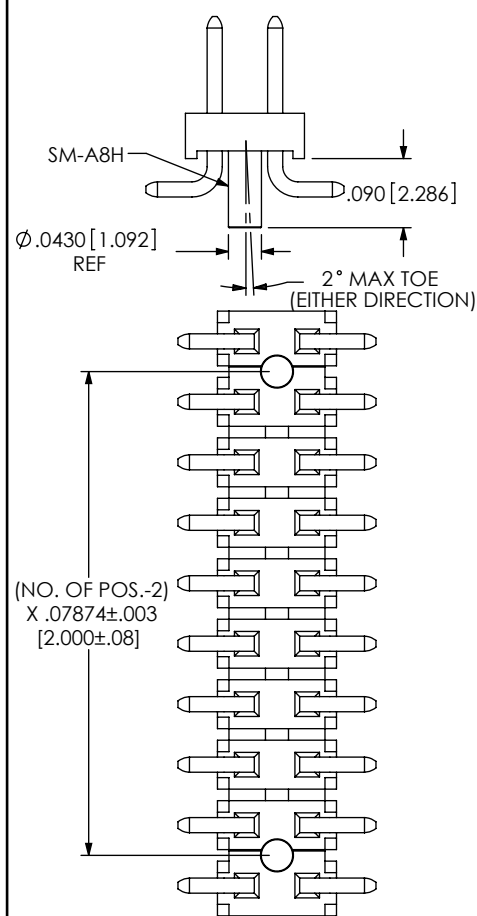

(NO. OF POS.-2)
X .07874±.003
[2.000±.08]

FIG 3
-A: ALIGNMENT PIN
(5 POS. PER ROW MINIMUM)

F:\DWG\MISC\MKTG\TMM-1XX-XX-XX-X-SM-XX-X-MKT.SLDDRW

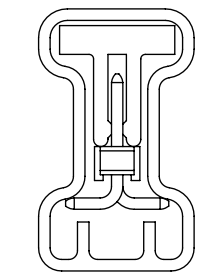

PT-1-24-01-17
TMM-1XX-XX-X-X-SM-S
TMM-1XX-XX-X-X-SM-S-P

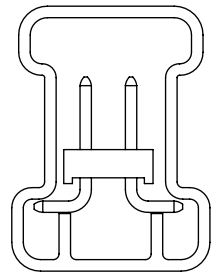

PT-1-24-02-17
TMM-1XX-XX-X-X-SM-D

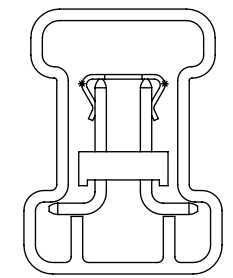

PT-1-24-02-17
TMM-1XX-XX-X-X-SM-D-M

TUBE VIEW

TABLE 1 (SEE NOTE 5)		
OPTION	PKG TUBE	PLUG
-S, -S-P	PT-1-24-01-17	TP-24
-D, -D-A, -D-M, -D-A-M, -D-P, D-A-P	PT-1-24-02-17	TP-09

PROPRIETARY NOTE
 THIS DOCUMENT CONTAINS INFORMATION CONFIDENTIAL AND PROPRIETARY TO SAMTEC, INC. AND SHALL NOT BE REPRODUCED OR TRANSFERRED TO OTHER DOCUMENTS OR DISCLOSED TO OTHERS OR USED FOR ANY PURPOSE OTHER THAN THAT WHICH IT WAS OBTAINED WITHOUT THE EXPRESSED WRITTEN CONSENT OF SAMTEC, INC.

DO NOT SCALE DRAWING

SHEET SCALE: 4:1



520 PARK EAST BLVD, NEW ALBANY, IN 47150
 PHONE: 812-944-6733 FAX: 812-948-5047
 e-Mail info@SAMTEC.com code 55322

DESCRIPTION:
2MM TERMINAL STRIP ASSEMBLY

DWG. NO.
TMM-1XX-XX-XX-X-SM-XX-X

BY: REIDINGER 05-22-1991 SHEET 2 OF 3

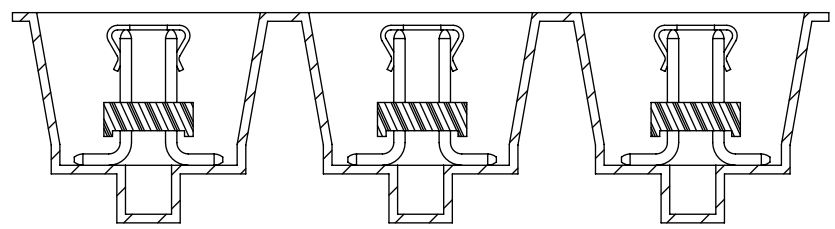
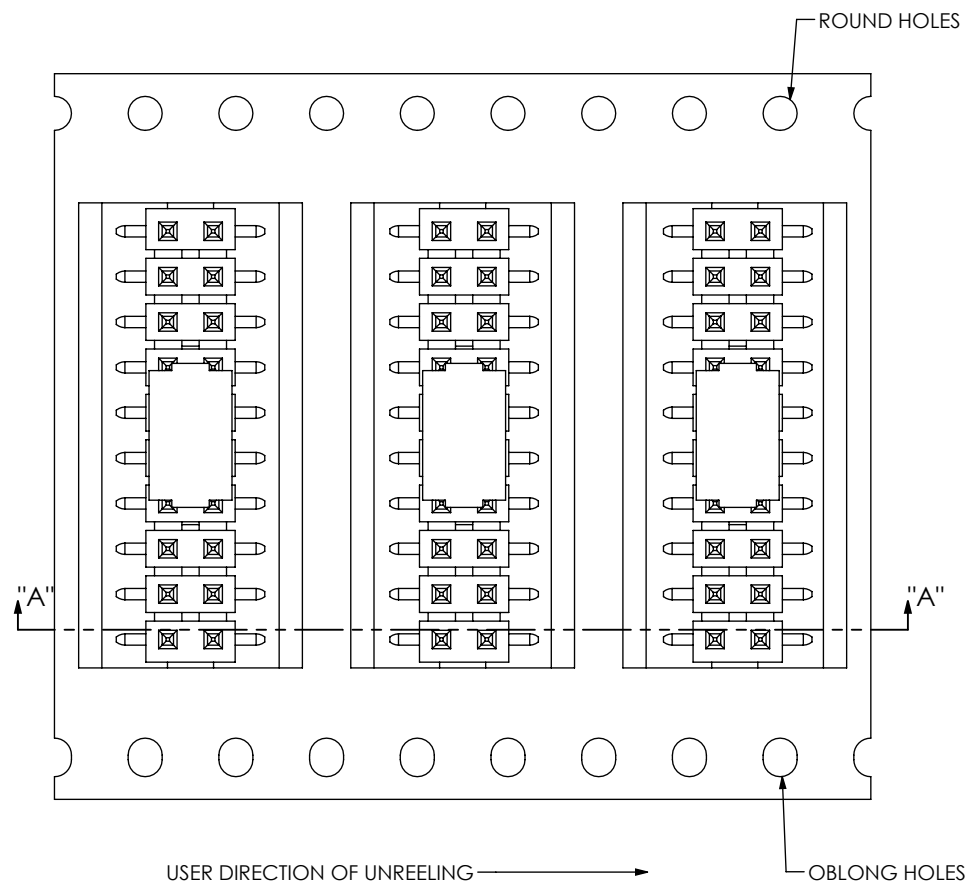

TAPE AND REEL VIEW

PROPRIETARY NOTE
 THIS DOCUMENT CONTAINS INFORMATION CONFIDENTIAL AND PROPRIETARY TO SAMTEC, INC. AND SHALL NOT BE REPRODUCED OR TRANSFERRED TO OTHER DOCUMENTS OR DISCLOSED TO OTHERS OR USED FOR ANY PURPOSE OTHER THAN THAT WHICH IT WAS OBTAINED WITHOUT THE EXPRESSED WRITTEN CONSENT OF SAMTEC, INC.

DO NOT SCALE DRAWING

SHEET SCALE: 1:1

	
520 PARK EAST BLVD, NEW ALBANY, IN 47150 PHONE: 812-944-6733 FAX: 812-948-5047 e-Mail: info@SAMTEC.com code 55322	
DESCRIPTION:	
2MM TERMINAL STRIP ASSEMBLY	
DWG. NO.	
TMM-1XX-XX-XX-X-SM-XX-X	
BY: REIDINGER 05-22-1991	SHEET 3 OF 3