

# Chapter 1 Quick Start

---

## Contents

- Feature information for the experienced LAN cable tester
- Quick steps for tester calibration, setup, test modes, and operation

## What's in the Box?

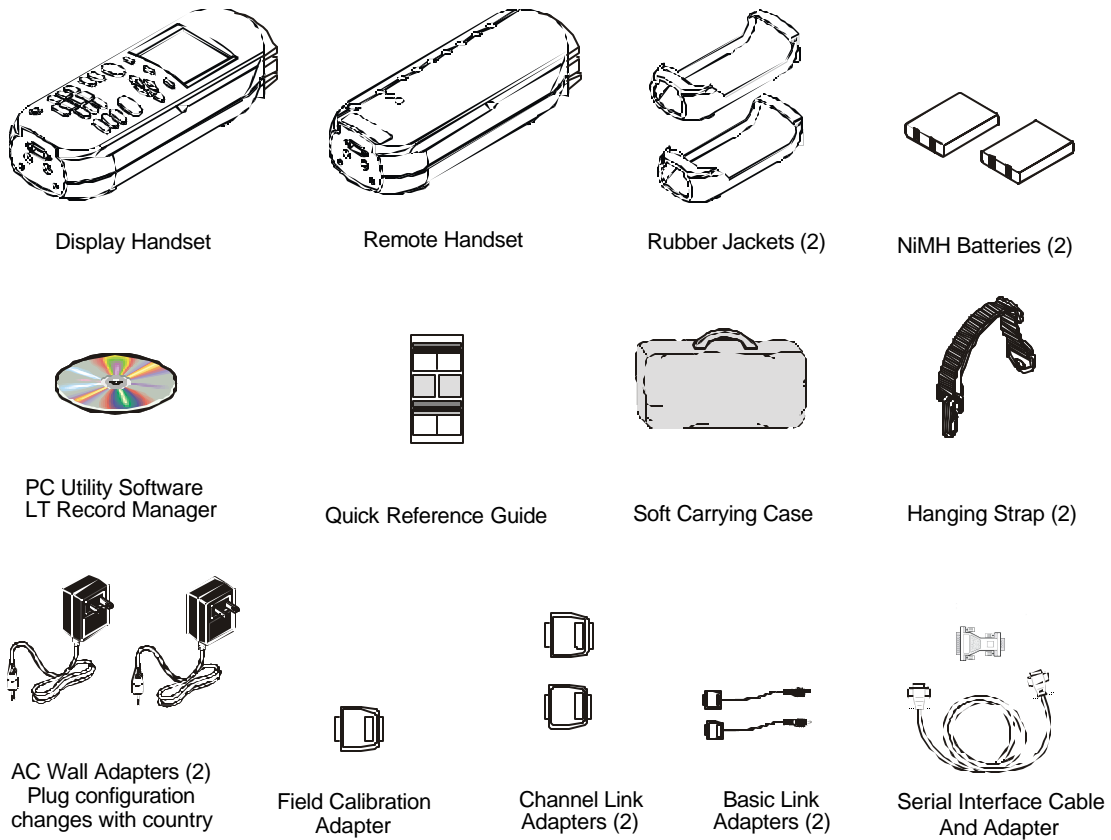

**Figure 1-1: Contents of Package**

## LT 8000 Series Tester Comparisons

	<b>LT 8100</b>	<b>LT 8155</b>	<b>LT 8600</b>
Frequency Test Range	100 MHz	155 MHz	300 MHz
Highest Level of Standards Category Compliance	CAT 5E, Class D	CAT 5E, Class D with Headroom	CAT 6, Class E with Headroom
Accuracy	Level IIE	Level IIE	Level III
Number of Test Records Stored	150	1500	1500
Upgradeable to Next Higher Level Tester	Yes	Yes	N/A
Protective Rubber Boot on Both Handsets	Yes	Yes	Yes
Built-In Tone Generator	Yes	Yes	Yes
Talkset Capability	Yes	Yes	Yes
LT Record Manager Software Program Included	Yes	Yes	Yes
Use with Additional Remote Handset	No	Yes	Yes
Fiber Optic Cable Testing Capability	No	Yes	Yes
Soft Carrying Case Included	Yes	Yes	Yes
Basic Link Adapter	Yes	Yes	Yes
Channel Link Adapter	Optional	Yes	Yes

### LT 8000 Series Tester Options and Accessories

	<b>LT 8100</b>	<b>LT 8155</b>	<b>LT 8600</b>
Deluxe Hard Shell Carrying Case	Yes	Yes	Yes
110-Block Adapter Set	Yes	Yes	Yes
Token Ring Adapter Set	Yes	Yes	Yes
COAX Adapter Kit	Yes	Yes	Yes
Dual-Bay, Battery Quick Charger	Yes	Yes	Yes
Spare/Replacement Battery	Yes	Yes	Yes
Fiber Optic Cable Testing Capability	Yes	Yes	Yes

## Quick Start Procedures

The objective of this section is to supply a *highly experienced cable installer* with enough information to perform an Autotest on a twisted pair cable.

### Power-up

Power up the Display Handset by pressing the **On/Off** key.

*Note: The Remote Handset will be powered up automatically by the Display Handset when the test begins.*

### Self-Test

When the LT 8000 Series Tester is turned on, it displays a *Self-Test In Progress* message and performs a quick self-test. An alert message is displayed if the self-test determines that calibration or repair is necessary.

### Tester Calibration

A calibration screen will always appear 24 hours after the last field calibration. To recalibrate the tester perform the following steps:

1. Connect the DH and RH end-to-end using the Field Calibration Adapter.
2. From the DH **Tools** screen, select the **Field Calibration** icon.
3. Press the **Tone Key** on the RH. The unit turns on and indicates a test is running.
4. Select the **Run** option on the DH.

If the calibration was successful, remove the Field Calibration Adapter and proceed to the next section.

If the calibration was unsuccessful, proceed to *Chapter 3, Tester Field Calibration*. If you are unable to fix the problem, contact your local distributor or a Wavetek service facility for assistance.

## Twisted Pair Cable Connections

Most Autotests are performed with the DH and RH connected at opposite ends of the cable under test. The minimum level of connectivity required depends on the test and cable type selected.

- Some tests can be performed *without* the RH. Stored test results or test printouts will indicate the presence or absence of the RH during the test.
- If the test requires the RH, the DH will first attempt to communicate with the RH. If unable to communicate, the DH will display a message that it is looking for the RH.

Observe the following cautions while connecting the tester.

### Shielded Cabling Systems



Do not create testing ground loops with shielded cable systems. Shielded cable systems (i.e., Token Ring, 4 pair STP, or Coaxial) present a unique testing problem due to the cable shield's ground connection. The LT 8000 Series units can test these systems to specifications only if the handsets are operated on battery power and not connected to a PC or printer using a copper serial cable.

If connection to a printer or PC is essential to perform testing, Wavetek recommends using battery operated devices and removing any wall power charging inputs. If this is not possible, an optically isolated serial cable should be used during testing to isolate the tester from all other ground connections.

### **TELCO Lines**



Do not connect the tester to live/active TELCO lines. If you accidentally plug the unit into outlets with active TELCO present (indicated by a “Voltage Exceeds Limits” warning message) disconnect the tester immediately.

### **Basic Link Test Setup**

1. Attach the Basic Link Adapters to both the Display and Remote Handsets.
2. On the horizontal network cable to be tested, disconnect the corresponding user patch cords from the network patch panel and the RJ-45 wall outlet.
3. Connect the DH Basic Link Adapter to the network patch panel, and the RH Basic Link Adapter to the wall outlet.

*Note: Don't forget to change the Cable Type to Basic Link*

### **Channel Link Test Setup**

1. Attach the Channel Link Adapters to both the Display and Remote Handsets.
2. On the horizontal network cable to be tested, disconnect the corresponding user patch cords from the network equipment.
3. Connect the DH Channel Link Adapter to the network patch panel user patch cord, and the RH Channel Link Adapter to the wall outlet user patch cord.

*Note: Don't forget to change the Cable Type to Channel Link*

## Set Autotest Preferences

Autotest is the most frequently used test mode. A number of preferences can be selected for the Autotest function. The tester can be set to:



- Stop on a test failure
- Automatically save test results
- Automatically increment test names
- Display graphs of passed tests

To set Preferences:

1. Open the Autotest **Preferences** screen. Set preferences as required (refer to *Chapter 3, Set Autotest Preferences*).

## Perform Autotest on a Twisted Pair Cable

The selection of cable type determines the default tests included in an Autotest suite.

1. Select the **Cable Type** (refer to *Chapter 3, Selecting Cable Type*).
2. Press the **Autotest**  key to begin testing. The cable tester will perform a predefined test suite.
3. The test result is displayed below the Title Bar at the top right corner. A boxed checkmark  indicates an overall pass.
4. To interpret, save, or print an Autotest result, refer to *Chapter 5, Autotesting*.

## **Next Steps**

Refer to the following chapters for more information regarding the setup and operation of the LT 8000 Series tester.

### **Chapter 2 Your WWG Cable Tester**

This chapter describes the LT 8000 Series controls, indicators, and screens. It also contains information regarding tester power management.

### **Chapter 3 Self-Tests, Calibration, and Configuration**

This chapter also explains how to run and interpret Self-Tests, respond to Warning screens, calibrate and configure the tester, and use the Tone Generator and Audio Talk Set.

### **Chapter 4 LT 8000 Cable Testing Fundamentals**

This chapter describes physical and electrical characteristics of cables, test descriptions, and test storage and data management procedures. This chapter also describes how to set up different cabling tests, what to do when tests fail, and typical causes of test failure.

### **Chapter 5 Autotesting**

This chapter describes the Autotest function, and provides instructions for setting up test preferences. This chapter also describes individual tests that run during an Autotest, and provides instructions for viewing and interpreting Autotest results.

## **Chapter 6 Analyze Testing**

This chapter describes the Analyze test function, and provides instructions for setting up test preferences and running an Analyze test. This chapter also provides instructions for viewing and interpreting test results.

## **Chapter 7 Using LT Record Manager Software**

This chapter describes how to upload test data from the LT 8000 Series tester to an IBM-compatible PC, and how to organize and print the test data.



# Chapter 2

## Your WWG Cable Tester

---

### Contents

- Tester controls and indicators
- Tester Ready screen
- Useful information about power management

### The Display Handset

The LT 8000 Series testers are high-performance, portable LAN cable testers designed to test and measure twisted pair and coaxial cable used for high speed data communications networks.

### The Display Handset

Figure 2-1 shows the controls and indicators of the Display Handset (DH). Table 2-1 provides a brief description of each DH feature.

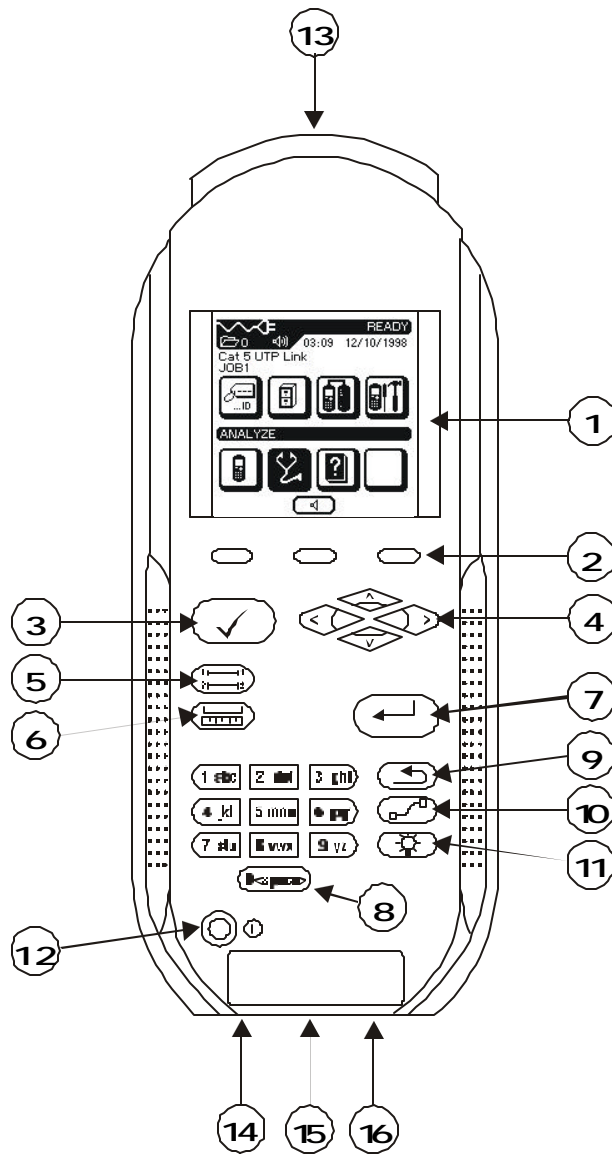

Figure 2-1: Display Handset Front Panel

**Table 2-1: Display Handset (DH) Front Panel**

<b>Callout</b>	<b>DH Front Panel</b>	<b>Description</b>
1	Graphical Display	Present menus, test results, graphs, action choices and option keys.
2	Option Keys	Select menu options displayed on screen.
3	Autotest Key	Perform a fast suite of tests. Test results are presented as pass/fail. Suites for established standards are preprogrammed in the tester.
4	Arrow Keys	Allow up, down, left, and right movement on the display.
5	Wiremap Key	Find shorts, opens and miswires such as split and reversed pairs.
6	Length Key	Initiate a Length test.
7	Enter Key	Select a highlighted option. Save changes.
8	Alphanumeric Keys	Enter numbers, letters or special characters. Select numbered menu options.
9	Escape Key	Abort and exit the current screen without making changes.
10	Cable Selection Key	Select a cable type.
11	Backlight Key	Toggle the screen backlight on/off.
12	On/Off Switch	Power the Display Handset on/off.
13	Low-Crosstalk Connector Port	Connect a test access cable.
14	Talkset Jack	Connect an Optional Talkset
15	DB-9 Serial Port	Printer and PC upload port. Also used to load software upgrades.
16	DC Input Jack	Connect an external power supply.

## Ready Screen

The Ready screen appears when the unit is powered up (if the unit has been calibrated within 24 hours) or after field calibration.

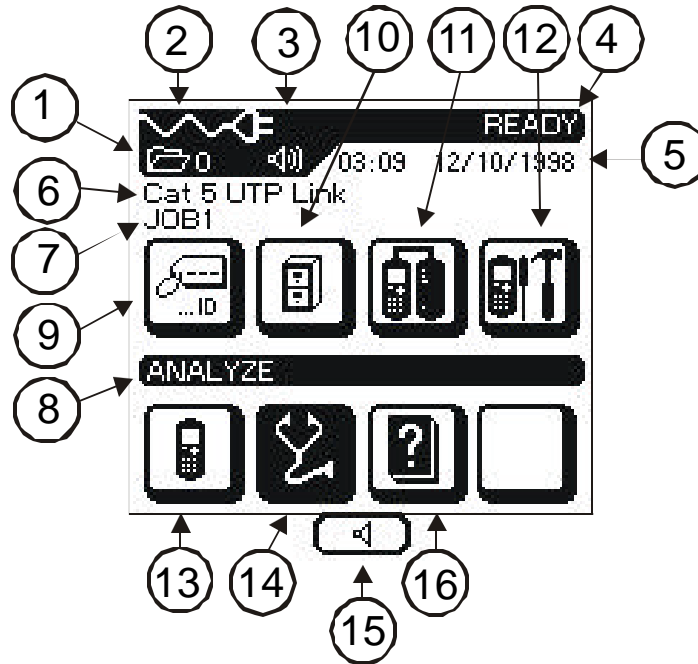

Figure 2-2: Ready Screen

**Table 2-2: Ready Screen Indicators**

<b>Indicator</b>	<b>Function</b>	<b>Description</b>
1	Memory Usage	Display the total number of records stored.
2	Battery Meter	Display remaining battery power level (from Empty to Full).
	AC Cable	Indicate when the unit is running off AC power.
3	Talk Set Indicator	Indicate when the Talk Set function is available.
4	Screen Title	Display the Screen Title.
5	Time and Date	Display time and date information.
6	Setting	Display the cable type selected for testing.
7	Label	Display the current job name.
8	Label	Display the screen title for the highlighted function.

**Table 2-3: Ready Screen Functions**

<b>Icon</b>	<b>Function</b>	<b>Purpose</b>
9	Cable ID	Select the cable naming function.
10	Test Record	Select the stored test file manager.
11	Field Calibration	Select the field calibration screens.
12	Preferences	Select the instrument preferences screen.



*(Table Continues)*

Table 2-3: Ready Screen Functions (Continued)

Icon	Function	Purpose
13	Instrument Information	Select the instrument information screen.
14	Analyze	Select option to perform individual cable tests (real time).
15	Talk Set Select	Activate/deactivate the Talk set function
16	Help	Select the Information Screen.







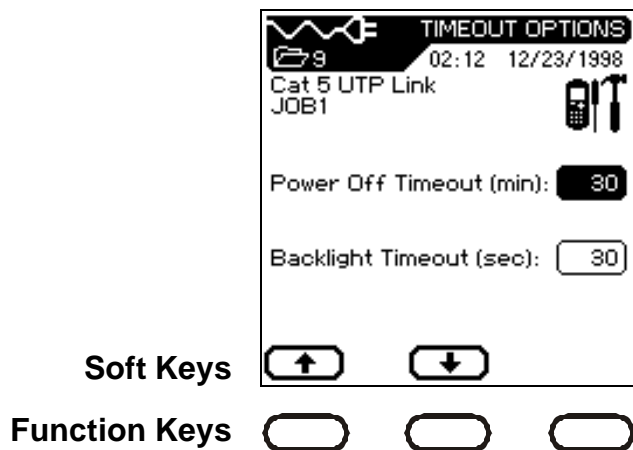





## Soft Keys

User options will often appear at the bottom of the tester display screen. These action items (soft keys) are positioned over the three function keys directly below the display screen. To select an action item, press its corresponding function key.

In the example below, you would press the **Function** keys directly below  or  to adjust the Timeout options.



**Table 2-4: Soft Key Descriptions**

Soft Key	Description
	Okay or confirm an action.
	Stop or cancel an action.
	Print data.
	Save data using Auto Increment naming convention.
	Overwrite or rename data.
	Run the selected test in continuous mode (real time).
	Page-up for information.
	Page-down for information.
	Select/Deselect an item in a list box. <ul style="list-style-type: none"> <li>• Check boxes are on-off switches.</li> <li>• If a check box is turned on, the box will contain a check mark.</li> </ul>
	Select an action item.
	Activate/Deactivate the Talk Set option.
	Delete characters.

## Display Handset Interface Ports

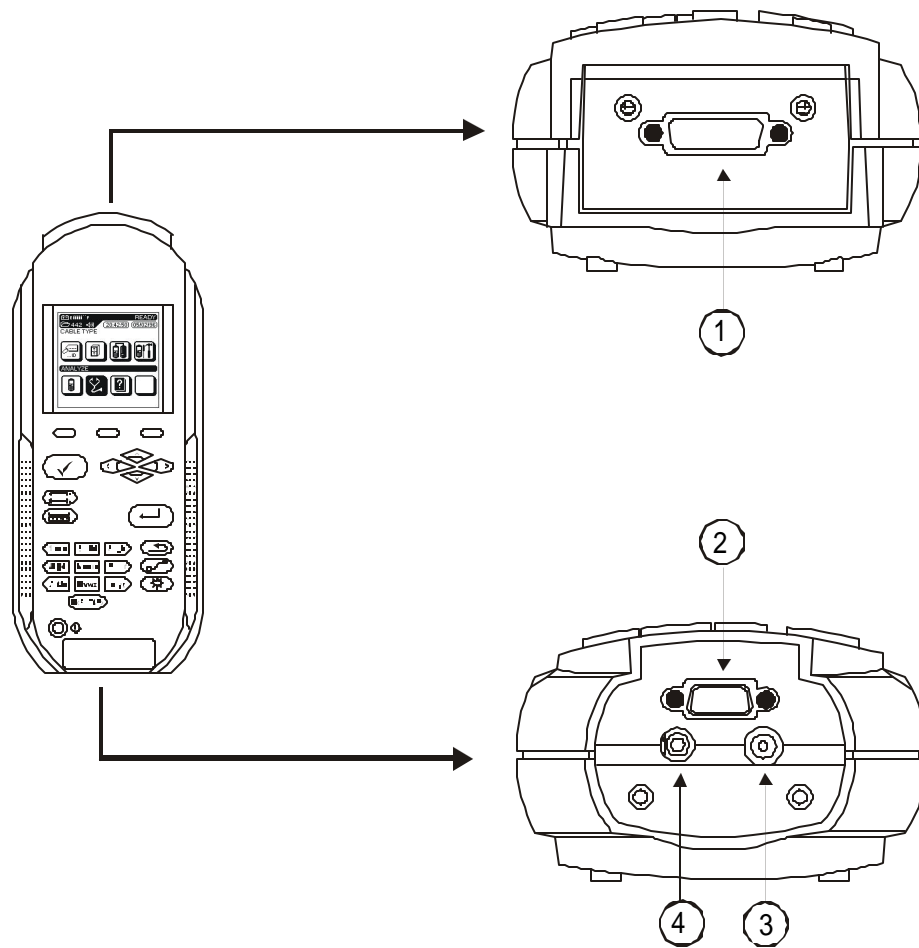

Figure 2-3: Display Handset Interface ports

**Table 2-5: DH Connectors**

<b>Callout</b>	<b>Connector</b>	<b>Description</b>
1	Low-Crosstalk Connector	Attach adapters for all types of cables.
2	DB-9 Serial Port	Supports the following functions: <ul style="list-style-type: none"><li>• Print test results on a serial printer.</li><li>• Upload stored test results to a PC.</li><li>• Load firmware upgrades.</li></ul>
3	DC Input Jack	Used to charge the battery in the handset.
4	Talkset Jack	Used to connect the optional Talkset to the tester.

## **Connecting to a Printer**

Test results can be printed during Autotest, Fault Find or from memory using a serial printer. The testers are compatible with any serial printer that conforms to Epson or ASCII serial printer commands.

**To connect a printer:**

1. Connect the tester to the printer serial port.
2. Make sure the printer is powered up and on-line.
3. The tester default baud rate is 38400 (57600 for the LT 8600). The LT 8600 is capable of supporting up to 115,000. Determine the printer baud rate, handshake (XON/XOFF is ON or OFF), and change the defaults using the Preferences screen. Refer to *Chapter 3, Self-Tests, Calibration, and Configuration* for setup information.

**Table 2-6: Serial Port Pin Assignments**

<b>Pin</b>	<b>DTE Mode</b>	<b>DCE Mode</b>
1	Data Carrier Detect	Data Carrier Detect
2	Transmit	Receive
3	Receive	Transmit
4	Data Terminal Ready	Data Terminal Ready
5	Ground	Ground
6	Data Set Ready	Data Set Ready
7	Ready To Send	Ready To Send
8	Clear To Send	Clear To Send
9	Not Connected	Not Connected
S	Shield	Shield

*Note: DTE - DCE is selectable in the Setup menu, however DTE is the Default Mode.*

**Table 2-7: Required PC Setting for Serial Port Data Stream**

<b>Parameter</b>	<b>Setting</b>
Data Length	8 bits, no parity
Start/Stop bit	1/1
Speed	1200 to 38,400 baud rate (LT 8100 & LT 8155), 1200 to 115,000 baud rate (LT 8600) user selectable
Control	CTS

## The Remote Handset

The RH (Remote Handset) works with the DH (Display Handset) to perform Autotest or individual real time Analyze tests. The RH terminates the cable link and communicates with the DH. The RH is automatically activated by the DH and does not have a separate power-on key. The RH does need to have power available when performing a field calibration, otherwise, the DH will not find it.

Figure 2.4 shows the controls and indicators of the Remote Handset (RH). Table 2-8 provides a brief description of each RH feature.

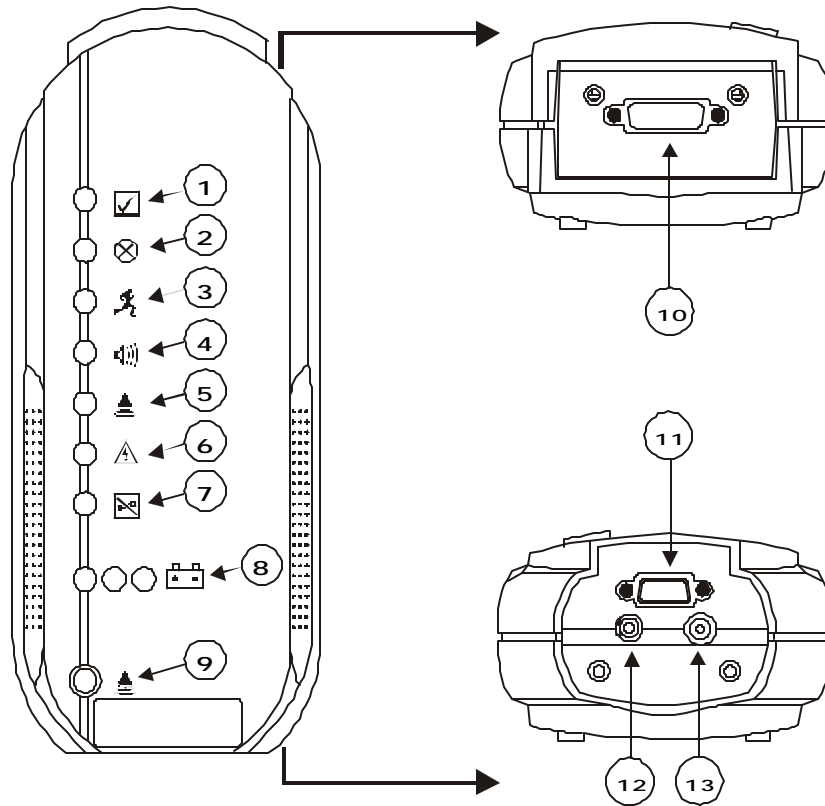

Figure 2-4: Remote Handset

**Table 2-8: RH Buttons, LED's, and Connectors**

<b>Callout</b>	<b>RH Front Panel</b>	<b>Description</b>
1	Pass LED	Successful test results
2	Fail LED	Unsuccessful test results
3	Testing LED	Test in progress
4	Talkset LED	Talkset is active
5	Tone LED	Toner is in operation
6	High Voltage LED	Excessive line voltage present (TELCO)
7	No Patch Cable LED	No patch cable connected
8	Battery Level LED's	Remaining battery life
9	Tone switch	Press to activate/deactivate Toner
10	Low-Crosstalk Connector Port	A test access cable connector
11	DB-9 Serial Port	Use to interface to a PC
12	Talkset Jack	Connect an Optional Talkset
13	DC Input Jack	Connect an external power supply

### **Operational sequence:**

- The DH searches for the RH.
- During *testing*, if the two handsets are unable to communicate, the DH will display a message that it is searching for the RH and continue trying to establish communications until you manually cancel the operation or the RH is found. If the handsets are unable to establish communication, check the links to verify proper connection.
- During *field calibration*, if the two handsets are unable to communicate, the DH will display a message instructing you to connect the DH and RH together using the calibration adapter. If you attempt to run the test without the adapter, the DH will display a warning message.
- After a brief period of inactivity, the RH automatically powers down to save battery power.

### **Battery and Power Management**

Both the Display and Remote Handsets use interchangeable, rechargeable NiMH (Nickel Metal-Hydride) battery packs.

- The DH (Display Handset) can be run on battery power for approximately eight hours. Actual battery power times will vary because of factors such as the tester model, operating time versus standby time, use of the display backlight, and temperature.
- When the battery is almost empty, the tester displays a warning message. The tester will automatically shut down before testing results are affected.
- The RH (Remote Handset) can be run on battery power for approximately ten hours.

## Operating the DH and RH from an AC Power Source

The DH and RH handsets can be operated from an external DC source (Wall Cube).

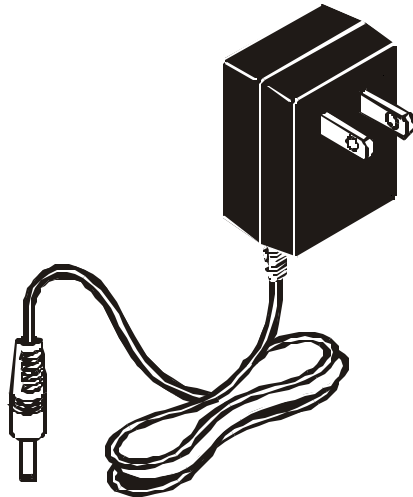

**Figure 2-5: Tester AC Adapter**

When the AC Wall Cube Adapter is used to power the handsets:

- Both handset batteries will receive a trickle charge.
- The DH handset will display the AC plug and cable indicator at the top left of the screen.
- All three RH battery power LEDs will illuminate when the unit is activated by the DH.



Only the Power Cube provided with the instrument should be used. Other types of Power Cubes may cause damage to the tester.

## **Battery Charging**

The handset batteries are recharged using the AC Wall Cube. The DH uses battery powered flash ROM to store handset data and settings whenever the battery is removed from the tester. The internal flash ROM battery has a three year life expectancy.

### **Using the AC Wall Cube Adapters:**

- The batteries can be recharged in the handsets (using the AC Wall Cube) in about 8 hours.

# Chapter 3

## **Self Tests, Calibration, and Configuration**

---

### **Contents**

- Running and interpreting Self Tests
- Responding to Warning screens
- Calibrating and configuring the tester
- Using the Tone Generator and the Audio Talk Set
- Creating and using custom cable settings

### **Self-Test Screen**

If you suspect a problem, self tests can be used to evaluate tester performance. The following self test options are available:

- Instrument
- Keyboard
- RS232 Interface

**To run a self test:**

1. In the Tools screen, select the Instrument  icon and press **Enter**  to open the Instrument screen.

The Instrument screen will list a set of user options that can be performed by the tester.

2. Use the **Arrow** keys to position the cursor bar on the **Self Test** option.



3. Press  to open the Self Test screen.

4. Use the **Arrow** keys to position the cursor bar on the desired **Self Test** option.



In this example, press the **Down Arrow** key once to select **Keyboard**.



5. Press **Enter**  to start the Keyboard Test.

The Keyboard Test screen displays.







6. While the Keyboard Test is running, press suspected bad key(s) and observe the display screen for a response.
7. When you are finished testing, press  to return to the Self Test screen.
8. For some tests, the **Stop/Cancel**  button will end the test in progress.

## Self Test Screens

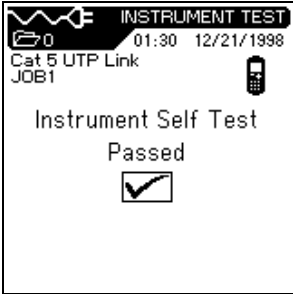
The Self Test screens allow you to monitor the progress and results of each test. Refer to the following table for a brief description of self test screens.

**Table 3-1: Self Test Screens**

Test	Screen	Description
Instrument	 <p>The screenshot shows the 'INSTRUMENT TEST' screen with a checkmark icon and the text 'Instrument Self Test Passed'.</p>	<p> The instrument self test was successful.</p> <p> The instrument self test has failed.</p> <p>Press the <b>Run</b>  key and proceed to the next error, if there has been more than one error.</p>
Keyboard	 <p>The screenshot shows the 'KEYBOARD TEST' screen with the text 'Keyboard Test Press Key' and 'Key:'.</p>	<p>The instrument is performing a keyboard self test.</p>

*(Table Continues)*

**Chapter 3**  
**Self Tests, Calibration, and Configuration**

---



**Table 3-1: Self Test Screens (Continued)**

<b>Test</b>	<b>Screen</b>	<b>Description</b>
RS232 Serial Interface	 <p>The image shows a handset screen with the following text: 'RS232 I/F TEST' at the top right, '15:39 10/21/1998' for time and date, 'CABLE TYPE' and 'JOB NAME' with a handset icon to the right, 'RS232 I/F Test' in large font, 'Transmitting Test Message to Communication / Printer Port.' in smaller font, and configuration details: 'Baud: 9600 Mode: DTE', 'Data bits: 8 Parity: NONE', and 'Stop Bits: 1'. A small handset icon is also visible at the bottom right of the screen.</p>	The handset is transmitting a test message to the RS232 printer port.

## Warning Screens

In response to a failure, harmful condition, or operational limitation, the tester will often display a warning screen.

**Table 3-2: Warning Screens**

Warning	Screen	Description
Memory Is Almost Full		<p>Tester memory is 80% full.</p> <p>You must upload or delete data to stop this message from appearing.</p>
Memory Is Full		<p>A save operation has filled the tester's memory.</p> <p>You must upload or delete data to stop this message from appearing.</p>
No Cable Present		<p>An operation requiring a cable type has been attempted without first connecting a patch cable to the unit.</p>

*(Table Continues)*

**Table 3-2: Warning Screens (Continued)**

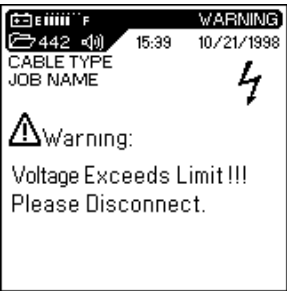
Warning	Screen	Description
Low Battery		<p>Handset battery voltage is low.</p> <p>This screen will continue to appear every time a Hard key is pressed or when you return to the Tools screen.</p> <p>Replace or recharge the battery to turn off this warning screen.</p>
Input Voltage Exceeds Limits		<p>High voltage has been detected on the connector pins.</p> <p>The warning message will stay on until the high voltage is removed.</p>

## Tester Field Calibration

All LT 8000 Series testers require field calibration every 24 hours. A calibration reminder message will appear on the display handset screen when calibration is required.

Before performing field calibration, connect the Display and Remote Handsets together using the calibration connectors as shown below. Turn on the power to both the DH and RH before performing unit calibration.

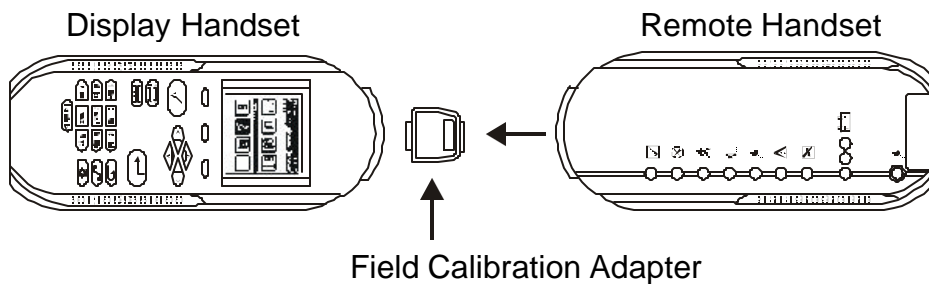



Figure 3-1: Tester Field Calibration Setup

### To calibrate the tester:

1. From the Tools screen, select the **Field Calibration**  Icon. The Calibration screen appears.

Activate the remote handset by pressing the **Tone Key**.



2. Press  to begin the calibration process. Calibration takes approximately one minute.

### Chapter 3 Self Tests, Calibration, and Configuration

---

3. If calibration is successful, a **Calibration Complete**  symbol appears.
4. After a brief period, the tester returns to the **Ready** screen.

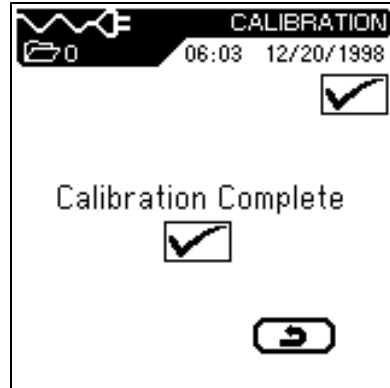

5. If calibration is unsuccessful, the tester will briefly display one of the following Error screens.

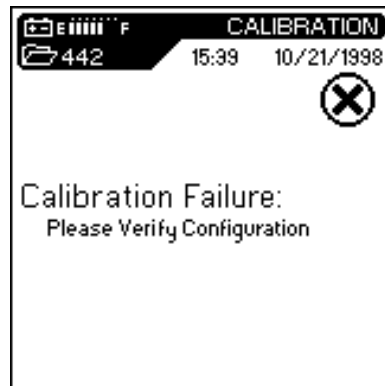

6. The tester display returns to the **Ready** screen upon exit from a calibration error screen.

*Note: An Autotest failure will occur if the field calibration is out of date.*

**Table 3-3: Unsuccessful Field Calibration Checklist:**

<b>Action</b>	<b>Result</b>
Check the battery power on both the Display and Remote Handsets.	Check the DH for a low battery message. If the Display Handset indicates a low battery, you must recharge the battery before the unit will pass calibration.  The RH will not respond if its battery is low.
Check the calibration adapter.	Make sure the adapter is correctly seated and that there are no bent pins.

If you are unable to successfully calibrate the tester, contact your local distributor or a WWG service facility for assistance.

## Tester Configuration

Most tester configuration parameters are set from the Preferences screen.

### To open the Preferences screen:

1. From the Ready screen, select the **Instrument**  Icon. The Preferences screen displays.

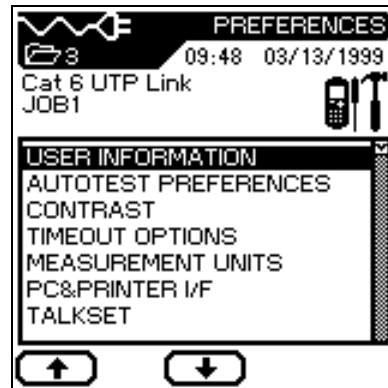

2. Use the **Arrow** keys to select one of the following options:
  - Enter User Information
  - Set Autotest Preferences
  - Adjust Display Contrast
  - Set Time-out Options
  - Set Measurement Units
  - Configure the PC & Printer I/F
  - Configure the Talkset Option
  - Set Date & Time
  - Select Display Language
  - Restore Factory Defaults
  - Clear Memory

## Entering User Information

User information identifies the unit operator for test reports.

1. From the Preferences screen, select the **User Information** option. The User Information screen displays.



2. Use the **Alphanumeric** keys to enter your name.
3. Use the **Down Arrow** key to move to the company name or contractor name field.
4. Use the **Alphanumeric** keys to enter a name. Use the **Right Arrow** key to advance from one character to the next.
5. Press **Enter** (↵) to save or **Escape** (⏏) to exit without saving changes.

*Note: The Contractor Name field only applies to the LT 8600.*

## Setting Autotest Preferences

Autotest can be set to automatically stop on the first failed test, and to print, save, and name test results at the completion of each test series.

**Table 3-4: Autotest Preference Options**



Option	Action
Stop on Fail	Autotest aborts at the first failed test. Otherwise, Autotest continues until all tests are completed, regardless of results. <i>Note: If a wire map cannot be reliably completed due to gross miswiring, the Autotest may abort regardless of the setting of this preference.</i>
Auto Increment	Autotest automatically increments the Single and Double Cable ID test counters.
AutoSave	Autotest automatically names and saves any passed Autotest results. Failed tests are <i>not</i> automatically saved.
Graphs	Displaying graphs on the DH requires data to be transferred from the RH to the DH. To save time during testing, do not select this option.

1. From the Preferences screen, select the **Autotest Preferences** option. The Autotest Preference screen displays.

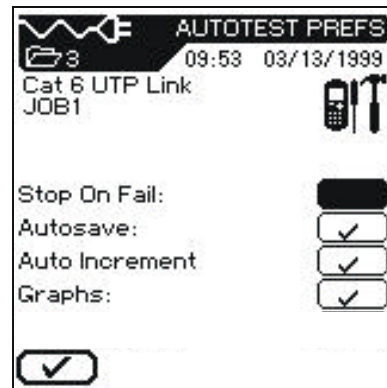
Use the **Arrow** keys to position the cursor next to the desired option.







2. Press  to select or deselect an option.

3. Press **Enter**  to activate the selected Autotest Preferences.
4. Press **Enter**  to save or **Escape**  to exit without saving changes.

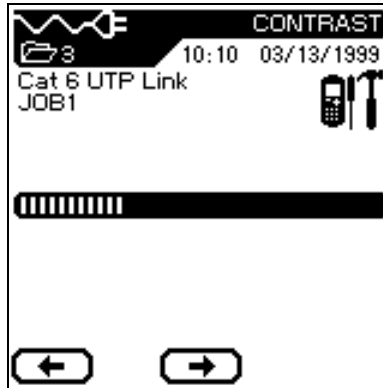
### Adjusting the Display Contrast

1. From the Preferences screen, select the **Display Contrast** option. The Display Contrast screen displays.



2. Press the  or  key to adjust the screen contrast.
3. Press **Enter**  to save or **Escape**  to exit without saving changes.

## Setting Timeout Options

Use this option to set tester time-out options to help conserve battery power when the tester is not in use.





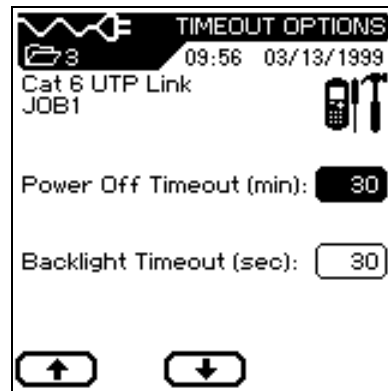

**Table 3-5: Default Timeout Settings**

Backlight	30 seconds
Power	30 minutes

1. From the Preferences screen, select **Timeout Options**. The Timeout Options screen displays with the cursor on the **Backlight Timeout** option.

*Note: The timers begin counting from the last key press.*





2. Press the  or  soft key to adjust the Backlight Timeout setting.
3. Press the **down cursor arrow** to select the Power Off Timeout option.
4. Press the  or  soft key to adjust the Power Off Timeout parameter.
5. Press **Enter**  to save or **Escape**  to exit without saving changes.

## Setting Length Measurement Units

Use this option to set the unit of measurement parameter for length measurements. The unit default setting is “feet.”

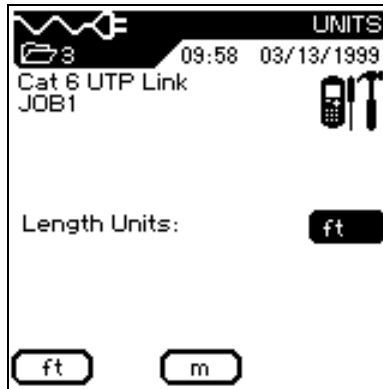
1. From the Preferences screen, select the Measurement Units Option. The Measurement Units screen appears.



2. Select the **left or middle option** key to set the unit of measure parameter to feet or meters.
3. Press **Enter**  to save or **Escape**  to exit without saving changes.





## Configuring the PC or Printer Interface

Use this option to configure the serial port and select the type of printer being used.

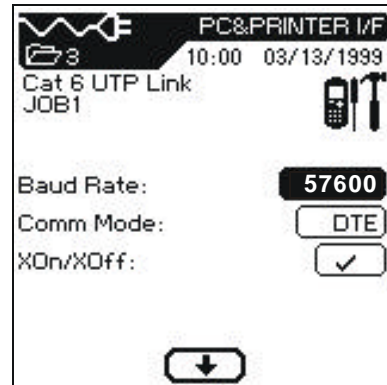
1. From the Preferences screen, select the **PC & Printer I/F** option. The PC & Printer I/F screen appears.

*Note: DTE is selected for uploading to a PC. DCE is selected for direct printing to a printer using the serial port.*



2. Press the **Arrow** keys to position the cursor next to the desired parameter.
3. Press the  or  key to select the desired setting.
4. Press **Enter**  to save or **Escape**  to exit without saving changes.

## Configuring the Talkset



All LT 8000 Series testers are “talkset ready.” Use this option to establish communications between the DH and the RH through an externally attached microphone/headset.

There are two modes of talkset operation: manual and auto.

- In manual mode, the talkset option is activated or deactivated using the soft keys at the bottom of the DH screen.
- Selecting Automatic in the Talkset Preference screen will enable the talksets after each Autotest.

During testing (Autotest or Analyze), the talksets are temporarily disabled until the test has completed. The talkset stays active until the cable under test connection is broken, the talkset cable is unplugged, or the option is deactivated by toggling the “speaker” soft key icon at the bottom of the Ready screen. The state of this selection is indicated by the “speaker” icon at the top of each screen and the “Talkset LED” on the RH.

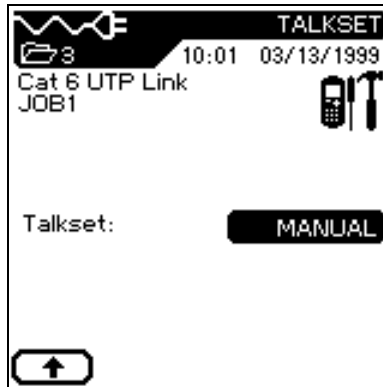

1. From the Preferences screen, select the **Talkset** option. The Talkset screen displays.
2. Press the **Arrow** keys to position the cursor next to the desired parameter

The default setting for Talkset is “Manual”. Press the  or  key to select the desired setting.



## Chapter 3 Self Tests, Calibration, and Configuration

---





3. To talk with someone using the talkset both the Display Handset and the Remote Handset must be connected to a cable with any of the LT 8000 Series adapters.
4. Adjust the audible volume in the earpiece by using the volume control wheel on the talkset's cord.
5. Press **Enter**  to save or **Escape**  to exit without saving changes.

### Setting Date & Time

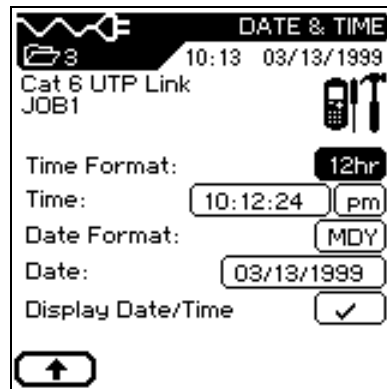
Accurate date and time settings are necessary to create reliable stored record and report information.

1. From the Preferences screen, select the **Date & Time** option. The Date & Time screen displays.



2. Use the **Arrow** keys to position the cursor next to the parameter to be changed.
3. Press the  or  keys, or **Alphanumeric** keys to enter the desired setting.
4. Repeat steps 2 and 3 until the desired parameters have been set.
5. Press **Enter**  to save or **Escape**  to exit without saving changes.





## Selecting a Display Language

You can select one of six languages for the tester display screen:

- English (Default)
- Italian
- French
- Portuguese
- German
- Spanish

1. From the Preferences screen, select the **Language** option. The Language screen displays.



2. Press the  or  key to select the desired language.
3. Press **Enter**  to save or **Escape**  to exit without saving changes.

## Restoring Factory Defaults

Use this option to reset all unit parameters to their factory default settings.

1. From the Preferences screen use the **Arrow** keys to position the cursor on the Restore Defaults option.
2. Press the **Enter**  key to set all unit parameters to their factory default settings.

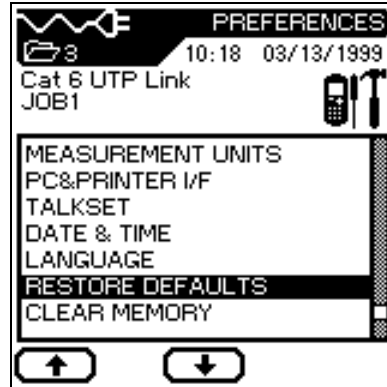

## Clear Memory

Use this option to clear the tester memory.

1. From the Preferences screen use the **Arrow** key to position the cursor on the Clear Memory option.
2. Press the **Enter**  key to clear tester memory.

*Note: There is no undelete option when clear memory is used. All stored tests will be permanently deleted.*

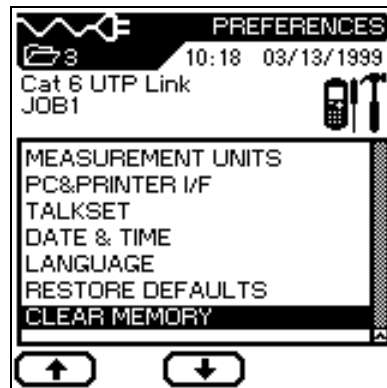

## Tone Generator

The RH can generate a “warble” tone (alternating 900 / 1100 Hz tone at 2 Hz rate) that is detectable by most standard inductive amplifier such as the Wavetek 542SP.

### To activate the Tone Generator:

1. Connect the RH to the cable under test.
2. Press the **Tone** key on the RH.
3. The Tone LED on the RH will illuminate when the Tone Generator is active.

### To turn the Tone Generator off, perform one of the following actions:

1. Press the Tone button.
2. Connect the DH to the other end of the link under test.
3. Allow the tester to remain idle. After five minutes with no test activity the Tone Generator automatically turns off.

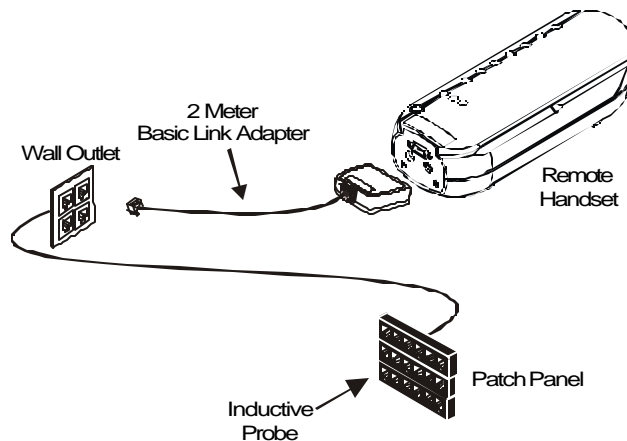

**Figure 3-2: Typical Tone Generator Setup**

## Cable ID/AutoName Option

### Cable IDs and Test Numbering

#### Single and Double Cable IDs

There are two levels of AutoName capability: Single and Double ID. The Double ID feature has many benefits:

- Both ends of the cable under test are clearly identified.
- While reviewing saved test records, potential problems can be identified and quickly located.

If the *Autosave* Autotest preference is selected, names will automatically be assigned to completed tests.

- You can assign a maximum of two unique ten-character cable names for the cable under test (Double ID).
- The tester defaults to a single naming mode (Single ID). The following three screens are examples of unique Single and Double Cable IDs.

1. **Example:**  
**Single ID**

A unique five-character name *PANEL*, followed by a four-character incrementing counter field. The counter is set by default or by the user to start at *0000* and ends at *9999*.

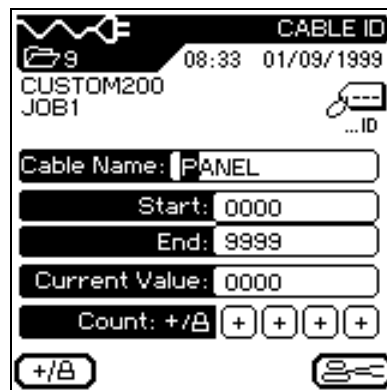

2. **Example:**  
**Double ID “Cable To”**

A unique six character name *OFFICE*, followed by a four character incrementing counter field. This example set by the user to start at *000A* and end at *009D*.

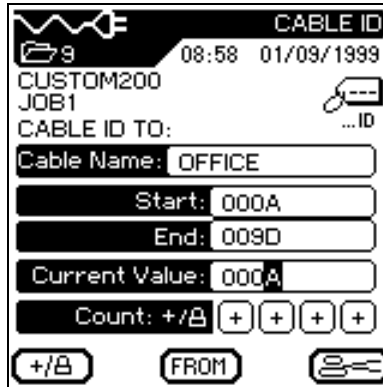

Note: The **FROM** button is used to switch to the Cable From screen.

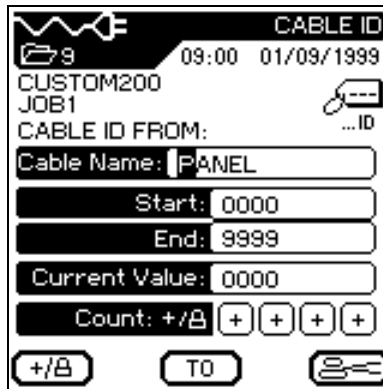

3. **Example:**  
**Double ID “Cable From”**

A unique five character name *PANEL*, followed by a four character incrementing counter field. This example set by the user to start at *0000* and end at *9999*.















Note: The **TO** key is used to switch to the Cable To screen.

**Test Counter**

In addition to the cable name, you can assign up to four incrementing characters to identify individual tests. A  symbol below a counter field signifies a non-incrementing field. A  symbol signifies an auto-incrementing field. Like the decimal numbering system, the counter always begins incrementing from the right most unlocked digit. The default numbering scheme is set to start counting from 0000, and end at 9999. Custom numbering schemes may be used. Refer to Table 5-1 and 5-2 for Single and Double ID counter numbering samples.

**Table 3-6: Single ID Counting Samples**

<b>Default Example</b>	<b>Custom Examples</b>	
Cable Name: TEST	Cable Name: PANEL	Cable Name: PANEL
Start: 0 0 0 0	Start: 0 0 0 0	Start: 0 0 0 A
End: 9 9 9 9	End: 0 0 2 2	End: 0 9 9 D
Locked:    	Locked:    	Locked:    
Current: 0 0 0 0	Current: 0 0 0 0	Current: 0 1 8 A
0 0 0 0	0 0 0 0	0 1 8 A
0 0 0 1	0 0 0 1	0 1 8 B
0 0 0 2	0 0 0 2	0 1 8 C
0 0 0 3	0 0 1 0	0 1 8 D
0 0 0 4	0 0 1 1	0 1 9 A
0 0 0 5	0 0 1 2	0 1 9 B
0 0 0 6	0 0 2 0	0 1 9 C
0 0 0 7	0 0 2 1	0 1 9 D
0 0 0 8	0 0 2 2	0 2 0 A
0 0 0 9	0 0 0 0	0 2 0 B
0 0 1 0	0 0 0 1	0 2 0 C
0 0 1 1	0 0 0 2	0 2 0 D
0 0 1 2	0 0 1 0	0 2 1 A

**Table 3-7: Double ID Counting Sample**

<b>“Cable To”</b>
Cable Name: OFFICE
Cable Counter
Start: 0 0 0 A
End: 0 0 9 D
Locked: ⊕⊕⊕⊕
Current: 0 0 0 A
0 0 0 A
0 0 0 B
0 0 0 C
0 0 0 D
0 0 1 A
0 0 1 B
0 0 1 C
0 0 1 D
0 0 2 A
0 0 2 B
0 0 2 C
0 0 2 D
0 0 3 A

<b>“Cable From”</b>
Cable Name: PANEL
Cable Counter
Start: 0 0 0 0
End: 9 9 9 9
Locked: ⊕⊕⊕⊕
Current: 0 0 0 0
0 0 0 0
0 0 0 1
0 0 0 2
0 0 0 3
0 0 0 4
0 0 0 5
0 0 0 6
0 0 0 7
0 0 0 8
0 0 0 9
0 0 1 0
0 0 1 1
0 0 1 2

### Opening the Single/Double Cable ID Screen:

1. Select the **Cable ID** icon to open the main Cable ID screen.
2. The screen that appears will reflect the *most recently assigned* Cable ID (either single or double). To toggle between Single and Double ID screens, position the cursor over the Select Single or select Double ID option.

Single ID Screen

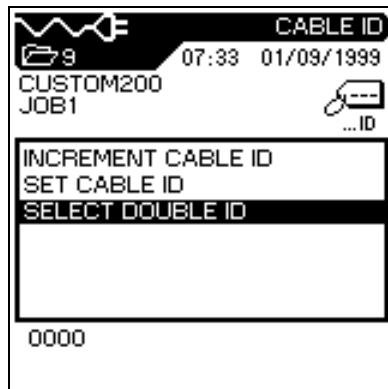

Double ID Screen

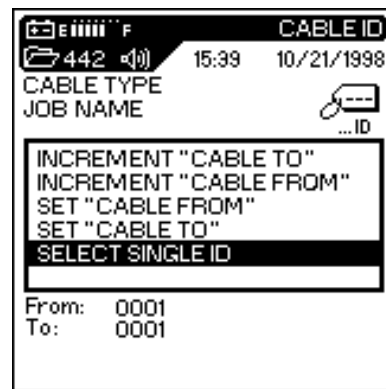

3. The following options may be executed from the main Cable ID screens:
  - Increment Cable ID (*Cable From* and *Cable To* in Double ID mode)
  - Set Cable ID (*Cable From* and *Cable To* in Double ID mode)
  - Select either Single or Double IDs for tests.
4. Press **Enter** (↵) to save changes.
5. Press (⏪) to return to the previous screen after setting the printer communication settings.

**To set a Cable ID:**



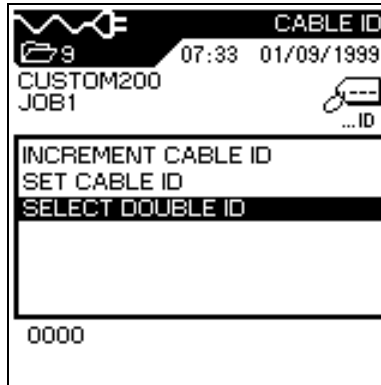

1. In the Cable ID screen, position the cursor over the **Set Cable ID** option.
2. Press **Enter**  to open the Double ID screen.

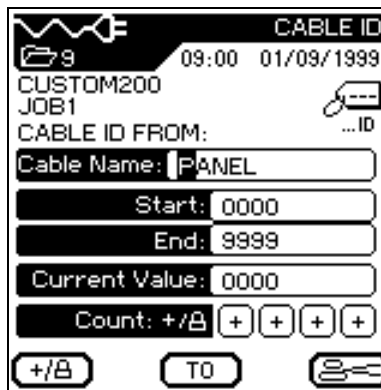

*Note: The screen that appears will reflect the most recently assigned Cable ID (either Single or Double). Double ID is used in this example.*

3. Enter the following parameters as required:



- a. *Cable From* name, ten characters maximum.
  - b. Counter Start and End points, four characters each. Counter will reset at the end point.
  - c. Select the  symbol to lock a character, or  to allow a character to auto-increment.
  - d. Use the  key to go to the *Cable To* screen. Repeat steps a through c.
4. After entering the desired *Cable From* and *Cable To* names and parameters, press **Enter**  to save and return to the Main Cable ID screen.

## Selecting a Cable Type



The tester comes with several cable types stored in non-volatile memory. When a cable type is selected, the recommended limits for that cable are automatically programmed into the tester.

Cable choices are made by topology:

- Twisted Pair Basic Link
- Twisted Pair Channel Link
- Miscellaneous Types
- Ethernet
- Token Ring
- Custom Cable
- Fiber

*Note: All LT 8000 Series testers also support custom cable types.*

### To select a cable type:

1. Press the **Cable Selection**  hard key. The Cable Types screen appears.
2. Press **Enter**  to select a cable type and its associated default NVP for testing.

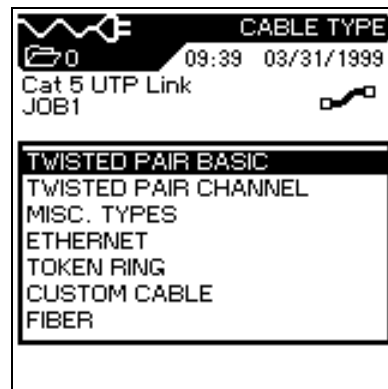

3. Position the cursor and press **Enter** (↵) to change to a new cable type and its associated default NVP for testing.

The Information screen appears briefly to confirm your cable selection.

*Note: A number of unique cable manufacturer NVP values are stored in the tester memory. To access the list of manufacturer cables for the currently highlighted test standard, press the  soft key.*

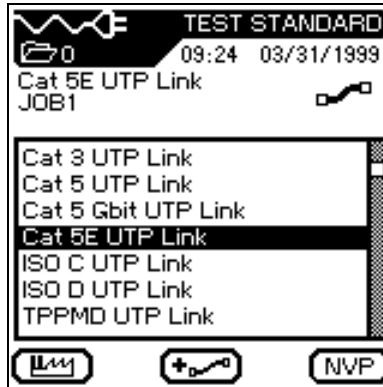

4. Press the  soft key if you want to use the selected cable as the basis for a Custom Cable.

The tester will display the Custom Cable screen.

You can then change default cable features and save the cable as a Custom Cable.

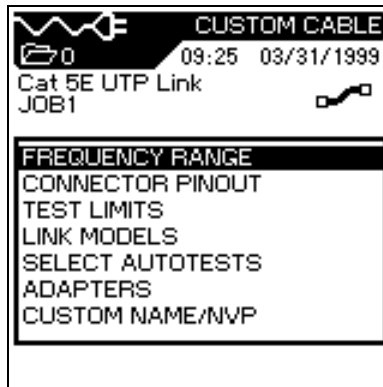

**To change the default NVP value:**

1. From the Test Standard screen, press the **NVP** key to select the Change NVP option. The NVP screen will display.

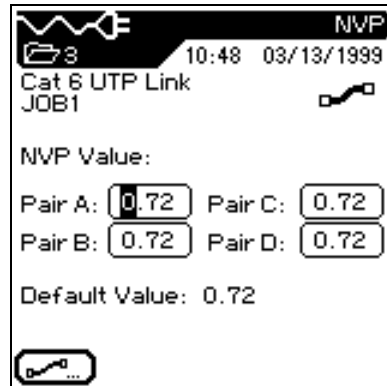

2. To manually enter a new NVP value, use the **Arrow** keys to position the highlighted cursor and enter new NVP values.
3. To automatically calculate a new NVP value, press **Measure** to select the Measure NVP option. The Measure NVP screen appears.
4. Connect a test cable of known length.
5. Using the **Arrow** and **Number** keys, enter the known cable length.
6. Press the **Play** key to calculate a new NVP value. The display returns to the main NVP screen after the new NVP value has been calculated.

*Note: For ISO Standards enter the known cable length plus 4 meters.*



## Custom Cable Settings

All of the cable types pre-programmed into the LT 8000 Series testers are associated with a predefined test standard. You cannot change these pre-programmed parameters. If you want to run a different set of tests for a given cable you must create a Custom Cable.

For example, if you would like to run Return Loss in addition to the TIA 568A TSB-67 Category 5 tests (Return Loss is not a required TIA or TSB-67 test), you must create a Custom Cable and select the tests you want to include in the test suite for this cable.

A maximum of ten custom cable settings can be created, stored, removed and retrieved when needed.

### To create a new custom cable type:

1. Press the **Cable Selection**  hard key. The Cable Types screen displays.
2. Use the arrow keys to position the cursor over the desired cable topology cursor and press **Enter** . The Test Standard screen displays.

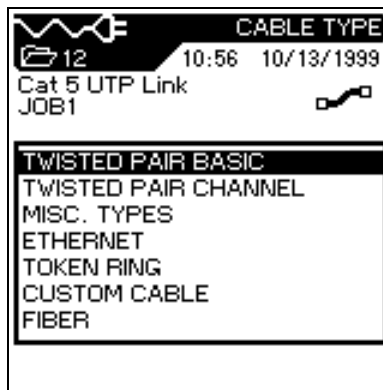

### Chapter 3 Self Tests, Calibration, and Configuration

---

3. Position the cursor over the desired cable type and press the  key. The Custom Cable parameters screen displays.

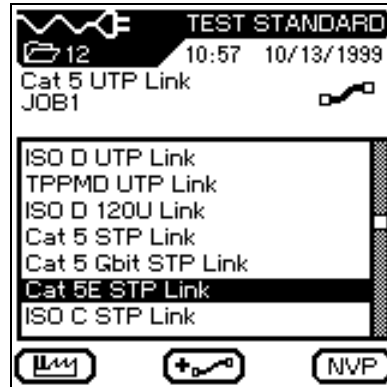

4. Change the desired cable parameters, then proceed to the next step to name the cable.
5. Position the cursor over Custom Name/NVP and press **Enter** . The NVP Screen appears.

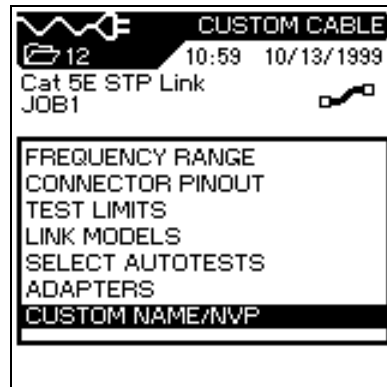

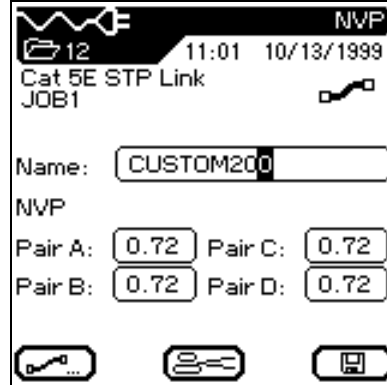

6. Change NVP parameters as required and then name your new custom cable.
7. Press the **Save** function key.
8. Press **Enter**  to return to the Custom Cable screen. The new custom cable is now selected as the cable under test.



**To select or delete a custom cable type:**

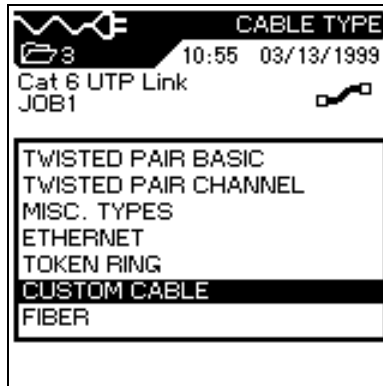

1. Press the **Cable Selection**  hard key. The Cable Types screen appears.



2. Press the arrow keys to select **Custom Cable**.
3. Press **Enter**  to open the Custom Cable screen.

4. The tester displays any stored custom cable types.

5. Position the cursor over the desired custom cable type.

6. Press **Enter**  to make the custom cable you highlighted the new cable type, or press the  key to delete the selected custom cable type.

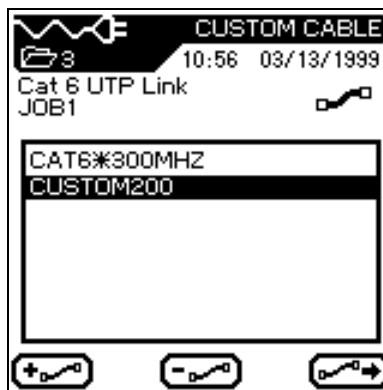



*Note: Custom cables can not be deleted if there are stored tests associated with the cable.*

**To edit an existing custom cable type :**

1. Press the **Cable Selection**  hard key. The Cable Types screen appears.

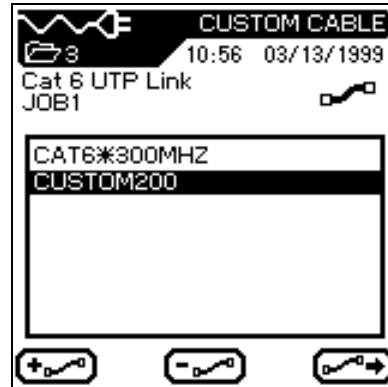
2. Open the Custom Cable screen and select the cable type to be customized.



3. Press the  soft key.  
The Custom Cable parameter screen displays.

*Note: Custom cables can not be deleted if there are stored tests associated with the cable.*

4. Position the cursor on the desired custom cable parameter and press the **Enter**  key to edit the settings.

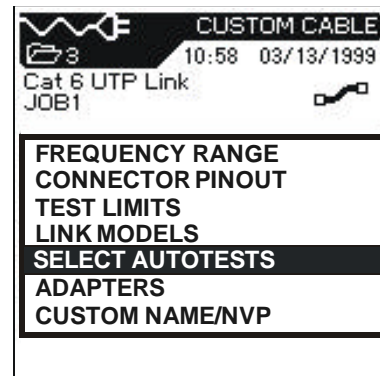

5. After making the desired changes, select the Custom Name/NVP option.  
The NVP screen displays.

6. Save the cable under its current name or under a new name

*Note: Refer to the next page for a description of custom cable parameter options.*

## Custom Cable Parameters

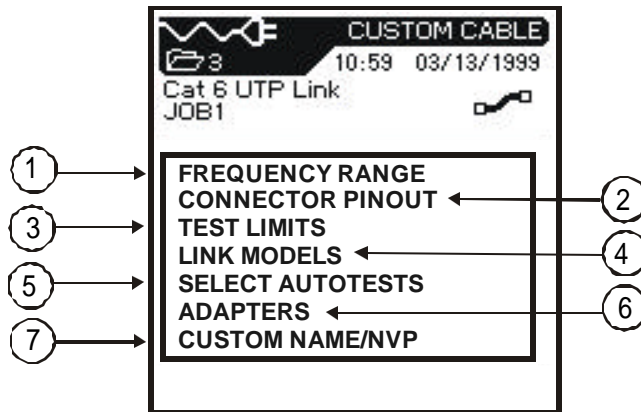

**Figure 3-3: Custom Cable Parameter Screen**

**Table 3-8: Custom Cable Parameter Options**

	<b>Parameter Option</b>	<b>Description</b>
1.	Frequency Range	Use this menu to set minimum and maximum certification and cable grade frequencies.
2.	Connector Pinout	This screen is used to define connector pinouts. <i>Note: If one wire pair is not selected, tests for NEXT, attenuation, capacitance, DC resistance, and impedance will not be performed on that pair.</i>
3.	Test Limits	This screen is used to customize Autotest pass/fail limits.

*(Table Continues)*

**Table 3-8: Custom Cable Parameter Options (Continued)**

	<b>Parameter Option</b>	<b>Description</b>
4.	Link Models	Custom NEXT and Attenuation limits are set by using a flat line limit or one of several different models. Frequency limits will vary from less than 1 MHz to 100 MHz based on the link type. For a detailed description of the methods and limits for calculating NEXT and Attenuation values, refer to <i>Appendix C, Measurement Methods and Limits</i> .
5.	Select Autotests	Not all cables will require the full suite of Autotests. Use this menu to select the Autotests to be run.
6.	Adapters	Use this menu to inform the tester which near-end and far-end cable adapter are currently being used.
7.	Custom Name/NVP	Use the alphanumeric keys to enter a custom name or change the NVP parameters. The LT 8000 Series can store up to 10 custom cables.

# Chapter 4

## LT 8000 Series Cable Testing Fundamentals

---

### Contents

- Physical and electrical characteristics of cables
- Cable test descriptions
- How to set up different cabling tests
- What to do when tests fail

### Invasive LAN Cable Testing

Whenever an electronic test instrument is connected to a circuit to obtain a reading, that unit and its connecting cables become part of the “circuit-under-test.” To some extent, the reading will always reflect the instrument’s participation in the measurement. WWG’s goal has always been to reduce to an absolute minimum the effects the instrument has on the circuit

An LT 8000 Series tester uses special instrument connectors instead of RJ-45 (Modular 8) style jacks for the following reasons:

- RJ-45 connectors add significant crosstalk to higher frequency measurements.
- TIA/EIA’s proposed standards exclude the RJ-45 connection from the end of the model links used to define current LAN cable testing limits.
- RJ-45 connecting hardware is limited to 500-1000 mating cycles before requiring replacement.

## Testing Twisted Pair Cables

Twisted pair wiring systems (Refer to Figure 4-1) typically employ four pairs of insulated conductors and connectors that allow you to operate different network types on the same cable (Refer to Table 4-1). Both unshielded (UTP) and foil shielded (STP, FTP) cables are available.

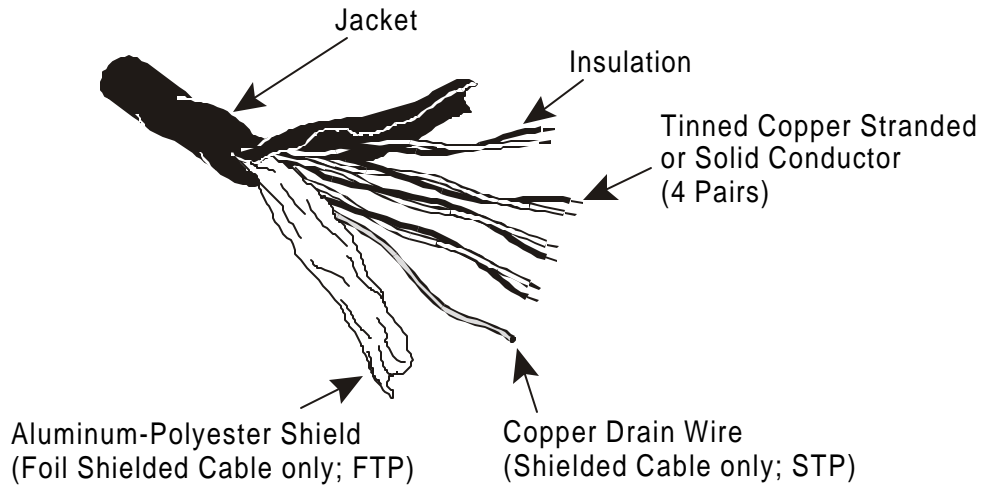

The following diagrams contain modular jack pin numbering and wiring patterns for T568A, T568B, 10 Base-T, TP-PMD, Token Ring and USOC cabling types.

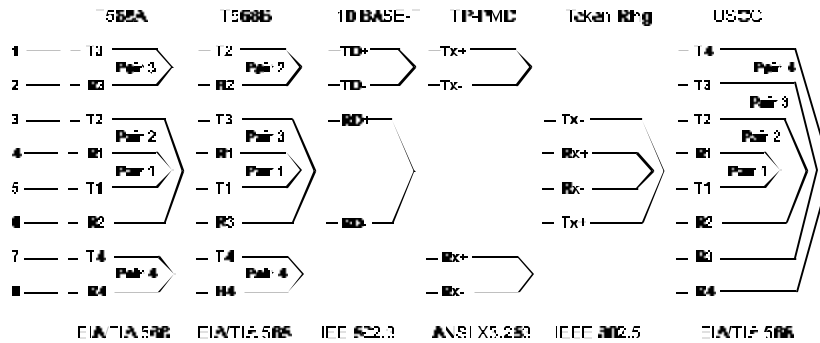

Figure 4-1: Twisted Pair Cables

**Table 4-1: Twisted Pair Cable Types, Associated Networks, and Required WWG Adapters:**

Cable Type	Network Examples	Required Adapters
TIA Cat 3, 4, 5, 5 Gbit, 5E, and 6 UTP or STP	Ethernet, Fast Ethernet, ATM, and Gigabit Ethernet	Basic Link or Channel Link
ISO Class C, D, and E UTP or STP	Ethernet, Fast Ethernet, ATM	
TP-PMD / TP-DDI	FDDI or ATM on Copper	
10Base-T	Ethernet	
Single Pair	Telephone, Apple Local Talk, ISDN	
Shielded Two-Pair (1,2,7,8)	ATM, Fiber Channel on Copper	

### Shielded Twisted Pair (STP)

Testing the continuity of the shield is important and requires shielded test leads at both the Display Handset and Remote Handset. When testing STP, be sure to select Shielded Cable Type (STP) in the Cable Type menu.

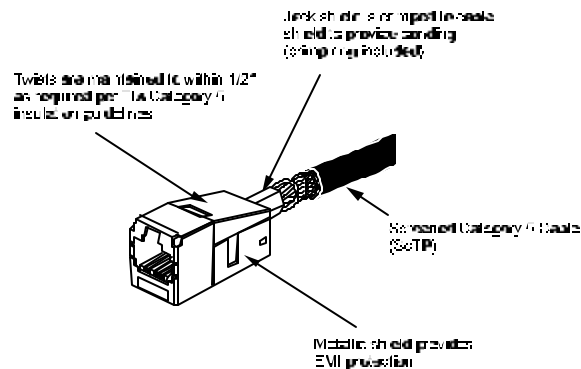

**Figure 4-2: Shield Continuity Test Connections Twisted Pair**

## **USOC Wiring**

If a USOC (Universal Service Ordering Code) or other wiring scheme is used, a special adapter may be required for connection. Refer to *Appendix D, Model Accessories* for a full list of available cable adapters.

*Note: If your testing requirements include connection to something other than an RJ-45 style jack, refer to Testing with Special Adapters later in this chapter.*

## Basic Link Test Setup

ANSI, EIA, TIA, and ISO all provide two network communication circuit specifications: basic link and channel link. A basic link consists of up to 90 meters of horizontal network cabling with basic link test adapters at each end. The basic link (shown below) is used to certify the horizontal network cable installation *before* network connection and user hookup. It excludes user patch cords and jumpers.

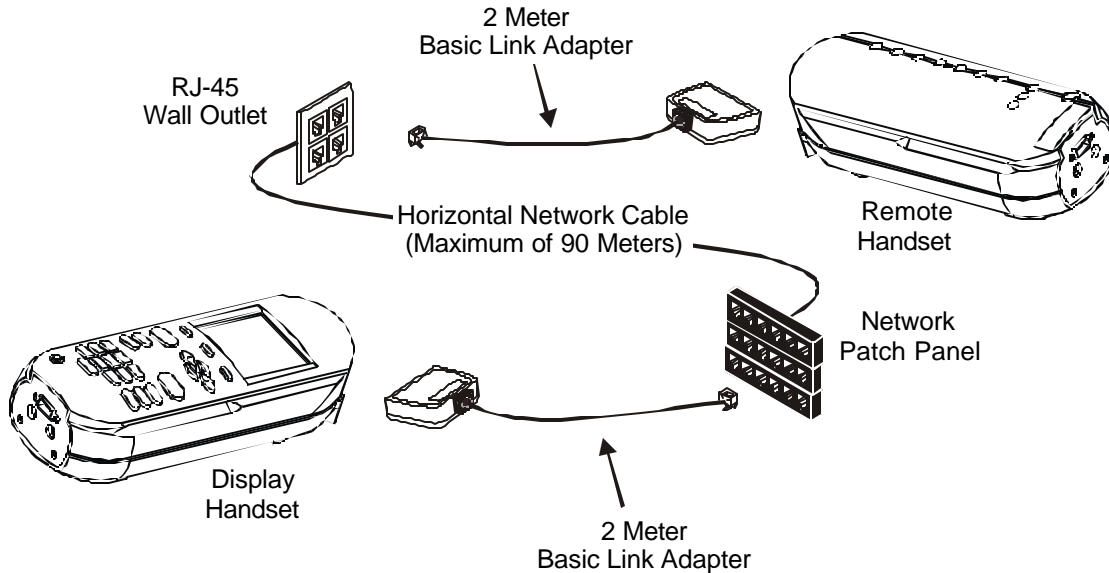

**Figure 4-3: Basic Link Test Connections**

Connection	Cable Length Limits
Horizontal Network Cable	Maximum of 90 meters
Basic Link Channel Adapters	Combined Maximum length of 4 meters

*Note: Don't forget to change the Cable Type to Twisted Pair Basic Link when working with basic link adapters.*

*If you exceed the tester length test limits, the tester is required to fail the link.*

## Channel Link Test Setup

A channel link includes all aspects of the cabling system. It consists of up to 90 meters of horizontal network cabling, user patch cords, and channel adapters at each end. The channel link (shown below) is used to certify the network installation *after* network connection and user hookup.

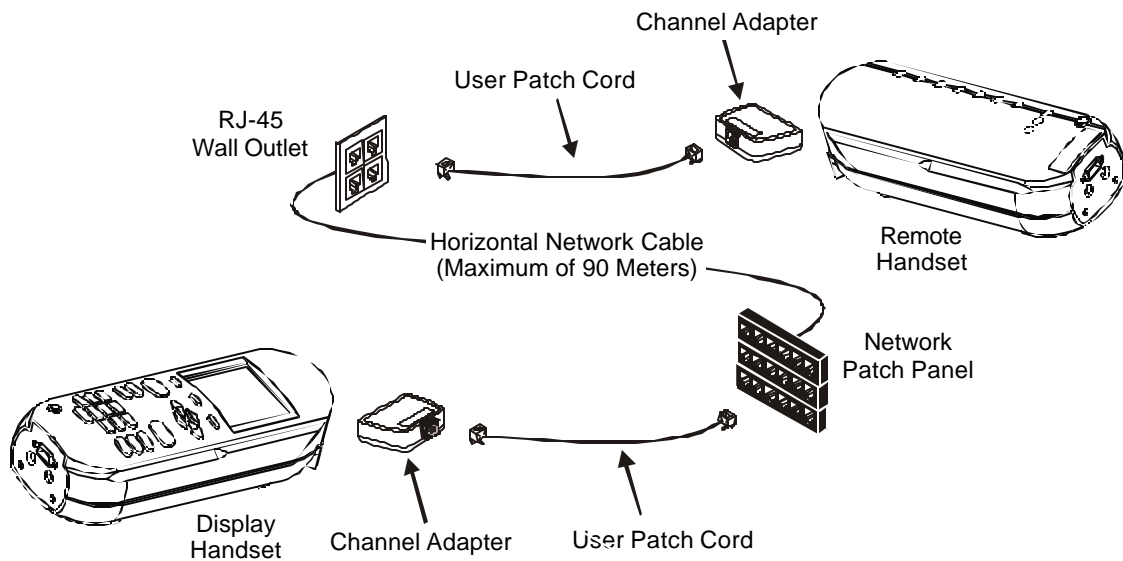

**Figure 4-4: Channel Link Test Connections**

Connection	Cable Length Limits
Horizontal Network Cable	Maximum of 90 meters
User Patch Cords	Combined Maximum length of 10 meters

*Note: Don't forget to change the Cable Type to Twisted Pair Channel Link when working with channel adapters.*

*If you exceed the tester length test limits, the tester is required to fail the link.*

## Wire Map Test

Wire Map testing is used to locate shorts, opens and miswires. Test results are displayed graphically for easy visual indication of any problems.

*Note: The RH is required to perform this test.*

### Wire Map Errors

A failure in a Wire Map should always be the first problem corrected, since it causes faults in other tests. One open pin can cause DC loop resistance and attenuation tests to fail. An open may also cause a zero capacitance reading, and will cause false readings in NEXT tests.

A wire map test will always look for and map all nine possible wires (four pairs + shield) but will only consider wires defined as present in the selected cable type (refer to *Chapter 3, Selecting a Cable Type, Page 3-22*) for pass/fail criteria. For example, a wire that is not specified in the cable type will show on the map but will not cause a test failure.

The Wire Map test guarantees the following minimum level of error detection (based upon four pairs of conductors, shield optional):

- Any wiring error or combination of wiring errors will indicate a wire map failure.
- Any combination of up to three opens, shorts or cross-connections will be correctly identified.
- Opens and shorts will provide an indication of the cable end that the error occurred on (provided by Length screen results in Autotest.).
- Split pairs will be identified based on specific patterns of inconsistent NEXT (Near-End Crosstalk).

## Distance to Fault

The failed wire pair(s) and the calculated distance-to-fault data is displayed at the bottom of the wire map test result screen (refer to the example below). The distance to the fault is always calculated beginning from the DH unit.

*Note: The LCD display is not scaled to represent the calculated distance.*

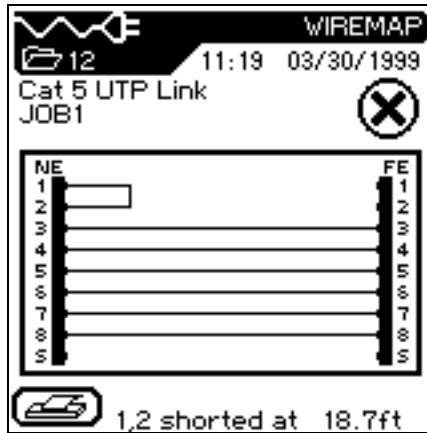

## Troubleshooting Wiremap Problems

### Problem: One or more open pins

Probable Causes	Connector-to-wire punch down not mated Defective jack or plug. Broken wire(s).	
Other Tests Affected	<u>Test</u> DC Resistance: Attenuation: NEXT: Mutual Capacitance: Length:	<u>Possible Result</u> Fail. Fail. Some false measurements. 0 reading possible. May be low if the open is near the Display Handset.

### Problem: Shorted pins

Probable Causes	Conductors making contact at a connector. Jack or plug has pin or circuit defect. Cable damaged.	
Other Tests Affected	<u>Test</u> DC Resistance: Attenuation: NEXT: Capacitance: Length:	<u>Possible Result</u> Low or zero. Fail. Some false measurements. Over limit. Reduced or shorted pairs.

### Problem: Miswired pins

Probable Causes	Conductors reversed at a connector.	
Other Tests Affected	<u>Test</u> Usually none	<u>Possible Result</u> Infrequently, one or more tests may fail.

## Wire Length Test

This test measures the length of each wire pair to make sure that the recommended limits for the particular cable type are not exceeded. Depending on the units selected in the Setup menu, length is reported in either feet or meters. See *Chapter 3, Setup information*.

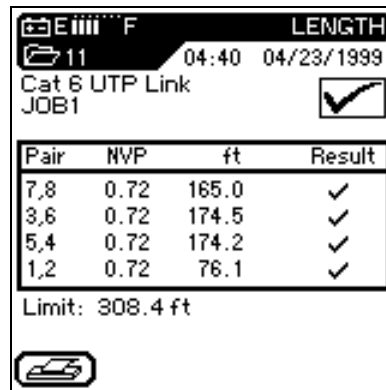

Pair	NVP	ft	Result
7,8	0.72	165.0	✓
3,6	0.72	174.5	✓
5,4	0.72	174.2	✓
1,2	0.72	76.1	✓

Limit: 308.4 ft

*Note: The RH is not required to perform this test.*

### Length and NVP

Measuring the length of the cable requires that you know the Nominal Velocity of Propagation (NVP) of the cable. Refer to the specification or the manufacturer of the cable you are testing for the cable NVP. If the wire specification is not available, use a known length of good cable (50 to 100 feet) and adjust the NVP until the tester displays the known cable length.

### Wire Length Errors

Lengths may differ slightly between pairs in the same cable, due to minor NVP differences between the pairs and physical length differences due to twisting patterns. When electrically measured cable length varies too much from actual length, a problem exists.

## Troubleshooting Wire Length Problems

**Problem: Length between a pair of the same cables varies by more than 10%.**

Probable Causes	Incorrect NVP. Excessive cable length Installed matched terminator not functioning correctly. Cable insulation damage to longer pairs. Break or short in a pair. Elevated capacitance on a pair.						
Other Tests Affected	<table style="width: 100%; border-collapse: collapse;"> <thead> <tr> <th style="text-align: left; border-bottom: 1px solid black;"><u>Test</u></th> <th style="text-align: left; border-bottom: 1px solid black;"><u>Possible Result</u></th> </tr> </thead> <tbody> <tr> <td>DC Loop Resistance:</td> <td>May be slightly high or fail.</td> </tr> <tr> <td>Attenuation:</td> <td>May be slightly high or fail.</td> </tr> </tbody> </table>	<u>Test</u>	<u>Possible Result</u>	DC Loop Resistance:	May be slightly high or fail.	Attenuation:	May be slightly high or fail.
<u>Test</u>	<u>Possible Result</u>						
DC Loop Resistance:	May be slightly high or fail.						
Attenuation:	May be slightly high or fail.						

## DC Resistance Test

This test measures the loop resistance of each pair of wires. The instrument tests to make sure total loop resistance does not exceed recommended limits. Results are displayed with resistance in ohms for each pair, and comparison limit for the cable type.

*Note: The RH is required to perform this test.*

## DC Resistance Errors

All four pairs of a network link should have about the same resistance. Pair resistance that exceeds the limit is indicated as a failure. The maximum limits in the default tables are based on the maximum length limit of the link or cable segment.

## Troubleshooting DC Resistance Problems

### Problem: Excessive Resistance

Probable Causes	Mismatched cable types. Poor punch block connection. Poor RJ-45 termination connections. Wire pair has a tap (never done). Cable damage. Shorted cable.	
Other Tests Affected	<u>Test</u> Wire Map: Attenuation: NEXT: Capacitance:	<u>Possible Result</u> May fail. May fail. May have false readings. May fail.

### Problem: One wire pair has a very high DC loop resistance, others are normal.

Probable Causes	Poor connection points. Cable damage. Connector blades not fully piercing wire insulation. Worn Connector	
Other Tests Affected	<u>Test</u> Wire Map: Attenuation: NEXT: Capacitance:	<u>Possible Result</u> May fail. May fail. May have false readings. May fail.

## NEXT, ELFEXT, and Power Sum Tests

The NEXT (Near End Crosstalk) and ELFEXT (Equal Level Far-End Crosstalk) tests measure crosstalk at the near and far ends of the cable in one Autotest. High levels of crosstalk can cause excessive retransmissions, data corruption, and other problems that slow the network system.

*Note: The RH is required to perform these tests.*

### NEXT and ELFEXT

The NEXT test measures cross-talk from a transmitting pair to an adjacent pair in the same cable sheath. NEXT is measured at the both the DH and the RH.

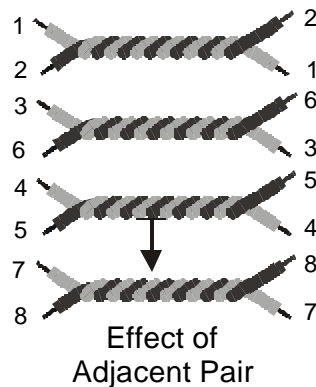

The ELFEXT test is similar to the NEXT test except that the traffic is generated at the RH and crosstalk is measured at the DH.

- NEXT measurements are made at *each end* of the cable for all pair combinations (pair 1-2 vs. 3-6, etc.), yielding a total of twelve measurements.
- ELFEXT measurements are made at the DH for all possible pair combinations (1-2 vs. 3-6, 3-6 vs. 1-2, 1-2 etc.) yielding a total of twelve measurements.

### **Power Sum NEXT and Power Sum ELFEXT**

Power Sum tests measure the crosstalk effects of three transmitting pairs on the fourth pair in the same cable sheath.

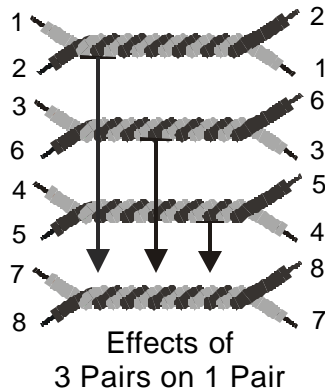

- During the Power Sum NEXT test, six measurements are made at *each end* of the cable and combined (pairs 1-2 / 3-6 / and 4-5 vs. Pair 7-8, etc.) for a total of eight measurements.
- During the Power Sum ELFEXT test, twelve measurements are made at the DH side of the cable and combined (pairs 1-2 / 3-6 / 4-5 vs. Pair 7-8, etc.) for a total of four measurements.

*Note: Power Sum NEXT measurements will generally read 2 - 3 dB lower in value (higher crosstalk) than conventional NEXT.*

### **NEXT and ELFEXT Errors**

Crosstalk is usually caused by poor connector termination on the ends of the cable. The smaller the number, the greater the crosstalk.

## Troubleshooting NEXT and ELFEXT Problems

### Problem: Low dB test readings

Probable Causes	Installed cable or patch cable not correctly rated. Defective, poor quality cable or too many connectors. Poor quality installation at the connection points. Too much insulation has been stripped from the wires at termination. A pair of wires has been untwisted too much at termination. Split-pairs. Poor quality connectors or connectors not rated to desired category. Delay skew (ELFEXT).						
Other Tests Affected	<table border="0"><thead><tr><th data-bbox="613 772 893 804"><u>Test</u></th><th data-bbox="893 772 1325 804"><u>Possible Result</u></th></tr></thead><tbody><tr><td data-bbox="613 804 893 840">Return Loss:</td><td data-bbox="893 804 1325 840">May be over limit.</td></tr><tr><td data-bbox="613 840 893 896">NEXT:</td><td data-bbox="893 840 1325 896">May show same symptoms.</td></tr></tbody></table>	<u>Test</u>	<u>Possible Result</u>	Return Loss:	May be over limit.	NEXT:	May show same symptoms.
<u>Test</u>	<u>Possible Result</u>						
Return Loss:	May be over limit.						
NEXT:	May show same symptoms.						

## Attenuation Test

This test measures the overall signal strength loss in the cable and verifies that it is within acceptable limits. Low attenuation is essential for error-free transmission. Attenuation is measured by injecting a signal of known amplitude at the Remote Handset and reading the amplitude at the Display Handset.

*Note: The RH is required to perform this test.*

## Attenuation Errors

Attenuation causes a loss of signal strength over a cable. The loss increases with cable length, signal frequency, and temperature. Attenuation testing can be used to find problems in the cable, connectors or connecting hardware. The larger the number, the greater the attenuation.

## Troubleshooting Attenuation Problems

### Problem: High Attenuation Reading

Probable Causes	Poor connector termination points. Excessive cable length. Incorrect or poor quality adapter cable. Incorrect cable.														
Other Tests Affected	<table border="0"> <thead> <tr> <th data-bbox="708 1182 992 1209"><u>Test</u></th> <th data-bbox="992 1182 1427 1209"><u>Possible Result</u></th> </tr> </thead> <tbody> <tr> <td data-bbox="708 1209 992 1241">DC Loop Resistance:</td> <td data-bbox="992 1209 1427 1241">May be high.</td> </tr> <tr> <td data-bbox="708 1241 992 1272">Capacitance:</td> <td data-bbox="992 1241 1427 1272">May be high.</td> </tr> <tr> <td data-bbox="708 1272 992 1304">Length:</td> <td data-bbox="992 1272 1427 1304">May be over limit.</td> </tr> <tr> <td data-bbox="708 1304 992 1335">NEXT:</td> <td data-bbox="992 1304 1427 1335">May be low on pair combinations.</td> </tr> <tr> <td data-bbox="708 1335 992 1367">Average Impedance:</td> <td data-bbox="992 1335 1427 1367">May be low.</td> </tr> <tr> <td data-bbox="708 1367 992 1398">Return Loss:</td> <td data-bbox="992 1367 1427 1398">May be over limit.</td> </tr> </tbody> </table>	<u>Test</u>	<u>Possible Result</u>	DC Loop Resistance:	May be high.	Capacitance:	May be high.	Length:	May be over limit.	NEXT:	May be low on pair combinations.	Average Impedance:	May be low.	Return Loss:	May be over limit.
<u>Test</u>	<u>Possible Result</u>														
DC Loop Resistance:	May be high.														
Capacitance:	May be high.														
Length:	May be over limit.														
NEXT:	May be low on pair combinations.														
Average Impedance:	May be low.														
Return Loss:	May be over limit.														

## Return Loss Test

This test measures the ratio of reflected to transmitted signal strength. Good quality cable runs will have little reflected signal, indicating good impedance matches in the run's various components.

*Note: The RH is required to perform this test.*

## Return Loss Errors

Like attenuation, excessive return loss reduces signal strength at the receive end. It also indicates a mismatched impedance at some point along the cable run.

A value of 20 dB or greater indicates a good twisted pair cable. A value of 10 dB or less is very bad, and causes a large reflection of signal back to the source.

## Troubleshooting Return Loss Problems

### Problem: Excessive Return Loss (Value of 10 dB or less)

Probable Causes	<p>Open, shorted, or damaged cable.</p> <p>Installed cable, cable segments, or patch cord have improper characteristics.</p> <p>Damaged or worn cable or connectors.</p> <p>Poor punch-down.</p> <p>Factory splice in cable.</p>								
Other Tests Affected	<table style="width: 100%; border-collapse: collapse;"> <thead> <tr> <th style="text-align: left; border-bottom: 1px solid black;"><u>Test</u></th> <th style="text-align: left; border-bottom: 1px solid black;"><u>Possible Result</u></th> </tr> </thead> <tbody> <tr> <td>Attenuation:</td> <td>May be high.</td> </tr> <tr> <td>Capacitance and Average Impedance:</td> <td>Could be affected if the impedance mismatch is caused by cable damage.</td> </tr> <tr> <td>DC Loop Resistance:</td> <td>May be high if due to a poor punch-down.</td> </tr> </tbody> </table>	<u>Test</u>	<u>Possible Result</u>	Attenuation:	May be high.	Capacitance and Average Impedance:	Could be affected if the impedance mismatch is caused by cable damage.	DC Loop Resistance:	May be high if due to a poor punch-down.
<u>Test</u>	<u>Possible Result</u>								
Attenuation:	May be high.								
Capacitance and Average Impedance:	Could be affected if the impedance mismatch is caused by cable damage.								
DC Loop Resistance:	May be high if due to a poor punch-down.								

## **Average Impedance Test**

Average impedance is derived from electrical delay and capacitance measurements. The results of this test are expressed in ohms. Average impedance testing can help identify physical damage to the cable, connector defects, or cable segments with incorrect characteristic impedance.

This test uses capacitive measurements; therefore, it is necessary to specify the correct cable type in order to accurately perform the test.

*Note: If a CAT 3 cable is selected (specified as the cable type where PVC is used in the cable insulation) but a CAT 5 cable (where Teflon is used as the cable insulation) is actually used, the average impedance will be calculated incorrectly. To avoid this problem, be sure to specify the correct cable type.*

*Note: The RH is not required to perform this test.*

## **Impedance Errors**

Impedance errors cause signal reflection and strength reduction. Average impedance of each pair should be equal to the LAN system impedance of 100, 120, or 150  $\Omega$ , plus or minus 15  $\Omega$ .

## Troubleshooting Impedance Problems

### Problem: High Impedance Readings

Probable Causes	Compression, stretching, or excessive bending damage to the cable. Defective connectors. Insulation damage at a connector. Ground loops created between cable shielding (if used) and equipment grounding (via RS-232 cable to computer, or auxiliary power). Improperly chosen cables or patch cords. Moisture in the cable.						
Other Tests Affected	<table border="1"><thead><tr><th data-bbox="613 737 889 768"><u>Test</u></th><th data-bbox="889 737 1320 768"><u>Possible Result</u></th></tr></thead><tbody><tr><td data-bbox="613 768 889 804">Length:</td><td data-bbox="889 768 1320 804">Affected pairs will appear longer.</td></tr><tr><td data-bbox="613 804 889 942">Average Impedance:</td><td data-bbox="889 804 1320 942">Change in average impedance is inversely proportional to change in capacitance.</td></tr></tbody></table>	<u>Test</u>	<u>Possible Result</u>	Length:	Affected pairs will appear longer.	Average Impedance:	Change in average impedance is inversely proportional to change in capacitance.
<u>Test</u>	<u>Possible Result</u>						
Length:	Affected pairs will appear longer.						
Average Impedance:	Change in average impedance is inversely proportional to change in capacitance.						

## **Delay and Skew Test**

This test measures the period of time for a test signal applied to one end of a cable run to reach the other end. Skew indicates the difference between the measured time delay for that pair and the pair with the lowest value (displayed as 0.0 ns). Delay and Skew limits are set according to the currently selected cable type.

*Note: The RH is not required to perform this test.*

## **Delay and Skew Errors**

Delay and skew measurements will usually differ slightly between pairs in the same cable. A substantial difference indicates a cable installation problem or a pair defect.

## **Troubleshooting Delay and Skew Problems**

### **Problem: Excessive Differences Between Measurements**

Probable Causes	Cables which use different materials for insulating the four pairs of wires. A break or short in the pair. Excessive cable length. Cable installation problems.
-----------------	--

## Capacitance Test

This test measures the mutual capacitance between the two conductors of each wire pair to verify that installation has not affected the capacitance for the particular cable type. Bulk capacitance measurements are displayed in nanofarads (nF) in the Analyze Capacitance test. Autotest measures the bulk capacitance in picofarads (pF) per foot or meter.

*Note: The RH is not required to perform this test.*

## Capacitance Errors

The larger the capacitance, the higher the error rate. Small changes in the capacitance measurements are normal due to the handling of the cable during shipping and installation. The addition of connectors and patch cables will also affect capacitance values.

## Troubleshooting Capacitance Problems

### Problem: Capacitance Exceeds the Maximum Limit

Probable Causes	Compression, stretching, or excessive bending damage to the cable. Defective connectors. Insulation damage at a connector. Ground loops created between cable shielding (if used) and equipment grounding (via RS-232 cable to computer, or auxiliary power). Improperly chosen cables or patch cords. Moisture in the cable. Poor connections at punch downs and wall plates
-----------------	---

**Chapter 4**  
**LT 8000 Series Cable Testing Fundamentals**

---

<u>Other Tests Affected</u>	<u>Test</u>	<u>Possible Result</u>
	Length: Average Impedance:	Affected pairs will appear longer. Change in average impedance is inversely proportional to change in capacitance.

## **ACR Test**

The ACR (Attenuation-to-Crosstalk Ratio) test performs a mathematical comparison (difference calculation) between the results of the Attenuation and NEXT tests. The difference reading between each pair gives an indication of how problem-free the cable pair will be for transmissions.

The ACR measurements are calculated pair-to-pair. The Power Sum ACR measurements are calculated by summing the NEXT between a selected pair and the other three pairs in the same cable sheath.

*Note: The RH is required to perform these tests.*

### **ACR and Power Sum ACR Errors**

A large difference reading is desirable, since it indicates a strong signal and little noise interference.

### **Troubleshooting ACR and Power Sum ACR Problems**

Refer to the NEXT (page 4-15) and Attenuation (4-16) troubleshooting suggestions in this chapter.

## **Headroom Test**

The Headroom measurement is a mathematical analysis of the data already existing from previous tests. The calculated value is the sum of the Power Sum ACR test (Power Sum ACR of the worst pair after the attenuation for that pair has been normalized to 100 meters or 328 feet) and the additional margin between the worst case PS NEXT and the limit for PS NEXT.

Headroom provides a simplified means of reporting the margin available in a single cable run which will support an application with error-free performance. It also gives an indication of additional margin, which may be achieved through the utilization of “enhanced” cable and connectors and careful installation practices.

*Note: The RH is required to perform this test.*

## **Headroom Errors**

The Headroom number, reported in dB, characterizes the worst-case margin found in a single cable run. A large number is desirable, since it indicates a strong signal and little noise interference. The pass/fail limit for Headroom is the same as Power Sum ACR.

## Testing and Troubleshooting 10BASE-T Cabling

10BASE-T Ethernet systems use twisted pair cabling for transmission of network data frames. Both the cable and connecting hardware must meet minimum standards, as specified in the IEEE 802.3 standard. The default settings for 10BASE-T network links in the LT 8000 Series testers reflect those standards.

10BASE-T systems use the 1 and 2 pins for transmit, and the 3 and 6 pins for receive, as shown in the following figure. The instrument passes or fails the Wire Map based on this pin configuration. If your system does not use the IEEE 802.3 wiring standard, a custom adapter is required to align nonstandard transmit and receive pairs.

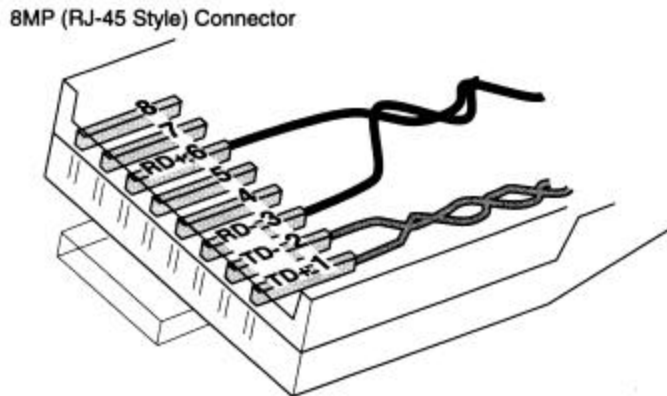

**Figure 4-5: 10BASE-T Connector**

*Note: Other pairs may be wired but 10BASE-T uses only the pairs shown.*

## Testing and Troubleshooting Token Ring Cabling

Token Ring Cabling uses two-pair cable and connectors, shielded and unshielded, for network data transmission. The cable and connectors for Shielded Token Ring systems are very different from those used in 10BASE-T and Structured Wiring Systems. The default settings for each type of Token Ring network in the LT 8000 Series testers are based on maximums for cable and connectors listed in the IEEE 802.5 standard.

The LT 8000 Series testers require the use of special adapters for connection to IBM Universal Data Connectors (UDC) or Enhanced Data Connector (EDC). The adapter test leads, (LT8IBM), are shown attached to the Display and Remote Handsets in the figure below.

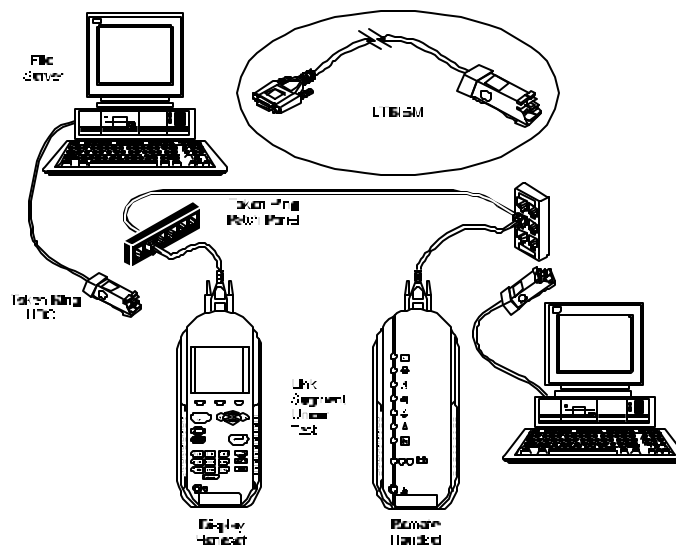

**Figure 4-6: Token Ring Test Connections**

When connected to a properly wired Token Ring network link, the adapters will return the proper Wire Map. The instrument uses the 3,6 and 4,5 pairs to map the two-pair system. When selecting Token Ring cable, be sure to select shielded or unshielded to ensure the parameters are correct. If a shielded system is being tested, Wire Map will also show the shield continuity.

## Testing and Troubleshooting with Special Adapters

### Testing with 110 Connecting Block Adapters

At times, it is necessary to test directly from a 110 connecting block to either a patch panel or office outlet. There are two types of 110 adapters that can be used with the LT 8000 Series testers:

- All WWG supported adapters allow testing up to 155 MHz
- A commercially available 8MJ (RJ-45 Style) to 110 block adapter can be used to support testing requirements up to 20 MHz (Category 4).

Use a T568A or T568B adapter test lead to replace one of the test leads supplied with the LT 8000 Series tester. Usually this test lead is connected to the Display Handset. However if required, it can be connected to the Remote Handset. Connect the other handset using one of the test leads supplied with your tester.

*Note: Observe the Wire Map results on the first test carefully. If the Wire Map fails, it may indicate a reversal between T568A and T568B wiring standards. Try replacing the adapter test lead with the opposite lead and the link should map correctly.*

### Testing with Patch Cable Adapters

The test leads supplied with the instrument are designed for the most common testing requirement, installed building cables.

- The WWG Basic Link test cord (Model LT8BASIC) is designed to exceed TIA/EIA Category 5 ISO 11801 specifications, and is specifically designed with a Low-Crosstalk male connector for direct connection to the Display and Remote Handsets. The other end of the test cord has an 8MP (RJ-45 style) plug for connecting to network patch panels and wall outlets.
- The WWG Channel Adapter (Model LT8CHANNEL) is specifically designed with a Low-Crosstalk jack for direct connection to the network patch and equipment cords.

## **Testing with Custom Made Adapters**

Occasionally, testing is required on cable systems that are wired differently than the popular pairing configurations standardized by TIA/EIA's T568A or T568B. Special adapters can be made if they are not commercially available.

All cables and components in a custom test adapter should equal or exceed the minimum standards for the link they test. If you attempt to test a Category 5 link with a custom adapter containing a Category 4 plug or cable, it will cause failures. Even if the link passes the Category 5 testing, the readings will not be representative of the actual link quality.

The LT 8000 Series tests twisted pair cable in specific pairing. When using an adapter, be sure the alignment is correct. Compare the wiring schemes for T568A or B and USOC, as shown below:

<b>T568A or B Pairs</b>	<b>USOC Pairs</b>
1,2	1,8
3,6	3,6
4,5	4,5
7,8	2,7

Test results for the 3,6 and 4,5 pairs will be normal, but USOC's 1,8 and 2,7 will be out-of-limit since the pair alignment is incorrect. It should be noted that if only the 3,6 and 4,5 pairs are tested, and the connectors are 8MJ (RJ-45 style), no adapter is required. Use the test leads supplied with the instrument.

Please call WWG Applications support (*see Appendix B, Customer Support*) if you need help when fabricating custom adapters.

## Patch Cable Testing

Patch cable connectors will wear out from over-insertions. RJ-45 connecting hardware is limited to 500-1000 mating cycles before requiring replacement.

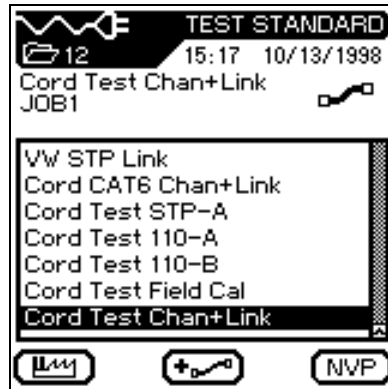





Figure 4-7: Cord Test Options

### To perform a Cord Test on Channel and Link Adapters:

1. Connect the DH and RH together using a Basic Link adapter connected to a Channel Link adapter.
2. Press the  soft key. The tester will display the Cable Type screen.
3. Position the cursor bar on **Misc. Types**, and press the  key to open the Test Standard screen.
4. Position the cursor bar on **Cord Test Chan+Link**, and press the  key to change the test standard.
5. Press the **Autotest**  key to perform the Cord Test.

*Note: Perform the test on both sets of Channel and Basic Link Adapters.*

### Contents

- Setting up Autotest preference
- How to run an Autotest function
- Viewing and interpreting Autotest results

### Autotest Overview

Autotest is the easiest and quickest way to measure and verify your cable installation. When the Autotest key is pressed, the LT 8000 Series tester automatically performs a series of pre-programmed tests. These test suites are pre-determined based on either adopted or proposed standards as well as specific parameters. After all tests have been completed, the tester displays a single overall pass/fail result and individual test pass/fail results.

Autotests are performed with the Display Handset (DH) and Remote Handset (RH) connected at opposite ends of the cable under test.

### Test Suites

The tests run during an Autotest depend on the cable type selected (*refer to Chapter 3, Selecting a Cable Type*). Autotest can be preset to automatically save test results immediately following each suite of tests, or results can be saved and printed manually. To preset these functions, see *Autotest Preferences, page 5-8*, in this chapter. Individual sub-tests can be selected and viewed with more detailed data following completion of the Autotest using the Autotest Results screen.

**Chapter 5  
Autotesting**

**Table 5-1: Preset Autotest Suites Available for Specific Cable Types**

CABLE TYPES	Wire Map	Resistance	Length	Attenuation	NEXT	Capacitance	ELFEXT	Return Loss	Impedance	Delay & Skew	ACR	PS NEXT	PS ELFEXT	PS ACR	Headroom
<b>TWISTED PAIR</b>															
CAT 3, UTP (TIA/EIA568A & TSB67 - Channel)	-		-	-	-										
CAT 5, UTP/STP (TIA/EIA568A & TSB67 - Basic/Channel)	-		-	-	-										
CAT 5 Gbit, UTP/STP (TIA/EIA568A & TSB95 - Basic/Channel)	-		-	-	-		-	-		-					
CAT 5e, UTP/STP (TIA/EIA568A & TSB67 - Basic/Channel)	-	-	-	-	-	-	-	-	-	-	-	-	-	-	-
CAT 6, UTP/STP (Draft 5 Proposal) (TIA/EIA568A & TSB67, Basic/Channel)	-	-	-	-	-	-	-	-	-	-	-	-	-	-	-
ISO Class C, UTP/STP (ISO 11801 - Basic/Channel)	-	-	-	-	-	-		-	-	-	-				
ISO Class D, UTP/STP (ISO 11801 - Basic/Channel)	-	-	-	-	-	-		-	-	-	-				
ISO Class D 120, UTP/STP (ISO 11801 - Basic/Channel)	-	-	-	-	-	-		-	-	-	-				
ISO Class D, UTP/STP (Proposal) (Basic/Channel)	-	-	-	-	-	-		-	-	-	-				
ISO Class D 120, UTP/STP (Proposal) (Basic/Channel)	-	-	-	-	-	-		-	-	-	-				
ISO Class E, UTP/STP (Basic/Channel)	-	-	-	-	-	-	-	-	-	-	-	-	-	-	-
TP-DDI, STP (Basic/Channel)	-	-	-	-	-	-		-	-	-	-				
BOSS, STP (Basic/Channel)	-	-	-	-	-	-		-	-	-	-				
BOSS 120, STP (Basic/Channel)	-	-	-	-	-	-		-	-	-	-				
TPPMD, UTP (Channel)	-	-	-	-	-	-		-	-	-	-				
AS/NZS C, UTP/STP (Basic/Channel)	-	-	-	-	-	-		-	-	-	-				
AS/NZS D, UTP/STP (Basic/Channel)	-	-	-	-	-	-		-	-	-	-				

*(Table Continues)*

**Table 5-1: Preset Autotest Suites Available for Specific Cable Types (Continued)**

CABLE TYPES	Wire Map	Resistance	Length	Attenuation	NEXT	Capacitance	ELFEXT	Return Loss	Impedance	Delay & Skew	ACR	PS NEXT	PS ELFEXT	PS ACR	Headroom
<b>ETHERNET</b>															
10BASET (IEEE 802.3)	.	.	.	.	.	.									
10BASE2 (IEEE 802.3)		.	.	.											
10BASE5 (IEEE 802.3)		.	.	.											
<b>TOKEN RING</b>															
4MB, UTP/STP (IEEE 802.5)	.	.	.	.	.	.									
16MB, UTP/STP (IEEE 802.5)	.	.	.	.	.	.									
Enhanced A, STP (IEEE 802.5)	.	.	.	.	.	.									
<b>MISC. TYPES</b>															
Local Talk	.	.	.	.		.									
ISDN	.	.	.	.	.	.					.				
DIN 44312-1	.	.	.	.	.	.		.	.	.	.				
Bavaria STP (Basic/Channel)	.	.	.	.	.	.		.	.	.	.				
AUTOMATCH	.	.	.	.	.	.		.	.	.	.				
ECOMATCH	.	.	.	.	.	.		.	.	.	.				
FOILTEK	.	.	.	.	.	.		.	.	.	.				
PAIRTEK	.	.	.	.	.	.		.	.	.	.				
Single Pair	.	.	.			.					.				
USOC	.	.	.	.	.	.					.				
IBM Coax		.	.	.											
Twinaxial		.	.	.											
Arcnet		.	.	.											
CATV		.	.	.											
<b>FIBER</b>	(Please refer to the FiberKit+ User Manual for more information)														

## **Chapter 5**

### **Autotesting**

---

*Note: For a detailed test description, refer to Chapter 4 LT 8000 Series Cable Testing Fundamentals.*

## Test Setup

1. If the LT 8000 Series tester has not been calibrated in the past 24 hours, perform a field calibration (*See Chapter 3, Calibrating the Tester*).
2. Configure the tester as required (*See Chapter 3, Configuring the Tester*):
  - Enter User Information
  - Set Autotest Preferences
  - Adjust Display Contrast
  - Set Time-out Options
  - Set Measurement Units
  - Configure the PC and Printer I/F
  - Configure the Talkset Option
  - Set Date & Time
  - Select Display Language
  - Restore Factory Defaults

*Note: The tester retains the last configuration settings. You only need to set configuration options if one or more parameters have changed.*

3. Select the Cable Type (*See Chapter 3, Selecting a Cable Type*).
4. Disconnect the cable to be tested from all network equipment.
5. Connect the Basic Link or Channel Adapters to both handsets.
6. Connect the Display Handset test lead to one end of the link and the Remote Handset lead to the opposite end (*See Chapter 4, Basic and Channel Link Test Setup*)

*Note: LT 8000 Series test leads come with a male connector on one end and an RJ-45-style, 110 block or other standard network connector on the opposite end. (For a complete list of standard and optional accessories, refer to Appendix A).*

7. Power up the Display Handset by pressing the **On/Off** key.

*Note: The Remote Handset will be powered up automatically by the Display Handset when the Autotest initiates.*



## Test Sequence

When the **Autotest** button  is pressed, the following actions occur:

1. The DH will first attempt to communicate with the RH (Remote Handset) using one correctly wired pair. If it is unable to establish communication, the DH will display a message that it is looking for the RH and continue trying until the Autotest is manually canceled or the RH is found.
2. Once communication with the RH is established, its serial number is checked to see if current field calibration data exists. If a field calibration has not been performed in the last 24 hours with this RH, the Autotest will be aborted and a Calibration Required message will display.
3. If the serial number is valid, the DH will proceed with the specified Autotest. The first test performed in most Autotests is the Wire Map for twisted pair cable types.
4. After running the Wire Map test, Autotest runs the remaining tests specified for the currently selected cable type. You have the option of specifying (in Autotest Preferences) that testing halt after any failed test or proceed through the entire Autotest regardless of test failures.

*Note: All tests after Wire Map will only be performed on valid wire pairs.*

5. Once an Autotest has been completed, all of the test data can be reviewed, saved, and printed.
  - The test results for the last Autotest are held in non-volatile memory and available for review or storage, even after power is cycled off and back on.
  - The last Autotest results remain in non-volatile memory until replaced by new test results or memory is cleared.

## Autotest Preferences



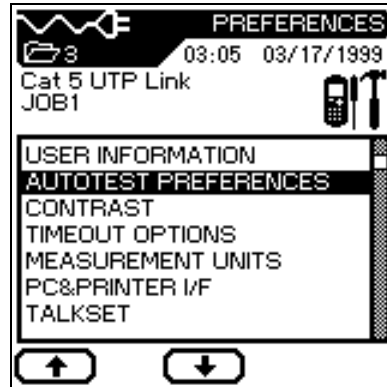

### Setting your Autotest Preference Options

1. Select the **Preferences**  Icon. The Preferences screen appears

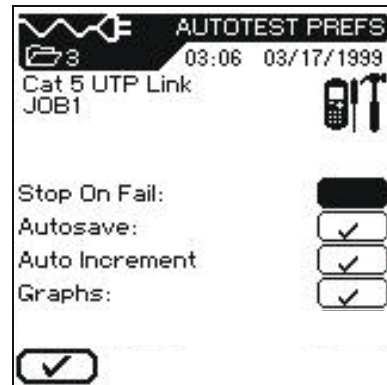

2. Select the **Autotest Preferences** option. The Autotest Preference screen appears.





3. Press the **Arrow** keys or use the **Page Up**  and **Page Down**  soft keys to position the cursor next to the desired option.
4. Press  to select or deselect an option.
5. Press **Enter**  to accept the selected Autotest Preferences.

## Running Autotest

Autotest performs comprehensive tests to measure cabling using programmed testing limits. An overall pass or fail is displayed along with individual test results.



Before beginning Autotesting, connect the tester Display and Remote handsets to the cable or link to be tested.

1. Press the **Autotest** key .
2. If the RH unit is not found, a Searching for Remote Handset warning message is displayed on the DH.

Press  to cancel the test and return to the Ready screen.

3. If the RH is found, Autotest compares the cable test readings to standards for the cable type selected and issues pass/fail statements for each test.
4. While Autotest is in progress, a circular timer displays test progress and indicates pass or fail for each completed test.

*Note: Press and hold Stop/Cancel  prior to Autotest completion to stop Autotest after completion of the test in progress.*

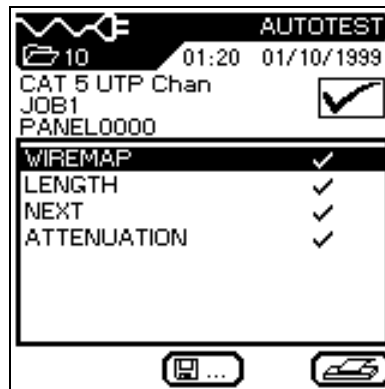

5. When the Autotest is completed, an overall result of pass  or fail  is displayed at the top right of the test information columns.

Results for individual tests are displayed opposite each test name.



## Chapter 5 Autotesting

---

6. To begin the next Autotest, press **Autotest** .
7. If results from the current test have not been printed, or you did not have AutoSave enabled in the Autotest Preference screen, you will be prompted to discard  or save  the current test results before the next Autotest will run.



*Note: The tester also performs real time Analyze testing that enables the user to troubleshoot problem areas. If Autotest results indicate a failure, see Chapter 6 to use Analyze Testing.*

## Interpreting Autotest Results

### Pass/Fail Reporting

The overall Autotest result is displayed below the Title Bar at the top right of the Autotest display screen. Individual Autotest results are displayed to the right of each test.

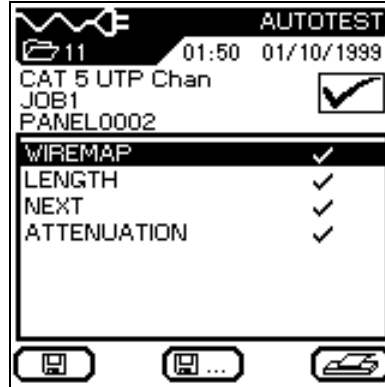

**Table 5-2: Overall Test Result Symbols**

Symbol	Overall Autotest Result
	Overall test result is a <i>pass</i> if each individual test is a <i>pass</i> or a <i>pass</i> *
	Overall test result is a <i>fail</i> if one or more individual test is either a <i>fail</i> or a <i>fail</i> *

**Table 5-3: Individual Autotest Reports**

Symbol	Individual Autotest Result
	<i>Pass</i> All values pass with sufficient margin.
	<i>Pass</i> * All values pass, but one or more test values passed by a margin smaller than the unit's specified accuracy for the measurement. The <i>pass</i> * result does not fail the cable. However, it is a warning that the cable is close to the limit on that parameter and should be inspected as soon as possible.

(Table Continues)

Table 5-3: Individual Autotest Reports (Continued)

Symbol	Individual Autotest Result
✘	<i>Fail</i> One or more values fail by a significant margin.
✘✱	<i>Fail*</i> One or more values fail, but the margin of failure is smaller than the unit's specified accuracy for the measurement. The <i>fail*</i> result fails the cable and must be cleared up, just like a standard fail. However, <i>fail*</i> means it has failed by a small margin and minor adjustments in the installation may correct the error.

The effect of the *pass\*/fail\** reporting of individual test results is to provide a built-in margin of safety above and below the advertised accuracy for a measurement. Measurements which fall outside this guard band are a clear *pass* or a clear *fail*, and the probability of the tester being in error is negligibly small.

## Viewing Current Autotest Results

Autotest results can be viewed at the completion of the test sequence or saved for later viewing.

1. Use the **Arrow** keys to position the cursor bar on the desired test.



2. Press **Enter**  to view test results.

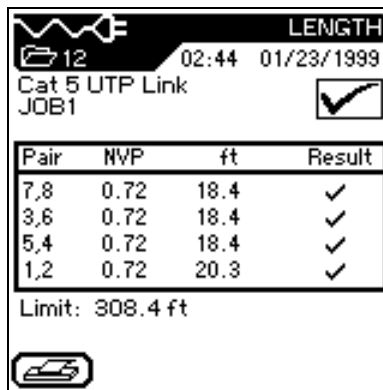

3. When finished, press  to return to the Autotest screen.

## **Understanding Test Failures**

A failure result for Autotest indicates that one or more tests did not meet minimum cable parameter levels for the cable type selected.

*Note: Be sure that you have selected the correct cable type and are using appropriate connectors and links.*

Identifying which tests failed and the characteristics of the failure will determine the type of fault. If the Autotest shows a failure on a particular sub-test, perform Analyze testing (Chapter 6) for the failing test in order to troubleshoot the cable.

When more than one test fails on Autotest, the test order used for troubleshooting is an important element in eliminating the source of the problem.

If any tests fail, Analyze tests should be run in the following order:

1. Wire Map
2. DC Resistance
3. Length
4. Delay and Skew
5. Impedance
6. Attenuation
7. NEXT
8. Dual Return loss



Refer to Chapter 6 to run these tests in Analyze mode.

## Using Jobs to Store Test Results



The LT 8000 Series tester gives you the ability to store cable test results under separate Job names. You can create Jobs, assign any name to them, and store test results on a Job by Job basis. By using Jobs, you can logically group and store test results in a descriptive manner.

You can set up a separate Job for each floor in a building, each building on a campus, each customer, or for any other classification.

### To create a New Job,

1. Select the **Stored Results**  icon and press **Enter** . At this point, you will see a list of all the jobs which are currently available. If you have never created a Job, the list will be empty.



2. To create a new Job press the options  button. The **Job Options** screen appears. Select **New Job** and press **Enter** .



## Chapter 5 Autotesting

---

3. Type a name into the text field on the **New Job** screen using the alphanumeric keyboard. You will need to press a key two or three times to get the second and third character on the key.

Press the right arrow hard key to advance to the next character position.



*Note:* Press  to delete a highlighted character.

4. When you have entered the name, press . You will return to the Job Options screen where you can Access Job information, Delete Jobs, Rename Jobs, make a Job the current Job, or create more Jobs.

*Note:* When you save test results, they will be stored in the last Job you made current.

## Saving Current Autotest Results

A maximum of 1,500 (LT 8155, LT 8600) TIA Cat 5 individual Autotest results can be stored in the LT 8000 Series tester memory and accessed later using the Test Results menu.

Autotest results can be saved immediately following the test.

- Only overall passed Autotests are automatically saved.
- The entire set of test results is saved as one file.
- Test results are automatically saved if the AutoSave preference is enabled. Refer to *Setting Autotest Preferences, page 5-8*.
- Test names are automatically assigned to completed tests. If a different name is desired, a test can be named manually using **Save As** . Refer to Step 4, below.



### To save Autotest results (AutoSave Disabled):

1. To manually save an Autotest, press the  key.
2. The Test Saved screen will be displayed for a brief period, showing the name the test is saved under.
3. If the current name already exists, the following Warning screen appears.



## Chapter 5 Autotesting

---

4. Press  to Escape and return to the previous screen without performing a save operation, or Press  to Overwrite the existing file.
5. Press  to select the **Save As** option to rename the current test. The **Save Test** screen will display with a new name option.

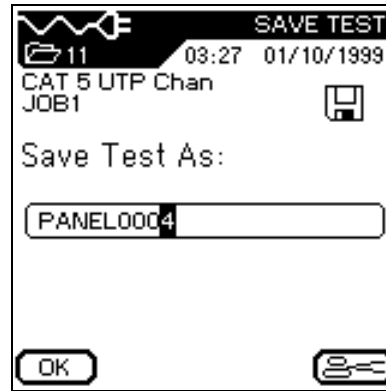

*Note: The default Save As name is derived from the cable name entered into the Cable ID screen , or from the previous saved name.*

## Printing Current Test Results

Printing can be done from a test results screen or from stored Autotest results. Once a serial printer is connected to the DH, test results are printed by pressing the Print  key. The tester does not perform batch printing.

*Note: The Print  key can also be used to upload the test data to a PC communication program (i.e. Hyper Terminal)*

## Connecting a Serial Printer

1. Connect a serial printer to the tester's DB-9 serial port (RS 232) and verify the following printer settings (parallel printers will not function with tester):
  - Baud Rate: 9600
  - Data Bits: 8
  - Stop Bit: 1
  - Parity: None
  - Flow Control: XON/XOFF
2. From the Ready screen, select the **Preferences**  icon to open the Preferences screen.

## Chapter 5 Autotesting

---

3. In the Preferences screen, use the **Arrow** keys to select the PC & Printer I/F option.

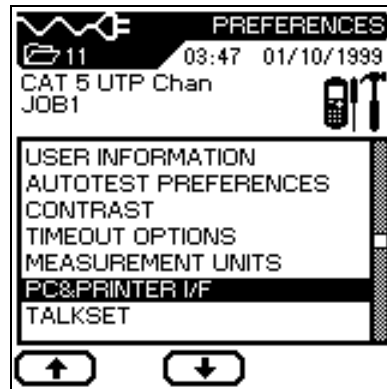

4. In the **PC & Printer I/F** screen, set the correct printer parameters.

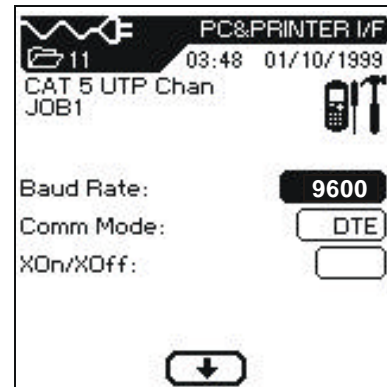

5. Press **Enter** (↵) to save changes.
6. Press (⏪) to return to the previous screen after setting the printer communication settings.



### If the printer does not respond, check the following:

- Printer indicates “On-Line.”
- Printer parameters have been correctly set.
- Correct serial cable is securely fastened to the printer and the DH.





## Viewing or Deleting Stored Autotest Results

Test Results contain stored data from Autotest. On the LT 8000 Series tester up to 1,500 Autotests can be stored in memory. Users can view, print, delete or rename these files.

When an Autotest or an individual test from Analyze is saved, the data is stored with a unique name. Test results can be viewed, printed, or deleted from the Stored Results screen.



1. Select the **Test Record**  icon to open the **Job List** screen.
2. Position the highlighted cursor over the desired Job.
  - Press  to select multiple items for processing.

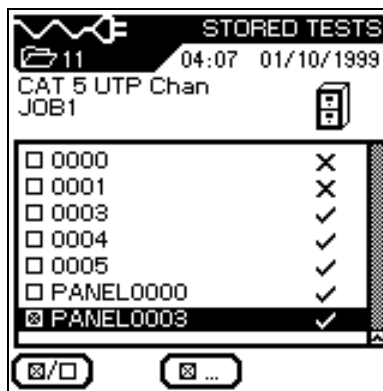

3. Press **Enter**  or the **Check Box**  to select the job for viewing. The **Stored Results** screen opens.
  - Press  to select multiple items for processing.
4. Repeat step 3 as many times as necessary.
5. Press  to open the **Options** screen.



## Chapter 5 Autotesting

6. Position the highlighted cursor over the desired option. In this example, the marked job is to be deleted from memory.
7. Press **Enter**  to perform the desired option.
8. Press **Escape**  at any time to return to the previous screen.

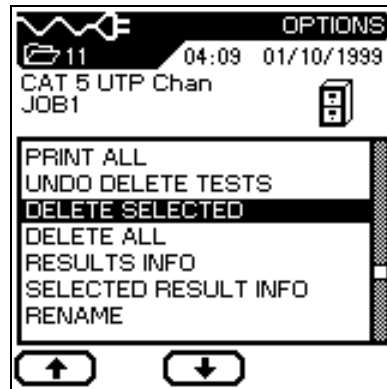

### Job and Test Option Tables

**Table 5-4: Job Options**

Option	Description
Current Job Info	Total number of tests passed/failed, cable length, and headroom for <i>current</i> job
All Job Info	Total number of tests passed/failed, cable length, and headroom for <i>all</i> jobs.
Delete Selected Jobs	Deletes selected jobs from memory.
Rename	Change name of currently selected job.
New Job	Add new job to job list.
Make Job Current	Activates highlighted job. Saved tests (Autotests/Analyze) will be stored in this test.
Undo Delete Jobs	Undo last delete action.

**Table 5-5: Test Options**

*Note: The functions indicated below will only be performed on tests stored in memory.*

<b>Option</b>	<b>Description</b>
Select All	Select all stored test results.
Select All Passed	Select only passed test for processing.
Select By Date	Select stored test results by date.
Select All Failed	Select only failed tests for processing.
De-select All	Unmark all stored test results.
Print Selected	Print selected test results.
Print All	Print a summary of stored test results.
Undo Deleted Tests	Undo the last delete action.
Delete Selected	Delete marked test results.
Delete All	Delete all stored test results.
Result Info	Displays test result information such as number of tests, number passed and failed, length tested, and headroom.
Selected Result Info	Display the results of selected tests.
Rename	Rename a selected test result.

## Autotest Graphs

Autotest results can be viewed at the completion of the test sequence in either a tabular or graphical format.

**Tabular Format**

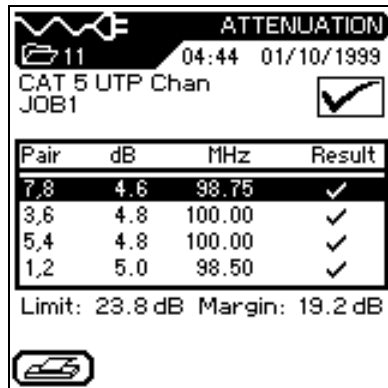

**Graphical Format**

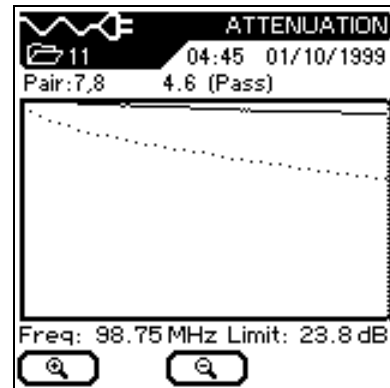

## Graphing Facts

Graphs can be very useful for viewing test results. There are a few things you need to know before you start using them:

1. In order to view test graphs, graphs must be enabled from the Autotest preferences screen *before* running Autotest.
2. Graphs are *not stored* in flash ROM with the test results.
3. Once you save a test result or run another Autotest, the currently displayed graph is permanently erased from the graph memory buffer.
4. The Limit and worst case Margin parameters are always displayed at the bottom of the Tubular test screen.
5. When you go to graph view, the vertical cursor is always placed at the worst case Margin location.

**To view an Autotest graph:**

1. Configure the Autotest Preferences. Refer to this chapter, pages 5-8.
2. In Autotest Preferences, make sure the **Graphs** checkbox is selected.

3. Press the **Autotest**  button.  
Upon completion of the test suite for the cable type selected, the Overall Autotest results screen displays.

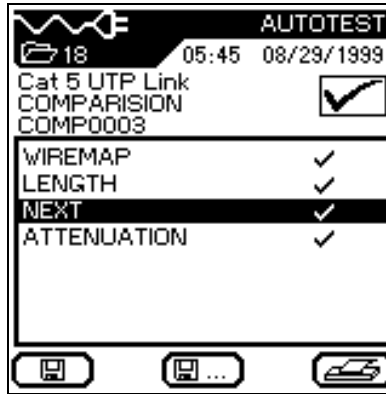

4. To display tabular data, position the cursor on the desired test result (the NEXT test) and press **Enter**.

5. To display a graph of the tabular data, position the cursor on the tabular data of interest (pairs 7,8 and 3,6) and press **Enter**.





## Chapter 5 Autotesting

---

- The graph will always open with the cursor positioned on the worst case margin. In this example, the cursor is positioned on the horizontal axis at 74.75 MHz.

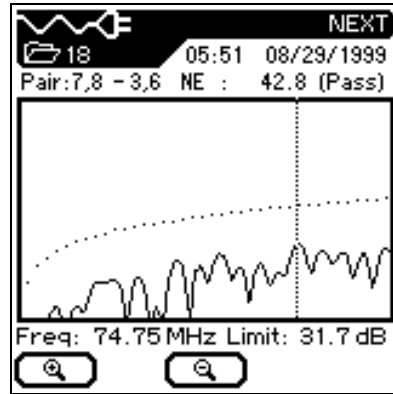
*Note: Graphs can only be displayed; they cannot be saved in memory.*



- Press  to return to the previous screen.

## Graph Formats, Layouts, and Controls

### Formats

There are two different graph formats, single and dual plot. For an example of each format, refer to the following graphs.

Single Plot

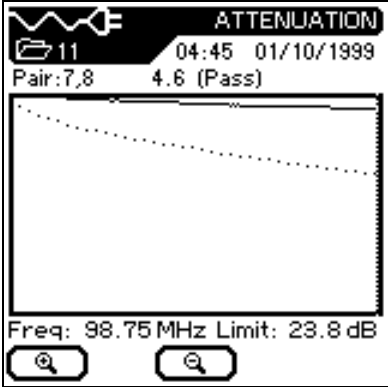

Dual Plot

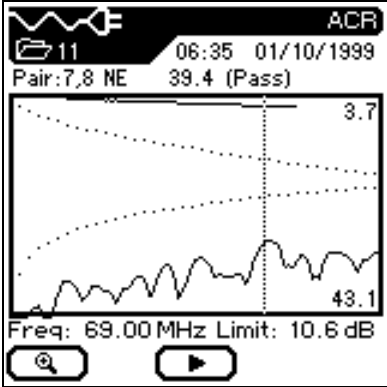

**Layout and Controls**

Graphs are useful for observing the relationship between two network cable parameters, actual measured parameters and predefined worst case margins. The coordinate system of the graph is formed by horizontal and vertical axes. The horizontal axis represents frequency data and the vertical axis represents the measure values in dB, with limits indicated as a dotted trace.

**Tabular View**

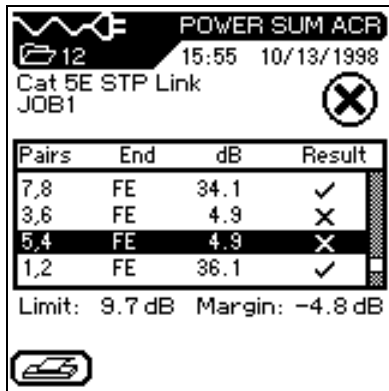

**Graphical View**

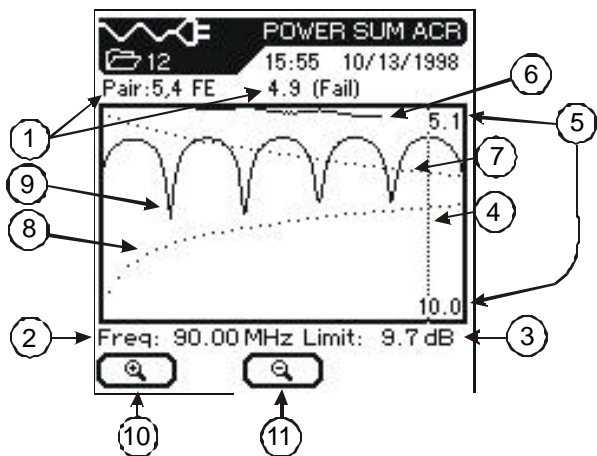

**Figure 5-1: Tabular Data and Graphical Plot Layout**

*Note: The Margin data at the bottom right of the Tabular screen represents the worst case difference between the actual measured data and the predefined limit threshold as shown by the cursor position in the graph on the right.*

**Table 5-6: Autotest Graph View Layout and Controls**

<b>Point</b>	<b>Function</b>
1	Wire Pair plotted from tabular data.
2	The horizontal axis represents frequency data.
3	The vertical axis is tracked by the cursor. The result represents measurements in dB.
4	When a wire pair graph is first displayed, the cursor is automatically positioned at the worst case limit and frequency point from the preceding tabular data.
5	Cursor values for each curve are displayed in the top right and bottom right corners of the graph. The values will change as the cursor is moved.
6	Actual data plot for a wire pair. Attenuation is plotted in this example.
7	Predefined worst case limit plot for attenuation.
8	Predefined worst case limit plot for NEXT.
9	Actual data plot for a wire pair. NEXT is plotted in this example.
10	Expands the horizontal axis of the graph about the cursor. Repeated operation of this key will repeatedly scale the graph. At full magnification, this key becomes inactive.
11	Compresses the horizontal axis of the graph about the cursor. Repeated operation of this key will repeatedly scale the graph. When the full graph is displayed, this key becomes inactive.
Left/Right Arrow Keys	Used to move the cursor horizontally. As the cursor moves, screen readouts will change to reflect cursor position.
Up/Down Arrows Keys	Used to scroll through the pair or pair combinations from the tabular test results screen and display plot data. Repeated up/down operations will cycle through the results list and cause a wraparound.



# Chapter 6

## Analyze Testing

---

### Contents

- How to run tests in the Analyze single test mode
- Setting up test preference
- Viewing and interpreting Analyze test results

### Analyze Single Test Mode Overview

Analyze mode allows you to troubleshoot by running individual tests, making adjustments, and observing changed test results. For example, a failed capacitance measurement can indicate crimped or stretched cable. With Analyze testing, you can walk the cable and check for damage and stretching. Freeing the cable at suspected problem areas should improve the measured reading.

Depending on the cable type and defined test standard, any or all of the following individual tests are available:

- Wire Map
- DC Resistance
- Capacitance
- Length
- Return Loss
- ACR
- NEXT
- Delay and Skew
- Headroom
- Attenuation
- Impedance
- ELFEXT
- Power Sum NEXT
- Power Sum ACR
- Power Sum ELFEXT

## **Analyze Test Descriptions and Availability**

For an overview of individual tests, refer to *Chapter 4, LT 8000 Series Cable Testing Fundamentals*. The individual tests you can run depend upon the cable being tested. Test availability is pre-determined based on the adopted or proposed standards, refer to *Chapter 5, Test Suites, Table 5-1*.

### **Test Setup**

1. If the LT 8000 Series tester has not been calibrated in the past 24 hours, perform a field calibration (See Chapter 3, *Calibrating the Tester*).

2. Configure the tester as required (See Chapter 3, *Configuring the Tester*):

*Note: The tester retains the last configuration settings. You only need to set configuration options if one or more parameters have changed.*

3. Select the Cable Type (See Chapter 3, *Selecting a Cable Type*).

4. Disconnect the cable to be tested from all network equipment.

5. Connect the test leads to both the Display and Remote Handsets using the connectors.

*Note: LT 8000 Series test leads come with a male connector on one end and an RJ-45-style, 110 block or other standard network connector on the opposite end. (For a complete list of standard and optional accessories, refer to Appendix D).*

6. Connect the Display Handset test lead to one end of the link and the Remote Handset lead to the opposite end.

*Note: Refer to Chapter 4, Figures 4-3 and 4-4, for connections to complete Basic and Channel Link testing.*

7. Power up the Display Handset by pressing the **On/Off** key.



*Note: The Remote Handset will be powered up automatically by the Display Handset when the Analyze testing initiates.*

## Test Sequence

When an individual test is run, the following actions occur:

1. If the test requires the RH (Remote Handset), the DH will first attempt to communicate with the RH. If it is unable to establish communication, the DH will display a message that it is looking for the RH and continue trying until the Analyze test is manually canceled or the RH is found.
2. Once communication with the RH is established, its serial number is checked to see if current field calibration data exists. If a field calibration has not been performed in the last 24 hours with this RH, the test will be aborted and an appropriate Calibration Required message will display.
3. If the serial number is valid, the DH will proceed with the specified individual test.
4. If the test does not require the RH, the DH will run the test and display test data.
5. Once a test is run, the test data can be reviewed or printed.

## Analyze Test Screens

There are a total of 15 Analyze test screens. They are identical to the corresponding Autotest screens, with the addition of the **Run**  key to the soft key option row. When this key is pressed, the tester begins continuous execution of the selected test. The **Halt**  key is used to end the test in progress.

## Analyze Test Limitations

Analyze and Autotest test limitations are identical. For a description of test limits and ranges refer to *Appendix C, Measurement Methods and Limits*.

## Running a Single Test

Before beginning Analyze testing, connect the Model LT 8000 Series Display and Remote Handsets to the cable or link to be tested.

All Analyze tests are run using the following procedure:



1. In the **Ready** screen, select the **Analyze**  icon to open the Analyze screen. The Analyze screen lists the tests that can be performed on the currently selected cable type (refer to *Chapter 3, Selecting a Cable Type*).

2. Use the **Arrow** keys to position the cursor bar on the desired test.

In this example, the **Length** test is selected.

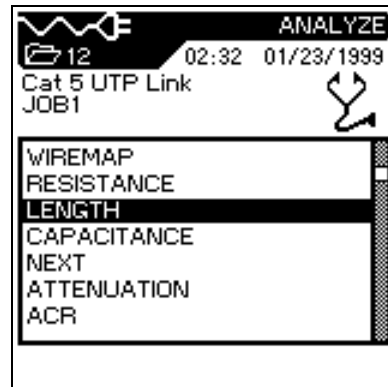
3. Press  to start the test.



4. Upon test completion, the tabular results screen is displayed.
5. Press  to run the test in continuous mode. Press and hold  to end continuous mode testing.

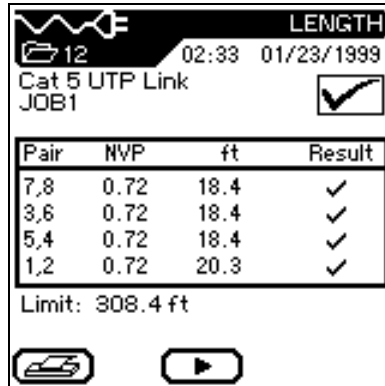

Pair	NVP	ft	Result
7,8	0.72	18.4	✓
3,6	0.72	18.4	✓
5,4	0.72	18.4	✓
1,2	0.72	20.3	✓

Limit: 308.4 ft

## Interpreting Analyze Test Results

### Pass/Fail Reporting

The overall Analyze test result is displayed below the Title Bar at the top right of the display screen.

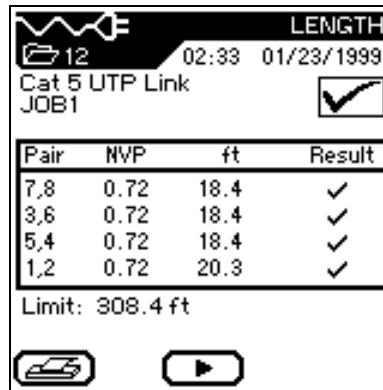

Individual wire pair test results are displayed to the right of each test.



Pair	NVP	ft	Result
7,8	0.72	18.4	✓
3,6	0.72	18.4	✓
5,4	0.72	18.4	✓
1,2	0.72	20.3	✓

Limit: 308.4 ft

In the example above, the Length test results screen is displayed.

- Individual wire pair test results are displayed in the last column on the right (Result column).
- An overall test result of pass  or fail  is displayed at the top right above the Result column.

Overall and Individual test result reporting is usually identical to Autotest mode. For a description of symbols and test results, refer to *Chapter 5, Pass/Fail Reporting*.

## **Printing Analyze Test Results**

A Tabular test result screen can be sent directly to a serial printer. Before sending a result screen to the printer, the printer port needs to be configured. For detailed printer setup and screen printing instructions, refer to *Chapter 5, Printing Current Test Results*.

## **Analyze Graphs**

Certain Analyze test results can be viewed at the completion of the test sequence in either a table or graphical format.

1. Run an Analyze test.
2. Position the highlighted cursor on the desired table data.
3. Press the **Enter** key to display the wire pair table data as a graph.

Analyze graphs are similar to Autotest graphs. For a description of these graphs, refer to *Chapter 5, Graph Formats, Layout, and Controls*.

# Chapter 7

## Using LT Record Manager Software

---

### Contents

- LT Record Manager software installation, startup, and user interface
- LT Records Manager Help system overview
- Software configuration and options
- Importing Autotest data from the tester into a PC database
- Viewing and printing test reports

### System Requirements

Your PC should have the following capability:

Minimum:	486DX-33, 8 MB RAM, 10 MB Free Disk Space, Windows 95.
Recommended:	Pentium 90 MHz, 16 MB RAM, 100 MB Free Disk Space, Windows 98 and 95, or Windows NT version 4.0 or greater.

## LT Record Manager Installation, Startup, and Navigation

### LT Record Manager (LTRM) Upgrades

The CD that came with your tester may not contain the latest version of the LTRM program. WWG provides a World Wide Web (WWW) site for LAN cable test products that allows you to use a PC and modem to obtain the latest LTRM maintenance release. Refer to *Appendix B, World Wide Web*.

### Installation Procedure

The LT Record Manager software is installed using the standard Windows 95 program installer.

1. Insert the LT Record Manager CD-ROM.
2. Click on the Start button, and then click Run.
3. Type, d:\ setup

*Note: If your CD-ROM drive is not the "d" drive, replace "d" with the correct drive letter.*

4. Follow the instructions on your screen.

*Note: Install LT Record Manager in the default directory, c:\lrm.  
An empty database will be created in c:\lrm\db.*

### Starting the LT Record Manager Program

Do one of the following:

- From the Windows desktop, click on the Start button. Next, click on Programs, LT Record Manager, LT Record Manager.

- From Windows Explorer, go to the ltrm folder and double-click on the LTRM application file.
- Click the Start button and then the Run command, type c:\ltrm\ltrm.

## Tester to PC Connectivity

### PC Cable

Use the cable supplied with your Tester (commonly referred to as a Null modem cable), to upload test results to a PC. If you supply your own cable, it must be wired to the following specifications.

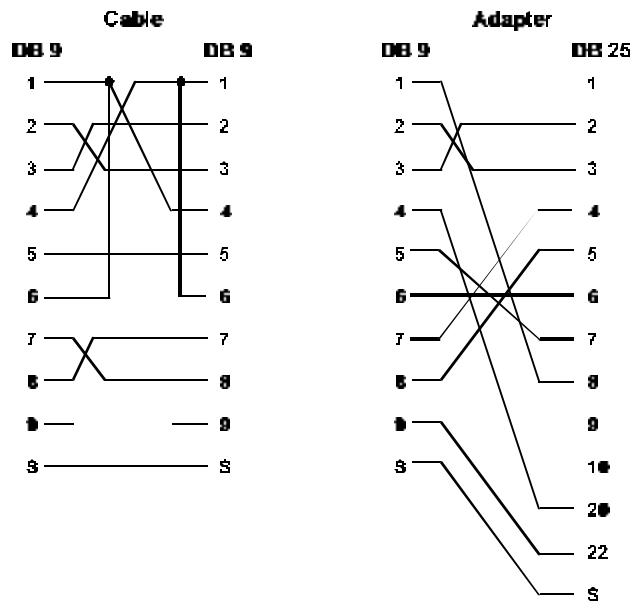

**Figure 7-1: PC Uploading Cable Pinout**

## Establishing a Connection

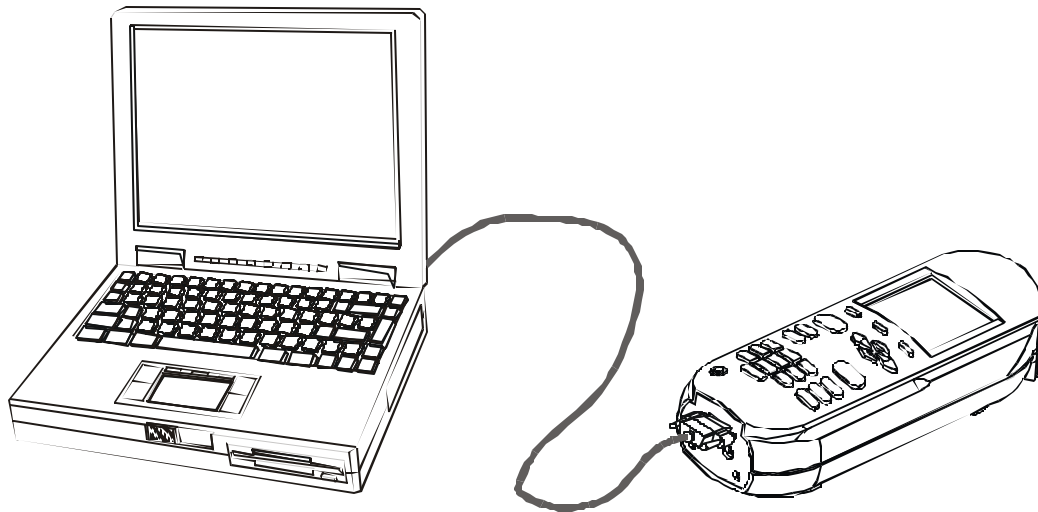
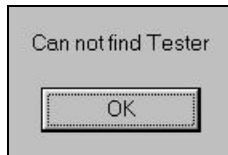

**Figure 7-2: PC/Tester Connection**

1. Attach the cable to the tester and an available serial port on the PC or Laptop.
2. Turn on the tester.
3. Start the LT Record Manager program on the PC or Laptop.
4. From the LT Record Manager **Options** menu, select the **Tester ID** command.

The program will automatically scan the available communications ports and baud rates to locate and identify an attached Tester. If the tester is not identified, proceed to the next step.

5. Some PCs may have difficulties with this function and the following dialog box displays. Click on the **OK** button.



6. Click on the **Options** menu, select the **Serial Port** command. Select the correct **Port** and match the **Baud Rate** to that of your LT 8000 Series tester.
7. After you have entered the values, click the **Test** button.
  - If the Tester is identified, its serial and model numbers will be displayed.
  - If you have tried alternative baud rates and ports and LT Record Manager still cannot find the Tester, call Wavetek Customer Support.
7. Click on the **OK** button.



## The File menu

Click on File to display the File pull-down menu. Many of the selections on this menu are standard Windows options.

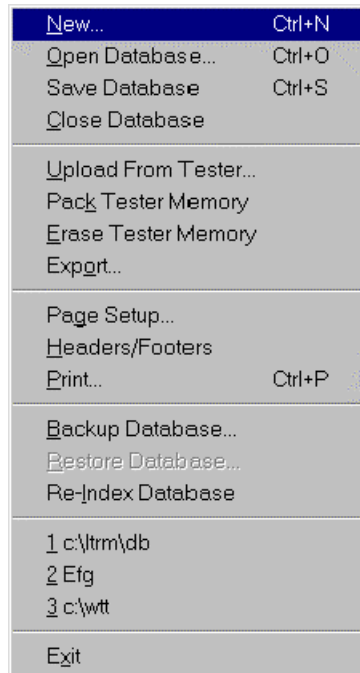

Command	Description
New	Create a new database.
Open Database	Open an existing database. More than one database can be open at the same time.
Save Database	Save the currently open database
Close Database	Close the currently open database.
Upload From Tester	Pull result data from the LT 8000 Series tester.
Pack Tester Memory	Erase all tests in the tester memory that are marked for deletion.

## Chapter 7

### Using LT Record Manager Software

---

<b>Command</b>	<b>Description</b>
Erase Tester Memory	Erase all test in the tester memory.
Export	Export test results as Comma-Separated Values (CSV) or standard ASCII text files.
Page Setup	Modify the print settings.
Headers and Footers	Insert notes.
Print	Print a report.
Backup Database	Archive current data in the current folder.
Restore Database	Restore a closed database from a zipped archive file into the current folder.
Re-Index Database	Re-index the database
Switch To	Switch to one of the last three most recently accessed databases.
Exit	Exit the application.

## The Edit Menu

Click on Edit to display the Edit pull-down menus.

### Job View



Command	Description
Add Job	Add a Job.
Edit Job	Modify a Job.
Delete	Delete a job from the database.
Paste	Copy the clipboard contents to the currently selected item.
Upload From Tester	Upload a job from the tester to the PC.
Pack Tester Memory	Erase all tests in the tester memory that are marked for deletion.
Erase Tester Memory	Erase all test in the tester memory.
Export	Export test results as Comma-Separated Values (CSV) or standard ASCII text files.
Select Job	Select an item in the database view in preparation for printing or reporting.

**Chapter 7**  
**Using LT Record Manager Software**

---

<b>Command</b>	<b>Description</b>
Select All	Select all entries in the database view.
Find Job...	Locate a database item.

**Database (Test) View**

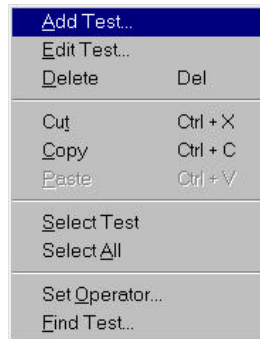

<b>Command</b>	<b>Description</b>
Add Test	Add a Test.
Edit Test	Modify a Test.
Delete	Delete a test from the database.
Cut	Cut the currently selected test(s).
Copy	Copy the currently selected tests to the clipboard.
Paste	Copy the clipboard contents to the currently selected item.
Select Test	Select a test in the database view for printing or reporting.
Select All	Select all tests in the job.
Set Operator	Provide details of the operator for the currently selected test.
Find Test	Locate a database test item.

## The View Menu

The View pull-down menu allows you to hide or display the toolbar or status bar and view



While in database (test) view, select a test and click on the Test Information option to open the Test Information window. A red dot on a test tab indicates one or more tests on the tab failed. A green dot indicates that all tests on the tab passed. Click on a test tab to display stored test results.

The screenshot shows a window titled 'Cable:TEST0000 (907)'. At the top, there are input fields for Job Name (ADG), Date (4/12/99), Operator (OPERATOR NAME), Customer, Test Instrument (LT8600 [0/0]), Test Standard (Custom), Freq. Range (1-300 MHz), and NVP (All 0.72). Below these are several test tabs: Power Sum ACR, Power Sum ELFEXT, Power Sum NEXT, ELFEXT, Wiremap, Pair Data, Return Loss (selected), NEXT, Attenuation, and ACR. The Return Loss tab is active, displaying a table of test results.

Pairs	NE/FE	Result	Worst	Limit	Margin
7,8	NE	Fail*	13.4 dB @ 147.50MHz	> 13.5 dB	-0.1 dB
3,6	NE	Fail	9.8 dB @ 140.00MHz	> 13.7 dB	-3.9 dB
5,4	NE	Fail*	11.0 dB @ 275.50MHz	> 11.5 dB	-0.5 dB
1,2	NE	Pass	18.5 dB @ 270.50MHz	> 11.6 dB	6.9 dB
7,8	NE	Fail*	12.5 dB @ 140.00MHz	> 13.7 dB	-1.2 dB
3,6	NE	Fail	7.8 dB @ 281.00MHz	> 11.5 dB	-3.7 dB
5,4	FE	Fail*	9.7 dB @ 285.50MHz	> 11.4 dB	-1.7 dB
1,2	FE	Pass	16.5 dB @ 271.00MHz	> 11.6 dB	4.9 dB

## The Options Menu

Click on Options to display the Options pull-down menu.

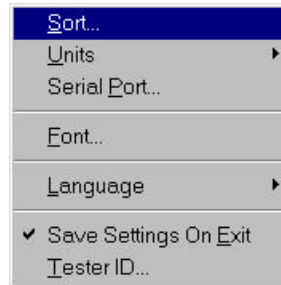

Refer to page 7-19 for a description of the Option menu.

## The Help Menu

This menu provides the standard windows Help support, and displays the About dialog.

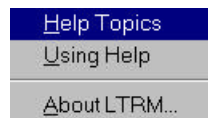

## The Status Bar



The Status Bar at the bottom of the screen lists the functions that are currently operating and indicates the number of tests residing in the currently highlighted job.



## The Toolbar

The tools on the toolbar are shortcuts for commands you otherwise access with menu commands.

### Tool Button Identification

	New		Upload
	Open		Get Tester ID
	Cut		Set Operator
	Copy		Backup
	Paste		Select All
	Delete Selected		Sort
	Export		Find
	Import		Help
	Print		About

## The Right Mouse Button

The right mouse button provides another shortcut to some of the more commonly used functions from the Edit menu. This feature is context sensitive; it supports different functions depending on where you utilize it.

## LT Records Manager Help System Overview

You gain access to the LTRM Help system by using the Help menu command.

### Help Topic Menu Option

The Help Topics menu option is the primary way to gain access to the LTRM Help system.

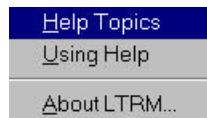

### To open the Help System

1. Pull down the **H**elp menu and click the **H**elp Topics command. The Help Topics screen displays.

### Help Topics Screen

The LTRM **H**elp Topics screen contains three tabs and three buttons.

## Content Tab

The **Content** tab displays a list of topics in the LTRM Help system; it is organized by category.

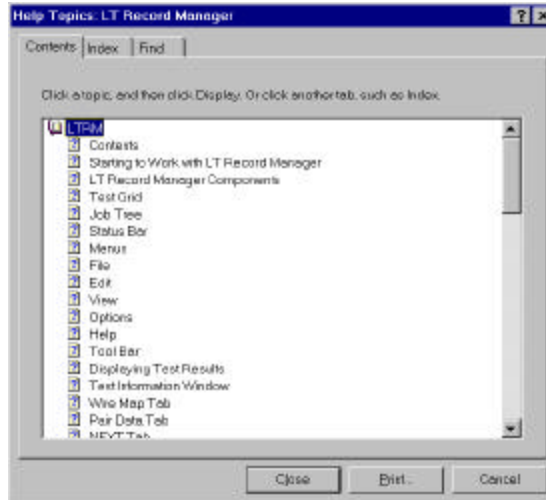

## Index Tab

The **Index** tab is similar to a traditional book index, listing keywords and phrases alphabetically.

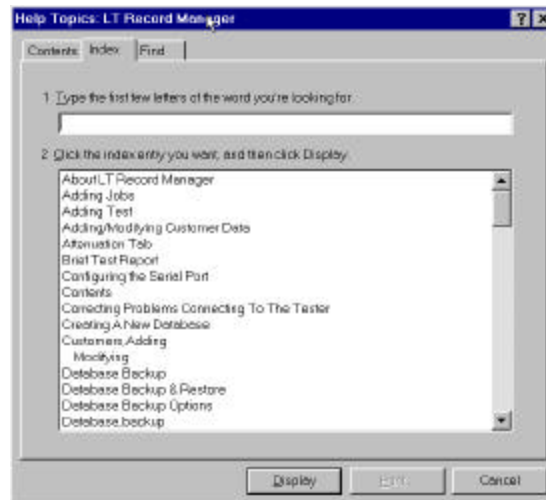

**Find Tab**

The **F**ind tab provides functionality for a full-text search for any word or phrase in the Help system.

**D**isplay Button

The **D**isplay button “opens” the selected LTRM Help item.

**P**rint Button

The **P**rint button prints the selected item.

**C**ancel Button

The **C**ancel button closes the LTRM Help system

## Using Help Screen

The Using Help screen is arranged similar to the Help Topics screen. It also contains three tabs and 3 buttons. The screen contains instructions for using and customizing the LTRM Help system.

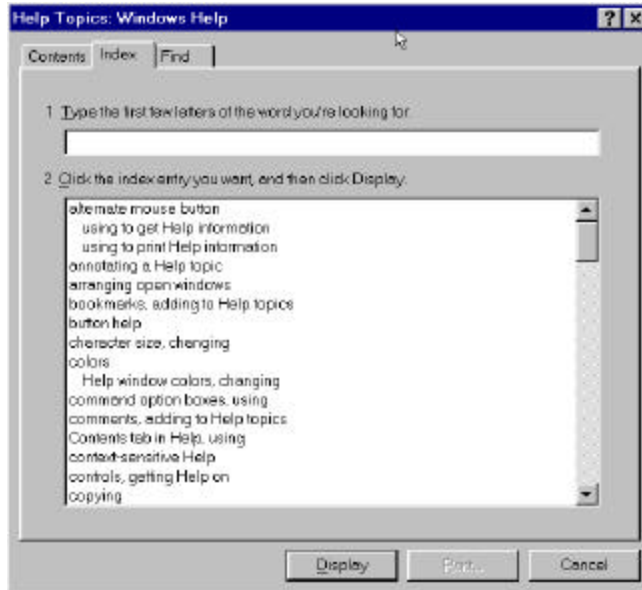

## About LTRM Screen

The About LTRM screen displays the LTRM version number running on your computer.



## Program Configuration

Use the Options pull-down menu to configure the LT Records Manager program to match your hardware and user preferences.

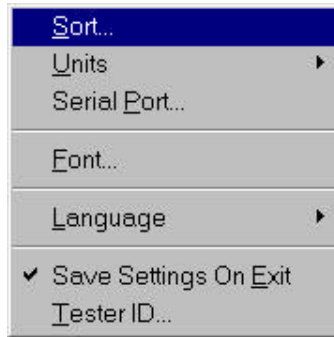

**Table 7-1: Options Pull-Down Menu**

Command	Description
<u>S</u> ort	Sort tests in the database view.
<u>U</u> nits	Choose feet or meters as the measurement units for both the screen display and printouts.
Serial <u>P</u> ort	Configure the serial port for your LT 8000 Series tester.
<u>F</u> ont	Change the screen display font.
<u>L</u> anguage	Change the language for both the screen display and printouts.
Save Settings On <u>E</u> xit	Save and use the current hardware and user preferences the next time the program is started.
<u>T</u> ester ID	Locate and identify an attached tester.

## Working with Databases

On start-up, the database that was opened last will automatically reload.

*Note: The first startup of LT Record Manager will load an 'empty' database (c:\lrm\db) from the database directory.*

## Creating a New Database

1. Pull down the **F**ile menu and click the **N**ew command.

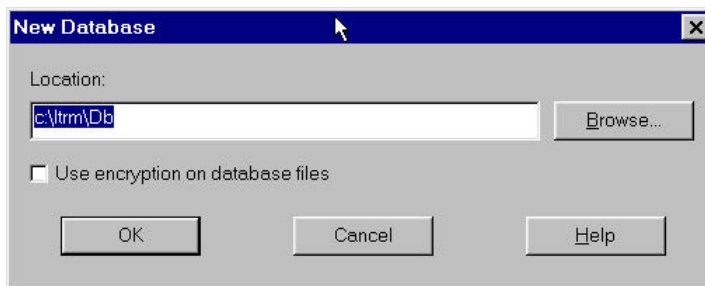

2. You can either type the new path and database name or choose **B**rowse and select an existing path and then type in the database name.

*Note: The name of the new database displays only in the title bar of the main window.*

3. Click the **O**K button when you are finished.

## Opening an Existing Database

1. Pull down the **File** menu and select the **Open** command.

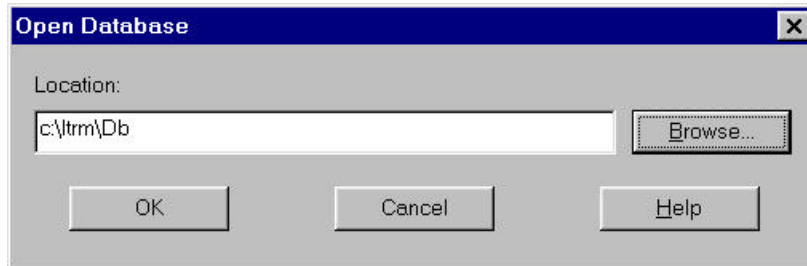

2. Type in a file path and name, or use the **Browse** button to locate the desired database folder and file.
3. Click the **OK** button to open the database.

*Note: The name of the open database displays in the title bar of the main window only.*

## Working at the Job Level

### Navigating the Job Tree

Tests are stored in folders called Jobs. For example, each floor of a building can be listed as a separate Job. Another Job can represent the entire building or just those tests conducted by a particular technician.

The left side of the Database View shows the hierarchy of Jobs. Clicking on a Job folder that is preceded by a plus (+) sign reveals the Jobs it contains. This hierarchy can be up to five levels deep.

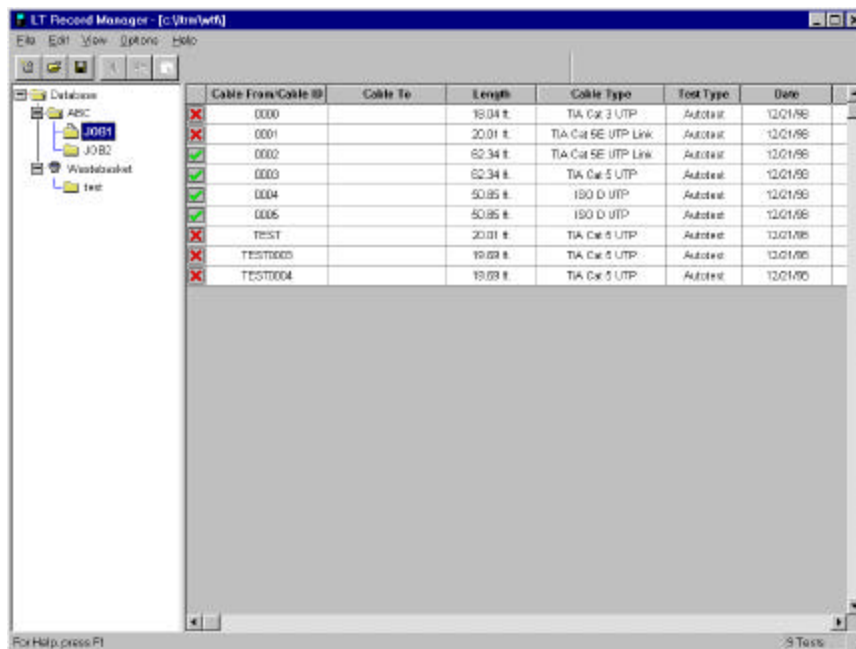

- Jobs that have attached test records are indicated by a  icon. When you click on this icon, the test records become visible.
- You may move Jobs by selecting and dragging them. Selection is indicated by a highlight bar.

## Adding a Job

You must click on the left side of the main database view for the Add or Edit Job functions to be available. You can create a new collection of tests by adding a Job folder.

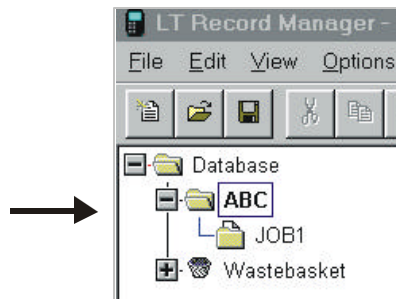

1. From the **E**dit menu, click **A**dd Job. The Add Job dialog box displays.

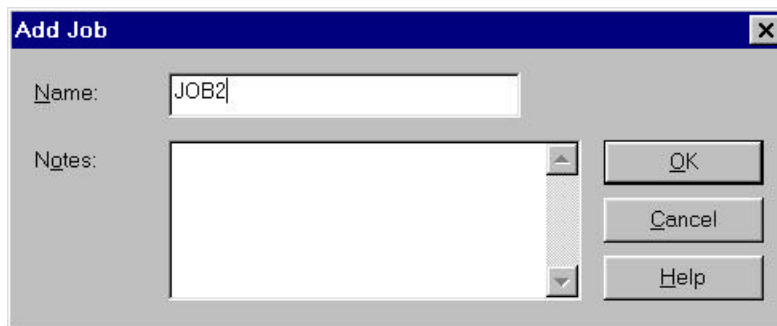

2. Type in a name for the Job folder and any notes you want to add.
3. Click **OK** to create the new job folder.

*Note: The LT 8100 does not store tests by job name. You must create a job name in the database to group the tests in a job folder.*

## Editing Job

To change the name of a Job folder or attach some textual notes:

1. From the **E**dit menu, click **E**dit Job. The Edit job dialog box appears.

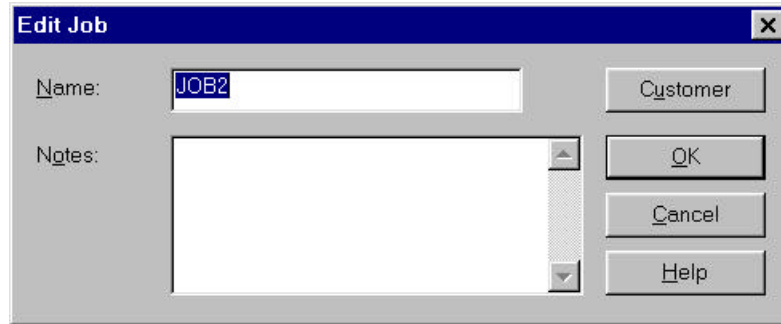

2. Click on the **N**ame or **N**ote text boxes to perform the desired edits.
3. Click **OK** when you are finished.

## Adding or Editing Customer Details

You may also want to add or modify customer details on a specific Job entry.

1. From the **E**dit menu, select the **E**dit Job command.
2. Click on the **C**ustomer button. The Add Customer or Modify Customer dialog box displays.

The image shows two side-by-side dialog boxes. The left dialog box is titled "Add Customer" and contains the following fields: Name (with a dropdown menu), Address (with a text input field), Phone (with a text input field), Fax (with a text input field), Contact Name (with a text input field), and Contact Address (with a text input field). The right dialog box is titled "Modify Customer" and contains the same fields, but with "New Client" in the Name dropdown, "New Address" in the Address field, and "New Phone" in the Phone field. Both dialog boxes have "OK", "Cancel", and "Help" buttons on the right side.

3. Add new customer information or edit existing information. If a customer name is supplied it will appear at the beginning of a report.

## Adding or Changing the Test Set Operator Name

You may add or change the operator name associated with a given test.

1. Open a job and position the cursor in the desired test field on the right side of the screen.
2. Select the **E**dit menu.
3. Click on the **C**ustomer button. The Set Operator dialog box displays.

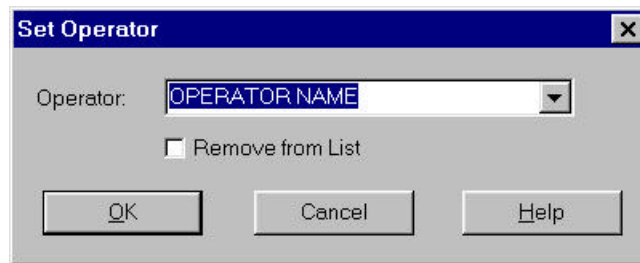

4. Click on the **D**rop-down Arrow for a list of all operators.
5. Select an operator from the drop-down list or enter a new operator name.
6. Click **O**K when you are finished.

## Finding a Job or Test

The Find function searches for Job Names, Cable IDs and Tests. You can control both the type of match and the direction of the search.

1. Before opening the Find dialog box:
  - Click on a **folder** at the Job level at the left side of the main database screen to find a job.
  - Click on a **test** in the test grid on the left side of the main database screen to find a test.
2. Select the **E**dit menu.
3. Click on the **F**ind Job or **F**ind Test commands. The Find dialog box displays.

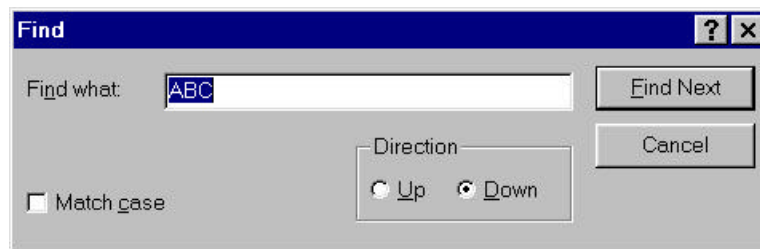









4. Enter the job name, then specify the find criteria using the **M**atch case of text and **D**irection to search buttons.
5. Click on the **F**ind Next button.
6. Click the **C**ancel button when you are done searching.

## Working at the Test Level

### Displaying the Test Grid

1. Click on a Job folder that contains tests, as indicated by a  icon.
2. A list of test records will appear in the right side of the Database View. This is referred to as the Test Grid.

	Cable From/Cable ID	Cable To	Length	Cable Type	Test Type	Date	Time
	0000		18.04 ft.	TIA Cat 3 UTP	Autotest	12/21/98	18:58:24
	0001		20.01 ft.	TIA Cat 5E UTP Link	Autotest	12/21/98	18:59:43
	0002		62.34 ft.	TIA Cat 5E UTP Link	Autotest	12/21/98	19:01:12
	0003		62.34 ft.	TIA Cat 5 UTP	Autotest	12/21/98	19:01:32
	0004		50.85 ft.	ISO D UTP	Autotest	12/21/98	19:03:00
	0005		50.85 ft.	ISO D UTP	Autotest	12/21/98	19:05:50
	TEST		20.01 ft.	TIA Cat 5 UTP	Autotest	12/21/98	18:56:24
	TEST0003		19.69 ft.	TIA Cat 5 UTP	Autotest	12/21/98	18:38:59

## Viewing Test Details

1. Click on a Job folder that contains tests, as indicated by a  icon.
2. Double-click on any test entry in the test grid (left side of the main database screen) or hold down the Ctrl key and type “V”. Depending on the type of cable, you will see individual tabs for each test.
3. Click on the Tab for the test results that you want to view.

Wiremap	Pair Data	NEXT	Attenuation			
Pair#	NE/FE	Result	Worst	Limit	Margin	
7,8-3,6	NE	Pass	50.9 dB @ 16.00MHz	> 21.0 dB	29.9 dB	
7,8-5,4	NE	Pass	59.5 dB @ 8.20MHz	> 25.8 dB	33.7 dB	
7,8-1,2	NE	Pass	63.2 dB @ 15.70MHz	> 21.3 dB	41.9 dB	
3,6-5,4	NE	<b>Fail</b>	16.1 dB @ 2.50MHz	> 35.5 dB	-19.4 dB	
3,6-1,2	NE	Pass	50.9 dB @ 16.00MHz	> 21.0 dB	29.9 dB	
5,4-1,2	NE	Pass	62.5 dB @ 6.25MHz	> 28.1 dB	34.4 dB	
7,8-3,6	FE	Pass	51.9 dB @ 15.85MHz	> 21.2 dB	30.7 dB	
7,8-5,4	FE	Pass	58.1 dB @ 6.70MHz	> 27.8 dB	30.5 dB	
7,8-1,2	FE	Pass	64.2 dB @ 15.85MHz	> 21.2 dB	43.0 dB	
3,6-5,4	FE	<b>Fail</b>	16.1 dB @ 2.50MHz	> 35.5 dB	-19.4 dB	
3,6-1,2	FE	Pass	52.0 dB @ 16.00MHz	> 21.0 dB	31.0 dB	
5,4-1,2	FE	Pass	62.8 dB @ 6.70MHz	> 27.8 dB	35.2 dB	

## Moving Tests Between Jobs

Tests may be selected and dragged into different Job folders.

1. Click on a test (or a range of tests) to select it.

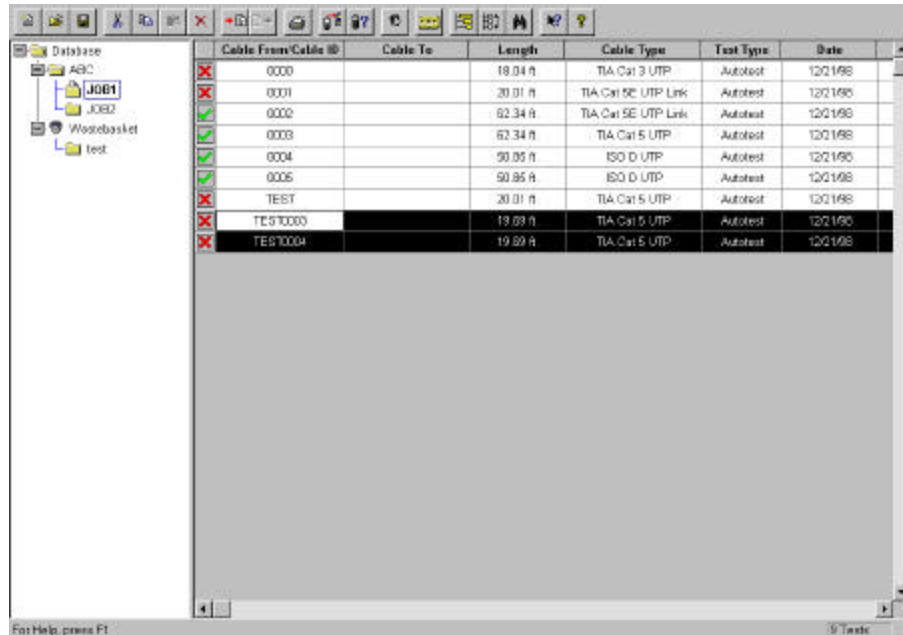

2. Move the cursor to the bottom of the highlighted area. The cursor will turn into a rectangle.
3. Click and hold the **left mouse** button while you drag the test into a new Job folder on the left side of the screen.
4. Release the mouse.

## Adding and Editing Tests

These functions become available on the Edit menu when a test record is selected. They can also be accessed by using the right mouse button.

The Find function searches for Job Names, Cable IDs and Tests. You can control both the type of match and the direction of the search.

1. Before opening the Edit menu:
  - Click on a **folder** at the Job level at the left side of the main database screen to find a job.
  - Click on a **test** in the test grid on the left side of the main database screen to find a test.
2. Select the **E**dit menu.
3. Click on the **Add Test** or **Edit Test** command. The Add or Edit Test dialog box displays.
4. Enter the cable ID in the text box labeled “From”. Enter the destination of the cable in the text box labeled “To.”



5. Enter data into the **F**rom, **T**o, and **N**otes text boxes.
6. Click on the **O**K button.

## Sorting the Tests

The Sort function allows you to reorganize tests in the Database view. You may Sort by Result, Cable ID, Cable Origin, Cable Destination, Cable Type, Test Type, Date, and Time. The easiest way to sort is to click on a column title. You sort by ascending, descending or natural order. The Sort function can be found on the Options menu and is available when one or more tests are selected.

1. On the **Options** menu, click **Sort**.
2. Click the **down arrows** next to each field and choose from the sorting options that are displayed.
3. Click **OK** to begin the sort.

You can sort tests according to three different values, with highest sort criteria listed first, followed by the second, and then the least significant sort criteria.

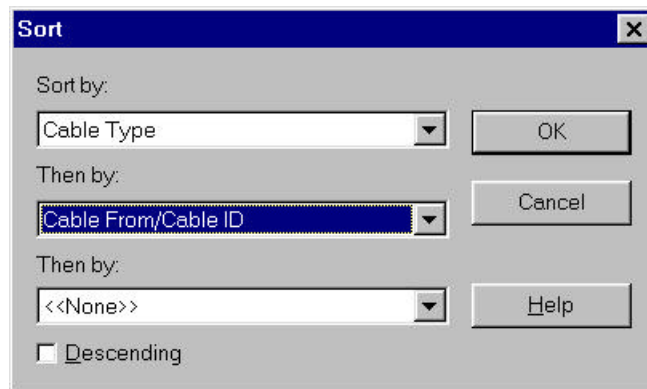

4. Sorting can also be accomplished by clicking on column headers.

## Finding Data

The Find function searches for Job Names, Cable IDs and Tests.

The Find function can be found on the Edit menu. It is context sensitive, and is available only when you have an item in the Test grid selected.

You can control both the type of match and the direction of the search. For example, if you are searching for a Test, you should have an item on the Test level of the hierarchy selected before bringing up the Find dialog box.

1. Before opening the Edit menu:
  - Click on a **folder** at the Job level at the left side of the main database screen to find a job.
  - Click on a **test** in the test grid on the left side of the main database screen to find a test.
2. Select the **E**dit menu.
3. Click on the **F**ind **T**est command. The Find dialog box displays.

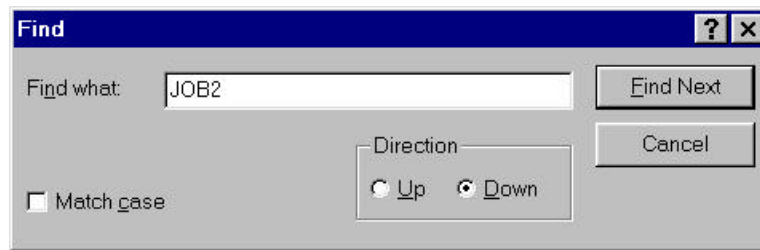

4. Enter the test name, then specify the find criteria using the **M**atch **c**ase and **D**irection buttons.
5. Click on the **F**ind **N**ext button.

## Backing Up and Restoring Databases

Regular data backups to a removable storage device are recommended. You may also restore databases to the PC from these archives.

### Backing Up a Database

This function allows you to back up a database. Following a backup, the program will compact the database and remove any deleted records.

1. Click on the **File** menu, or click on the toolbar **Backup** button.
2. Select the **Backup** command. The backup will be placed in the current folder.

### Restoring a Database

This function becomes available on the File menu only after all databases have been closed.

1. Click on the **File** menu.
2. If you have a database open, click on the **C**lose Database option and proceed to step 3. If you don't have a database open, proceed to step 4.
3. Click on the **File** menu again.
4. Select the **R**estore Database command. The backup file will be restored to the current folder.

## Uploading DH Tests to the PC

### Introduction

The LT 8155 and LT 8600 are capable of storing tests in individual job folders that can be uploaded. The LT 8100 DH is not capable of creating job folders in the DH memory. All tests are sequentially stored in base memory. To upload to a job folder on the PC, you must create a new job folder or use an existing job folder before uploading the tests.

To create a new database, refer to *Creating a New Database, page 9*. To create a new job name, refer to *Adding a Job, page 12*.

### Upload procedure

1. Designate the upload location on the PC or Laptop.

- Before uploading test data from the LT 8155 or LT 8600 DH, select a destination database in the Database View.

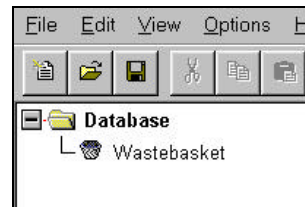

- For the LT 8100 select a destination database and job folder in the Database View.

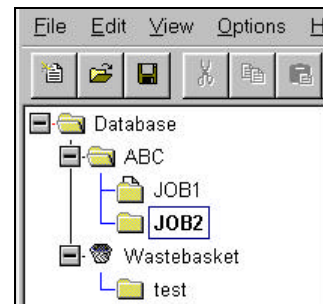

## Chapter 7

### Using LT Record Manager Software

---

- From the **File** pull-down menu, Click on the **Upload From Tester** command. The Upload dialog box displays.

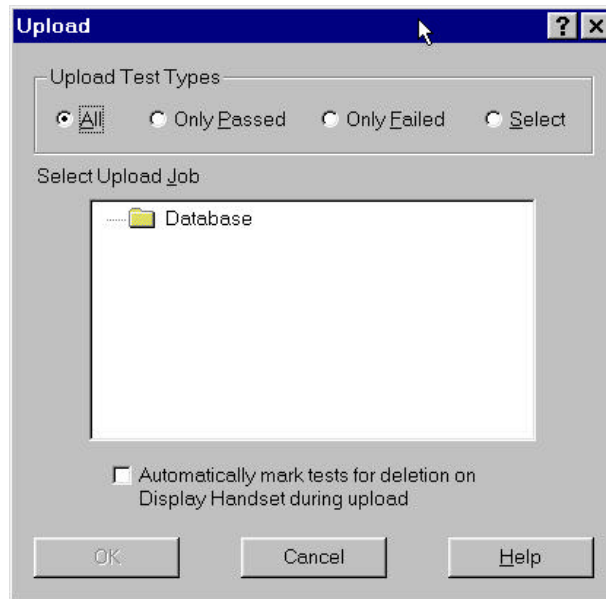

- Click on the desired **Upload Test Type** button.
- Select a job in the **Select Upload Job** text box.
- A status box will remain on screen during the uploading process and you will have the option to cancel at any time.

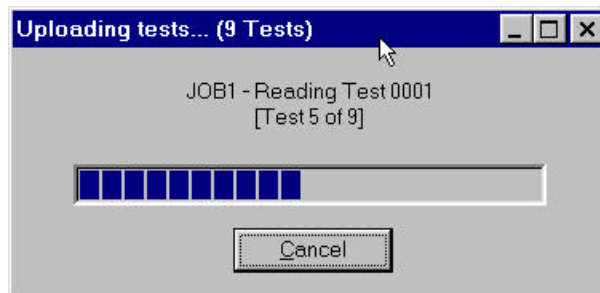

## Producing and Printing a Report

### Headers and Footers Command

Headers and footers can be added to your printed report. In a printed report, lines will separate the header and footer from the body of the report if the header or footer contain any information.

1. From the **F**ile menu, click on the **H**eaders/**F**ooters command.  
The Headers/Footers dialog box displays.

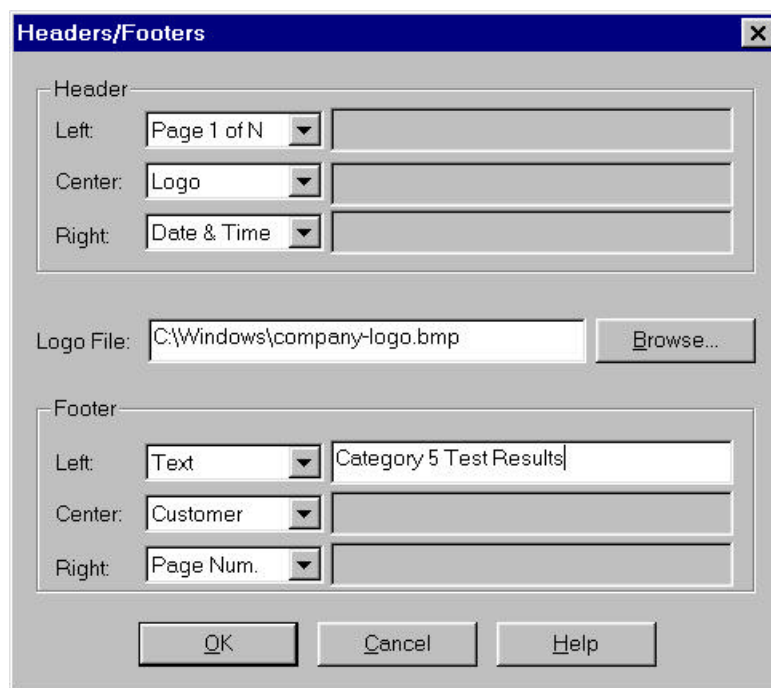

2. Decide on the position for your header or footer and click on the accompanying **Down Arrow**.

## Chapter 7

### Using LT Record Manager Software

---

3. From the selected drop-down text box, select one of the displayed options.
  - If you select **Text**, the Text Box will open. Enter your information.
  - If you select **Logo**, you must supply the location of the Bitmap file (.bmp file) to be used as the logo. You can either type the name of the file directly into the box titled “Logo File:” or use the Browse function to locate the file.
  - **Customer** is a value that is set on the Edit Job function.
4. Click on **OK**.

## Page Setup Command

Margins, paper instructions, and printer selection can be set in the Page Setup dialog box. Font style and size will be set by the program to maintain a single page per test.

1. From the **F**ile menu, Click on the **P**age **S**etup command. The Page Setup dialog box displays.
2. Set **P**aper **S**ize, **S**ource, **O**rientation, and **M**argins.
3. Click on **O**K.

*Note: You may also need to adjust the space you allocate to the header, footer, and margins in order to fit the report on one page.*

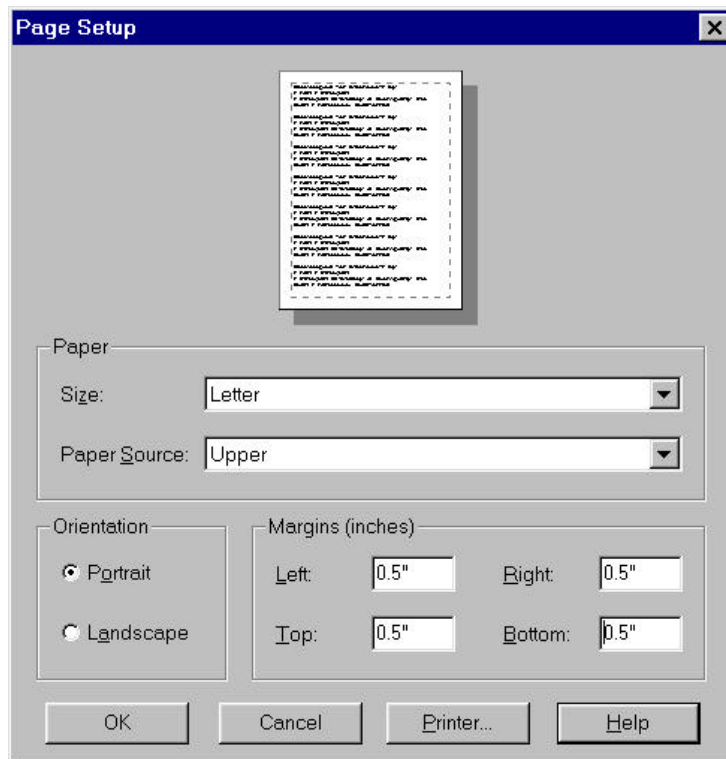

## Print Command

Printing involves two steps; selecting the printer, and specifying what you want to print.

1. From the **F**ile menu, click on the **P**rint command. The Print dialog box displays.
2. Select **Report Type**, **Printer**, **Print Range**, and number of **Copies**.
3. Click on the **Pre**view button to display your report as it will appear in print.
4. Click on **OK**.

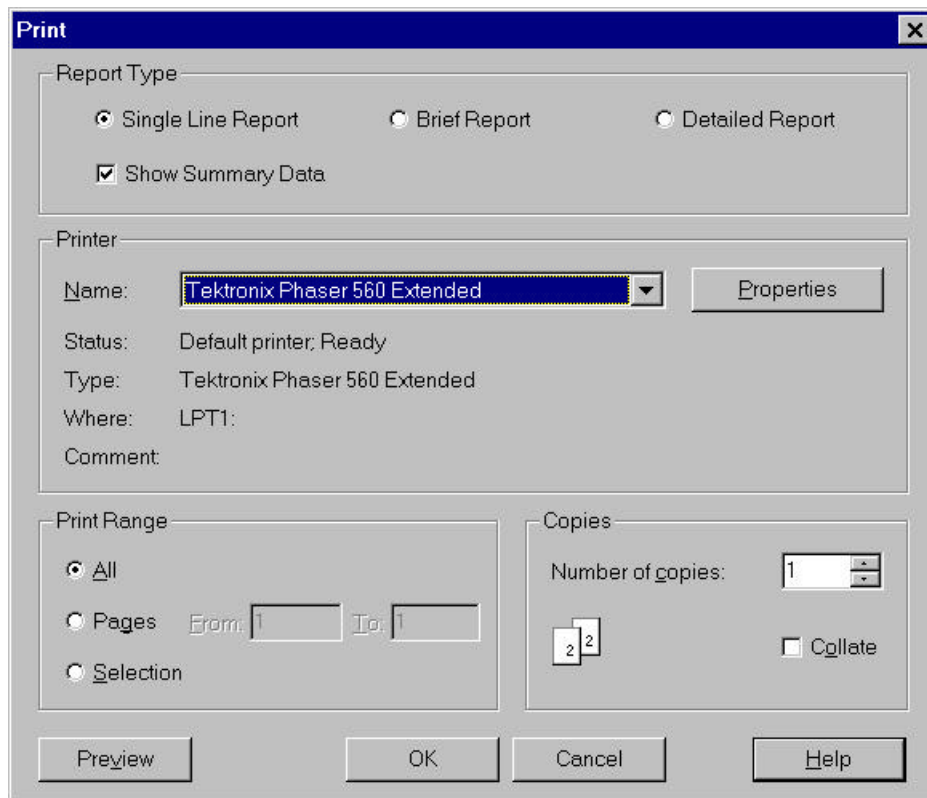

## The Single Line Report Layout

Report Type

Single Line Report     
  Brief Report     
  Detailed Report

Show Summary Data

Job Name: Headquarters		Report Date: 5/15/97			
Customer: Wavetek Corp.					
Operator: User One					
Test Instrument: W LT8XXX s/n: 1234567					
<b>Cable ID</b>	<b>Status</b>	<b>Test Date</b>	<b>Cable Type</b>	<b>Test Standard</b>	<b>Test Limit</b>
Rack1001A	Pass	5/10/97	100 Ω UTP	TIA CAT 5 Basic	100 MHz
Rack1001B	Pass*	5/10/97	100 Ω STP	TIA CAT 5 Channel	100 MHz
Rack1002A	Fail	5/10/97	100 Ω UTP	ISO Class D Basic	100 MHz
Rack1002B	Fail*	5/10/97	100 Ω STP	ISO Class D Channel	100 MHz
Rack2010A	Pass	5/11/97	150 Ω STP	TIA CAT 3 Basic	16 MHz
Riser1A	Pass	5/11/97	MM Fiber	TIA 568-A	850 nm
Bldg1to2	Fail	5/11/97	SM Fiber	TIA 568-A	1310 nm
Panel001A	Pass	5/12/97	10BASE5	IEEE 802.3	10 MHz
Panel002A	Fail	5/12/97	TWINAX	IBM	10 MHz
<b>Summary Data:</b>					
<b>All Cables</b>	<b>Twisted Pair</b>	<b>Coax/Twinax</b>	<b>Fiber</b>		
Total Tests: 9	Total: 5	Total: 2	Total: 2		
Pass: 5 (56%)	Pass: 4 (80%)	Pass: 1 (50%)	Pass: 1 (50%)		
Fail: 4 (44%)	Fail: 1 (20%)	Fail: 1 (50%)	Fail: 1 (50%)		
	Tot. Length: 1250 ft.	Tot. Length: 400 ft.			

## The Brief Report Layout

A Brief Report only includes tests that contain data.

Report Type

Single Line Report   
  **Brief Report**   
  Detailed Report

Show Summary Data

<b>PASS</b>					
Cable ID: Floor7Office1		Cable Type: 100 $\Omega$ UTP		Test Standard: Custom	
Test Date: 5/15/97		NVP: 69.0 %		Frequency Range: 1 - 100 MHz	
	<u>Result</u>	<u>Worst</u>	<u>Pair</u>	<u>Limit</u>	<u>Margin</u>
Wire Map	PASS				
Attenuation	PASS	11.5 dB	4,5	<21.6 dB	10.1 dB
Length	PASS	276 ft.	1,2	328 ft.	52 ft.
NEXT	PASS	40.1 dB @ 56.1 MHz	3,6:4,5	>33.7 dB	6.4 dB
<b>PASS</b>					
Cable ID: Floor7Office2		Cable Type: 100 $\Omega$ UTP		Test Standard: Custom	
Test Date: 5/15/97		NVP: 69.0 %		Frequency Range: 1 - 100 MHz	
	<u>Result</u>	<u>Worst</u>	<u>Pair</u>	<u>Limit</u>	<u>Margin</u>
Wire Map	PASS				
Attenuation	PASS	11.5 dB	4,5	<21.6 dB	10.1 dB
Length	276 ft.	1,2	328 ft.	52 ft.	52 ft.
NEXT	NOT PASS	40.1 dB @ 56.1 MHz	3,6:4,5	>33.7 dB	6.4 dB
Resistance	PASS	5.5 $\Omega$	7,8		
Impedance	PASS	103 $\Omega$	1,2	80 - 120 $\Omega$	
Return Loss	PASS	18.2 dB	3,6	10.0 dB	8.0 dB
Delay	PASS	800 ns	4,5	850 ns	50 ns
Delay Skew	PASS	25 ns	1,2:7,8	45 ns	20 ns
ACR	PASS	10.0 dB	1,2:3,6	10.0 dB	0 dB

## Chapter 7 Using LT Record Manager Software

<b>FAIL</b>					
Cable ID: Floor7Office3		Cable Type: 100 $\Omega$ UTP	Test Standard: Custom		
Test Date: 5/15/97		NVP: 69.0 %	Frequency Range: 1 - 100 MHz		
	<u>Result</u>	<u>Worst</u>	<u>Pair</u>	<u>Limit</u>	<u>Margin</u>
Wire Map	→FAIL		1,2		
Attenuation	PASS	11.5 dB	4,5	<21.6 dB	10.1 dB
Length	PASS	276 ft.	1,2	328 ft.	52 ft.
NEXT	→FAIL	29.5 dB @ 99.8 MHz	1,2:4,5	>33.7 dB	-----
Resistance	PASS	5.5 $\Omega$	7,8		
Impedance	PASS	105 $\Omega$	1,2	80 - 120 $\Omega$	
Return Loss	PASS	16.0 dB	3,6	10.0 dB	6.0 dB
Delay	PASS	812 ns	4,5	850 ns	38 ns
Delay Skew	PASS	27 ns	1,2:4,5	45 ns	18 ns
ACR	PASS	12.0 dB	3,6:7,8	10.0 dB	2.0 dB
<b>PASS</b>					
Cable ID: Backbone2		Cable Type: 62.5 $\mu$ Multimode Fiber	Wavelength: 850 nm		
Test Date: 5/15/97		NVP: 69.0 %			
Power Loss: 3.4 dB		Loss Budget: 5.0 dB	Reference (dBm): -20.35		

## The Detailed Layout

Report Type

Single Line Report    
  Brief Report    
  Detailed Report

Show Summary Data

**PASS**

Cable ID: Floor7Office1     Cable Type: 100  $\Omega$  UTP     Test Standard: Custom  
 Test Date: 5/15/97     NVP: 69.0 %     Frequency Range: 1 - 100 MHz

Wire Map    
 

1	2	3	4	5	6	7	8	S
								X
1	2	3	4	5	6	7	8	

**PASS or FAIL:**  
 Open/Short/Crossed Pair  
 etc.

<u>Test</u>	<u>Pair:</u> <u>1,2</u>	<u>3,6</u>	<u>4,5</u>	<u>7,8</u>	<u>Limit</u>	<u>Result</u>
Length	250 ft.	247 ft.	251 ft.	250 ft.	328 ft.	Pass
Attenuation	15.0 dB	15.5 dB	15.2 dB	15.1 dB	24.0 dB	Pass
Prop. Delay	200 ns	203 ns	204 ns	199 ns	800 ns	Pass
Delay Skew = 5 ns (Pairs 4,5 vs. 7,8)	45 ns					
Avg. Impedance	105 $\Omega$	103 $\Omega$	99 $\Omega$	101 $\Omega$	80-120 $\Omega$	Pass
Capacitance	5.5 pf	5.2 pf	5.9 pf	4.9 pf		

**NEXT: PASS**

<u>NE/FE</u>	<u>PAIRS</u>	<u>Result</u>	<u>Worst Case</u>	<u>Limit</u>	<u>Margin</u>
NE	1,2:3,6	Pass	32.6 dB @ 100 MHz	>29.3 dB	3.3 dB
NE	1,2:4,5	Pass	32.6 dB @ 100 MHz	>29.3 dB	3.3 dB
NE	1,2:7,8	Pass	32.6 dB @ 100 MHz	>29.3 dB	3.3 dB
NE	3,6:4,5	Pass	32.6 dB @ 100 MHz	>29.3 dB	3.3 dB
NE	3,6:7,8	Pass	32.6 dB @ 100 MHz	>29.3 dB	3.3 dB
NE	4,5:7,8	Pass	32.6 dB @ 100 MHz	>29.3 dB	3.3 dB
FE	1,2:3,6	Pass	32.6 dB @ 100 MHz	>29.3 dB	3.3 dB
FE	1,2:4,5	Pass	32.6 dB @ 100 MHz	>29.3 dB	3.3 dB
FE	1,2:7,8	Pass	32.6 dB @ 100 MHz	>29.3 dB	3.3 dB
FE	3,6:4,5	Pass	32.6 dB @ 100 MHz	>29.3 dB	3.3 dB
FE	3,6:7,8	Pass	32.6 dB @ 100 MHz	>29.3 dB	3.3 dB
FE	4,5:7,8	Pass	32.6 dB @ 100 MHz	>29.3 dB	3.3 dB

ACR: 17.1 dB

Headroom: 7.1 dB

**Return Loss: FAIL**

<u>NE/FE</u>	<u>PAIRS</u>	<u>Result</u>	<u>Worst Case</u>	<u>Limit</u>	<u>Margin</u>
NE	1,2	Pass	32.6 dB @ 100 MHz	>29.3 dB	3.3 dB
NE	3,6	Pass	32.6 dB @ 100 MHz	>29.3 dB	3.3 dB
NE	4,5	Fail	32.6 dB @ 100 MHz	>29.3 dB	3.3 dB
NE	7,8	Pass	32.6 dB @ 100 MHz	>29.3 dB	3.3 dB
FE	1,2	Pass	32.6 dB @ 100 MHz	>29.3 dB	3.3 dB
FE	3,6	Pass	32.6 dB @ 100 MHz	>29.3 dB	3.3 dB
FE	4,5	Pass	32.6 dB @ 100 MHz	>29.3 dB	3.3 dB
FE	7,8	Pass	32.6 dB @ 100 MHz	>29.3 dB	3.3 dB

**FAIL**

Cable ID: Floor7Office2  
Test Date: 5/15/97

Cable Type: 100 Ω UTP  
NVP: 69.0 %

Test Standard: Custom  
Frequency Range: 1 - 100 MHz

Wire Map

```

1 2 3 4 5 6 7 8 9
| | | | | X
1 2 3 4 5 6 7 8

```

**PASS** or **FAIL:**  
Open/Short/Crossed Pair etc.

## Chapter 7 Using LT Record Manager Software

<u>Test Pair:</u>	<u>1,2</u>	<u>3,6</u>	<u>4,5</u>	<u>7,8</u>	<u>Limit</u>	<u>Result</u>
Length	250 ft.	247 ft.	251 ft.	250 ft.	328 ft.	Pass
Attenuation	15.0 dB	25.3 dB	15.2 dB	15.1 dB	24.0 dB	Fail
Delay	200 ns	203 ns	204 ns	199 ns	800 ns	Pass
Delay Skew = 5 ns (Pairs 4,5 and 7,8)      45 ns						

**NEXT:PASS**

<u>NE/FE</u>	<u>PAIRS</u>	<u>Result</u>	<u>Worst Case</u>	<u>Limit</u>	<u>Margin</u>
NE	1,2:3,6	Pass	32.6 dB @ 100 MHz	>29.3 dB	3.3 dB
NE	1,2:4,5	Pass	32.6 dB @ 100 MHz	>29.3 dB	3.3 dB
NE	1,2:7,8	Pass	32.6 dB @ 100 MHz	>29.3 dB	3.3 dB
NE	3,6:4,5	Pass	32.6 dB @ 100 MHz	>29.3 dB	3.3 dB
NE	3,6:7,8	Pass	32.6 dB @ 100 MHz	>29.3 dB	3.3 dB
NE	4,5:7,8	Pass	32.6 dB @ 100 MHz	>29.3 dB	3.3 dB
FE	1,2:3,6	Pass	32.6 dB @ 100 MHz	>29.3 dB	3.3 dB
FE	1,2:4,5	Pass	32.6 dB @ 100 MHz	>29.3 dB	3.3 dB
FE	1,2:7,8	Pass	32.6 dB @ 100 MHz	>29.3 dB	3.3 dB
FE	3,6:4,5	Pass	32.6 dB @ 100 MHz	>29.3 dB	3.3 dB
FE	3,6:7,8	Pass	32.6 dB @ 100 MHz	>29.3 dB	3.3 dB
FE	4,5:7,8	Pass	32.6 dB @ 100 MHz	>29.3 dB	3.3 dB

ACR: 17.1 dB

Headroom: 7.1 dB

**Power Sum NEXT**

<u>NE/FE</u>	<u>PAIRS</u>	<u>Worst Case</u>	<u>Limit</u>	<u>Margin</u>
NE	1,2	32.6 dB @ 100 MHz	>29.3 dB	3.3 dB
NE	3,6	32.6 dB @ 100 MHz	>29.3 dB	3.3 dB
NE	4,5	32.6 dB @ 100 MHz	>29.3 dB	3.3 dB
NE	7,8	32.6 dB @ 100 MHz	>29.3 dB	3.3 dB
FE	1,2	32.6 dB @ 100 MHz	>29.3 dB	3.3 dB
FE	3,6	32.6 dB @ 100 MHz	>29.3 dB	3.3 dB
FE	4,5	32.6 dB @ 100 MHz	>29.3 dB	3.3 dB
FE	7,8	32.6 dB @ 100 MHz	>29.3 dB	3.3 dB

Power Sum ACR: 12.7 dB

Power Sum Headroom: 2.1 dB

# Appendix A

## Safety Precautions

---

### Contents

- Read all precautions before handling battery packs

### Handle Battery Packs With Care

**CAUTION** - All Nickel-Metal Hydride (NiMH) battery packs, regardless of their indicated charge state, are capable of producing electrical currents sufficient to cause personal injury and/or property damage.

Wavetek Wandel Goltermann has tried to provide the maximum protection possible by installing an automatic reset fuse in every battery pack to help stop high current discharges as quickly as possible. However, this fuse may not completely protect against a momentary arc, which can result if the battery pack's electrical contacts are shorted. The following are battery pack handling precautions that must be closely followed to avoid risk of injury.

**DO NOT** dispose of NiMH battery packs in a fire or with regular trash. NiMH batteries may explode if exposed to open flame, create hazardous waste and contaminate ground water sources if disposed of in land fills.

The following are battery pack handling precautions:

- When a battery pack is not installed in the handset or the charger, it should be kept in a clean dry non-conductive package.
- Keep conductive materials away from the battery contacts at all times.
- Keep the contact sides of the battery packs away from each other at all times.

## Appendix A Safety Precautions

---

- Batteries are normally charged while in the handsets or when using the optional Dual Bay Battery Charger. Charging with other chargers or in any other manner may cause the battery packs to explode.
- Always install, remove, store and charge the battery packs in a non-explosive atmosphere.
- Use and store battery packs in locations that do not exceed 122 degrees Fahrenheit (50 degrees Celsius).
- Do not allow children or persons unfamiliar with the precautionary instructions in this manual to handle or recharge the battery packs.
- Leave the sealed battery pack case intact. There are no user-serviceable parts inside the case and the batteries in the case are not replaceable.

### Statement of Liability

Wavetek Wandel Goltermann does NOT assume any liability for death, injury or damage to equipment or property resulting from the use of this charger in a manner inconsistent with the use for which it was intended. WWG will not be liable for consequences that may result from tampering with the battery packs or charger or consequences resulting from their use thereafter.

### Thanks For Helping To Protect The Environment

If you have any questions concerning these precautions, the operating instructions, or any other concerns about the safe operation of the LT 8000 Series battery packs, please contact a WWG representative at one of the offices listed in *Appendix B* of this manual, Customer Service and Warranty.

## Important User Information

Please read this information before proceeding with any cable testing/certification using the LT 8000 Series tester.

All the cable parameter default settings preprogrammed in the LT 8000 Series testers are based on generic standards, proposed industry recommendations for cables and network links, the latest technical information available from International LAN cabling standards committees, the LAN industry and WWG's own experience and testing. However, the default settings in the tester may not yield the desired certification / test results in every given instance because each network is a custom installation designed to suit the requirements of the users. It is therefore imperative that specific network parameter limits be obtained from the network designer(s) and employed during certification and testing.

Refer to *Chapter 3* for information and instructions on how to select the correct cable type, change testing methods, and customize the cable's parameters for certification and testing. *Chapter 5, Table 5-1* provides a complete list of cable topologies supported.



# Appendix B

## Customer Support

---

### Customer Service

#### Technical Assistance

For technical assistance or service questions in the U.S.A. and Canada, call Wavetek Wandel Goltermann at 1-800-854-2708 or 858-279-2200.

#### Service in the USA

Your LT 8000 Series tester may require annual calibration to meet accuracy specifications. Before returning a unit for calibration or service, call Wavetek Wandel Goltermann Technical Support at 1-800-854-2708 or 619-279-2200.

If cleaning is required, use a soft cloth and mild cleaner suitable for plastic. Do not immerse in water.

#### When returning a unit for service or calibration:

1. Customer name, company, address, telephone number, proof of purchase (for warranty repairs), and a description of the service is required. Use the guidelines below to repack the unit with commercially-available materials, if the original packing materials are not available.
2. Pack in soft carrying case, hard-sided carrying case or wrap the instrument in heavy paper or plastic.
3. Use a strong shipping container. A double-walled carton of 250-pound test material is recommended.

## Appendix B Customer Support

---

4. Use a layer of shock-absorbing material 70 to 100 mm (3 to 4 inches) thick around all sides of the instrument to provide firm cushioning and to prevent the unit from moving inside the container.
5. Seal the shipping container securely.
6. Ship prepaid to:

Wavetek Wandel Goltermann  
9145 Balboa Avenue  
San Diego, CA 92123  
ATTN: Instrument Repair/Service

Return shipping to the customer within the domestic U.S.A. will be paid by Wavetek Wandel Goltermann.

## **Service Outside the USA**

For technical assistance or service questions outside the U.S.A. and Canada, call your local distributor.

Wavetek Wandel Goltermann recommends annual calibration of the LT 8000 Series tester to ensure that it continually meets its accuracy specifications. Before returning a unit for calibration or service outside the U.S.A., contact your local distributor or one of the WWG offices listed below. If your local distributor does not have a service facility, they will provide assistance in returning the tester to an authorized WWG service facility.

If cleaning is required, use a soft cloth and mild cleaner suitable for plastic. Do not immerse in water.

### **Americas**

Wavetek Wandel Goltermann  
9145 Balboa Avenue  
San Diego, CA 92123  
Tel: 800-854-2708  
Fax: 858-627-0130

### **Europe (Western) and Africa**

Wavetek GmbH  
Gutenbergstrasse 2-4  
85737 Ismaning Germany  
Tel: 49-89-996-410  
Fax: 49-89-996-411-60

**United Kingdom**  
**Netherlands, Belgium, Luxembourg, Sweden, Norway, Finland,**  
**Denmark, Iceland**

Wavetek Ltd.  
Hurricane Way, Norwich  
Norfolk NR6 6JB U.K.  
Tel: 44-1603-404824  
Fax: 44-1603-483670

**Austria, Europe (Eastern)**

Wavetek Gesellschaft m.b.H.  
Pharos Haus  
Nordbahnstrasse 36/TOP 1.4  
A – 1020 Vienna, Austria  
Tel: 43-1-214-51-10  
Fax: 43-1-214-51-09

**China**

Wavetek Corporation  
Unit 1608, Corporate Square  
No. 35 Jinrong Street  
Xicheng District, Beijing, China  
Tel: 86-10-8809 1288  
Fax: 86-10-8809 1298

**Asia**

Wavetek Hong Kong Ltd.  
Unit 1901-2, 19/F  
Jubilee Centre  
No. 18, Fenwick Street  
Wanchai, Hong Kong

Tel: 852-252 86283  
Fax: 852-252 95593

## **World Wide Web**

Download the latest version upgrades, cable test application notes, Q&A forum, and product announcements.

Wavetek Wandel Goltermann provides a World Wide Web (WWW) site for LAN cable test products that allows you to use a PC and modem to obtain the latest information on cable test application notes or firmware version upgrades. A question and answer forum allows you to share information with other users and query WWG product managers.

You can download the latest firmware upgrades for your LT 8000 Series tester using a PC computer.

### **To download upgrade files:**

Upgrade files are available on the World Wide Web at:

**<http://www.wwgsolutions.com> and <ftp://www.wwgsolutions.com>**

*Note: When searching <ftp://www.wwgsolutions.com>, look in the public directory (Pub) for the list of available upgrades and download those you desire.  
Be sure to read all the "xx README.1ST" files before performing any upgrades.*



# Appendix C

## Measurement Methods and Limits

---

### Specifications Details

A number of parameters, comparisons, and definitions for category 3, 5, 5e & 6; and ISO Class C, D & E cables are presented in this section.

Topics include tables and graphs that define and compare:

- Level I, II, and III accuracy levels
- Which tests are required
- Worst allowable pair-to-pair measured performance levels
- Basic and channel link test limits

**Appendix C**  
**Measurement Methods and Limits**

**Attenuation**

Measures the overall signal strength loss in the cable. Attenuation (worst pair-to-pair)  
 @ 20 degrees Celsius.

**ANSI/EAI/TIA**

Frequency (MHz/dB)	Category 3		Category 5		Category 5e		Proposed CAT 6 (Draft5)	
	ANSI/TIA/EIA568/TSB67		ANSI/TIA/EIA568/TSB67/95		ANSI/TIA/EIA568/TSB67/95		ANSI/TIA/EIA568	
	Link	Channel	Link	Channel	Link	Channel	Link	Channel
1.00	3.20	4.20	2.10	2.50	2.10	2.20	2.00	2.10
4.00	6.10	7.30	4.00	4.50	4.00	4.50	3.70	4.00
8.00	8.80	10.20	5.70	6.30	5.70	6.30	5.20	5.60
10.00	10.00	11.50	6.30	7.00	6.30	7.10	5.80	6.30
16.00	13.20	14.90	8.20	9.20	8.20	9.10	7.30	8.00
20.00			9.20	10.30	9.20	10.20	8.20	9.00
25.00			10.30	11.40	10.30	11.40	9.20	10.10
31.25			11.50	12.80	11.50	12.90	10.40	11.30
62.50			16.70	18.50	16.70	18.60	14.90	16.30
100.00			21.60	24.00	21.60	24.00	19.20	20.90
155.52							24.40	26.60
250.00							31.80	34.60

**ISO/AS/NZS**

Frequency (MHz/dB)	ISO Class-C		ISO Class-D 11801 AS/NZS 3080		Proposed ISO Class-D		Proposed ISO Class-E	
	Link	Channel	Link	Channel	Link	Channel	Link	Channel
	1.00	3.10	4.20	2.10	2.50	1.90	2.20	1.90
4.00	5.80	7.30	4.10	4.50	3.80	4.40	3.50	4.20
8.00	8.90	10.50	5.50	6.50	5.80	6.70	5.00	5.80
10.00	9.60	11.50	6.10	7.00	6.10	7.00	5.60	6.50
16.00	12.60	14.90	7.80	8.90	7.70	8.90	7.10	8.30
20.00			8.70	10.30	8.70	10.00	7.90	9.30
25.00			10.00	11.50	10.30	11.80	8.90	10.40
31.25			11.00	12.80	11.00	12.60	10.00	11.70
62.50			16.00	18.50	15.90	18.30	14.40	16.90
100.00			20.60	24.00	20.60	23.60	18.50	21.70
155.52							23.60	27.60
250.00							30.70	36.00

**NEXT**

Measures crosstalk from a transmitting pair to an adjacent pair in the same cable sheath.  
NEXT (worst pair to pair).

**ANSI/EIA/TIA**

Frequency (MHz/dB)	Category 3		Category 5		Category 5e		Proposed CAT 6 (Draft5)	
	ANSI/TIA/EIA568/TSB67		ANSI/TIA/EIA568/TSB67/95		ANSI/TIA/EIA568/TSB67/95		ANSI/TIA/EIA568	
	Link	Channel	Link	Channel	Link	Channel	Link	Channel
1.00	40.10	39.10	61.30	60.30	60.00	60.00	73.40	72.70
4.00	30.70	29.30	51.80	50.60	54.80	53.60	64.10	63.10
8.00	25.90	24.30	47.10	45.60	50.00	48.60	59.40	58.20
10.00	24.30	22.70	45.50	44.00	48.50	47.00	57.80	56.60
16.00	21.00	19.30	42.30	40.60	45.20	43.60	54.60	53.20
20.00			40.70	39.00	43.70	42.00	53.10	51.60
25.00			39.10	37.40	42.10	40.40	51.50	50.00
31.25			37.60	35.70	40.60	38.70	50.00	48.40
62.50			32.70	30.60	35.70	33.60	45.10	43.40
100.00			29.30	27.10	32.30	30.10	41.80	39.90
155.52							38.70	36.70
250.00							35.30	33.10

**ISO/AS/NZS**

Frequency (MHz/dB)	ISO Class-C		ISO Class-D 11801 AS/NZS 3080		Proposed ISO Class-D		Proposed ISO Class-E	
	Link	Channel	Link	Channel	Link	Channel	Link	Channel
1.00	40.10	39.10	54.00	54.00	61.20	60.30	72.70	72.70
4.00	30.70	29.30	45.00	45.00	51.80	50.60	63.00	63.10
8.00	25.90	24.30	41.00	41.00	47.10	45.60	58.20	58.20
10.00	24.30	22.70	39.00	39.00	45.50	44.00	56.60	56.60
16.00	21.00	19.30	36.00	36.00	42.30	40.60	53.20	53.20
20.00			35.00	35.00	40.70	39.00	51.60	51.60
25.00			33.60	33.60	39.10	37.40	50.00	50.00
31.25			32.00	32.00	37.60	35.70	48.40	48.40
62.50			27.00	27.00	32.70	30.60	43.40	43.40
100.00			24.00	24.00	29.30	27.10	39.90	39.90
155.52							36.70	36.70
250.00							33.10	33.10

**Appendix C**  
**Measurement Methods and Limits**

---

**Power Sum NEXT**

Measures the crosstalk effects of three transmitting pairs on the fourth pair in the same sheath. Power Sum NEXT.

**ANSI/TIA/EIA**

Frequency (MHz/dB)	Category 3 ANSI/TIA/EIA568/TSB67		Category 5 ANSI/TIA/EIA568/TSB67/95		Category 5e ANSI/TIA/EIA568/TSB67/95		Proposed CAT 6 (Draft5) ANSI/TIA/EIA568	
	Link	Channel	Link	Channel	Link	Channel	Link	Channel
1.00					57.00	57.00	71.20	70.30
2.00								
3.00								
4.00					52.00	50.90	61.80	60.50
8.00					47.10	45.70	57.00	55.60
10.00					45.60	44.10	55.50	54.00
16.00					42.20	40.60	52.20	50.60
20.00					40.70	39.00	50.70	49.00
25.00					39.10	37.30	49.10	47.30
31.25					37.50	35.70	47.50	45.70
62.50					32.60	30.60	42.70	40.60
100.00					29.30	27.10	39.30	37.10
125.00							37.70	35.40
155.52							36.10	33.80
175.00							35.30	32.90
200.00							34.30	31.90
250.00							32.70	30.20

**ISO**

Frequency (MHz/dB)	ISO Class-C		ISO Class-D 11801 AS/NZS 3080		Proposed ISO Class-D		Proposed ISO Class-E	
	Link	Channel	Link	Channel	Link	Channel	Link	Channel
1.00					58.20	57.30	70.30	70.30
2.00								
3.00								
4.00					48.20	47.60	60.50	60.50
8.00					44.00	42.50	55.60	55.60
10.00					42.50	41.00	54.00	54.00
16.00					39.30	37.60	50.60	50.60
20.00					37.70	36.00	49.00	49.00
25.00					36.00	34.50	47.30	47.30
31.25					34.60	32.70	45.70	45.70
62.50					29.70	27.60	40.60	40.60
100.00					26.30	24.10	37.10	37.10
125.00							35.40	35.40
155.52							33.80	33.80
175.00							32.90	32.90
200.00							31.90	31.90
250.00							30.20	30.20

## Return Loss

Return Loss is the ratio of reflected to transmitted signal. Return Loss (worst pair to pair).

### ANSI/TIA/EIA

Frequency (MHz/dB)	Category 3		Category 5		Category 5e		Proposed CAT 6 (Draft5)	
	ANSI/TIA/EIA568/TSB67		ANSI/TIA/EIA568/TSB67/95		ANSI/TIA/EIA568/TSB67/95		ANSI/TIA/EIA568	
	Link	Channel	Link	Channel	Link	Channel	Link	Channel
1.00	15.00	15.00	15.00	15.00	17.00	17.00	19.00	19.00
4.00	15.00	15.00	15.00	15.00	17.00	17.00	19.00	19.00
8.00	15.00	15.00	15.00	15.00	17.00	17.00	19.00	19.00
10.00	15.00	15.00	15.00	15.00	17.00	17.00	19.00	19.00
16.00	15.00	15.00	15.00	15.00	17.00	17.00	19.00	19.00
20.00			15.00	15.00	17.00	17.00	19.00	19.00
25.00			14.30	14.00	16.32	16.03	18.30	18.00
31.25			13.60	13.10	15.64	15.06	17.60	17.10
62.50			11.50	10.10	13.54	12.05	15.50	14.10
100.00			10.10	8.00	12.11	10.01	14.10	12.00
155.52							12.80	10.10
250.00							11.30	8.00

### ISO/AS/NZS

Frequency (MHz/dB)	ISO Class-C		ISO Class-D 11801 AS/NZS 3080		Proposed ISO Class-D		Proposed ISO Class-E	
	Link	Channel	Link	Channel	Link	Channel	Link	Channel
	1.00	15.00	15.00	17.00	17.00	15.00	15.00	19.00
4.00	15.00	15.00	17.00	17.00	15.00	15.00	19.00	19.00
8.00	15.00	15.00	17.00	17.00	15.00	15.00	19.00	19.00
10.00	15.00	15.00	17.00	17.00	15.00	15.00	19.00	19.00
16.00	15.00	15.00	17.00	17.00	15.00	15.00	19.00	19.00
20.00			17.00	17.00	15.00	15.00	19.00	19.00
25.00			16.30	16.00	14.30	14.00	18.30	18.00
31.25			15.60	15.10	13.60	13.10	17.60	17.10
62.50			13.50	12.10	11.50	10.10	15.50	14.10
100.00			12.10	10.00	10.10	8.00	14.10	12.00
155.52							12.80	10.10
250.00							11.30	8.00

*Note: Return Loss applies only to TSB95.*

**Appendix C**  
**Measurement Methods and Limits**

**ACR**

Attenuation-to-Crosstalk Ratio is the difference between results of Attenuation and NEXT. ACR (worst pair to pair).

**ANSI/TIA/EIA**

Frequency (MHz/dB)	Category 3		Category 5		Category 5e		Proposed CAT 6 (Draft5)	
	ANSI/TIA/EIA568/TSB67		ANSI/TIA/EIA568/TSB67/95		ANSI/TIA/EIA568/TSB67/95		ANSI/TIA/EIA568	
	Link	Channel	Link	Channel	Link	Channel	Link	Channel
1.00	36.90	34.90	59.20	57.80	57.90	57.80	71.50	70.50
4.00	24.60	22.00	47.80	46.10	50.80	49.10	60.40	59.10
8.00	17.10	14.10	41.40	39.30	44.30	42.30	54.20	52.50
10.00	14.30	11.20	39.20	37.00	42.20	39.90	52.10	50.30
16.00	7.80	4.40	34.10	31.40	37.00	34.50	47.30	45.20
20.00			31.50	28.70	34.50	31.80	44.80	42.70
25.00			28.80	26.00	31.80	29.00	42.30	40.00
31.25			26.10	22.90	29.10	25.80	39.60	37.10
62.50			16.00	12.10	19.00	15.00	30.20	27.10
100.00			7.70	3.10	10.70	6.10	22.60	19.00
155.52							14.30	10.00
250.00							3.50	-

**ISO/AS/NZS**

Frequency (MHz/dB)	ISO Class-C		ISO Class-D 11801 AS/NZS 3080		Proposed ISO Class-D		Proposed ISO Class-E	
	Link	Channel	Link	Channel	Link	Channel	Link	Channel
	1.00	37.00	34.90	51.50	51.30	59.30	58.10	70.80
4.00	24.90	22.00	40.20	39.80	48.00	46.20	59.50	58.90
8.00	17.00	13.80	34.10	33.90	41.30	38.90	53.20	52.30
10.00	14.70	11.20	31.50	30.90	39.40	37.00	51.00	50.00
16.00	8.40	4.40	26.60	25.90	34.60	31.70	46.10	44.90
20.00			24.50	23.70	32.00	29.00	43.70	42.30
25.00			21.90	21.10	28.80	25.60	41.10	39.60
31.25			18.90	17.90	26.60	23.10	38.40	36.70
62.50			8.60	7.20	16.80	12.30	29.00	26.50
100.00			4.00	4.00	8.70	3.50	21.40	18.20
155.52							13.10	9.00
250.00							2.40	-

## Power Sum ACR (ANSI/TIA/EIA)

### ANSI/TIA/EIA

Frequency (MHz/dB)	Category 3 ANSI/TIA/EIA568/TSB67		Category 5 ANSI/TIA/EIA568/TSB67/95		Category 5e ANSI/TIA/EIA568/TSB67/95		Proposed CAT 6 (Draft5) ANSI/TIA/EIA568	
	Link	Channel	Link	Channel	Link	Channel	Link	Channel
	1.00					54.90	54.80	71.20
2.00								
3.00								
4.00					48.00	46.40	61.80	60.50
8.00					41.40	39.40	57.00	55.60
10.00					39.30	37.00	55.50	54.00
16.00					34.00	31.50	52.20	50.60
20.00					31.50	28.80	50.70	49.00
25.00					28.80	25.90	49.10	47.30
31.25					26.00	22.80	47.50	45.70
62.50					15.90	12.00	42.70	40.60
100.00					7.70	3.10	39.30	37.10
125.00							37.70	35.40
155.52							36.10	33.80
175.00							35.30	32.90
200.00							34.30	31.90
250.00							32.70	30.20

### ISO

Frequency (MHz/dB)	ISO Class-C		ISO Class-D 11801 AS/NZS 3080		Proposed ISO Class-D		Proposed ISO Class-E	
	Link	Channel	Link	Channel	Link	Channel	Link	Channel
1.00					56.10	54.80	68.40	68.10
2.00								
3.00								
4.00					44.70	43.10	57.00	56.40
8.00					38.50	36.00	50.60	49.70
10.00					36.40	34.00	48.40	47.50
16.00					31.50	28.70	43.50	42.30
20.00					29.00	25.70	41.00	39.70
25.00					26.00	23.00	38.40	36.90
31.25					23.60	19.90	35.70	34.00
62.50					13.70	9.10	26.20	23.70
100.00					5.70	0.10	18.60	15.40
125.00							14.50	10.90
155.52							10.20	6.10
175.00							7.70	3.40
200.00							4.80	0.10
250.00							-	-

**Appendix C**  
**Measurement Methods and Limits**

**ELFEXT**

The same measurement as NEXT except the crosstalk is measured from the RH and sent to DH. ELFEXT (worst pair to pair).

**ANSI/TIA/EIA**

Frequency (MHz/dB)	Category 3		Category 5		Category 5e		Proposed CAT 6 (Draft5)	
	ANSI/TIA/EIA568/TSB67		ANSI/TIA/EIA568/TSB67/95		ANSI/TIA/EIA568/TSB67/95		ANSI/TIA/EIA568	
	Link	Channel	Link	Channel	Link	Channel	Link	Channel
1.00			59.60	57.00	58.00	57.40	65.20	63.20
4.00			47.50	45.00	48.00	45.30	53.20	51.20
8.00			41.50	38.90	41.90	39.30	47.10	45.20
10.00			39.60	37.00	40.00	37.40	45.20	43.20
16.00			35.50	32.90	35.90	33.30	41.10	39.10
20.00			33.60	31.00	34.00	31.40	39.20	37.20
25.00			31.60	29.00	32.00	29.40	37.20	35.30
31.25			29.70	27.10	30.10	27.50	35.30	33.30
62.50			23.70	21.10	24.10	21.50	29.30	27.30
100.00			19.60	17.00	20.00	17.40	25.20	23.20
155.52							21.40	19.40
250.00							17.20	15.30

**ISO/AS/NZS**

Frequency (MHz/dB)	ISO Class-C		ISO Class-D 11801 AS/NZS 3080		Proposed ISO Class-D		Proposed ISO Class-E	
	Link	Channel	Link	Channel	Link	Channel	Link	Channel
	1.00			59.60	57.00			64.20
4.00			47.60	45.00			52.10	51.20
8.00			42.00	39.00			46.10	45.20
10.00			39.60	37.00			44.20	43.20
16.00			35.50	32.90			40.10	39.10
20.00			33.60	31.00			38.10	37.20
25.00			31.00	29.00			36.20	35.30
31.25			29.70	27.10			34.30	33.30
62.50			23.70	21.10			28.20	27.30
100.00			19.60	17.00			24.20	23.20
155.52							20.30	19.40
250.00							16.20	15.30

*Note: ELFEXT applies only to TSB95.*

## Power Sum ELFEXT (ANSI/TIA/EIA)

### ANSI/TIA/EIA

Frequency (MHz/dB)	Category 3		Category 5		Category 5e		Proposed CAT 6 (Draft5)	
	ANSI/TIA/EIA568/TSB67		ANSI/TIA/EIA568/TSB67/95		ANSI/TIA/EIA568/TSB67/95		ANSI/TIA/EIA568	
	Link	Channel	Link	Channel	Link	Channel	Link	Channel
1.00					55.00	54.40	62.20	60.20
2.00								
3.00								
4.00					45.00	42.40	50.20	48.20
8.00					38.90	36.30	44.10	42.20
10.00					37.00	34.40	42.20	40.20
16.00					32.90	30.30	38.10	36.10
20.00					31.00	28.40	36.20	34.20
25.00					29.00	26.40	34.20	32.30
31.25					27.10	24.50	32.30	30.30
62.50					21.10	18.50	26.30	24.30
100.00					17.00	14.40	22.20	20.20
125.00							20.30	18.30
155.52							18.40	16.40
175.00							17.30	15.40
200.00							16.20	14.20
250.00							14.20	12.30

### ISO

Frequency (MHz/dB)	ISO Class-C		ISO Class-D 11801 AS/NZS 3080		Proposed ISO Class-D		Proposed ISO Class-E	
	Link	Channel	Link	Channel	Link	Channel	Link	Channel
1.00					57.00	54.40	61.20	60.20
2.00								
3.00								
4.00					45.00	42.40	49.10	48.20
8.00					39.00	36.00	43.10	42.20
10.00					37.00	34.40	41.20	40.20
16.00					32.90	30.30	37.10	36.10
20.00					31.00	28.40	35.10	34.20
25.00					29.00	26.50	33.20	32.30
31.25					27.10	24.50	31.30	30.30
62.50					21.10	18.50	25.20	24.30
100.00					17.00	14.40	21.20	20.20
125.00							19.20	18.30
155.52							17.30	16.40
175.00							16.30	15.40
200.00							15.10	14.50
250.00							13.20	12.30

## Tester Performance Levels

There are two types of performance levels you need to considered when preparing to perform cable testing:

- The performance category of the cable system.
- The accuracy of the field tester.

## Twisted Pair Cable Categories

<b>Categories</b>	<b>Description</b>
CAT 1 and 2	UTP, Not recommended for LAN use.
CAT 3	Four Pairs with three twists per foot. Rated for signals up to 16 MHz.
CAT 4	Four Pairs per foot. Rated for signals up to 20 MHz.
CAT 5	Four Pairs with eight twists per foot. Rated for signals up to 100 MHz.
CAT 5E	Same characteristics as CAT 5. Higher quality cable (low crosstalk). Rated for signals up to 200 MHz.
CAT 6	Four Pairs cable with each pair wrapped in foil insulation. Rated for signals greater than 250 MHz.

## Field Tester Accuracy

It is difficult to determine which type of tester may be required for certification. Generally, Level I testers are used by LAN managers for casual troubleshooting. Level II and Level III testers are used by cable installation contractors.

### What does “accuracy” mean?

Accuracy is the difference between the measured value reported by the LT 8000 Series tester and the actual value. Accuracy is a function of the characteristics of the field tester and link transmission characteristics.

### Requirements for Level I, II, and III Accuracy

Accuracy requirements are specified in the TIA/EIA 568-A, TSB67, and ISO Class-E specifications. A CAT6 tester like the LT 8600 is required to meet Level III requirements from 1 to 250 MHz.

**Appendix C**  
**Measurement Methods and Limits**

---

**Accuracy Levels**

The following tables define the Level I, II, and III accuracy levels defined by the TIA/EIA 568-A, TSB67, and ISO Class-E specifications.

	Level I 1 - 100 MHz	Level II 1 - 100 MHz
Random Noise Floor	50 -15 log (f/200)dB	65 -15 log (f/200)dB
Residual NEXT	40 -15 log (f/200)dB	55 -15 log (f/200)dB
Output Signal Balance	27 -15 log (f/200)dB	37 -15 log (f/200)dB
Common Mode Rejection	27 -15 log (f/200)dB	37 -15 log (f/200)dB
Dynamic Accuracy	± 1.0 dB	± 0.75 dB
Length Accuracy	± 1 meter ± 4%	± 1 meter ± 4%
Return Loss	15 dB	15 dB
Directivity	--	--
Delay	--	--

	Level III - Draft 3 1 - 250 MHz	Level III - New Proposal 1 - 250 MHz
Random Noise Floor	70 -15 log (f/200)dB	75 -15 log (f/100)dB
Residual NEXT	60 -15 log (f/200)dB	65 -20 log (f/100)dB
Output Signal Balance	35 -15 log (f/200)dB	40 -20 log (f/100)dB
Common Mode Rejection	35 -15 log (f/200)dB	40 -20 log (f/100)dB
Dynamic Accuracy	± 0.5 dB	± 0.75 dB (±1.0 dB ELFEXT)
Length Accuracy	± 1 meter ± 4%	± 1 meter ± 4%
Return Loss	15 -15 log (f/200)dB	25 -15 log (f/100)dB
Directivity	25 -15 log (f/200)dB	27 -7 log (f/100)dB
Delay	5 ns + 4%	5 ns + 4%

## Basic and Channel Link Test Limits

The following tables define the basic and channel link test limits defined by the TIA/EIA 568-A, TSB67, ISO Class-C, D, and E specifications

### ANSI/TIA/EIA

TEST Limits	TSB67 Category 3		TSB67/95 Category 5		Proposed TSB67 Category 5e		Proposed TSB67 Category 6	
	Link	Channel	Link	Channel	Link	Channel	Link	Channel
Length (m)	94	100	94	100	94	100	94	100
Loop Resistance (DC Ohm)	20	20	20	20	20	20	40	40
Capacitance/m	66pF	66pF	66pF	66pF	66pF	66pF	66pF	66pF
Delay (10MHz)	510	548	510	548	510	548	506	557
Skew/ns	43	50	43	50	43	50	43	50
Impedance (Ohm)	85-115	85-115	85-115	85-115	85-115	85-115	85-115	85-115

### ISO/AS/NZS

TEST Limits	ISO Class-C		ISO Class-D 11801 AS/NZS 3080		Proposed ISO Class-D		Proposed ISO Class-E	
	Link	Channel	Link	Channel	Link	Channel	Link	Channel
Length (m)	90	100	90	100	90	100	90	100
Loop Resistance (DC Ohm)	40	40	40	40	40	40	40	40
Capacitance/m	56pF	56pF	56pF	56pF	56pF	56pF	66pF	66pF
Delay (10MHz)	497	555	497	555	497	555	497	555
Skew/ns	43	50	43	50	43	50	43	50
Impedance (Ohm)	85-115	85-115	85-115	85-115	85-115	85-115	85-115	85-115



## Appendix D Specifications

---

### Standard and Optional Cables, Adapters, and Accessories

Model Number	Description
LT8BATTPACK	Battery Pack Cartridge for Handsets; Extra/Spare/Replacement
LT8TALKSET	Headset, Set of 2; Includes earphone, microphone, vinyl case and user's guide
LT8BTCHG120(*c)	Dual Bay, Quick Charge Battery Recharger for LT 8000 Series; 120V Powered
LT8BTCHG240(*c)	Dual Bay, Quick Charge Battery Recharger for LT 8000 Series; 240V Powered
LT8110	110-Block Link Adapters (568A & 568B); Set of 2
LT8IBMA	Token-Ring Link Adapters (Type 1,1A,2,6,6A IBM); Set of 2
LT8COAXA	Coaxial Link Adapter Kit (Incl: 10BASE-2 ThinNet; 10BASE-5 ThickNet, and Twinax)
LT8CHANNEL	8-Pin Modular Jack Link Adapters; Set of 2
LT8DCC	Deluxe Hard-Shell Carrying Case; holds tester set, rechargers, link adapters and accessories
LT8KIT120(*c)	Pro-Installer's Kit; [Includes: LT8DCC, Talkset, All Link Adapter Sets/Kits, Dual Bay Battery Recharger (240V powered) and 2 spare battery packs]
LT8KIT240(*c)	Pro-Installer's Kit; [Includes: LT8DCC, Talkset, All Link Adapter Sets/Kits, Dual Bay Battery Recharger (120V powered) and 2 spare battery packs]
LT8SRA	Extra Remote Handset (add up to 3; for use with LT 8155 and LT 8600)
LT8BASIC	RJ-45 Link Adapters, Set of 2 (Replacements or spares)

**Appendix D**  
**Model Features, Options, Accessories, and Specifications**

---

<b>Model Number</b>	<b>Description</b>
LT8AC	AC Power Adapter Module, Self-Switching Universal
LT8USCAN	AC Power Line Adapter, 120V/60Hz w USA and Canada Style Wall Plug (Replacement)
LT8EURO	AC Power Line Adapter, 220V/50Hz w European Style Wall Plug (Replacement)
LT8SCC	Standard Carrying Case; holds tester set, rechargers, link adapters and accessories
LT8BOOT	Rubber Boot Protectors for LT 8000 Series Handsets; Set of 2; (Replacements)

\*c: Specify Country Code for AC Power Cord:

CORDUSCAN = USA/Canada

CORDITALY = Italy

CORDUK = UK

CORDSWISS = Switzerland

CORDEURO = Europe

CORDAUSTNZ = Australia/New Zealand

CORDDENMARK = Denmark

CORDJAPAN = Japan

## **Environmental and Physical Specifications**

The following environmental specifications apply to all LT 8000 Series Cable Testers.

### **Temperature Range**

Operating Temperature Range:	0 to + 50 degrees C
Specified Operating Temperature:	Field cal $\pm 10$ degrees C
Storage Temperature Range:	-20 to +70 degrees C

### **Humidity**

5-90%, noncondensing

## **Shock / Bench Handling**

The LT 8000 Series tester is capable of surviving normal bench handling procedures such as found in maintenance and repair facilities.

## **Connector Stress**

### **Strain**

All connectors and adapters will withstand a strain of > 25 lb. in any direction or orientation when attached to a DH or RH.

### **Jerk**

All connectors and adapters will withstand a jerk force of up to 1 lb. dropped from a 3 foot cord in any orientation when attached to a DH or RH.

## **Dimensions and Weight**

### **Display Handset**

Dimensions:	10"x4.25"x2.5"
Weight:	1.75 lb.

### **Remote Handset**

Dimensions:	10"x4.25"x2.5"
Weight:	1.6 lb.

## Battery and Power Management

### Display Handset

Battery Pack	8.4 Vdc, 2.45 AH, NiMH
External Source	12 Vdc, 800mA continuous

### Remote Handset

Battery Pack	8.4 Vdc, 2.45 AH, NiMH
External Source	12 Vdc, 800mA continuous

### Test Connector Input Protection

Input Impedance	2 M $\Omega$
Voltage Protection	20-200 V AC/DC

## Instrument Specifications

Instrument specifications and ranges are described in the following table.

Parameter	Range/Limits
Length	
Range	0-1100 ft.
Resolution	0.0 ft (.3m)
Accuracy	3% + 3ft. (1m)
Propagation Rate (NVP)	0.5 - 0.99c
NEXT	
Frequency Range	1 - 100MHz (8100), 1 - 155MHz (8155), 1 - 300MHz (8600)
Dynamic Range	0 - NEXT Limit + 5dB
Freq. Step Size (kHz)	150, 250 (8100, 8155) 150, 250, 500 (8600)
Resolution	0.1dB
Accuracy	Level IIE (8100, 8600) Level III (8600)
Attenuation	
Frequency Range	1 - 100MHz (8100), 1 - 155MHz (8155), 1 - 300MHz (8600)
Dynamic Range	0 - NEXT Limit + 5dB
Freq. Step Size (kHz)	150, 250 (8100, 8155) 150, 250, 500 (8600)
Atten. Resolution	0.1dB
Atten. Accuracy	Level IIE (8100, 8600) Level III (8600)

**Appendix D**  
**Model Features, Options, Accessories, and Specifications**

---

<b>Parameter</b>	<b>Range/Limits</b>
FEXT	
Frequency Range	1 - 100MHz (8100), 1 - 155MHz (8155), 1 - 300MHz (8600)
Dynamic Range	0 - NEXT Limit + 5dB
Freq. Step Size (kHz)	150, 250 (8100, 8155) 150, 250, 500 (8600)
Resolution	0.1dB
Accuracy	Level IIE (8100, 8600) Level III (8600)
ELFEXT	
Frequency Range	1 - 100MHz (8100), 1 - 155MHz (8155), 1 - 300MHz (8600)
Dynamic Range	0 - NEXT Limit + 5dB
Freq. Step Size (kHz)	150, 250 (8100, 8155) 150, 250, 500 (8600)
Resolution	0.1dB
Accuracy	Level IIE (8100, 8600) Level III (8600)
DC Loop Resistance	
Range	0 - 200 Ohms
Resolution	0.1 Ohms
Accuracy	+/- (1% + 2 Ω)

**Appendix D**

**Model Features, Options, Accessories, and Specifications**

---

Parameter	Range/Limits
Return Loss	
Frequency Range	1 - 155MHz (8100, 8155), 1 - 300MHz (8600)
Measurement Range	0 - 30 dB
Freq. Step Size (kHz)	150, 250 (8100, 8155) 150, 250, 500 (8600)
Resolution	0.1 dB
Accuracy	Level IIE (8100, 8600) Level III (8600)
Delay and Skew	
Range	0-8000ns
Resolution	1 nsec
Accuracy	±(3% + 1ns)
Impedance	
Range	35 - 180 Ω
Resolution	.2 Ω (8100) .3 Ω (8155) .1 Ω (8600)
Accuracy	+/- (3% + 1 Ω)
Capacitance (bulk)	
Range	0 – 100nf
Resolution	3 dig
Accuracy	+/- (2% + 20pF)
Capacitance (per ft.)	
Range	0 – 100nf
Resolution	0.1pF
Accuracy	+/- (2% + 1pF)

