

Customer Information Sheet

DRAWING No.: S9001-XXR

SHEET 2 OF 2

IF IN DOUBT - ASK

©

NOT TO SCALE

THIRD ANGLE PROJECTION

ALL DIMENSIONS IN mm

- NOTES:
1. SPRING FORCE WHEN DEPRESSED BY;
0.5mm = 5N MIN, 11N MAX, 1.0mm = 10N MIN, 14N MAX.
 2. CONTACT SUITABLE FOR PICK AND PLACEMENT.
 3. QUANTITY OF COMPONENTS PER REEL = 1,300.

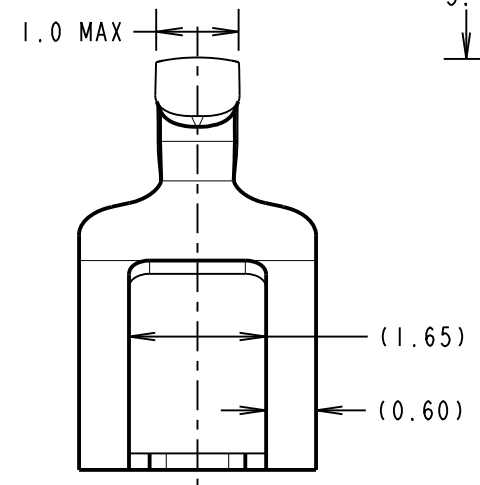
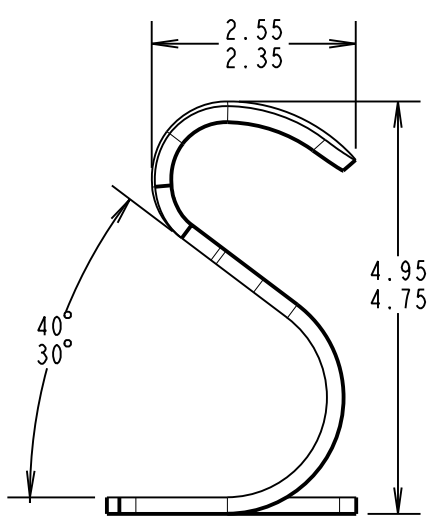
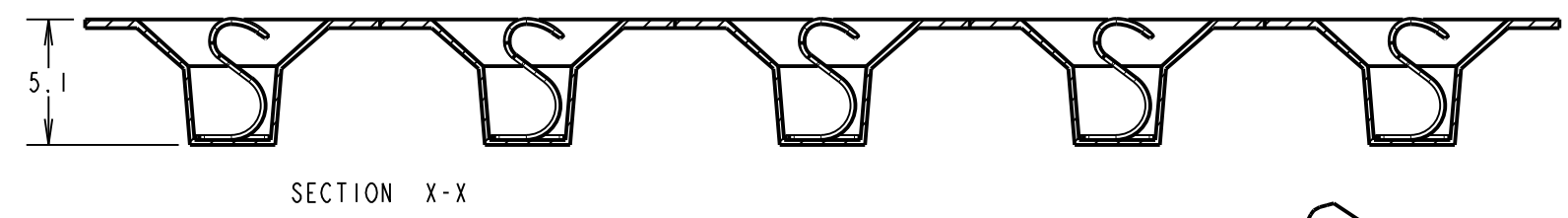
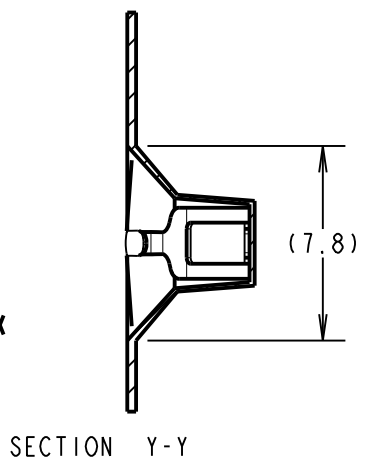
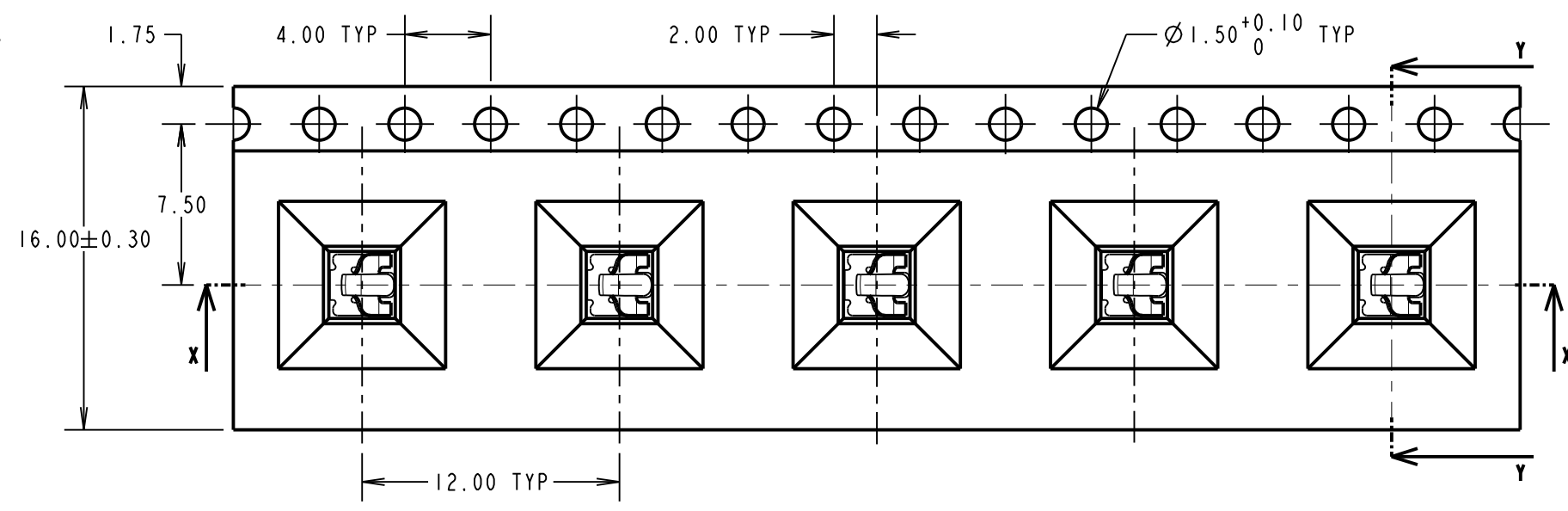
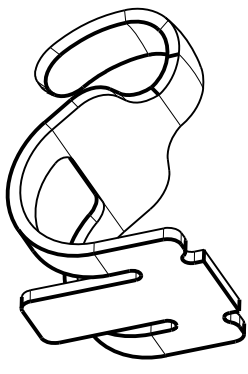
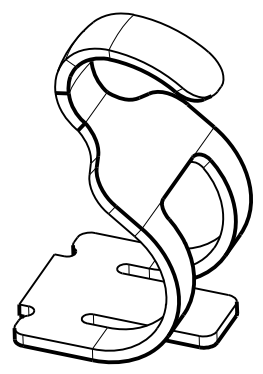

PICK AND PLACE AREA SUITABLE FOR Ø0.8 MAX NOZZLE

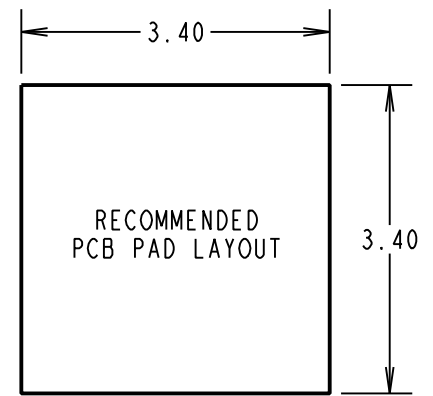
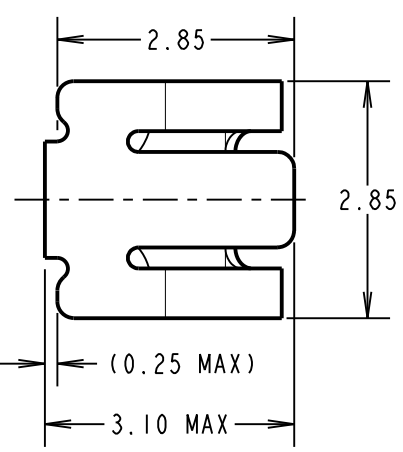
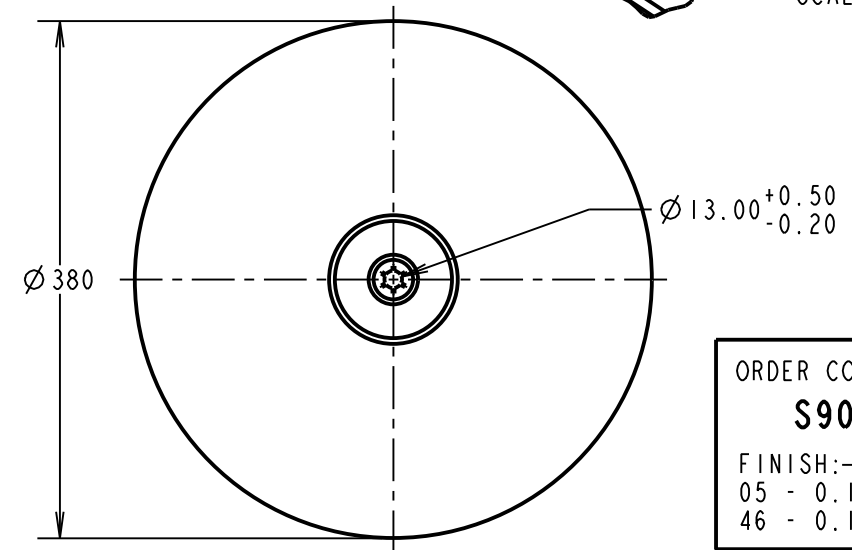
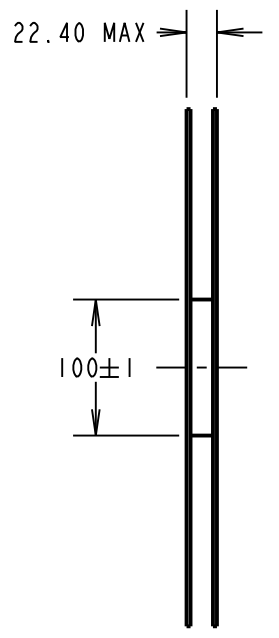
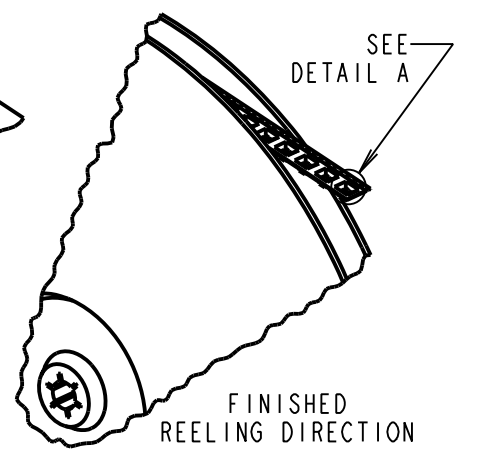
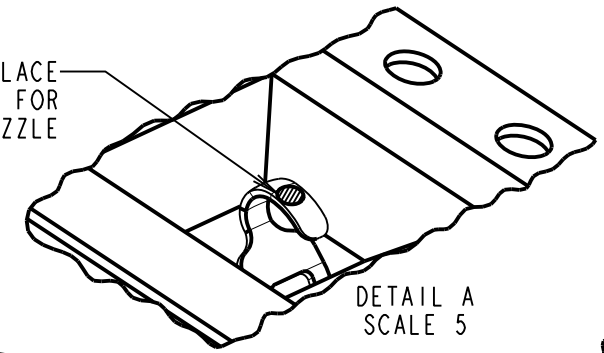

ORDER CODE:
S9001-XXR
FINISH:
05 - 0.10-0.20µ GOLD
46 - 0.10-0.20µ 100% TIN

SB	3	19.06.13	12074
NAME	ISS.	DATE	C/NOTE
APPROVED: S.BENNETT			
CHECKED: M.PLESTED			
DRAWN: S.FLOWER			
CUSTOMER REF.:			
ASSEMBLY DRG:			

SPECIFICATION:
ELECTRICAL:
CURRENT RATING = 2A

HARWIN
www.harwin.com
technical@harwin.com

THIS DRAWING AND ANY INFORMATION OR DESCRIPTIVE MATTER SET OUT HEREON ARE CONFIDENTIAL AND COPYRIGHT PROPERTY OF THE HARWIN GROUP AND MUST NOT BE DISCLOSED, LOANED, COPIED OR USED FOR MANUFACTURING, TENDERING OR FOR ANY OTHER PURPOSE WITHOUT THEIR WRITTEN PERMISSION.

TOLERANCES
X. = ±1mm
X.X = ±0.25mm
X.XX = ±0.10mm
X.XXX = ±0.01mm
ANGLES = ±5°
UNLESS STATED

MATERIAL:
STAINLESS STEEL
FINISH: SEE ORDER CODE
S/AREA: mm²

TITLE:
SMT PRESSURE CONTACT IN TAPE AND REEL
DRAWING NUMBER:
S9001-XXR
SHT 2 OF 2