



## Main

Range of product	Altistart U01 and TeSys U
Product or component type	Soft starter
Product destination	Asynchronous motors
Product specific application	Simple machine
Device short name	ATSU01
Network number of phases	3 phases
[Us] rated supply voltage	200...480 V - 10...10 %
Motor power kW	4 kW 3 phases 400 V 1.5 kW 3 phases 230 V
Motor power hp	2 hp 3 phases 230 V 5 hp 3 phases 460 V
IcL starter rating	9 A
Utilisation category	AC-53B EN/IEC 60947-4-2
Current consumption	65 mA
Type of start	Start with voltage ramp
Power dissipation in W	1.5 W at full load and at end of starting 91.5 W in transient state

## Complementary

Assembly style	With heat sink
Function available	Integrated bypass
Supply voltage limits	180...528 V
Supply frequency	50...60 Hz - 5...5 %
Network frequency	47.5...63 Hz
Output voltage	<= power supply voltage
[Uc] control circuit voltage	24 V DC +/- 10 %
Starting time	1 s 100 10 s 10 5 s 20 Adjustable from 1 to 10 s
Deceleration time symb	Adjustable from 1 to 10 s
Starting torque	30...80 % of starting torque of motor connected directly on the line supply

Discrete input type	Logic LI1, LI2, BOOST stop, run and boost on start-up functions <= 8 mA 27 kOhm
Discrete input voltage	24...40 V
Input output isolation	Galvanic between power and control
Discrete input logic	Positive LI1, LI2, BOOST < 5 V and <= 0.2 mA > 13 V >= 0.5 mA
Discrete output current	2 A DC-13 3 A AC-15
Discrete output type	Open collector logic LO1 end of starting signal Relay outputs R1A, R1C NO
Discrete output voltage	24 V 6...30 V open collector logic
Minimum switching current	10 mA 6 V DC relay outputs
Maximum switching current	2 A 30 V DC inductive cos phi = 0.5 20 ms relay outputs 2 A 250 V AC AC-15 inductive cos phi = 0.5 20 ms relay outputs
Maximum switching voltage	440 V relay outputs
Display type	1 LED green starter powered up 1 LED yellow nominal voltage reached
Tightening torque	0.5 N.m 1.9...2.5 N.m
Electrical connection	4 mm screw clamp terminal rigid 1 1...10 mm <sup>2</sup> AWG 8 power circuit Screw connector rigid 1 0.5...2.5 mm <sup>2</sup> AWG 14 control circuit 4 mm screw clamp terminal rigid 2 1...6 mm <sup>2</sup> AWG 10 power circuit Screw connector rigid 2 0.5...1 mm <sup>2</sup> AWG 17 control circuit Screw connector flexible with cable end 1 0.5...1.5 mm <sup>2</sup> AWG 16 control circuit 4 mm screw clamp terminal flexible without cable end 1 1.5...10 mm <sup>2</sup> AWG 8 power circuit Screw connector flexible without cable end 1 0.5...2.5 mm <sup>2</sup> AWG 14 control circuit 4 mm screw clamp terminal flexible with cable end 2 1...6 mm <sup>2</sup> AWG 10 power circuit 4 mm screw clamp terminal flexible without cable end 2 1.5...6 mm <sup>2</sup> AWG 10 power circuit Screw connector flexible without cable end 2 0.5...1.5 mm <sup>2</sup> AWG 16 control circuit
Marking	CE
Operating position	Vertical +/- 10 degree
Height	234 mm
Width	45 mm
Depth	150 mm
Product weight	0.34 kg
Power range	4...6 kW 2.2...3 kW at 380...440 V 3 phases 1.1...2 kW at 200...240 V 3 phases
Motor starter type	Soft starter

## Environment

Electromagnetic compatibility	Damped oscillating waves level 3 IEC 61000-4-12 Electrostatic discharge level 3 IEC 61000-4-2 Immunity to electrical transients level 4 IEC 61000-4-4 Immunity to radiated radio-electrical interference level 3 IEC 61000-4-3 Voltage/Current impulse level 3 IEC 61000-4-5 Conducted and radiated emissions level B CISPR 11 Conducted and radiated emissions level B IEC 60947-4-2 EMC immunity EN 50082-2 Harmonics IEC 1000-3-2 Harmonics IEC 1000-3-4 Conducted and radiated emissions level 3 IEC 61000-4-6 Immunity to conducted interference caused by radio-electrical fields IEC 61000-4-11 EMC immunity EN 50082-1
Standards	EN/IEC 60947-4-2
Product certifications	CCC CSA C-Tick UL
IP degree of protection	IP20
Pollution degree	2 EN/IEC 60947-4-2
Vibration resistance	1.5 mm peak to peak 3...13 Hz EN/IEC 60068-2-6 1 gn 13...150 Hz EN/IEC 60068-2-6
Shock resistance	15 gn 11 ms EN/IEC 60068-2-27

Relative humidity	5...95 % without condensation or dripping water EN/IEC 60068-2-3
Ambient air temperature for operation	-10...40 °C without derating 40...50 °C with current derating of 2 % per °C
Ambient air temperature for storage	-25...70 °C EN/IEC 60947-4-2
Operating altitude	<= 1000 m without derating > 1000 m with current derating of 2.2 % per additional 100 m

### Contractual warranty

Warranty period	18 months
-----------------	-----------

Dimensions

With TeSys U Combination (Non Reversing Power Base)

Mounting on symetrical (35 mm) rail with power connector between ATS and TeSys U.

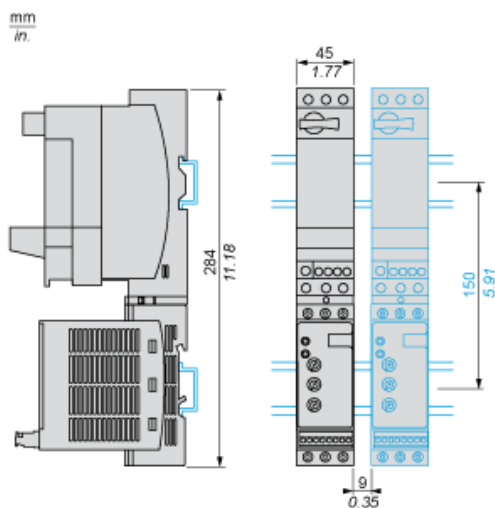

With TeSys U Combination (Non Reversing or Reversing Power Base)

Side by side mounting

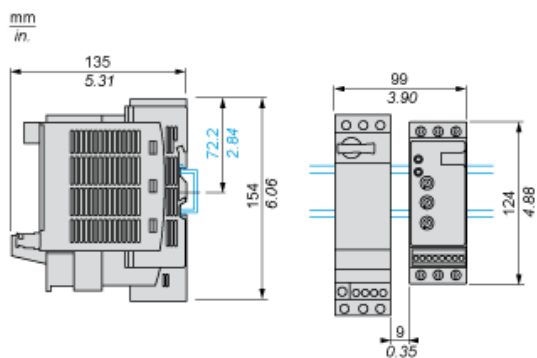

Power Wiring

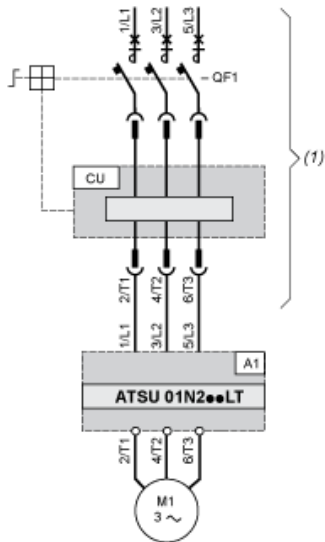

- (1) TeSys U  
 A1 : Soft start/soft stop unit  
 QF1 : TeSys U controller-starter  
 CU : TeSys U control unit

With Reversing Unit

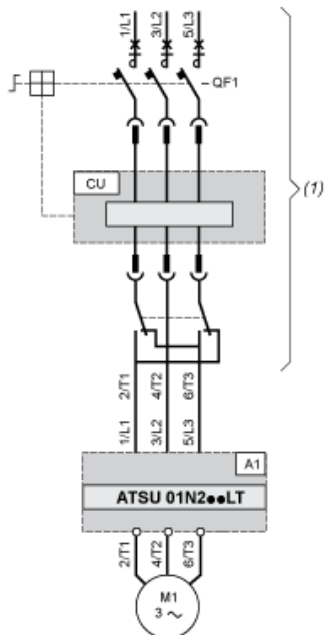

- (1) TeSys U with reversing unit  
 A1 : Soft start/soft stop unit  
 QF1 : TeSys U controller-starter  
 CU : TeSys U control unit

## Control Wiring

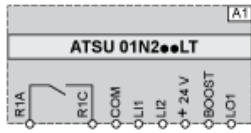

A1 : Soft start/soft stop unit

R1A, R1C Relay output NO

COM : Commun

LI1, LI2 : Logic inputs (stop and run functions)

BOOST : Logic input (boost on start-up function)

LO1 : Logic output

Functional Diagram Automatic 2-wire Control

Without Deceleration

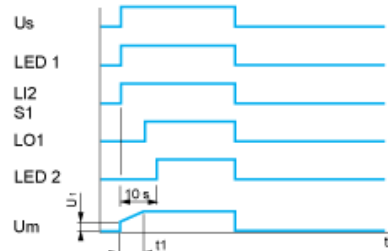

- Us : Power supply voltage
- LED 1 : Green LED
- LI2 : Logic input
- S1 : Pushbutton
- LED 2 : Yellow LED
- Um : Motor voltage
- t1 : Acceleration time can be controlled by a potentiometer
- U1 : Starting time can be controlled by a potentiometer

With and without Deceleration

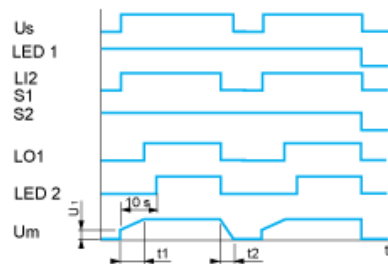

- Us : Power supply voltage
- LED 1 : Green LED
- LI2 : Logic input
- S1, S2 : Pushbuttons
- LO1 : Logic output
- LED 2 : Yellow LED
- Um : Motor voltage
- t1 : Acceleration time can be controlled by a potentiometer
- t2 : Deceleration time can be controlled by a potentiometer
- U1 : Starting time can be controlled by a potentiometer

Functional Diagram Automatic 3-wire Control

Without Deceleration

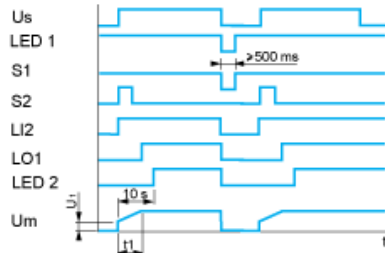

- Us : Power supply voltage
- LED 1 : Green LED
- S1, S2 : Pushbuttons
- LI2 : Logic input
- LO1 : Logic output
- LED 2 : Yellow LED
- Um : Motor voltage
- t1 : Acceleration time can be controlled by a potentiometer
- U1 : Starting time can be controlled by a potentiometer

With Deceleration

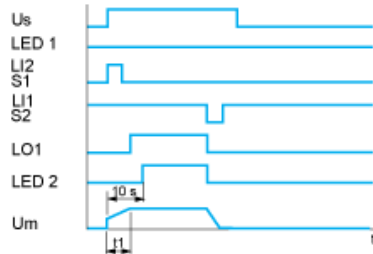

- Us : Power supply voltage
- LED 1 : Green LED
- S1, S2 : Pushbuttons
- LI1, LI2 : Logic inputs
- LO1 : Logic output
- LED 2 : Yellow LED
- Um : Motor voltage
- t1 : Acceleration time can be controlled by a potentiometer