



ENGLISH

Datasheet

3 Phase Multi-function Power Meter 1/5A MID

DIN Rail Power Meter.



CE  RoHS MID



UK

The 871-8308 is a new generation modern design power monitor that will measure and display electrical power quality parameters. It has been engineered to cover most applications (Single Phase and Three Phase networks / Built in Pulsed and RS485 Modbus / Import and Export kWh), replacing the need for several different models of this power meter.

- MID B+D Certified
- Certificate Number 0120/SGS0177
- Class B (kWh) EC Directive 2004/22/EC
- Certified for Single & Three Phase
- Certified for Import / Export kWh

As the demand for MID certified meters has increased, we have obtained annex B and D of the EC Directive 2004/22/EC. This power meter has been tested and certified for single or three phase networks and import and export active energy (kWh).

The 871-8308 is produced to the highest quality and utilizes the latest microprocessor and technology. It has a blue backlit display and 16 different measuring parameters. This includes a negative power reading to indicate reversal of CT installation or connection. With built in pulsed outputs and RS485 Modbus RTU it is fully compatible for integration with BMS and remote monitoring systems.

Parameters

- Phase to Phase Voltage (3p3w Supplies Only)
- Phase to Neutral Voltage
- Frequency
- Voltage Total Harmonic Distortion (THD)
- Current
- Neutral Current (Calculated - Modbus Only)
- Current Max Demand
- Current Total Harmonic (THD)
- kW
- kVA
- kVAr
- Power Max Demand
- Power Factor
- Import kWh
- Export kWh
- Import kVarh
- Export kVarh

Specifications

Measured Parameters

The unit can monitor and display the following parameters of a single phase two wire (1p2w), three phase three wire (3p3w) or three phase four wire (3p4w) system.

Voltage and Current

- Phase to neutral voltages 100 to 289V a.c. (not for 3p3w supplies).
- Voltages between phases 173 to 500V a.c. (3p3w supplies only).
- Percentage total voltage harmonic distortion (THD%) for each phase to N (not for 3p3w supplies).
- Percentage voltage THD% between phases (3p3w supplies only).
- Current THD% for each phase

Power factor and Frequency and Max. Demand

- Frequency in Hz
- Instantaneous power:
- Power 0 to 3600 MW
- Reactive power 0 to 3600 MVA
- Volt-amps 0 to 3600 MVA
- Maximum demanded power since last Demand reset Power factor
- Maximum neutral demand current, since the last Demand reset (for three phase supplies only)

Interfaces for External Monitoring

Three interfaces are provided:

- RS485 communication channel that can be programmed for Modbus RTU protocol
- Relay output indicating real-time measured energy. (configurable)
- Pulse output 3200imp/kWh (not configurable)

The Modbus configuration (baud rate etc.) and the pulse relay output assignments (kW/kVArh, import/export etc.) are configured through the set-up screens.

Pulse Output

Opto-coupler with potential free SPST-NO Contact (Contact range 5-27VDC / Max current input: I_{min} 2mA and I_{max} 27mA DC).

The pulse output can be set to generate pulses to represent kWh or kVArh.

Rate can be set to generate 1 pulse per:



0.01 = 10 Wh/VArh
 0.1 = 100 Wh/VArh
 1 = 1 kWh/kVArh
 10 = 10 kWh/kVArh
 100 = 100 kWh/kVArh
 Pulse width 200/100/60 ms.

RS485 Output for Modbus RTU

For Modbus RTU, the following RS485 communication parameters can be configured from the set-up menu:

Baud rate 2400, 4800, 9600, 19200, 38400
 Parity none (default) / odd / even
 Stop bits 1 or 2
 RS485 network address nnn – 3-digit number, 1 to 247
 Modbus™ Word order Hi/Lo byte order is set automatically to normal or reverse. It cannot be configured from the set-up menu.

Energy Measurements

Imported/Exported active energy	0 to 9999999.9 kWh
Imported/Exported reactive energy	0 to 9999999.9 kVArh
Total active energy	0 to 9999999.9 kWh
Total reactive energy	0 to 9999999.9 kVArh

Auxiliary Supply

Two-way fixed connector with 2.5mm² stranded wire capacity. 85 to 275V a.c. 50/60Hz ±10% or 120V to 380V d.c. ±20%. Consumption <2W 10VA.

Operating range	87...275VAC ±10% / 120....380VDC ±20%
-----------------	---------------------------------------

Measured Inputs

Voltage inputs through 4-way fixed connector with 2.5mm² stranded wire capacity. single phase two wire(1p2w), three phase three wire(3p3w) or three phase four wire(3p4w) unbalanced. Line frequency measured from L1 voltage or L3 voltage. Three current inputs (six physical terminals) with 2.5mm² stranded wire capacity for connection of external CTs. Nominal rated input current 5A or 1A a.c. Rms.

Nominal Voltage Input	(Ph+N) 100 to 289V (Ph+Ph) 173 to-500V
Max Continuous Voltage	120% of nominal
Nominal Input Current	0.25-5A(6)A AC rms
Max Continuous Current	120% of nominal
Nominal Input Current Burden	0.5VA
Frequency	45-65Hz

Accuracy

Voltage	0.5% of range maximum
Current	0.5% of nominal
Frequency	0.2% of mid-frequency
Power factor	1% of unity (0.01)
Active power (W)	±1% of range maximum
Reactive power (VAr)	±1% of range maximum
Apparent power (VA)	±1% of range maximum
Active energy (Wh)	Class 1 IEC 62053-21
Reactive energy (VArh)	±1% of range maximum
Total harmonic distortion	1% up to 31st harmonic
Response time to step input	1s, typical, to >99% of final reading, at 50 Hz.

Reference Conditions of Influence Quantities

Influence Quantities are variables that affect measurement errors to a minor degree. Accuracy is verified under nominal value (within the specified tolerance) of these conditions.

Ambient temperature	23°C ±1°C
Input waveform	50 or 60Hz ±2%
Input waveform	Sinusoidal (distortion factor < 0.005)
Auxiliary supply voltage	Nominal ±1%
Auxiliary supply frequency	Nominal ±1%
Auxiliary supply waveform (if AC)	Sinusoidal (distortion factor < 0.05)
Magnetic field of external origin	Terrestrial flux

Environment

Operating temperature	-25°C to +55°C*
Storage temperature	-40°C to +70°C*
Relative humidity	0 to 95%, non-condensing
Altitude	Up to 3000m
Warm up time	1 minute
Vibration	10Hz to 50Hz, IEC 60068-2-6, 2g
Shock	30g in 3 planes

*Maximum operating and storage temperatures are in the context of typical daily and seasonal variation.

Mechanics

DIN rail dimensions	72 x 94.5 mm (WxH) per DIN 43880
Mounting	DIN rail (DIN 43880)
Sealing	IP51 indoor
Material	Self-extinguishing UL 94 V-0

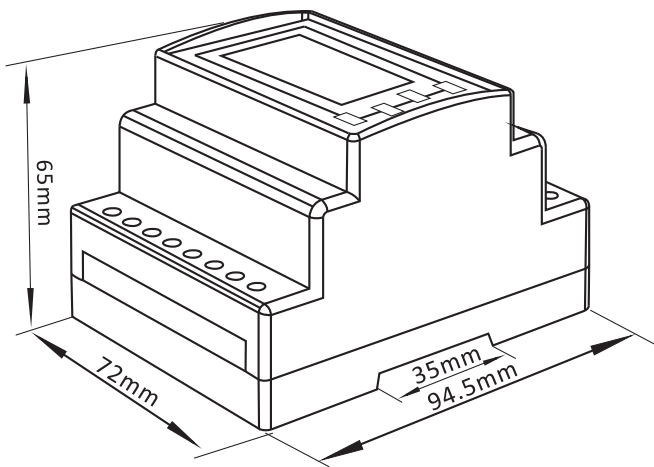

Installation

Single Phase, Two Wire (1p2w)

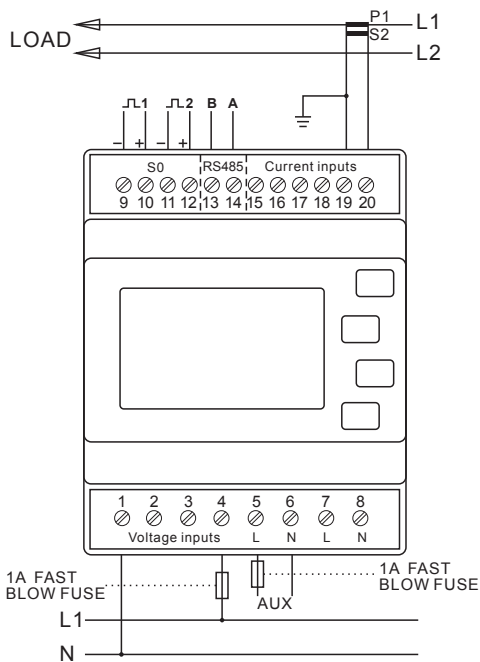

Three Phase, Three Wire (3p3w)

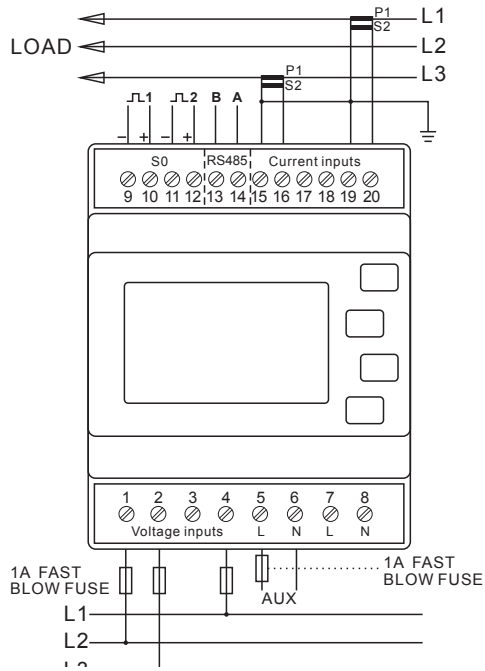

Three Phase, Four Wire (3p4w)

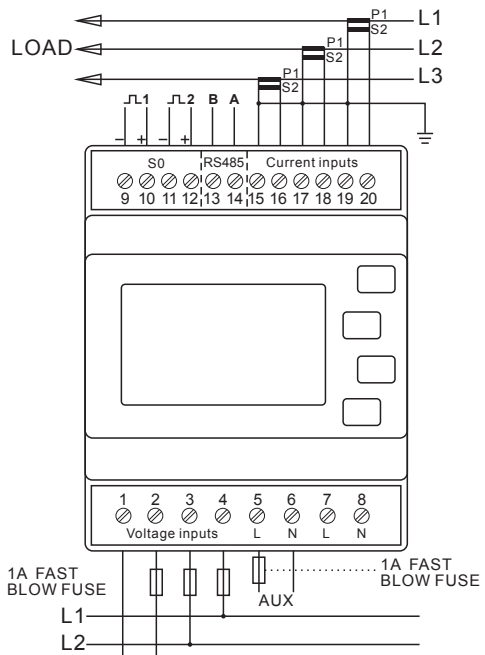

Specifications are subject to change without notice.