

WIZ100SR User's Manual

(Version 1.0)

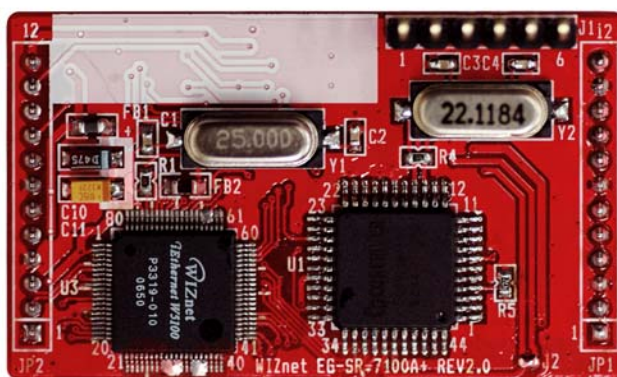

©2007 WIZnet Co., Inc. All Rights Reserved.

For more information, visit our website at <http://www.wiznet.co.kr>

WIZnet's Online Technical Support

If you have something to ask about WIZnet products, write down your question on Q&A Board in WIZnet website (www.wiznet.co.kr). WIZnet will give an answer as soon as possible.

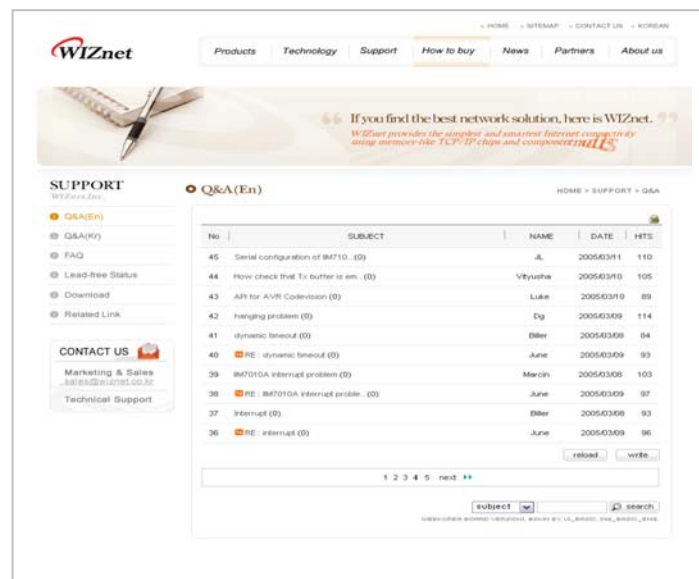
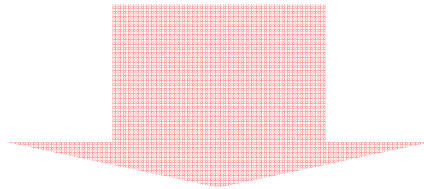
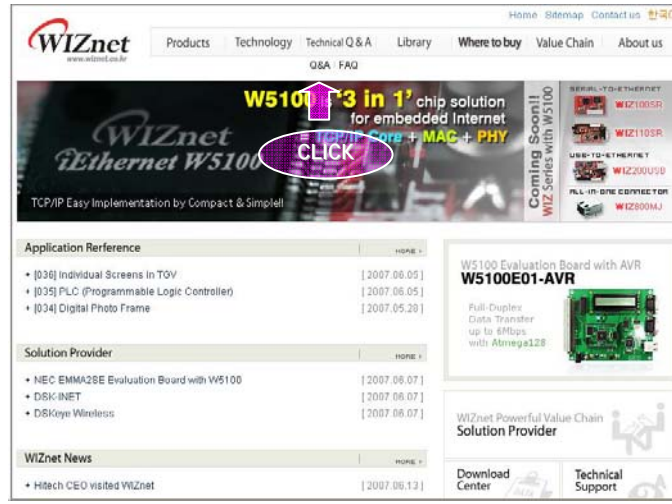

COPYRIGHT NOTICE

Copyright 2007 WIZnet, Inc. All Rights Reserved.

Technical Support: support@wiznet.co.kr

Sales & Distribution: sales@wiznet.co.kr

For more information, visit our website at <http://www.wiznet.co.kr>

Table of Contents

1.	Introduction	1
1.1.	Products Contents (EVB model)	1
1.2.	Products Specification	2
1.2.1.	WIZ100SR Module	2
1.2.2.	WIZ100SR Test Board	3
1.2.2.1.	Serial Interface.....	4
1.2.2.2.	LED	4
2.	Getting Started	5
2.1.	Hardware Installation Procedure	5
2.2.	Configuration Tool	6
2.2.1.	Network Configuration	6
2.2.2.	Serial configuration	11
2.2.3.	Option configuration	11
3.	Firmware Upload.....	14
4.	Serial Configuration	16
4.1.	Serial Command mode	16
4.2.	Chaning IP address by Using Command mode.....	17
5.	PIN Assignment and Dimension	22
6.	Demonstration and Test.....	25
7.	Reference Schematic	31

Figures

FIG 1 WIZ100SR TEST BOARD.....	3
FIG 2 SERIAL PIN ASSINGMENT OF WIZ100SR TEST BOARD.....	4
FIG 3 SERIAL CABLE	4
FIG 4 CONFIGURATION TOOL (NETWORK CONFIG)	6
FIG 5 TCP SERVER MODE	8
FIG 6 TCP CLIENT MODE	8
FIG 7 UDP MODE	10
FIG 8 CONFIGURATION TOOL (SERIAL CONFIG.)	11
FIG 9 CONFIGURATION TOOL (OPTION CONFIG.)	12
FIG 10 BOARD SEARCH WINDOW.....	14
FIG 11 OPEN DIALOG BOX FOR UPLOADING.....	15
FIG 12 FIRMWARE UPLOADING WINDOW.....	15
FIG 13 COMPLETE UPLOADING.....	15
FIG 14 WIZ100SR PIN ASSIGNMENT	22
FIG 15 WIZ100SR DIMENSION.....	24
FIG 16 DATA FLOW (SERIAL -> ETHERNET).....	25
FIG 17 DATA FLOW (ETHERNET -> SERIAL).....	26
FIG 18 RESULT WINDOW AFTER RUNNING “SETTING”	27
FIG 19 SERIAL TERMINAL PROGRAM CONFIGURATION	28
FIG 20 NETWORK TERMINAL PROGRAM CONFIGURATION	28
FIG 21 RECEIVED DATA BY NETWORK TERMINAL PROGRAM.....	29
FIG 22 DEVICE TERMINAL PROGRAM	30





Tables

TABLE 1 WIZ100SR MODULE SPECIFICATION	3
TABLE 2 SERIAL PIN DESCRIPTION	4
TABLE 3 WIZ100SR PIN FUNCTIONS.....	23
TABLE 4 WIZ100SR DIMENSION.....	24

1. Introduction

WIZ100SR is a gateway module that converts RS-232 protocol into TCP/IP protocol. It enables remote gauging, managing and control of a device through the network based on Ethernet and TCP/IP by connecting to the existing equipment with RS-232 serial interface. In other words, WIZ100SR is a protocol converter that transmits the data sent by serial equipment as TCP/IP data type and converts back the TCP/IP data received through the network into serial data to transmit back to the equipment

1.1. Products Contents (EVb model)

	<p>WIZ100SR Module</p>
	<p>WIZ100SR Test Board</p>
	<p>Serial Cable (to connect Serial device and Test board)</p>
	<p>Network Cable (Crossover Cable)</p>

	<p>Power (DC 5V 500mA Adaptor)</p>
	<p>CD (including Manual, H/W Schematic and S/W)</p>

1.2. Products Specification

1.2.1. WIZ100SR Module

Category	Specification
Protocol	TCP, UDP, IP, ARP, ICMP, IGMP, Ethernet MAC, PPPoE
Network Interface	10/100 Base-T Ethernet (Auto detection)
Serial Port	1 RS-232 port (3.3V LVTTTL)
CPU	8051 compatible
Serial line format	8-N-1, 8-O-1, 8-E-1, 7-O-1, 7-E-1
Serial flow control	None, XON/XOFF, CTS/RTS
Serial signal	TXD, RXD, RTS, CTS, DTR, DSR, GND
Software	Remote Downlod and Configuration
Serial Transmission Speed	1200bps ~ 230Kbps
Memory	Internal Memory (62KB Flash Memory, 2KB EEPROM, 16KB SRAM)
Temperature	10°C ~ 80°C (Operating), -40~85°C (Storage)
Humidity	10~90%
Power	3.3V, 150mA

Connector type	2x12 2mm Pin header array
Size	50mm x 30mm x 8.85mm

Table 1 WIZ100SR Module Specification

1.2.2. WIZ100SR Test Board

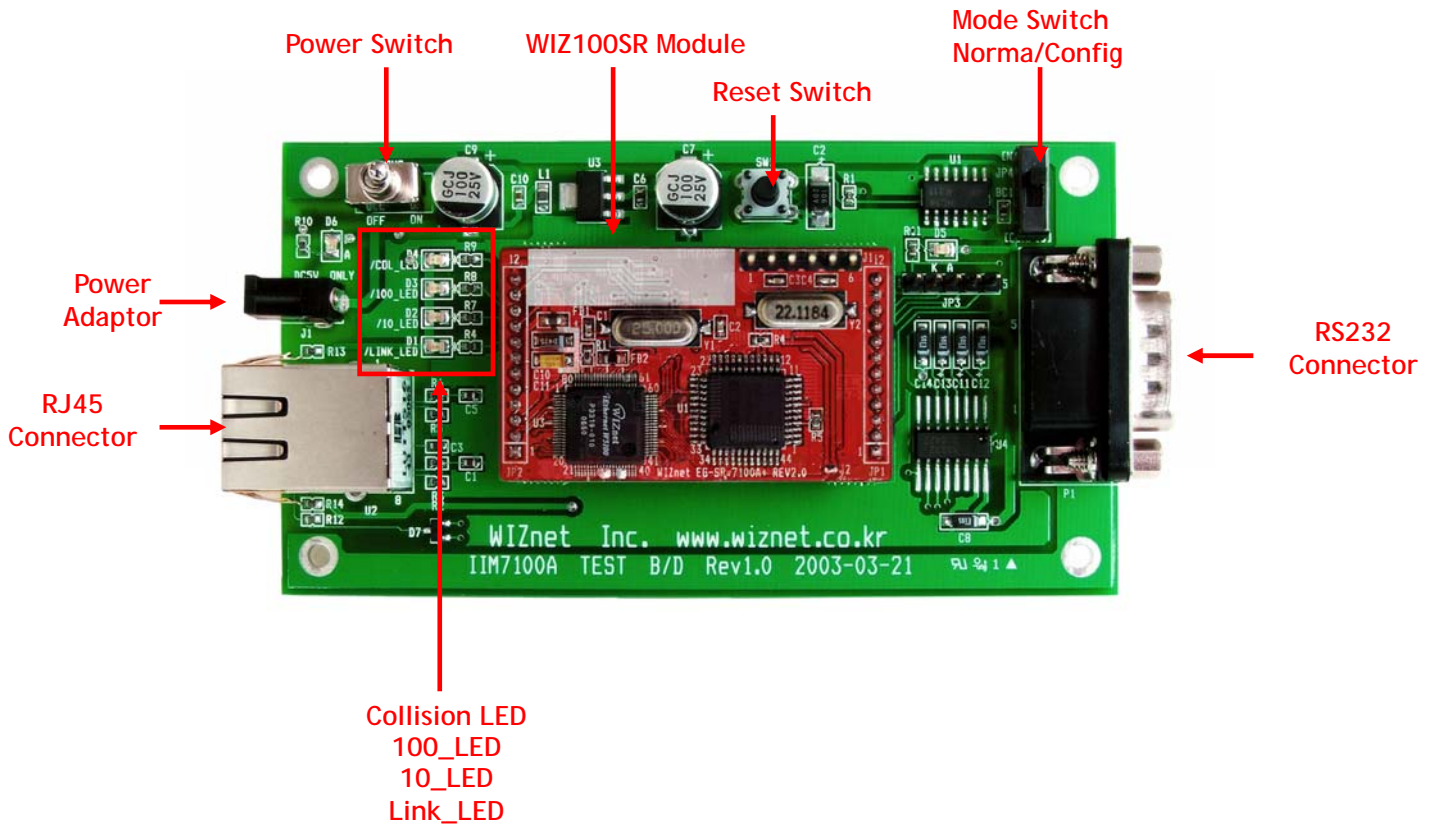

Fig 1 WIZ100SR Test Board

☞ NOTE : Be careful of setting Mode Switch. If Mode Switch is set as Config mode, the network function is not normally operating. For the function test, set it as Normal mode.
 ➔ If LED(D5) is on, it indicates that network is connected or Config mode is set.

1.2.2.1. Serial Interface

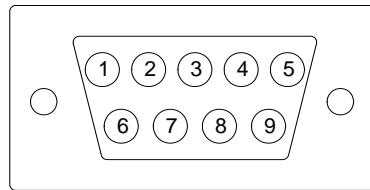

Fig 2 Serial Pin Assingment of WIZ100SR Test Board

Pin Number	Signal	Description
1	NC	Not Connected
2	RxD	Receive Data
3	TxD	Transmit Data
4	DTR	Data Terminal Ready
5	GND	Ground
6	DSR	Data Set Ready
7	RTS	Request To Send
8	CTS	Clear To Send
9	NC	Not Connected

Table 2 Serial Pin Description

- RxD, TxD, GND : These are all you need if the device does not use hardware handshaking.
- RxD, TxD, GND, RTS, CTS : These are the signals used when serial device uses hardware handshaking.
- DTR, DSR : not used

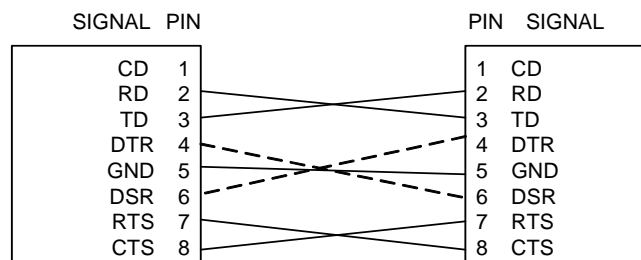

Fig 3 Serial Cable

1.2.2.2. LED

- Power LED: displays power stauts of WIZ100SR

- Link LED: indicates network link is established
- 10 LED: indicates network speed is 10Mbps
- 100 LED: indicates network speed is 100Mbps
- Collision LED: indicates a packet transmitted from the Ethernet controller to the network has collided with another packet

2. Getting Started

2.1. Hardware Installation Procedure

For the testing, module and test board should be prepared.

- **STEP1:** Plug the WIZ100SR module into the sockets on the test board.
 - ☞ Be careful of connecting the JP1 on the module to the correct JP1 on the test board.
 - ☞ Use test board rev 2.0 or above for WIZ100SR testing.
- **STEP2:** Connect the RJ-45 connector of WIZ100SR test board to the Ethernet hub or LAN port of PC.
- **STEP3:** Connect the DB9 jack of WIZ100SR and serial device with RS-232 serial line.
- **STEP4:** Connect the 5V (500mA) DC power adaptor to the WIZ100SR test board.
The power used for WIZ100SR is 3.3V.

2.2. Configuration Tool

2.2.1. Network Configuration

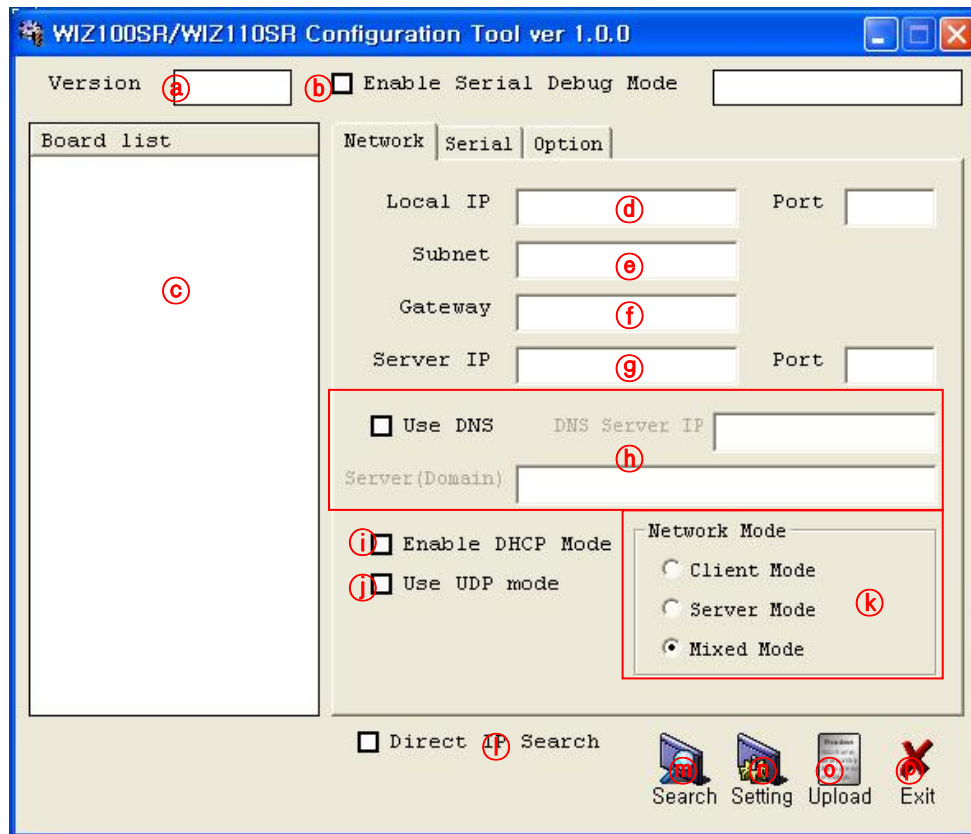

Fig 4 Configuration Tool (Network Config)

Ⓐ Version : Displays firmware version

Ⓑ Enable Serial Debug Mode : If this mode is checked, you can monitor the status and socket message of WIZ100SR (listen OK, connect fail etc.) through serial terminal. If Debug mode is on, debug message can cause abnormal operation of the serial device. Therefore, just use this mode only for Debug mode.

Ⓒ Board List : If you click "Search" button, all the mac addresses on a same subnet, will be displayed.

Ⓓ Local IP/Port : WIZ100SR's IP address and Port number for network connection

Ⓔ Subnet : WIZ100SR's subnet mask

㉑ Gateway : WIZ100SR's Gateway address

㉒ Server IP/Port : When WIZ100SR is set as "Client mode" or "Mixed mode", server IP and port should be set. WIZ100SR attempts to connect this IP address.

㉓ Use DNS :

If DNS function is needed, check this option and input the domain name of DNS server. DNS(Domain Name System) is the database system having information about IP address and corresponding domain name. When connecting to domain name, you can use DNS function of WIZ100SR. Input IP address of DNS server provided by ISP in *DNS Server IP*, and domain name in the *Server (Domain)*

㉔ Enable DHCP Mode :

Set this option to use DHCP mode. First, check 'Enable DHCP mode' and click 'Setting' button. If IP address is successfully acquired from DHCP server, the MAC address will be displayed on the board list. (It takes some time to acquire IP address from DHCP server)

When a module on the board list is selected, IP address, Subnet mask and Gateway are displayed. If module could not acquire network information from DHCP server, IP address, Gateway Address and Subnet mask will be initialized to 0.0.0.0.

㉕ Network mode: client/server/mixed

This is to select the communication method based on TCP - TCP Server, TCP Client, and Mixed. TCP is the protocol to establish the connection before data communication, but UDP just proceeds the data communication without connection establishment.

TCP Server operates as a server and TCP Client as a client on the connection establishment. The mixed mode supports both of TCP server and client.

☞ This Network mode is just related to the connection establishment process. It just defines who will request the connection first and who will be waiting for the connection requests.

<TCP server mode>

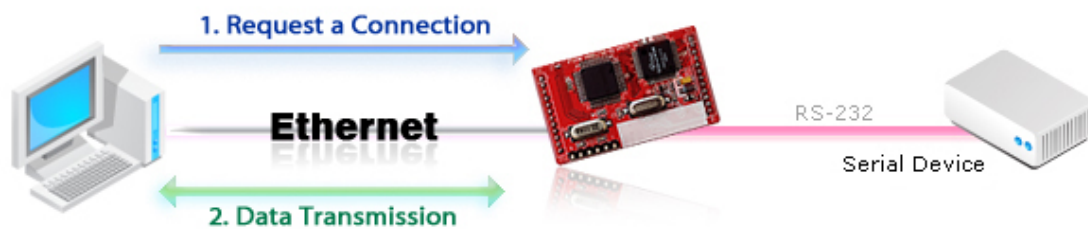

Fig 5 TCP Server mode

At the TCP Server mode, WIZ100SR waits for the connection requests.

TCP Server mode can be useful when the monitoring center tries to connect to the device (WIZ100SR is installed) in order to check the status or provide the commands. In normal time WIZ100SR is on the waiting status, and if there any connection request from the monitoring center, data communication is processed and connection is closed.

In order to operate this mode, Local IP, Subnet, Gateway Address and Local Port Number should be configured first.

As illustrated in the above figure, data transmission proceeds as follows,

1. The host connects to the WIZ100SR which is configured as TCP Server mode.
2. As the connection is established, data can be transmitted in both directions - from the host to the WIZ100SR, and from the WIZ100SR to the host

<TCP client mode>

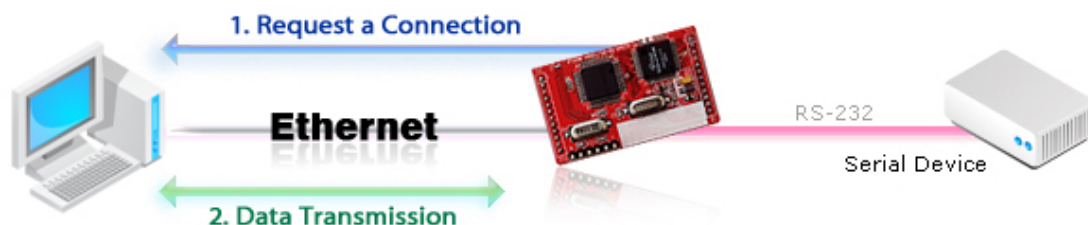

Fig 6 TCP Client mode

If WIZ100SR is set as TCP Client, it tries to establish connection to the server.

To operate this mode, Local IP, Subnet, Gateway Address, Server IP, and Server port number should be set. If server IP had domain name, user DNS function.

In TCP Client mode, WIZ100SR can actively establish a TCP connection to a host computer when power is supplied.

As illustrated in the figure, data transmission proceeds as follows:

1. As power is supplied, WIZ100SR board operating as TCP client mode actively establishes a connection to the server.
2. If the connection is complete, data can be transmitted in both directions - from the host to the WIZ100SR and from WIZ100SR to the host

<Mixed mode>

In this mode, WIZ100SR normally operates as TCP Server and waits for the connection request from the peer. However, if WIZ100SR receives data from the serial device before connection is established, it changes to the client mode and sends the data to the server IP. Therefore, at the mixed mode, the server mode is operated prior to the client mode.

As like TCP Server mode, the Mixed mode is useful for the case that the monitoring center tries to connect to the serial device (in which WIZ100SR is plugged) to check device status. In addition to this, if any emergency occurs in the serial device, the module will change to Client mode to establish the connection to the server and deliver the emergency status of the device.

Ⓚ Use UDP mode

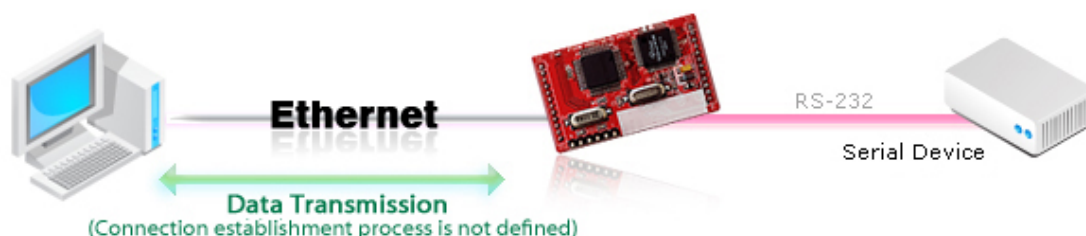

Fig 7 UDP mode

At the UDP mode, the connection establishment is not defined. Just set the IP address and port number of the peer and send the data.

① Direct IP Search

Direct IP Search can be used for searching WIZ100SR not installed in the same subnet.

If the Direct IP search is checked, the configuration tool use the TCP instead UDP broadcast to search modules. Therefore, network information of the module such as IP address, subnet mask and gateway is required.

If you check Direct IP search, the field to input IP address will be activated. In this field, input IP address of the module, and click "Search" button.

☞ **If module does not have valid network information, Direct IP search is not available.**

② Search

The Search function is used to search all modules existing on the same LAN. By using UDP broadcast, all modules on the same subnet will be searched.

The searched module is displayed as MAC address in the "Board list".

③ Setting

This function is to complete the configuration change.

If you select the MAC address from the "Board list", the default configuration value of the module will be displayed. Change the configuration and click "Setting" button to complete the configuration. The module will re-initialize with the changed configuration.

The configuration value can be changed in below steps.

- ① Select the mac address of which configuration value should be changed in the "Board list".
The values configured will be displayed.
- ② Change the value
- ③ Click "Setting" button. The configuration change will be complete.
- ④ The module will be initialized to the changed values (re-booting is processed)

④ Upload

Firmware will be uploaded through network

☞ **After uploading the firmware, 20-30 seconds are required for initialization.**

⑤ Exit : Close the Configuration tool program.

2.2.2. Serial configuration

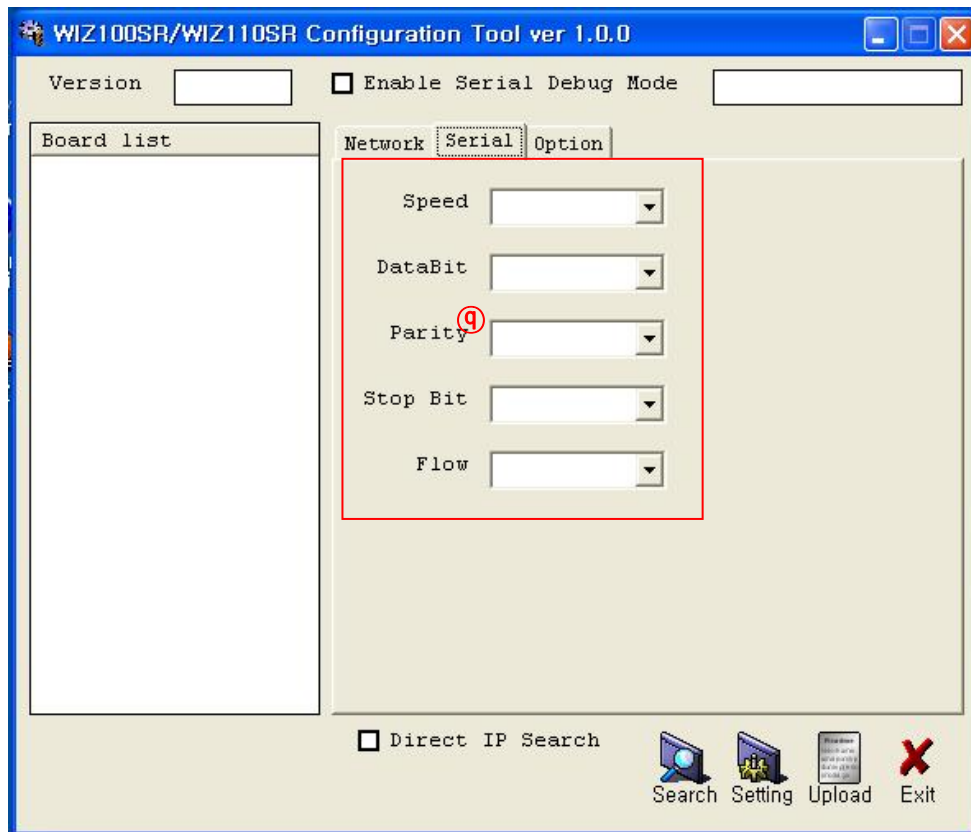

Fig 8 Configuration Tool (Serial Config.)

⑨ Serial

Serial Configuration value of selected module is displayed.

In order to change the serial configuration of WIZ100SR, this menu can be used.

☞ **By clicking the "Setting" button, changed value can be applied.**

2.2.3. Option configuration

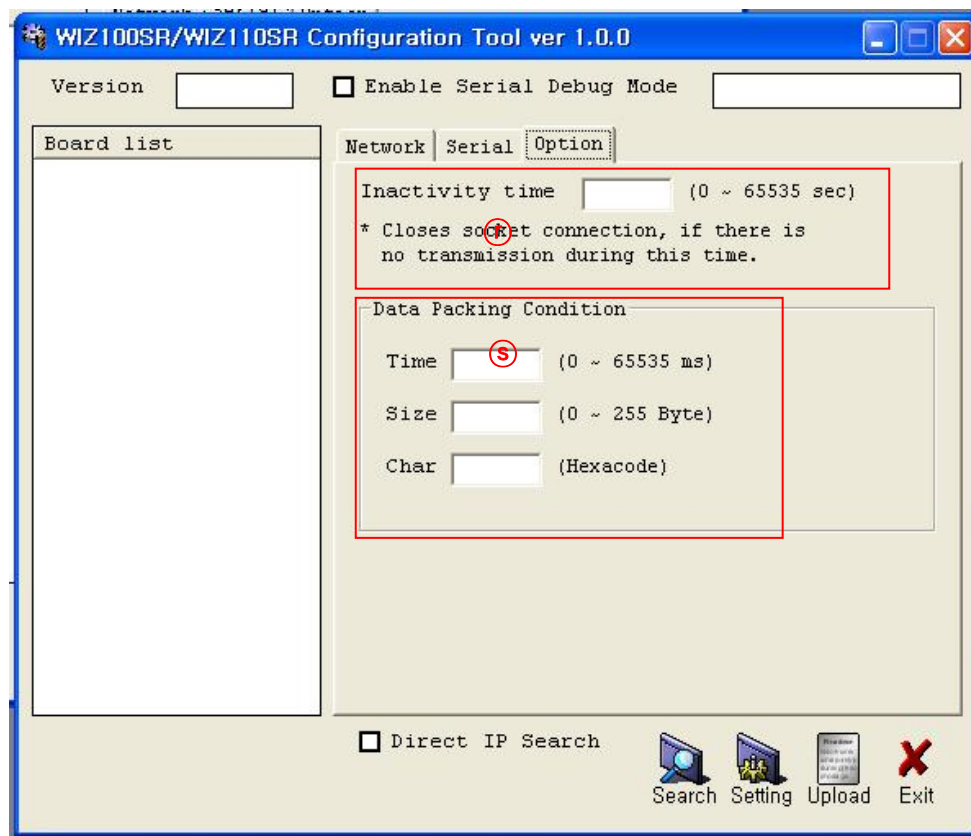

Fig 9 Configuration Tool (Option Config.)

① Inactivity time

After the connection is established, if there is not data transmission within the time defined in Inactivity time, the connection is closed automatically.

The default value is '0'. If '0' is set, this function is not activated. In this default setting, the connection is maintained even though there is no data transmission. In order to close the connection, the 'Close' command should be given.

This function can be used for more than two or more systems to connect to a WIZ100SR module. If one system keeps connection to the WIZ100SR, other systems can not connect to the module. If there is no data transmission during the time defined in Inactivity time, the connection will be closed for other system to be connected.

Inactivity Time can be useful for the case when the server system is unexpectedly shut down. In this status, if there is not any data communication during the time defined in the Inactivity time, WIZ100SR will close the connection and enter into waiting status.

⑤ Data Packing Condition

You can designate how the serial data can be packed to be sent to the Ethernet. There are 3 delimiters - time, size and character. If all of them are set as '0', whenever the serial data is arrived, they are sent to the Ethernet.

- a. Time: Every designated time, serial data converted to Ethernet.
- b. Size: Every designated data size, serial data converted to Ethernet.
- c. Char: Every designated character, serial data converted to Ethernet. (It's available only Hex.)

When any of three delimiters is satisfied, data can be sent to the Ethernet.

Ex) Delimiter: Size=10, Char=0x0D

Serial data : 0123456789abc

Ethernet data : 0123456789

☞ "abc" data remains in the serial buffer of module

3. Firmware Upload

- ① Run 'WIZ100SR/WIZ110SR Configuration Tool' program, and click "Search" button.
- ② If the module is properly connected to the network, "Searching Complete" message and MAC address will be displayed on the "Board List" as shown in Fig.10.

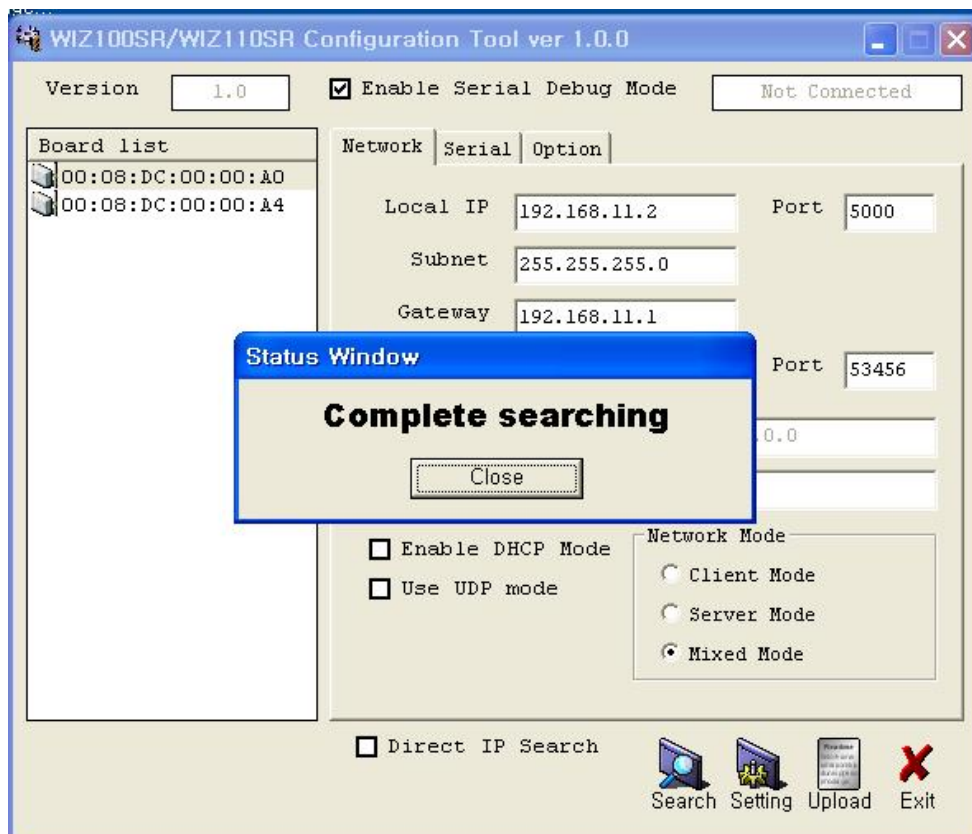

Fig 10 Board Search Window

- ③ Select a module shown in "Board list", and click "Upload" button.
⚠ Before uploading through Ethernet, you should set the network information of WIZ100SR first by Configuration Tool program as shown above Fig 10. By using Ping test, you can check if network is correctly configured.
- ④ When the window as shown in Fig 11 is displayed, select file to upload and click "Open" button.

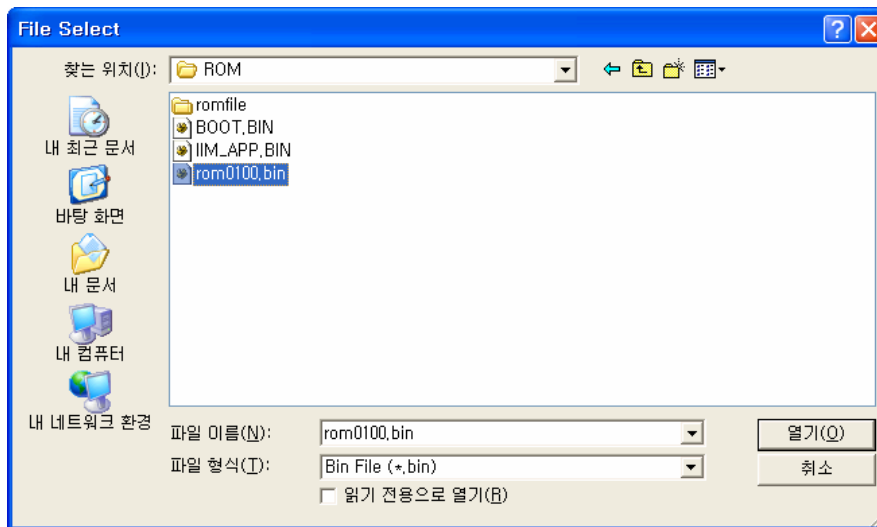

Fig 11 Open dialog box for uploading

⚠ Do not upload any other files except for WIZ100SR application firmware file.

⑤ A dialogue box titled “Processing” will be displayed as below.

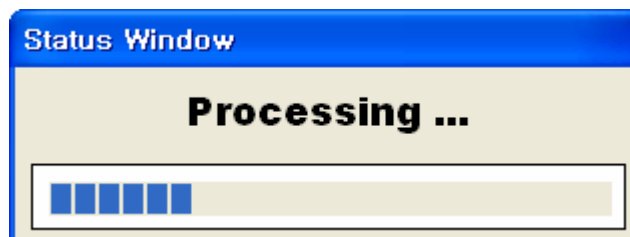

Fig 12 Firmware uploading window

⑥ When uploading is complete, a message box with “Complete Uploading” will be displayed as shown in Fig 3.4.



Fig 13 Complete Uploading

4. Serial Configuration

4.1. Serial Command mode

You can configure WIZ100SR by serial command.

For the serial configuration, enter into the serial configuration mode by setting the JP4 of the test board as config mode, or low the pin of JP1.12 of the module.

If module is entered into serial configuration mode, below message is displayed at the serial terminal.

```
WIZ100SR Ver. 01.00
;
```

In order to change any configuration of WIZ100SR, refer to below command format and execute the related commands. However, it is not possible to change the MAC Address.

	Command	Reply
READ	;>R[CR]	<S[Config contents]
WRITE	<S	
EXIT	<S (then reboot)	

*[CR]: Carriage return

The contents of configuration have following meanings. Below is the default value.

Value(byte)	Description
0008DCxxxxxx(6)	MAC Address (xxxxxx is unique factory value)
01 (1)	Mode (MIXED mode: 01, SERVER mode: 02, Client mode: 00)
00000000 (4)	IP address
00000000 (4)	Subnet mask
00000000 (4)	Gateway address
0000 (2)	Local Port Number (Module's Port Number)
00000000 (4)	Server IP address
0000 (2)	Server Port Number

FE (1)	Serial speed(bps) default is FE								
	BB: 230400	FF: 115200	FE: 57600	FD: 38400	FA: 19200	F4: 9600	E8: 4800	D0: 2400	A0: 1200
08 (1)	Serial data size (08: 8 bit), (07: 7 bit)								
00 (1)	Parity (00: No), (01: Odd), (02: Even)								
01 (1)	Stop bit								
00 (1)	Flow control (00: None), (01: XON/XOFF), (02: CTS/RTS)								
00 (1)	Delimiter char								
0000 (2)	Delimiter size								
0000 (2)	Delimiter time								
0000 (2)	Delimiter idle time								
00 (1)	Debug code (00: ON), (01: OFF)								
01 (1)	Software major version								
00 (1)	Software minor version								
00 (1)	DHCP Option (00: DHCP OFF, 01:DHCP ON)								
00 (1)	UDP mode (00: TCP; 01: UDP)								
00 (1)	Connection Status (00: not connected, 01: connected)								
00 (1)	DNS Flag (00:not use DNS, 01:use DNS)								
00000000 (4)	DNS Server IP address								
00.....00 (32)	Server Domain Name								
00 (1)	Reserved Byte								

4.2. Changing IP address by Using Command mode.

STEP 1. Install WIZ100SR on the test board, and connect power cable and serial cable.

STEP 2. Execute the serial terminal program (Ex. Hyper Terminal), and set the serial configuration such as Baud rate

STEP 3. Reboot the module in serial command mode. For the serial command mode, check if JP4 switch of test board is set as config mode or the pin of JP1.12 is low.

STEP4. If WIZ100SR is entered in the serial command mode, below message is displayed at the serial terminal program.

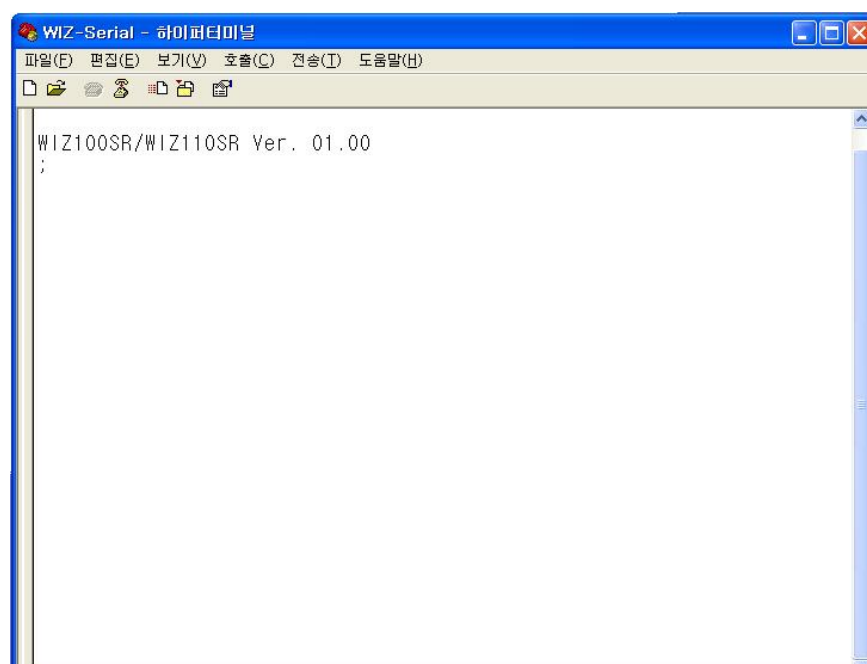

STEP 5. In order to check current IP address, input the read command ">R". The input command is not displayed in the screen.

STEP 6. If you input the command, the respond code, "<S" , and set value is displayed. In below screen, IP address value is from 8th byte to 11th byte. COA80B02, the hexadecimal can be converted to the decimal, 192(0xC0) 168(0xA8) 11(0x0B) 2(0x02)

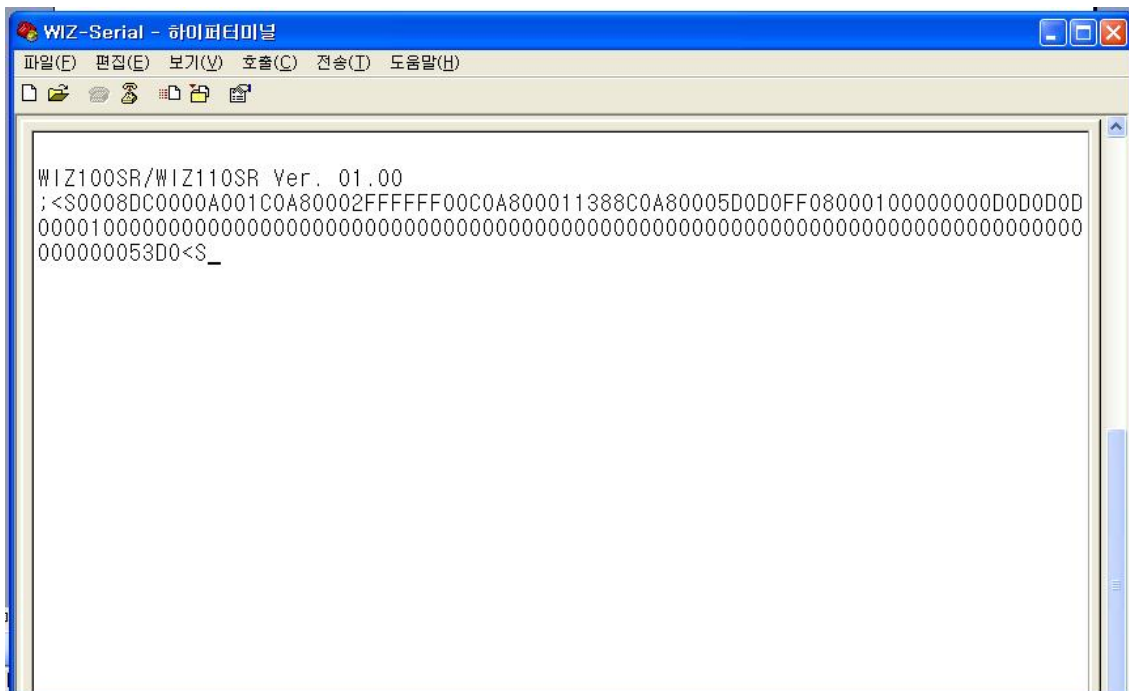

STEP 8. In order to check if IP is successfully changed, input the read command ">R".

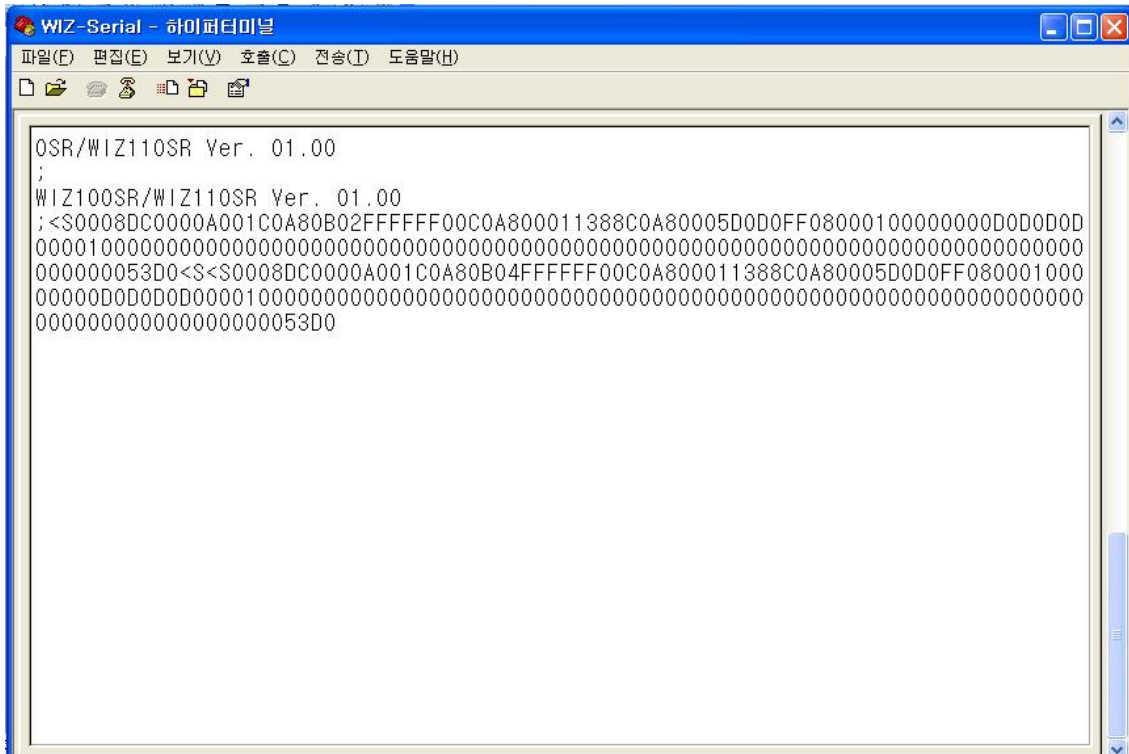

STEP 9. After finishing the configuration by using serial command, be sure to operate the Hardwired Internet Connectivity Wizard (WIZnet, Inc.)

module at the NORMAL mode. For the NORMAL mode, configure JP4 of the test board as normal mode or the pin of JP1.12 as high.

☞At the serial command mode(CONFIG MODE), data communication through network is not available

5. PIN Assignment and Dimension

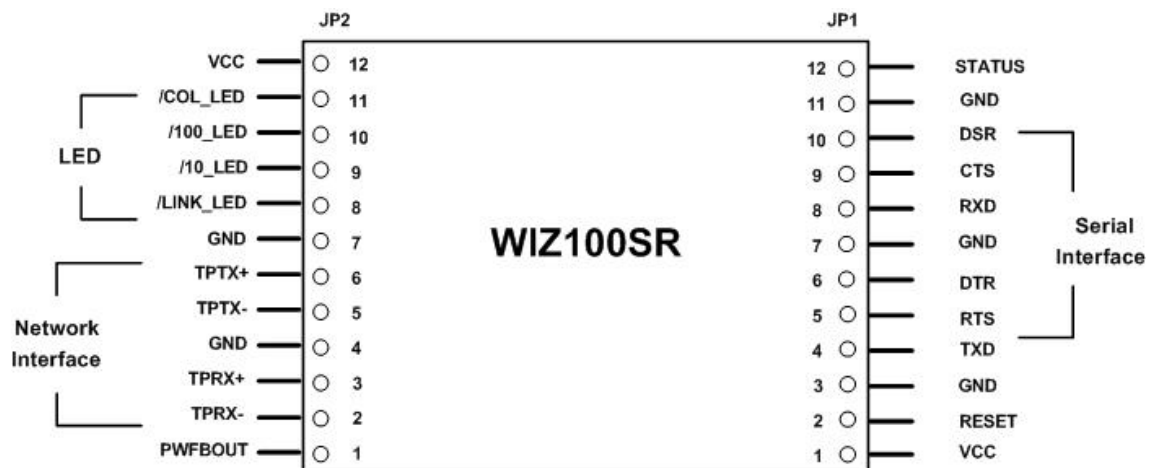

Fig 14 WIZ100SR Pin Assignment

PIN NAME	Functions	I/O	
RESET	Reset (Active High)	Input	
TXD	RS-232 Data Output	Output	
RTS	RS-232 Request To Send	Output	Optional
DTR	RS-232 Data Terminal Ready	Output	Optional
RXD	RS-232 Data Input	Input	
CTS	RS-232 Clear To Send	Input	Optional
DSR	RS-232 Data Set Ready	Input	Optional
TPRX-	Ethernet Differential Input-	Input	
TPRX+	Ethernet Differential Input+	Input	
TPTX-	Ethernet Differential Output-	Output	
TPTX+	Ethernet Differential Output+	Output	
/LINK_LED	Link LED	Output	
/10_LED	10 Mbps LED	Output	

/100_LED	100 Mbps LED	Output	
/COL_LED	Collision LED	Output	
Status	High: Not connected Low: Connected	Output	
PWFBOUT	Power Feedback Out	Output	
VCC	3.3V Power	Power	

Table 3 WIZ100SR PIN Functions

- 1) All signal level is 3.3V LVTTTL.
- 2) A high on RESET pin about minimum 1.2 usec must be applied for proper operation.
- 3) 'Connected' of Status pin means the TCP socket of WIZ100SR is connected to remote system.
- 4) /LINK_LED pin is used to check if Ethernet cable is physically connected or not.

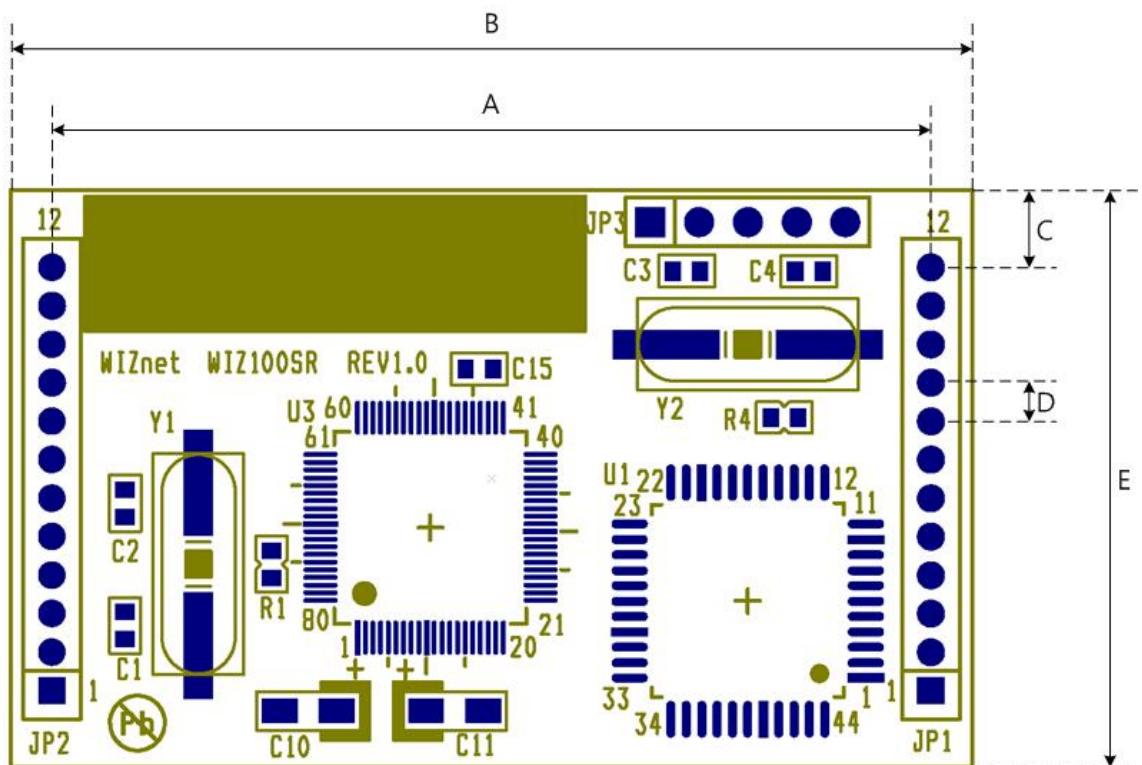

Fig 15 WIZ100SR Dimension

Symbol	Dimension(mm)
A	45.7
B	50.0
C	4.0
D	2.0
E	30.0

Table 4 WIZ100SR Dimension

6. Demonstration and Test

In this chapter, we give an example that can be used to test the function of WIZ100SR.

The testing environment is as follows;

Hardware

- ◆ PC that has an RS-232 serial port.
- ◆ WIZ100SR Test Board
- ◆ Ethernet cross-over cable to connect PC's and LAN Port of WIZ100SR Test Board.
- ◆ RS-232 cable to connect PC's COM port with serial data port of WIZ100SR Test Board.

Software

- ◆ Windows operating system installed on testing PC.
- ◆ WIZ100SR Configuration tool (For the DNS function, use Configuration Tool ver 3.2.0 or above)
- ◆ Hyper terminal

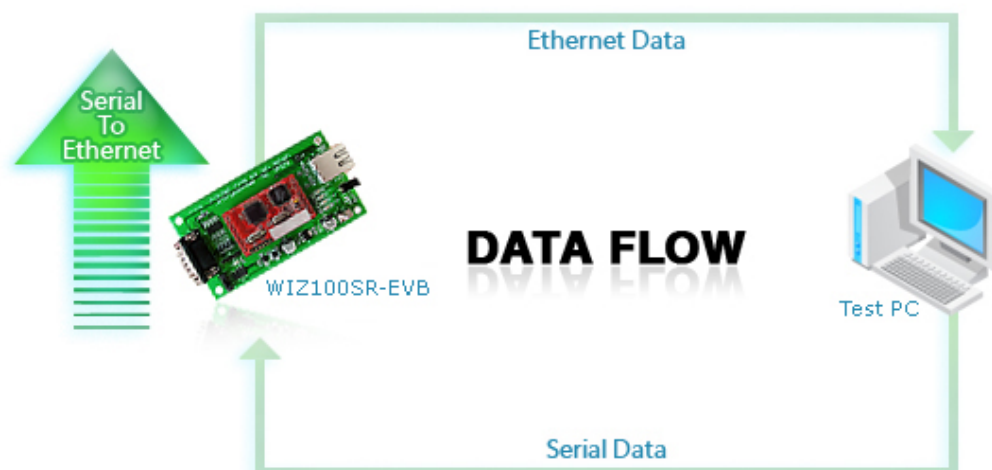

Fig 16 Data Flow (Serial -> Ethernet)

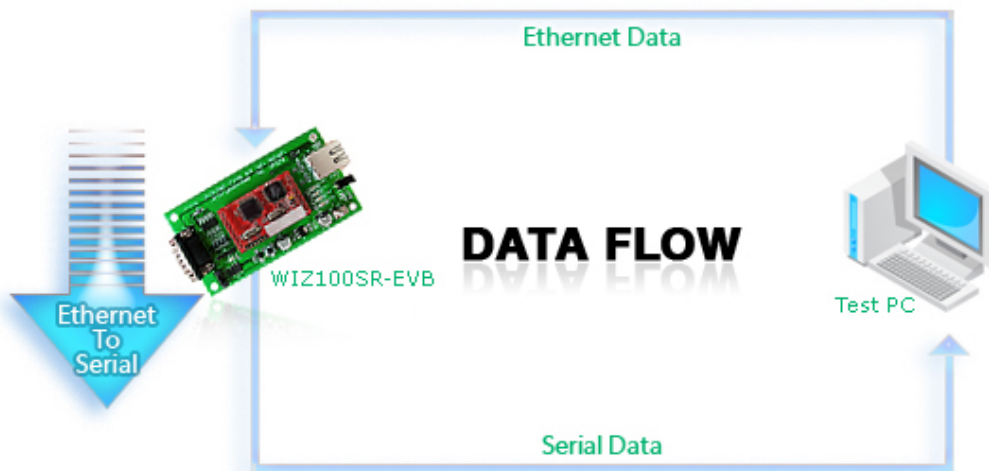

Fig 17 Data Flow (Ethernet -> Serial)

STEP1.

- ① Make sure the position of the mode switch is normal mode. (If JP4 of the test board is configured as Config mode, the network function is disabled, and the Configuration Tool can not be used.)
- ② Connect the computer and WIZ100SR Test Board by using RS-232.
- ③ Connect the computer and WIZ100SR Test Board by Ethernet cable (Direct or Crossover Cable).
- ④ Power on the WIZ100SR Test Board.

STEP2. (WIZ100SR Environment Setup)

- ① Modules are searched by click search button of the Configuration Tool.
- ② Select the board to be configured and change the value. To apply the changed value, click Setting button.
- ③ If changed value is successfully applied, the "Complete setting" message is displayed as shown in Fig 18

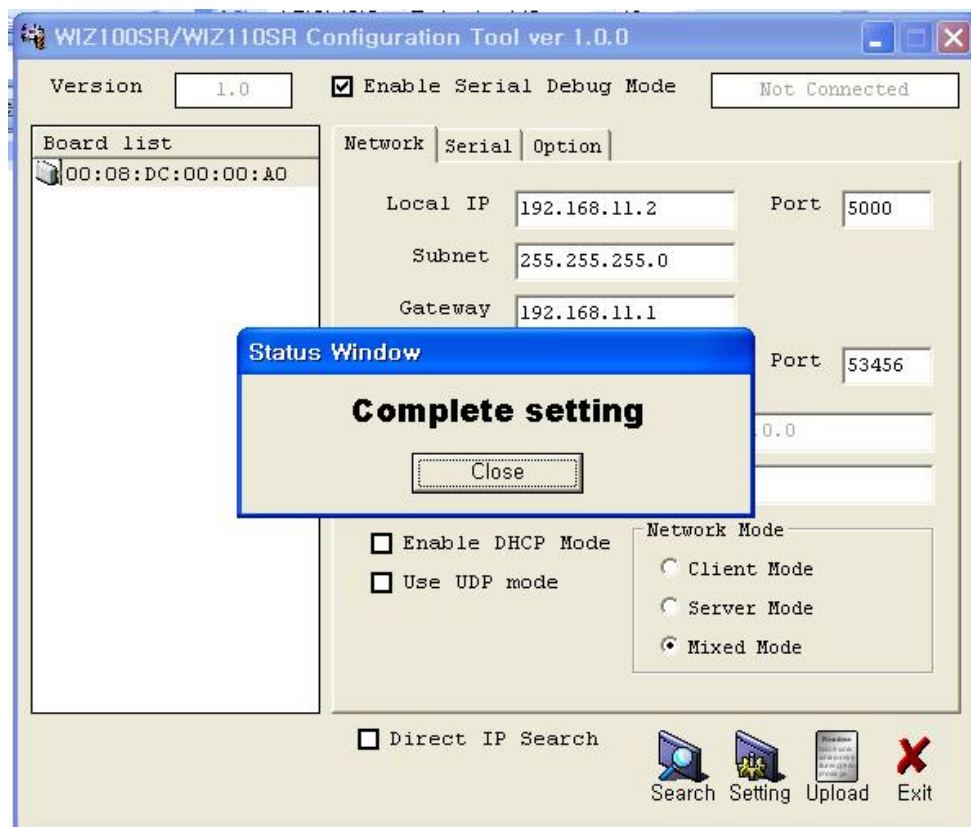

Fig 18 Result Window after Running "Setting"

STEP3. (Data Transmission)

- ① Run terminal emulator program (e.g. Hyper terminal) on Test PC.
- ② Set the baud rate as the same value of WIZ100SR

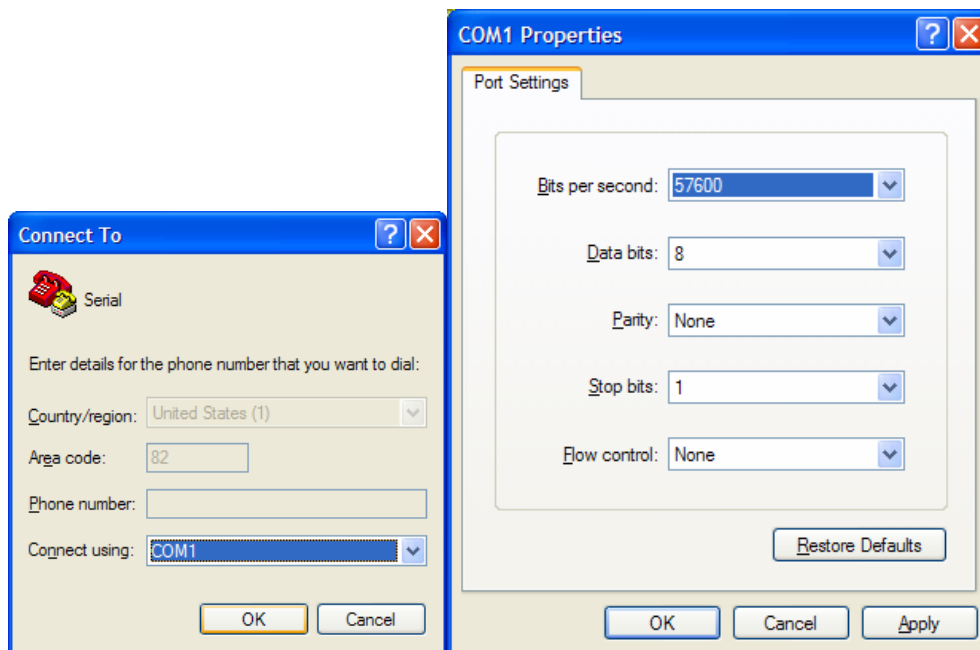

Fig 19 Serial Terminal Program Configuration

- ③ Execute another Hyper terminal and set the IP address and port number.

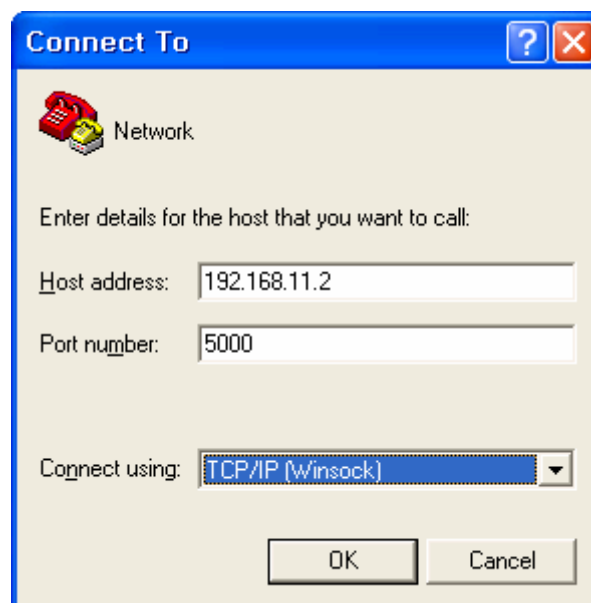

Fig 20 Network Terminal Program Configuration

- ④ Type some character on the serial Hyper terminal screen. In this example, "01234567890" is entered.
- ⑤ Make sure this data is shown on the Network Hyper terminal window. (Serial to Ethernet)

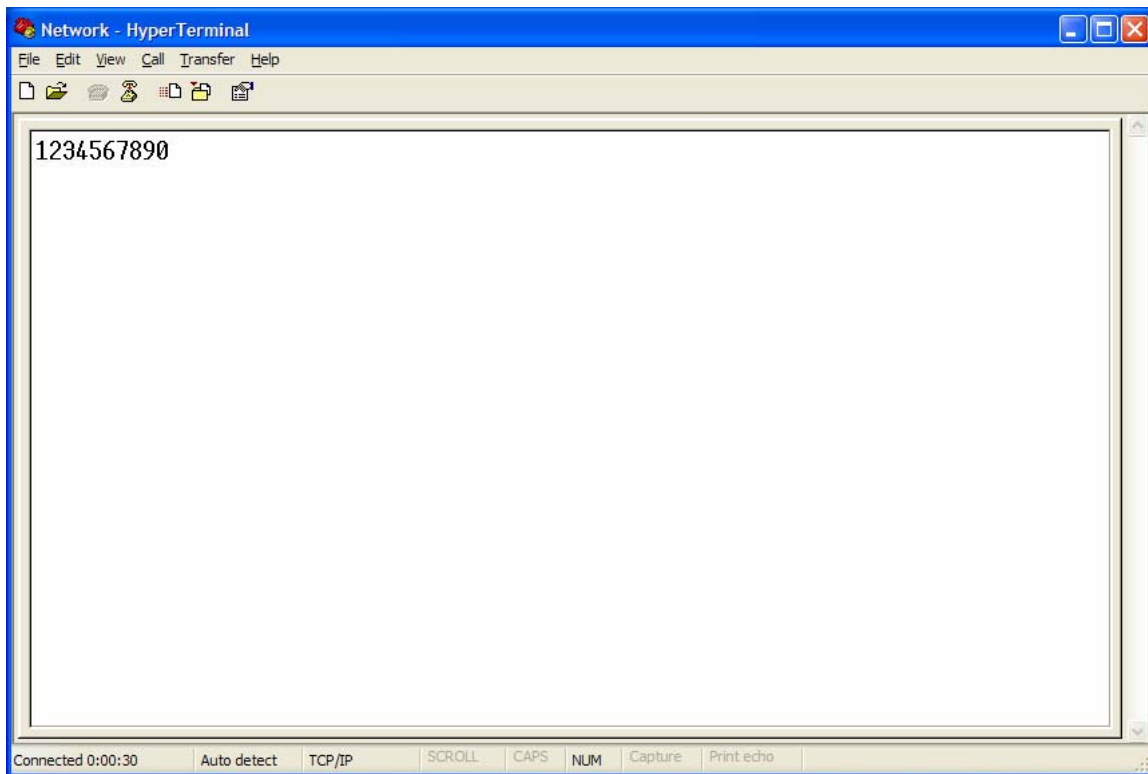

Fig 21 Received Data by Network Terminal Program

- ⑥ As the same way, type some characters on the network Hyper terminal, and then make sure these data are shown in the serial Hyper terminal window. (Ethernet to Serial)

* Above test can be performed more easily and conveniently by using Device Terminal program. Below is the screen of the Device Terminal program.

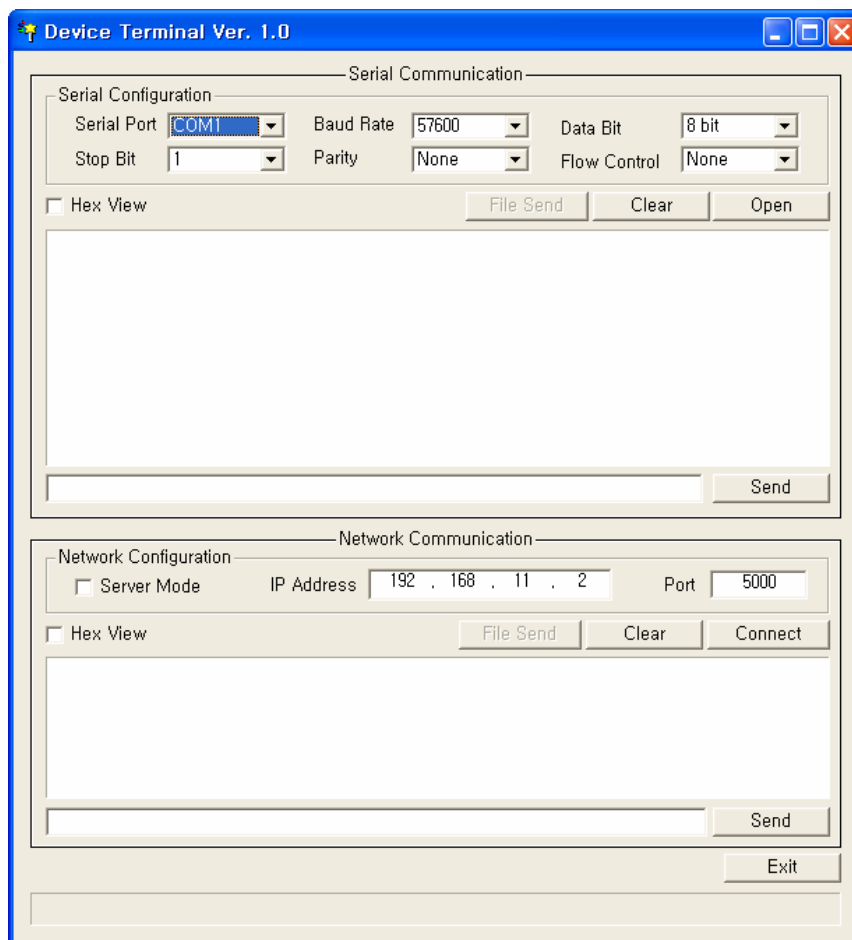

Fig 22 Device Terminal Program

Device Terminal is the program into which serial and network terminals integrated for more efficient testing of WIZnet gateway modules.

As shown in Fig 22, at the upper part of the program, you configure serial setting of WIZ100SR. By click "Open" button, serial communication is available.

At the Network Terminal, the lower part of the program, it is possible to test both of TCP Client and TCP Server modes. If Server Mode is checked, Device Terminal will operate as server mode, and the WIZ100SR module will work as client mode. The PC where the Device Terminal is operating will work as a server, the IP address of the PC should be set as Server IP of the module. If Server mode is not checked, Device Terminal will operate as client mode, and the module as server. For the IP address and port, input IP address and port number of WIZ100SR and click "Connect" button for network communication.

When serial and network terminals are connected, input any charater at the Data Input window and click "Send" button. You can check the data transferred to another window.

