

High Efficacy UV LED Emitter **LZ4-00UA00**

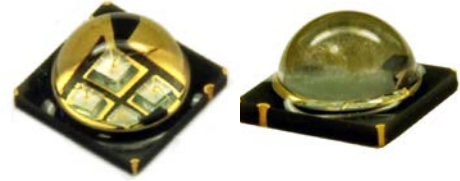

Key Features

- High Efficacy 10W UV LED
- Ultra-small foot print – 7.0mm x 7.0mm x 4.3mm
- Surface mount ceramic package with integrated glass lens
- Very low Thermal Resistance (1.1°C/W)
- Individually addressable die
- Very high Radiant Flux density
- JEDEC Level 2 for Moisture Sensitivity Level
- Autoclave complaint (JEDEC JESD22-A102-C)
- Lead (Pb) free and RoHS compliant
- Reflow solderable (up to 6 cycles)
- Emitter available on [Standard](#) or Serially [Connected](#) MCPCB (optional)

Typical Applications

- Dental Curing and Teeth Whitening
- Sterilization and Medical
- DNA Gel

Description

The LZ4-00UA00 UV LED emitter provides superior radiometric power in the wavelength range specifically required for sterilization, dental curing lights, and numerous medical applications. With a 7.0mm x 7.0mm x 4.3mm ultra-small footprint, this package provides exceptional optical power density. The radiometric power performance and optimal peak wavelength of this LED are matched to the response curves of many dental resins, resulting in a significantly reduced curing time. The patent-pending design has unparalleled thermal and optical performance. The high quality materials used in the package are chosen to optimize light output, have excellent UV resistance, and minimize stresses which results in monumental reliability and radiant flux maintenance.

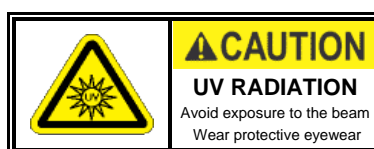

Table of Contents

Product Nomenclature	3
IPC/JEDEC Moisture Sensitivity	3
Average Radiant Flux Maintenance Projections	3
Radiant Flux Binning	4
Peak Wavelength Binning	4
Forward Voltage Binning	4
Absolute Maximum Ratings	5
Optical Characteristics	5
Electrical Characteristics	5
Mechanical Dimensions	6
Pin-Out	6
Recommended Solder Pad Layout	6
Reflow Soldering Profile	7
Typical Radiation Pattern	7
Typical Relative Spectral Power Distribution	8
Typical Peak Wavelength Shift over Temperature.	8
Typical Normalized Radiant Flux	9
Typical Normalized Radiant Flux over Temperature	9
Typical Forward Current Characteristics	10
Current Derating Curves	10
Emitter Tape & Reel Specifications	11
Company Information	12

Product Nomenclature

The LZ Series part number designation is defined as follows:

L Z A – B C D E F G

Where:

A – designates the number of LED die in the package (“4” for 10W)

B – designates the package level (“0” for Emitter, 4 for emitter on a 1-channel star MCPCB, 2 for emitter on a 4-channel star MCPCB.)

C – designates the radiation pattern pattern (“0” for Lambertian)

D and E – designate the color (“UA” - Typical UV Peak Wavelength = 400nm)

F and G – designate “00”

Ordering information:

For ordering LedEngin products, please reference the base part number. The base part number represents any of the radiant flux, peak wavelength, or forward voltage bins specified in the binning tables below. For ordering products with special bin selections, please contact a LedEngin sales representative or authorized distributor.

IPC/JEDEC Moisture Sensitivity Level

Table 1 - IPC/JEDEC J-STD MSL-20 Classification:

Level	Soak Requirements					
	Floor Life		Standard		Accelerated	
	Time	Conditions	Time (hrs)	Conditions	Time (hrs)	Conditions
2	1 Year	≤ 30°C/ 60% RH	168 +5/-0	85°C/ 60% RH	n/a	n/a

Notes for Table 1:

- The standard soak time is the sum of the default value of 24 hours for the semiconductor manufacturer’s exposure time (MET) between bake and bag and the floor life of maximum time allowed out of the bag at the end user of distributor’s facility.

Average Radiant Flux Maintenance Projections

Based on long-term WHTOL testing, LedEngin projects that the LZ Series will deliver, on average, 90% Radiant Flux Maintenance at 100,000 hours of operation at a forward current of 700 mA. This projection is based on constant current operation with junction temperature maintained at or below 115°C.

Radiant Flux Bins

Table 2:

Bin Code	Minimum Radiant Flux (Φ) @ $I_F = 700\text{mA}$ ^[1,2] (W)	Maximum Radiant Flux (Φ) @ $I_F = 700\text{mA}$ ^[1,2] (W)	Typical Radiant Flux (Φ) @ $I_F = 1000\text{mA}$ ^[2] (W)
N	1.2	1.6	1.9
P	1.6	2.0	2.3
Q	2.0	2.4	2.8
R	2.4	3.0	3.4

Notes for Table 2:

1. Radiant flux performance guaranteed within published operating conditions. LedEngin maintains a tolerance of $\pm 10\%$ on flux measurements.
2. Future products will have even higher levels of radiant flux performance. Contact LedEngin Sales for updated information.

Peak Wavelength Bins

Table 3:

Bin Code	Minimum Peak Wavelength (λ_P) @ $I_F = 700\text{mA}$ ^[1] (nm)	Maximum Peak Wavelength (λ_P) @ $I_F = 700\text{mA}$ ^[1] (nm)
U5	390	395
U6	395	400
U7	400	405
U8	405	410

Notes for Table 3:

1. LedEngin maintains a tolerance of $\pm 2.0\text{nm}$ on peak wavelength measurements.

Forward Voltage Bins

Table 4:

Bin Code	Minimum Forward Voltage (V_F) @ $I_F = 700\text{mA}$ ^[1,2] (V)	Maximum Forward Voltage (V_F) @ $I_F = 700\text{mA}$ ^[1,2] (V)
0	13.76	18.56

Notes for Table 4:

1. LedEngin maintains a tolerance of $\pm 0.16\text{V}$ for forward voltage measurements.
2. Forward Voltage is binned with all four LED dice connected in series.

Absolute Maximum Ratings

Table 5:

Parameter	Symbol	Value	Unit
DC Forward Current ^[1]	I_F	1000	mA
Peak Pulsed Forward Current ^[2]	I_{FP}	1000	mA
Reverse Voltage	V_R	See Note 3	V
Storage Temperature	T_{stg}	-40 ~ +150	°C
Junction Temperature	T_J	125	°C
Soldering Temperature ^[4]	T_{sol}	180	°C
Allowable Reflow Cycles		6	
Autoclave Conditions ^[5]		121°C at 2 ATM, 100% RH for 168 hours	
ESD Sensitivity ^[6]		> 1,000 V HBM Class 1C JESD22-A114-D	

Notes for Table 5:

- Maximum DC forward current is determined by the overall thermal resistance and ambient temperature. Follow the curves in Figure 10 for current derating.
- Pulse forward current conditions: Pulse Width \leq 10msec and Duty Cycle \leq 10%.
- LEDs are not designed to be reverse biased.
- Use low temperature solders. LedEngin recommends 58Bi-42Sn (wt.%) Solder. See Reflow Soldering Profile Figure 3.
- Autoclave Conditions per JEDEC JESD22-A102-C.
- LedEngin recommends taking reasonable precautions towards possible ESD damages and handling the LZ4-00UA00 in an electrostatic protected area (EPA). An EPA may be adequately protected by ESD controls as outlined in ANSI/ESD S6.1.

Optical Characteristics @ $T_C = 25^\circ\text{C}$

Table 6:

Parameter	Symbol	Typical	Unit
Radiant Flux (@ $I_F = 700\text{mA}$)	Φ	2.1	W
Radiant Flux (@ $I_F = 1000\text{mA}$)	Φ	2.7	W
Peak Wavelength ^[1]	λ_P	400	nm
Viewing Angle ^[2]	$2\Theta_{\frac{1}{2}}$	115	Degrees
Total Included Angle ^[3]	$\Theta_{0.9}$	175	Degrees

Notes for Table 6:

- When operating the UV LED, observe IEC 60825-1 class 3B rating. Avoid exposure to the beam.
- Viewing Angle is the off axis angle from emitter centerline where the radiant power is $\frac{1}{2}$ of the peak value.
- Total Included Angle is the total angle that includes 90% of the total radiant flux.

Electrical Characteristics @ $T_C = 25^\circ\text{C}$

Table 6:

Parameter	Symbol	Typical		Unit
		1 Die	4 Dice	
Forward Voltage (@ $I_F = 700\text{mA}$)	V_F	3.9	15.6	V
Forward Voltage (@ $I_F = 1000\text{mA}$)	V_F	4.1	16.5	V
Temperature Coefficient of Forward Voltage	$\Delta V_F / \Delta T_J$	-14.2		mV/°C
Thermal Resistance (Junction to Case)	$R\Theta_{J-C}$	1.1		°C/W

Mechanical Dimensions (mm)

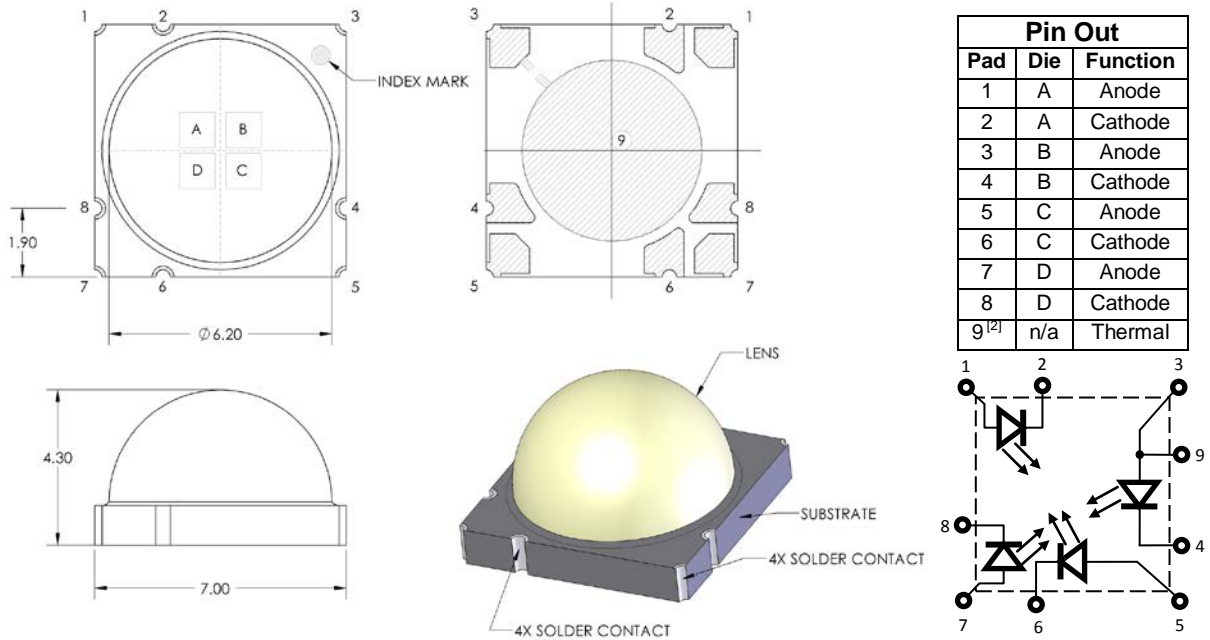

Figure 1: Package outline drawing.

Notes for Figure 1:

1. Unless otherwise noted, the tolerance = ± 0.20 mm.
2. Thermal contact, Pad 9, is electrically connected to Pad 3. Do not connect any pad to the thermal contact, Pad 9. When mounting the LZ4-00UA00 onto a MCPCB, by default its dielectric layer provides for the necessary electrical insulation in between all contact pads. LedEngin offers [LZ4-20UA00](#) and [LZ4-40UA00](#) MCPCB options which provide for electrical insulation between all contact pads. Please refer to Application Note MCPCB Option 2 and Option 4, or contact a LedEngin sales representative for more information.

Recommended Solder Pad Layout (mm)

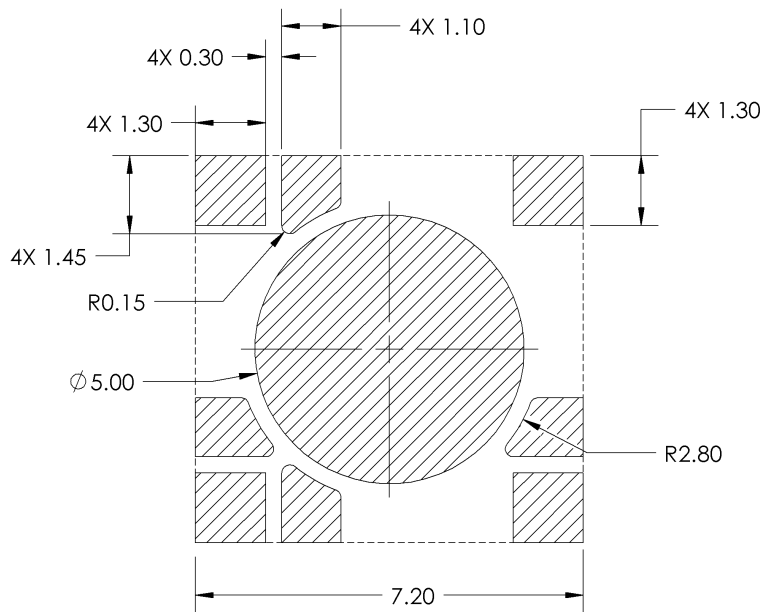

Figure 2: Recommended solder mask opening (hatched area) for anode, cathode, and thermal pad.

Note for Figure 2:

1. Unless otherwise noted, the tolerance = ± 0.20 mm.

Reflow Soldering Profile

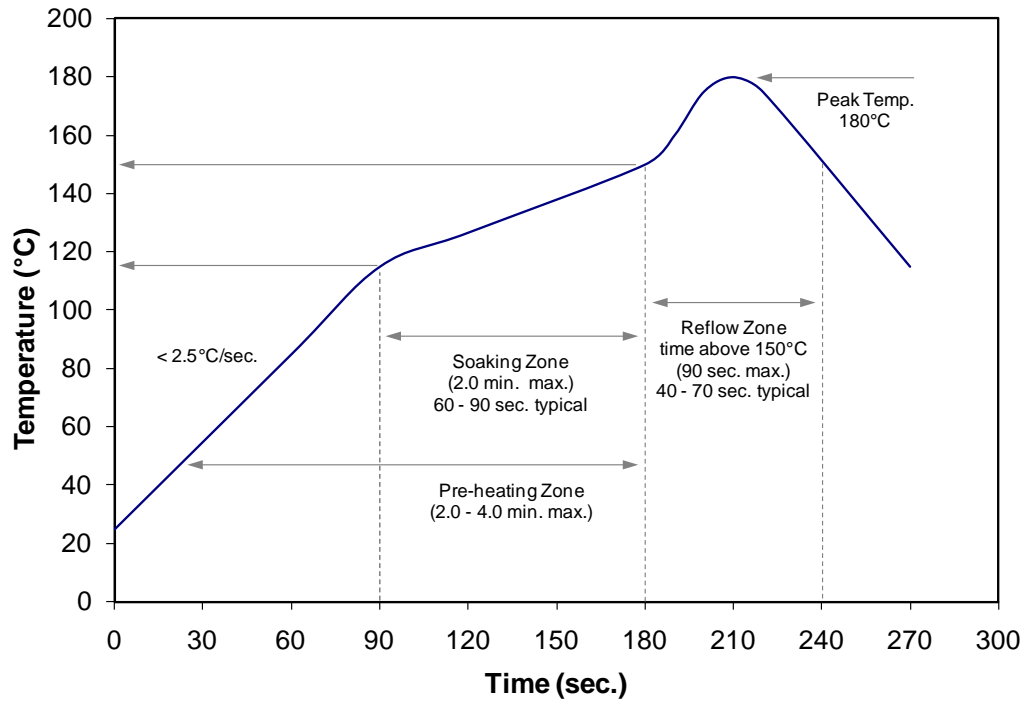

Figure 3: Reflow soldering profile for lead free soldering.

Notes for Figure 3:

1. Solder profile for low temperature solder. LedEngin recommends 58Bi-42Sn (wt.%) Solder for the LZ4-00UA00.

Typical Radiation Pattern

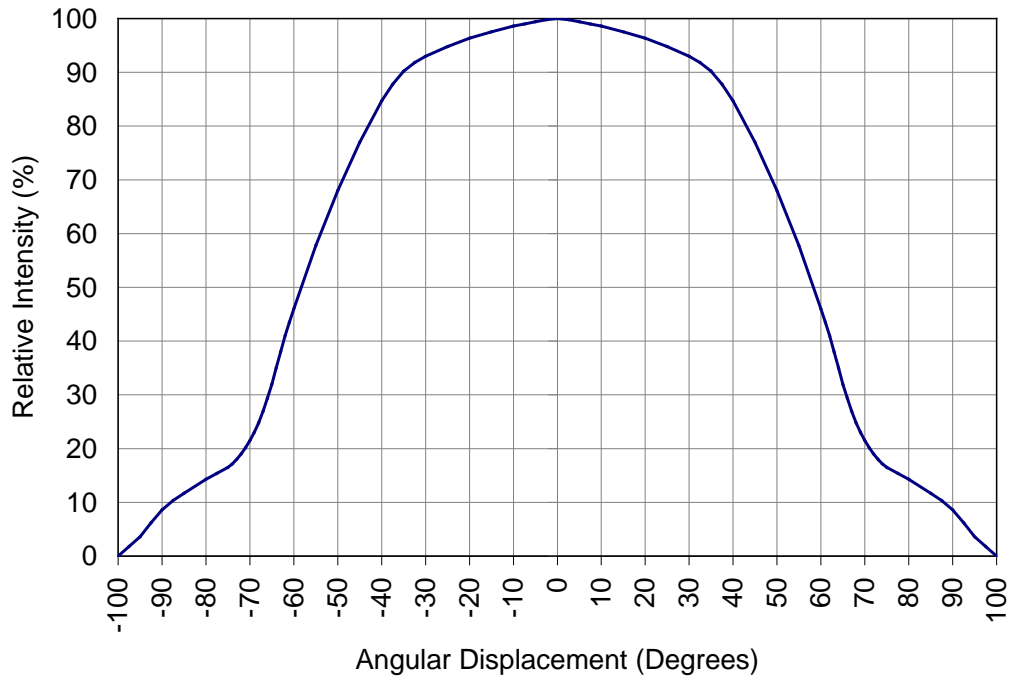

Figure 4: Typical representative spatial radiation pattern.

Typical Relative Spectral Power Distribution

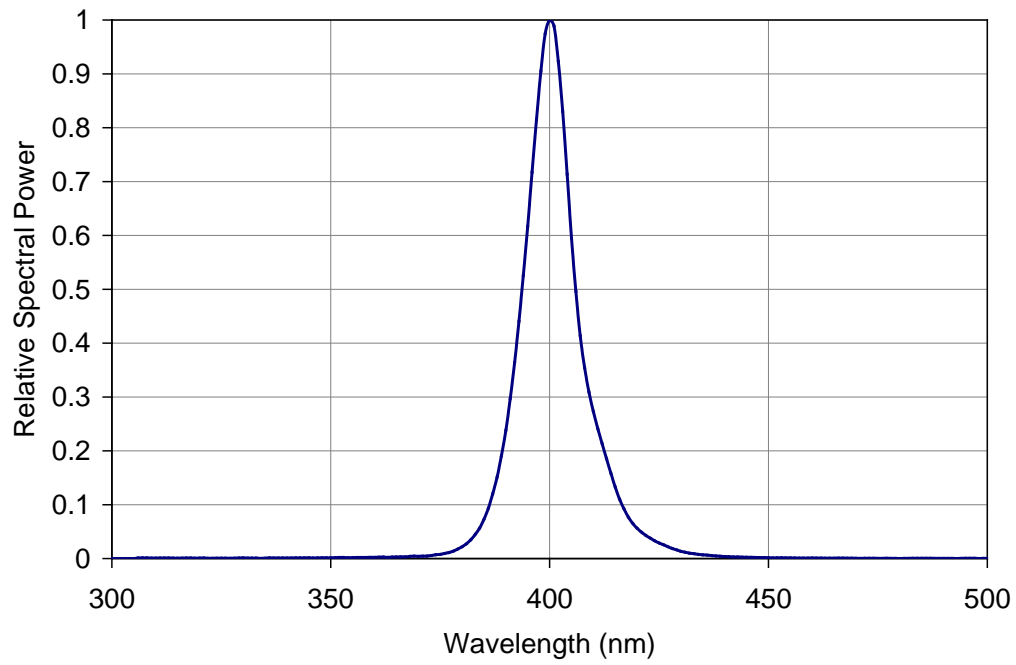

Figure 5: Typical relative spectral power vs. wavelength @ $T_C = 25^\circ\text{C}$.

Typical Peak Wavelength Shift over Temperature

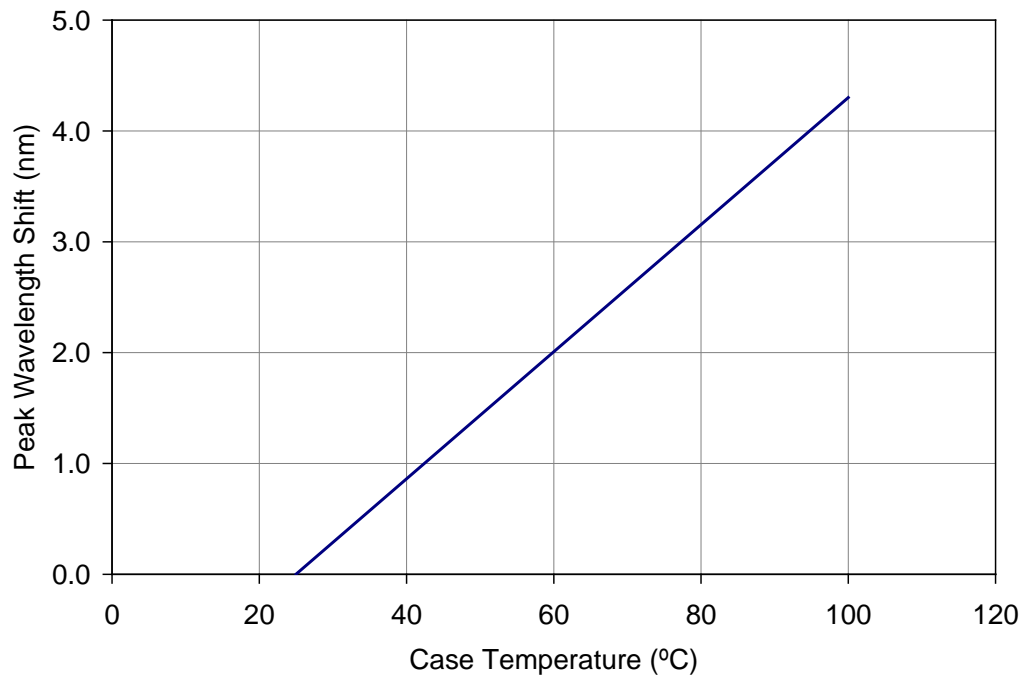

Figure 6: Typical peak wavelength shift vs. case temperature.

Typical Normalized Radiant Flux

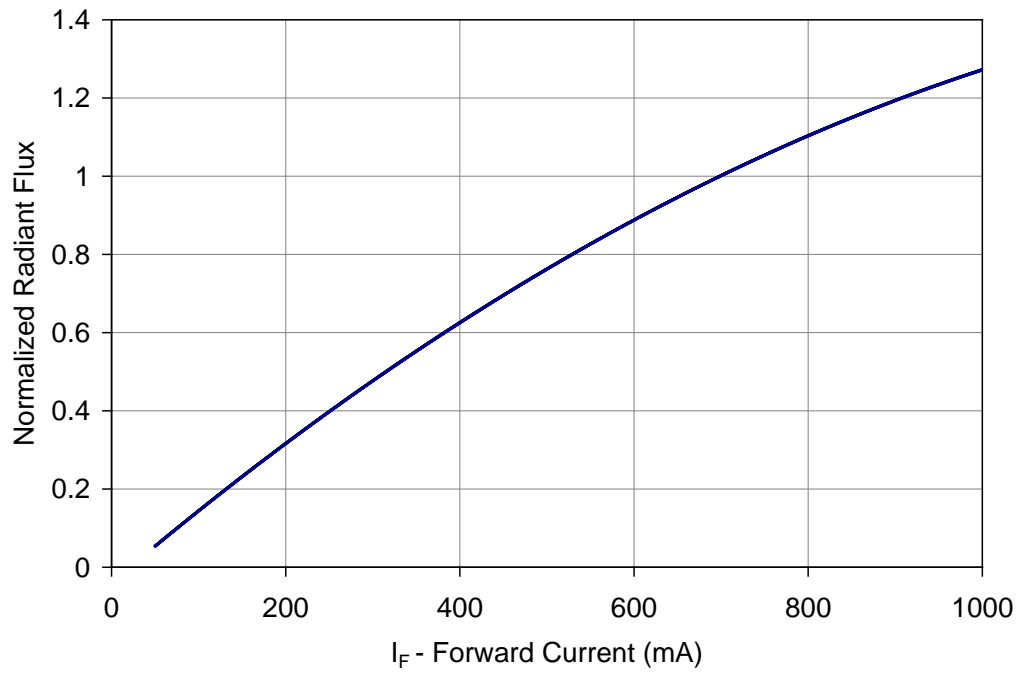

Figure 7: Typical normalized radiant flux vs. forward current @ $T_C = 25^\circ\text{C}$.

Typical Normalized Radiant Flux over Temperature

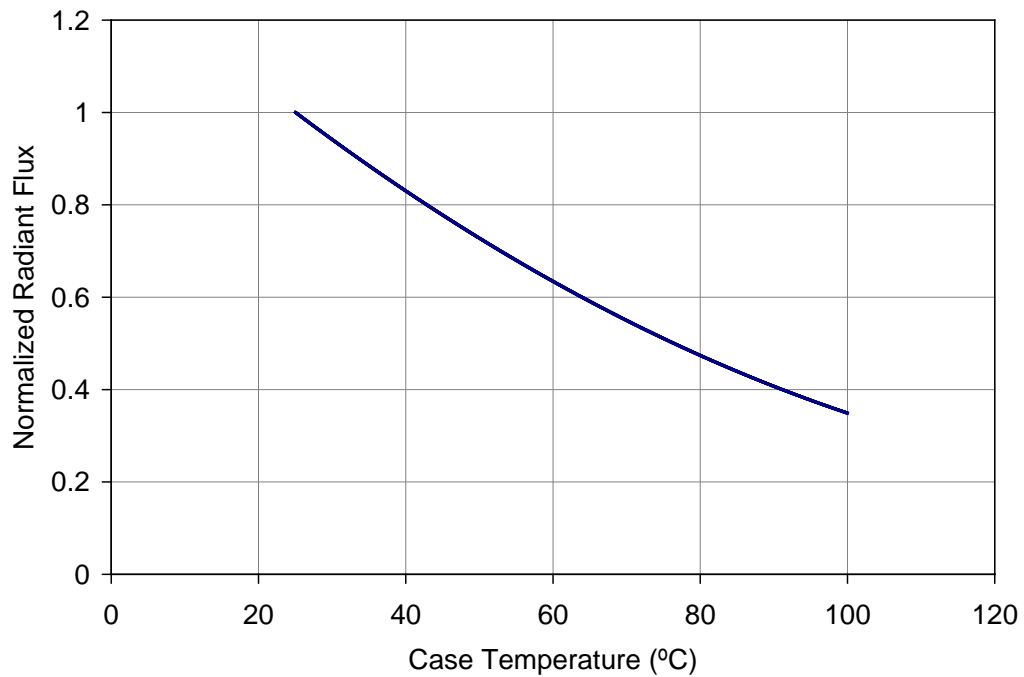

Figure 8: Typical normalized radiant flux vs. case temperature.

Typical Forward Current Characteristics

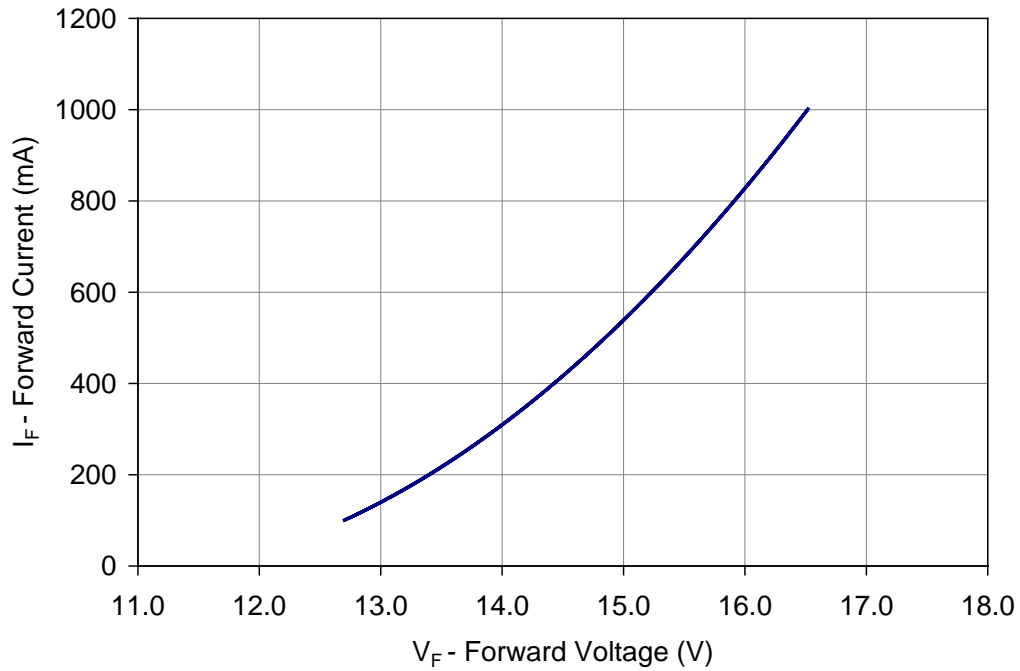

Figure 9: Typical forward current vs. forward voltage @ $T_C =$ at 25°C.

Current Derating

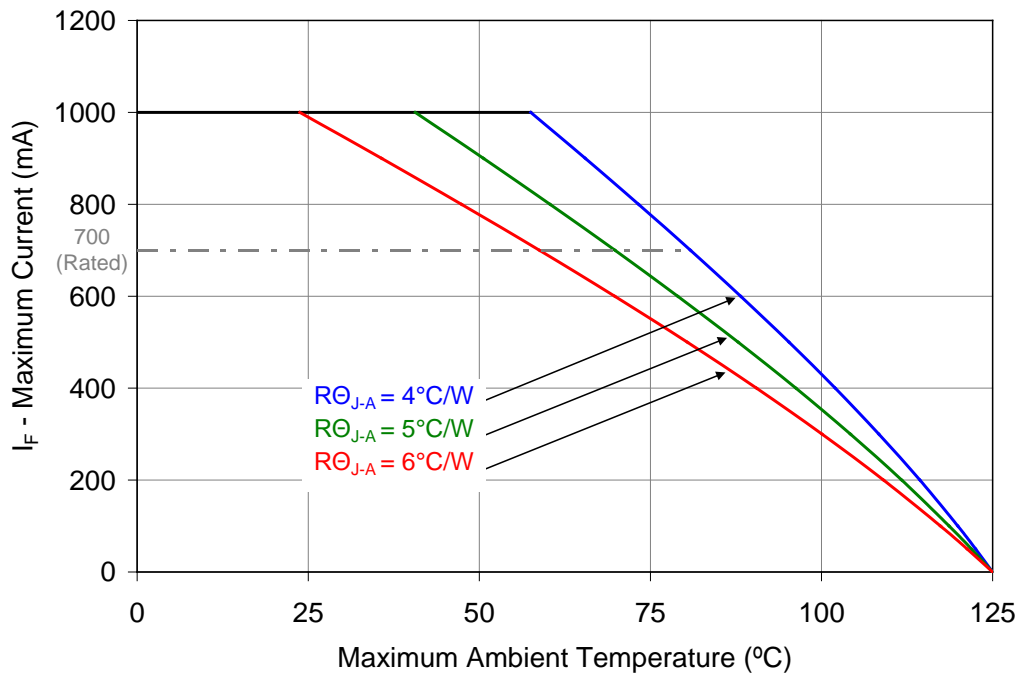

Figure 10: Maximum forward current vs. ambient temperature based on $T_{J(\text{MAX})} = 125^\circ\text{C}$.

Notes for Figure 10:

1. $R\theta_{J-C}$ [Junction to Case Thermal Resistance] for the LZ4-00UA00 is typically 1.1°C/W.
2. $R\theta_{J-A}$ [Junction to Ambient Thermal Resistance] = $R\theta_{J-C} + R\theta_{C-A}$ [Case to Ambient Thermal Resistance].

Emitter Tape and Reel Specifications (mm)

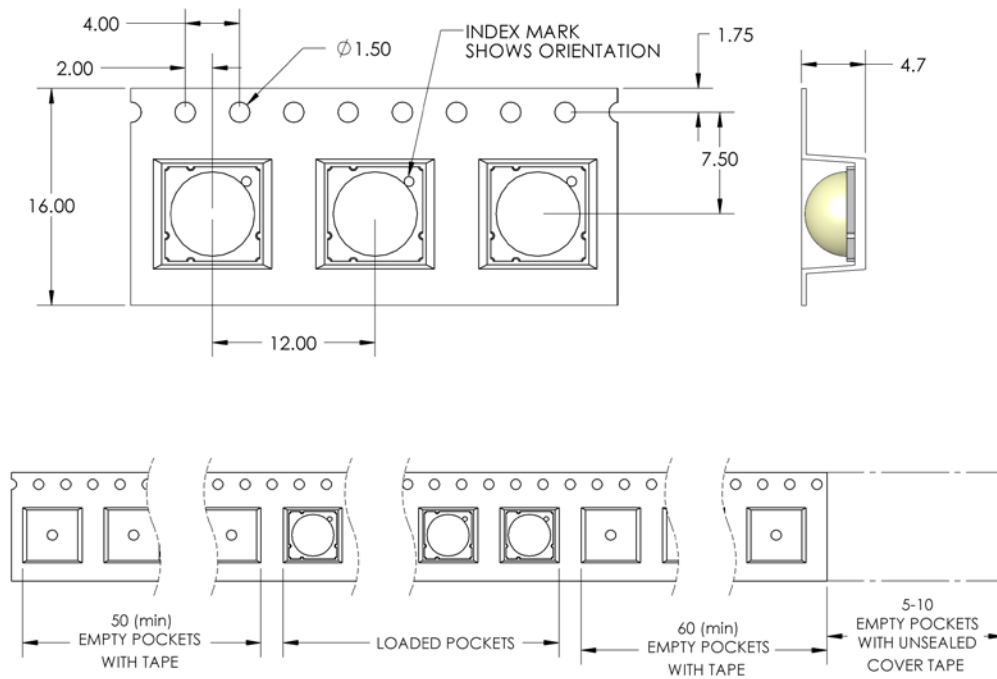

Figure 11: Emitter carrier tape specifications (mm).

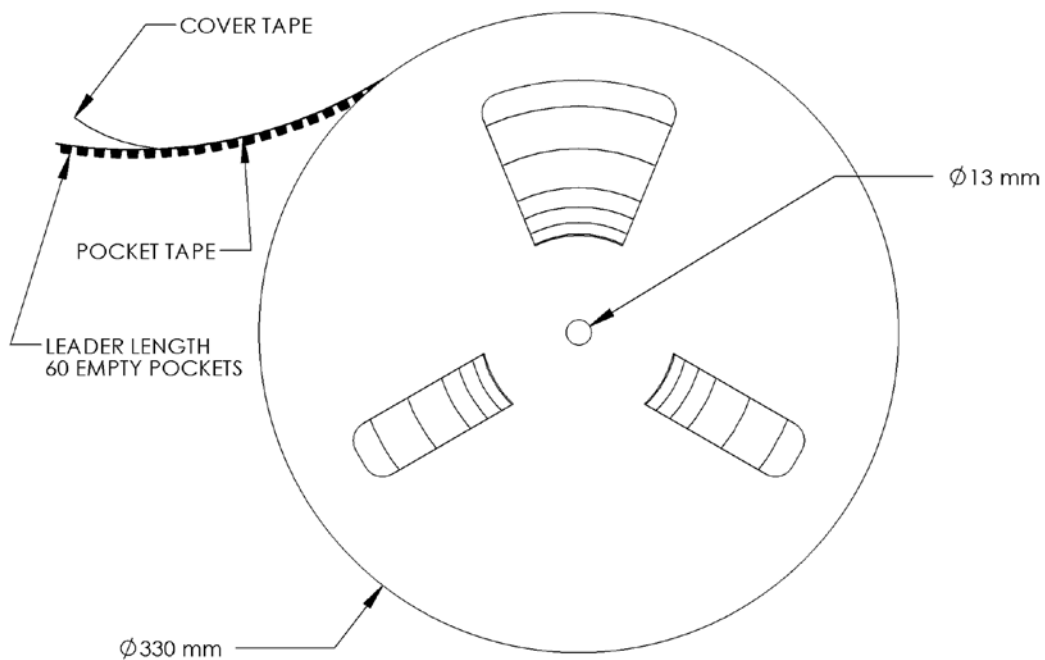

Figure 12: Emitter Reel specifications (mm).

Notes:

1. Packaging contains UV caution labels. Avoid exposure to the beam and wear appropriate protective eyewear when operating the UV LED.

Company Information

LedEngin, Inc. is a Silicon Valley based solid-state lighting company specializing in the development and manufacturing of unprecedented high-power LED emitters, modules and replacement lamps. LedEngin's packaging technologies lead the industry with products that feature lowest thermal resistance, highest flux density and consummate reliability, enabling compact and efficient solid state lighting solutions.

LedEngin's LED emitters range from 5W to 90W with ultra-compact footprints and are available in single color products including Cool White, Neutral White, Warm White, Red, Green, Blue, Amber, Deep Red, Far Red, Dental Blue and UV as well as multi-color products with RGB, RGBA and RGBW options. LedEngin's brightest White LEDs are capable of emitting 5,500 lumens.

LedEngin's robust emitters are at the core of its unique line of modules and replacement lamps producing unmatched beam quality resulting in true Lux on Target™ for a wide variety of spot and narrow flood directional lighting applications.

LedEngin is committed to providing products that conserve natural resources and reduce greenhouse emissions.

LedEngin reserves the right to make changes to improve performance without notice.

Please contact Sales@ledengin.com or (408) 492-0620 for more information.