

# **EBLOCKS<sup>®</sup>**

RFID board

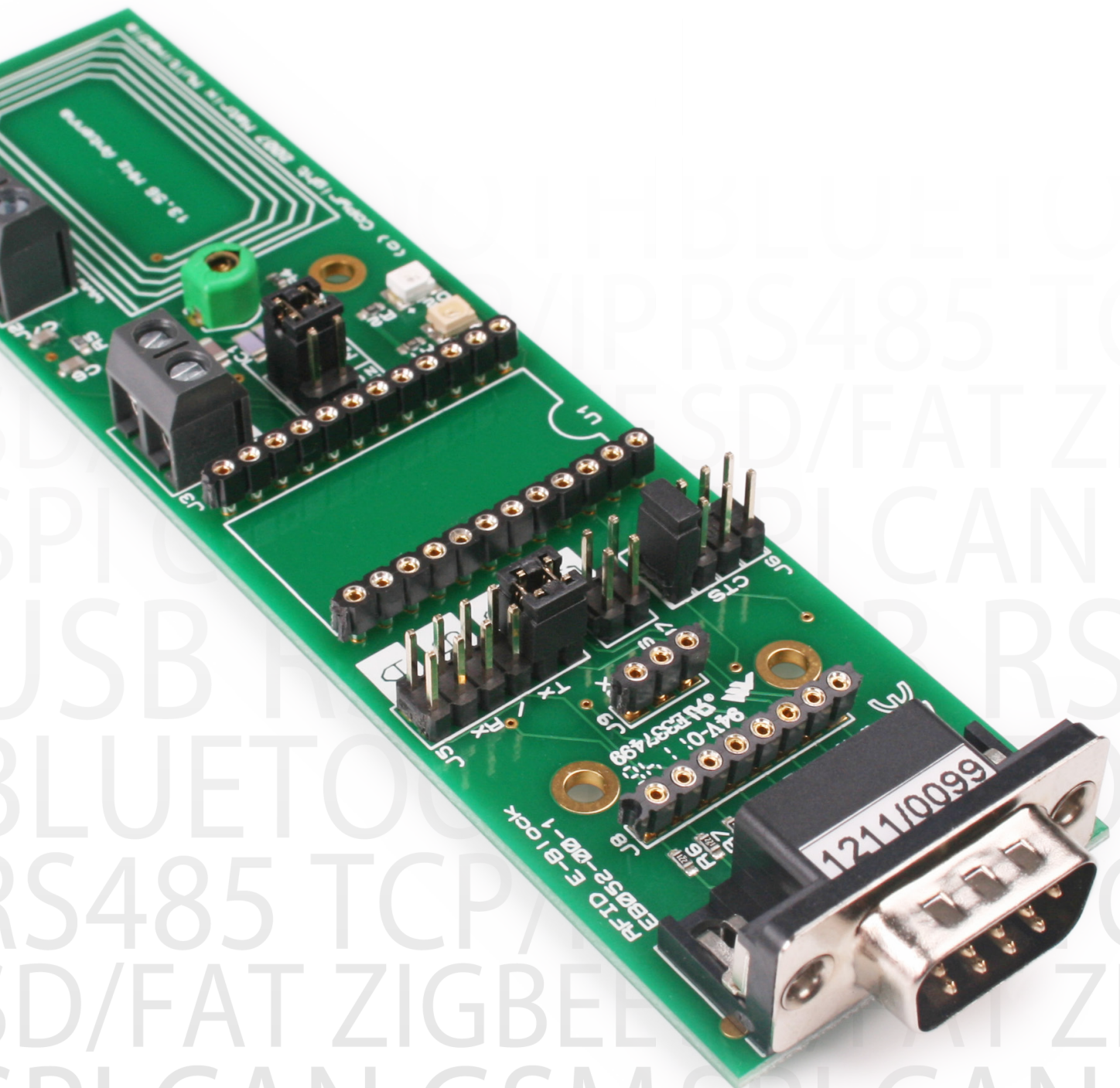

# Contents

About this document	3
Board layout	3
General information	4
Circuit description	6
Protective cover	6
Circuit diagram	7

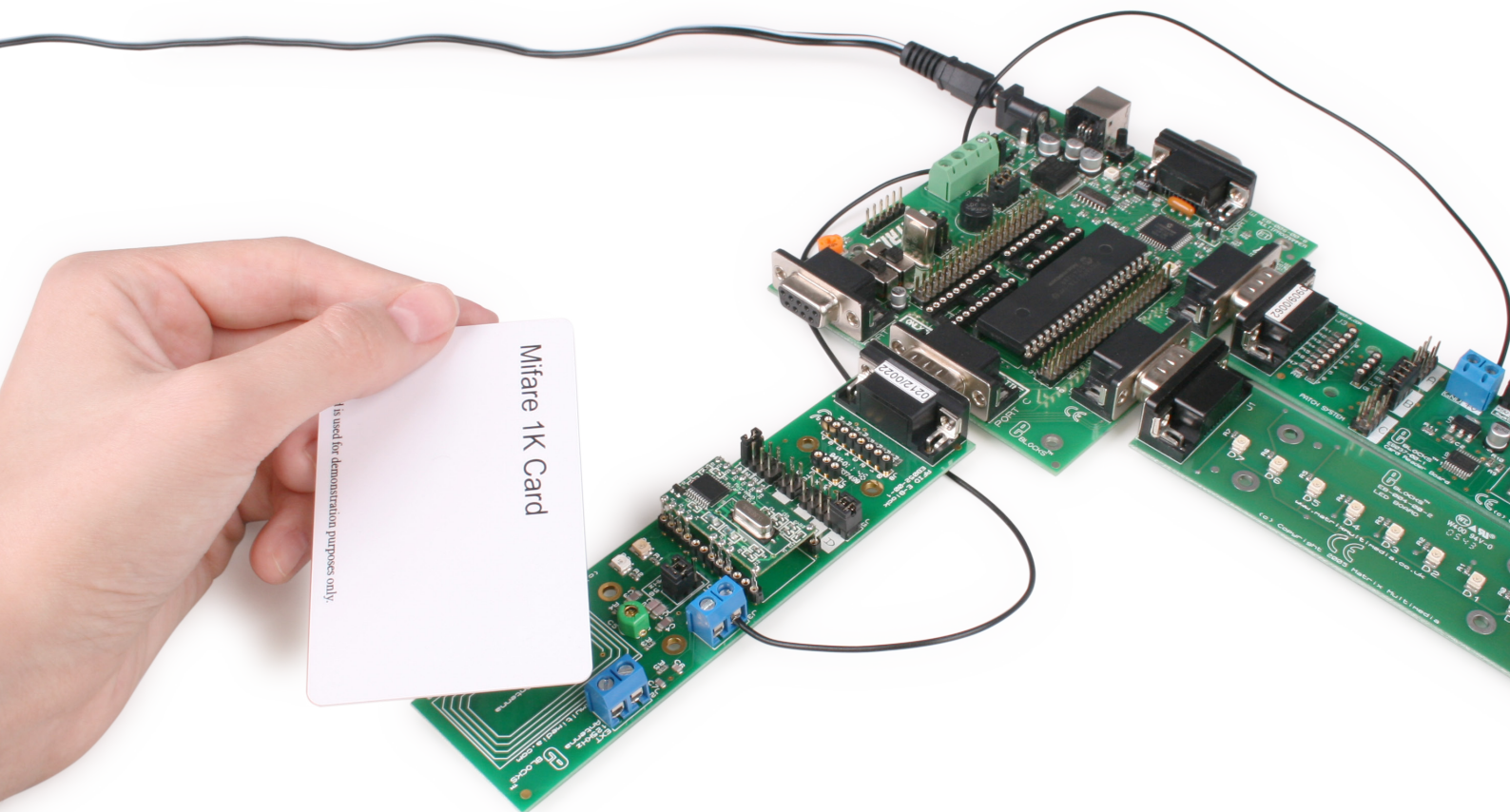

# About this document

This document concerns the EB052 E-blocks RFID board.

## 1. Trademarks and copyright

PIC and PICmicro are registered trademarks of Arizona Microchip Inc. E-blocks is a trademark of Matrix Technology Solutions Ltd.

## 2. Disclaimer

The information provided within this document is correct at the time of going to press. Matrix TSL reserves the right to change specifications from time to time.

## 3. Testing this product

It is advisable to test the product upon receiving it to ensure it works correctly. Matrix provides test procedures

for all E-blocks, which can be found in the Support section of the website.

## 4. Product support

If you require support for this product then please visit the Matrix website, which contains many learning resources for the E-blocks series. On our website you will find:

- How to get started with E-blocks - if you are new to E-blocks and wish to learn how to use them from the beginning there are resources available to help.
- Relevant software and hardware that allow you to use your E-blocks product better.
- Example files and programs.
- Ways to get technical support for your product, either via the forums or by contacting us directly.

# Board layout

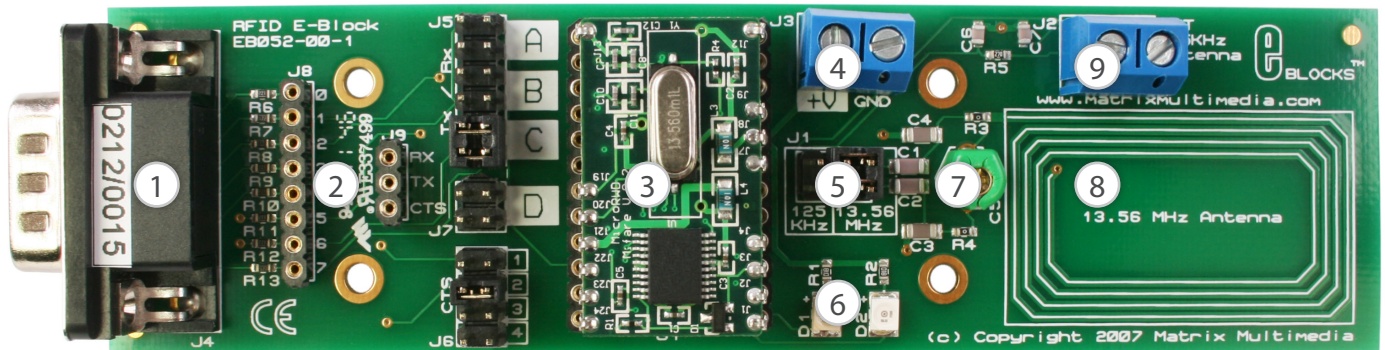

1. 9-way downstream D-type connector

2. Patch system

3. RFID module

4. Power terminals

5. Frequency / antenna select

6. Status LEDs

1. Red LED flashing - antenna needs tuning

2. Red LED stable - antenna tuned correctly

3. Green LED stable - RFID device detected and connected

7. Sensitivity tuning capacitor

8. Onboard 13.56MHz antenna

9. External 125KHz antenna connector (not fitted as standard)

# General information

The EB052 RFID E-block provides a RFID interface that can communicate with all common RFID devices running at either 125KHz or 13.56MHz. RFID stands for Radio Frequency Identifier. RFID is a means of tagging items such as stock items. A good example of this is the use of RFID in stores to detect theft. The RFID E-block interfaces RFID devices, also known as 'tags', through a high frequency radio wave. This radio frequency burst acts as a dual function: to simultaneously provide power to the RFID device, and to communicate with the device. RFID devices or tags can have internal peripherals such as EEPROM, Flash and can even encrypt data to industrial standards.

## 1. Features

- RFID wireless communications
- Flowcode macros available
- 125KHz or 13.56MHz operating frequency (125KHz RFID module and antenna available separately)
- Onboard 12.56MHz PCB antenna
- Status LEDs
- Tuning capacitors
- Range of approx. 10cm

## 2. RFID compatibility

See tables below.

13.56MHz RWD-ICODE RFID module (module supplied as standard)

Transponder type	Memory size (total/user)	Baud rate	Security	Key feautes
MIFARE 1K	1024 / 768	Up to 106K	Yes	R/W secure, card, payment, access
MIFARE 4K	4096 / 3456	Up to 106K	Yes	R/W secure, card, payment, access
Ultralight	64 / 48	Up to 106K	No	R/W low cost, payment
ICODE SLI	128 / 112	Up to 53K	No	R/W low cost, asset tracking, smart labels

125KHz RWD-QT (module sold separately)

Transponder type	Memory size (total/user)	Baud rate	Security	Key feautes
HITAG 1	256 / 192	Up to 4K	Yes	R/W general purpose
HITAG S256/2048	256 / 256	Up to 4K	Yes	R/W general purpose
HITAG 2	32 / 16	Up to 4K	Yes	R/W secure access, asset tracking
EM4001/4102	8 / 5	Up to 4K	No	R access control
MCRF200/123	16 / 14	Up to 4K	No	R access control

**Note:** to use the 125KHz RFID devices you must order a separate 125KHz RFID module and external antenna.

## 3. 3.3V system compatibility

The RFID board requires a 5V supply.

## 4. Communications

The RFID modules are configured by means of using a TTL level RS232 bus. This protocol requires a start bit, eight data bits and a stop bit.

The baud rate for the modules is set to 9600, with no parity, and there is also a flow control, CTS, line that can

be used.

On the next page is a functional diagram of the timing required by the RFID modules. The module is ready to receive data when the CTS line drops to logic zero. After sending the data you have to then wait at least 100ms before data will be transmitted back from the module.



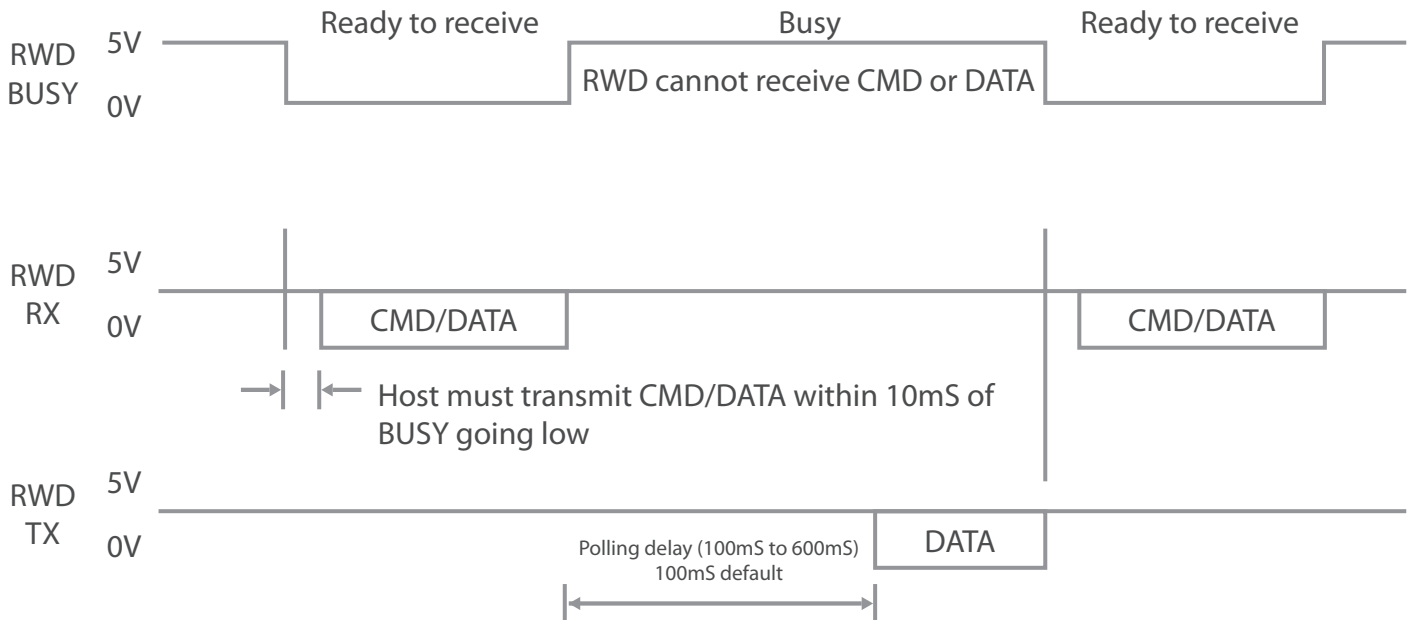

## 5. Device command overview

12.56MHz RWD-ICODE RFID module (module supplied as standard)

Command	Command data	Data 1	Data 2	Data 3	Data 4	Data 5	Data 6	Data 7	Acknowledge
Card / label status	0x53	N/A	N/A	N/A	N/A	N/A	N/A	N/A	1FFFFFFX
Message report	0x7A	N/A	N/A	N/A	N/A	N/A	N/A	N/A	Produce and firm-ware string
Write EEPROM	0x50	EEPROM address	EEPROM data	N/A	N/A	N/A	N/A	N/A	1XXXFFXF
Store key	0x4B	Key code (0-31)	LS byte	Byte 2	Byte 3	Byte 4	Byte 5	MS byte	1XXXFFXF

The status flag returned by the acknowledge byte are as follows:

b7	b6	b5	b4	b3	b2	b1	b0	
1	1	1	1	1	1	1	1	
								EEPROM error (internal EEPROM write error)
								Card OK (card serial number matched to identity code list)
								Rx OK (card communication and acknowledgement OK)
								RS232 error (host serial communication error)
								MF type (0 = MF 1K byte card, 1 = MF 4K byte card)
								UL type (0 = MF standard 1K/4K card, <b>SINGLE UID</b> ), 1 = MF ultralight card, <b>DOUBLE UID</b> )
								MFRC error (internal or antenna fault)

More commands can be found in the RFID module datasheet.



# Circuit diagram

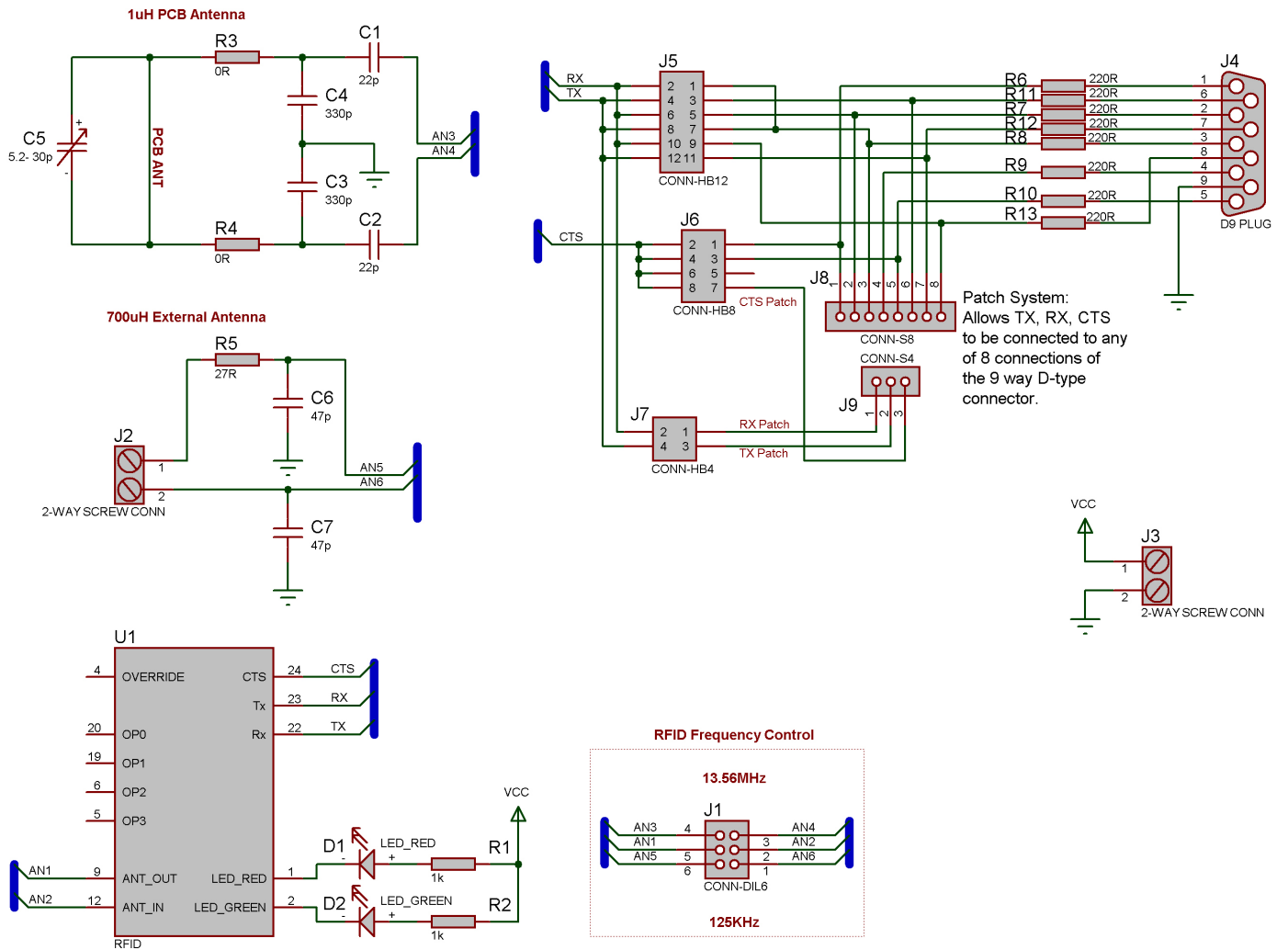



Matrix Technology Solutions Ltd.  
The Factory  
33 Gibbet Street  
Halifax, HX1 5BA, UK

t: +44 (0)1422 252380  
e: sales@matrixtsl.com

[www.matrixtsl.com](http://www.matrixtsl.com)

EB052-30-1