

2 x 2.2mm Pitch, Wire-to-Wire Connectors for Small Spaces

DF62 Series / DF62W Series

(UL, C-UL Listed)

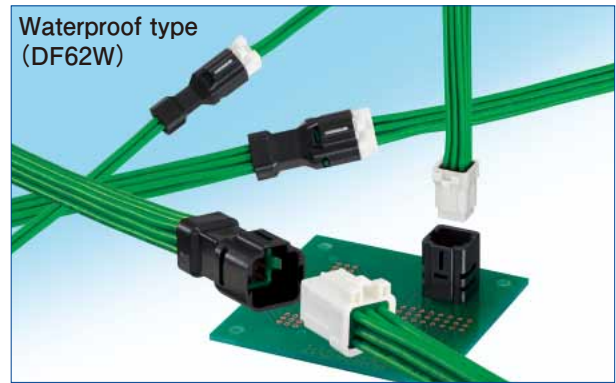
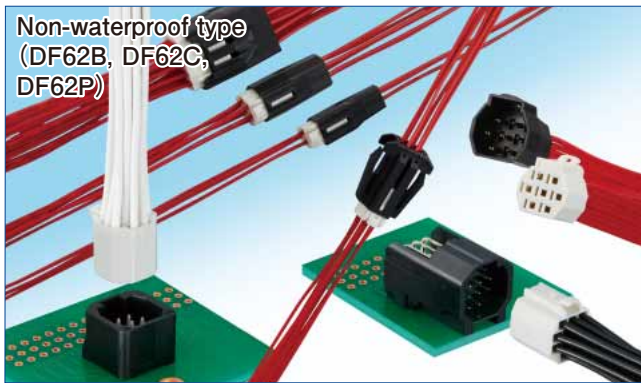

Features

1. The slim, sleek design and smooth contour combine to complete connections in tight spaces.

These connectors were designed to take full advantage of small/narrow spaces. The contacts are arranged in a grid pattern which shortens the diagonal distances and the body was slimmed down by creating smooth outer surfaces. This design helps to save precious space and makes these connectors virtually tangle free. There is no visible or exposed metal which would eliminate the possibility of electrical arcing between the connector and the inside of a metal conduit. (Please refer to Fig. 1 and 2)

2. Secure lock mechanism

The locking structure emits a clear tactile click upon lock completion. After completion, a second indicator can be utilized. The socket lock can be visually checked through the plug window after mating. These indicators function together to prevent incomplete mating. (Please refer to Fig. 3)

3. Reliable contact structure

The structure utilizes two contact points to provide a reliable contact that resists damage from vibration and rough operation.

4. Robust contact structure

The unique structure provides protection to the contacts and lance areas, it prevents any bending or deformity that might occur during mating, the assembly procedure or while in transportation. (Please refer to Fig. 4)

5. Multiple variations available

There are several different wire counts available, giving the designer the variety needed to complete the application. Protected lock type, panel mount type and pin header type are also available.

6. Applicator sharing

The applicators for the DF11 and DF59 series (existing products) can be adapted to accommodate the DF62 series applicators. *Some modifications are required. Please contact Hirose for additional details.

7. Water-resistant type (DF62W)

IP67 water-resistance occurs only in the mated condition. (Please refer to Fig. 5)

Compact shape due to 2 x 2.2 grid layout of pins
*Both are 7 contacts with 3A current rating

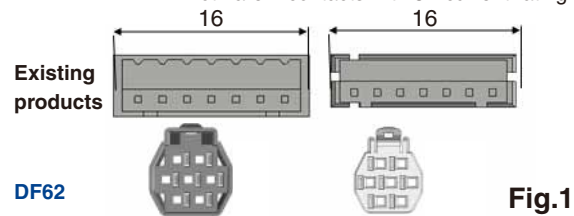

Grid Arrangement Smooth external shape No exposed metal



Visual check for complete mating



Image of the outward appearance of the contact
(For non-water-proof type)

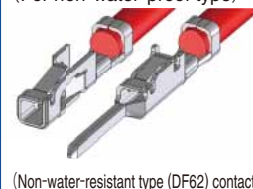

(Water-resistant type (DF62W))
Robust box-shaped contact structure

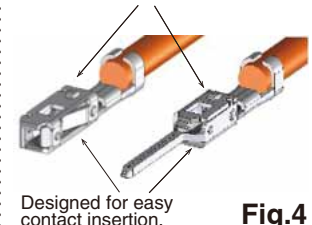

Condensation prevention measure
(Water-resistant type, IP67 rated)



Product Specifications

Ratings	DF62	Current Rating (Note 1)	22 AWG : 4A/pin (2 pos.) 3A/pin (3 - 13 pos.) 2.5A/pin (24 pos.)			Operating Temperature Range	-35 to 105°C (Note 2) UL/C-UL -35 to 75°C (Note 2, 5)
			24 AWG : 2A/pin 26-30 AWG : 1A/pin			Operating Humidity Range	20 ~ 80% (Note 3)
	DF62W	Current Rating (Note 1)	20 AWG : 5A (2 pos.), 3.5A/pin (3 to 9 pos) 22 AWG : 4A (2 pos.), 3A/pin (3 to 9 pos) 24 AWG : 3.5A (2 pos.), 2A/pin (3 to 9 pos) 26 AWG : 3A (2 pos.), 1A/pin (3 to 9 pos)			Operating Temperature Range	-40 to 105°C (Note 2) UL/C-UL -40 to 75°C (Note 2, 5)
						Operating Humidity Range	20 to 80% (Note 3)
	Common	Voltage Rating	Specifications	AC/DC 250V	UL File name UL : E52653 C-UL : E52653	Storage Temperature Range	-10 to 60°C (Note 4)
			UL/C-UL (Note 5)	AC/DC 29.9V		Storage Humidity Range	40 to 70% (Note 4)

Items	Specifications	Conditions
1. Insulation Resistance	Minimum of 1,000MΩ	Measured with DC 500V
2. Withstanding Voltage	No flashover or breakdown	Apply AC 650V for 1 minute
3. Contact Resistance	Maximum of 30mΩ	Measured at a maximum of 20mV and 100mA (DC or 1000Hz)
4. Vibration Resistance	No electrical discontinuity of 1μs or longer	10 cycles in each of three directions at frequency 10-55Hz, half amplitude 0.75mm
5. Shock Resistance	No electrical discontinuity of 1μs or longer	Acceleration : 490m/s ² , 11 ms, Semi-sinusoidal 3 axle direction 3 times each.
6. Humidity Resistance	Contact Resistance Maximum of 30mΩ Insulation Resistance : Minimum of 1,000MΩ	Left at temperature 40 ±2°C, humidity 90 to 95%, 96 hours
7. Temperature Cycles	Contact Resistance : Maximum of 30mΩ Insulation Resistance : Minimum of 1,000MΩ	-55°C : 30 minutes → 5 to 35°C : 2 to 3 minutes → 85°C : 30 minutes → 5 to 35°C : 2 to 3 minutes, 5 cycles
8. Durability	Contact Resistance : Maximum of 30mΩ	Mating/unmating : 30 mating cycles

Note 1 : This is the maximum current rating while all pins are powered or used as all power lines. When isolating power lines into multiple circuits, current ratings may go above the stated current ratings. Please consult Hirose for specific details before doing this.

Note 2 : Includes the temperature rise of power lines

Note 3 : The connector should be completely dry (no condensation present)

Note 4 : The term "storage" refers to the long-term storage condition of unused products before PCB mounting. The operating temperature and humidity ranges are applied while in a non-energized state, while in transport or after PCB mounting.

Note 5 : Header type are UL/C-UL pending.

Materials / Finish

Item	Component	Material	Finish	UL Flammability rating	
Socket crimping contact	Contact	Phosphorous bronze	Gold plating or tin plating	-	
Plug crimping contact	Contact	Phosphorous bronze	Gold plating or tin plating	-	
Crimping socket	Insulator	PBT	White	UL94V-0	
Crimping plug	Insulator	PBT	Black	UL94V-0	
Crimping socket *	Seal	Silicone rubber	Bengala	-	
Crimping plug *					
Header	Insulator	DF62	Straight pin header : Polyamide Right angle pin header : PBT	Black	UL94V-0
		DF62W			
	Contact	Copper alloy		Gold plating or tin plating	-
	Metal fitting	Brass		Tin plating	-
	Seal *	Silicone rubber		Bengala	-

*Waterproof type (DF62W) only

◆IP67 Water-resistant type

●Connector

DF 62W - * S - 2.2 C

① ② ③ ④ ⑤ ⑥

① Series Name : DF	⑤ Contact pitch : 2.2mm
② Series No. : 62W	
③ No. of Contacts : 2, 3, 4, 6, 9	⑥ Connection part shape C : Crimping housing
④ Connector type S : Socket, EP : Extension plug	

●Contact

DF 62W - EP 2226 PCF A

① ② ③ ④ ⑤ ⑥

① Series Name : DF	⑤ Contact type /packaging type SCF : Socket crimping contact, reel SC : Socket crimping contact, pieces PCF : Plug crimping contact, reel PC : Plug crimping contact, pieces
② Series No. : 62W	
③ Terminal type EP : Extension plug	⑥ Plating type A : Gold plating None : Tin plating
④ Applicable wire size 2022 : 20 to 22 AWG 2226 : 22 to 26 AWG	

●Water-proof pin

DF 62W - WP

① ② ③

① Series Name : DF	③ For each use type WP : ◆IP67 Water-resistant type
② Series No. : 62W	

●Connector

DF 62W - * P - 2.2 DSA (00)

① ② ③ ④ ⑤ ⑥ ⑦

① Series Name : DF	⑤ Contact pitch : 2.2mm
② Series No. : 62W	⑥ Connection part shape DSA : Straight pin header
③ No. of Contacts : 9	
④ Connector type P : Header	⑦ Plating type (01) : Gold plating

Socket (standard type)

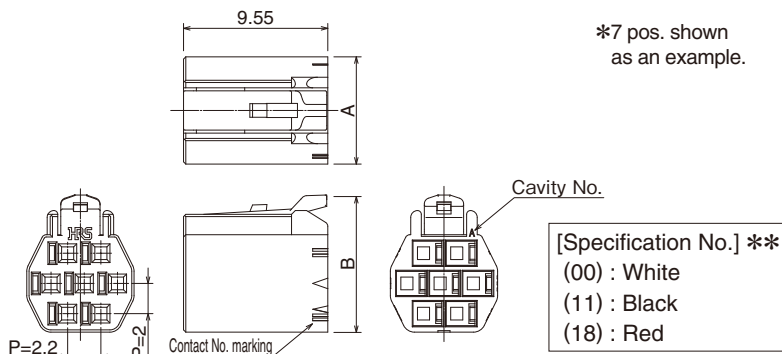

Unit : mm

Part No.	HRS No.	No. of Contacts	A	B	Part No.	HRS No.	No. of Contacts	A	B
DF62B-2S-2.2C(**)	544-0551-0 **	2	4.9	5.08	DF62B-6S-2.2C(**)	544-0555-0 **	6	7.1	7.08
DF62B-3S-2.2C(**)	544-0552-2 **	3		7.08	DF62B-7S-2.2C(**)	544-0556-3 **	7		9.08
DF62B-4S-2.2C(**)	544-0553-5 **	4	7.1	7.08	DF62B-13S-2.2C(**)	544-0557-6 **	13	9.3	11.08
DF62B-5S-2.2C(**)	544-0554-8 **	5			12.3	13.08			

Note 1 : This product is sold per pack (100pcs/pack), please place orders in full pack increments.

Socket (Protected lock type)

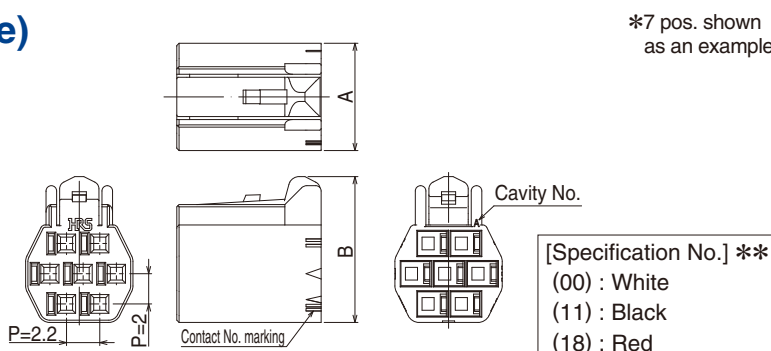

Unit : mm

Part No.	HRS No.	No. of Contacts	A	B	Part No.	HRS No.	No. of Contacts	A	B
DF62C-2S-2.2C(**)	544-0565-4 **	2	4.9	5.65	DF62C-6S-2.2C(**)	544-0569-5 **	6	7.1	7.65
DF62C-3S-2.2C(**)	544-0566-7 **	3		7.65	DF62C-7S-2.2C(**)	544-0570-4 **	7		9.65
DF62C-4S-2.2C(**)	544-0567-0 **	4	7.1	7.65	DF62C-13S-2.2C(**)	544-0571-7 **	13	9.3	11.65
DF62C-5S-2.2C(**)	544-0568-2 **	5			12.3	13.65			

Note 1 : This product is sold per pack (100pcs/pack), please place orders in full pack increments.

Socket (Water proof type)

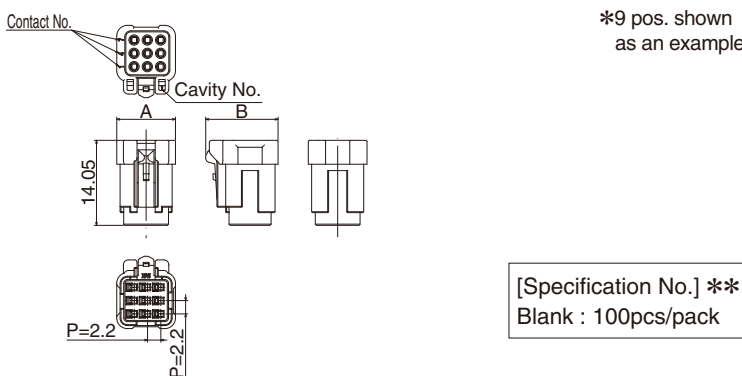

Unit : mm

Part No.	HRS No.	No. of Contacts	A	B	Part No.	HRS No.	No. of Contacts	A	B
DF62W-2S-2.2C	544-1002-7 00	2	7.5	7.55	DF62W-6S-2.2C	544-1008-3 00	6	9.7	9.75
DF62W-3S-2.2C	544-1004-2 00	3		9.75	DF62W-9S-2.2C	544-1010-5 00	9		11.95
DF62W-4S-2.2C	544-1006-8 00	4							

Note 1 : This product is sold per pack (100pcs/pack), please place orders in full pack increments.

Note 2 : The Water-proof type and a non-water-proof type are not intermateable.

Pin configuration of the contact numbers. (Shown from the mating side.)

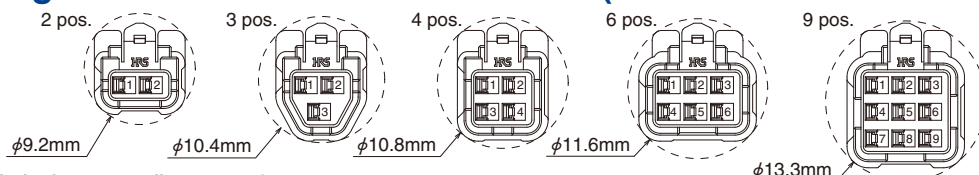

Note : Applicable jacket outer diameter : φ1.4 to 1.6mm

■ Plug (standard type)

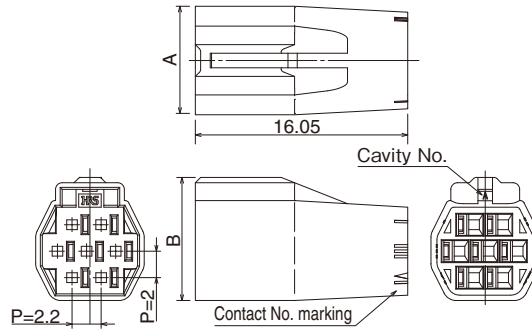
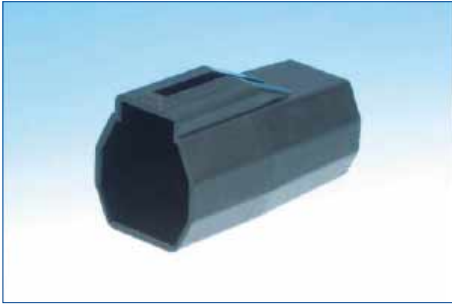

*7 pos. shown as an example.

[Specification No.] **
(00) : Black
(10) : White
(18) : Red

Unit : mm

Part No.	HRS No.	No. of Contacts	A	B	Part No.	HRS No.	No. of Contacts	A	B
DF62B-2EP-2.2C(**)	544-0558-9 **	2	6.0	5.3	DF62B-6EP-2.2C(**)	544-0562-6 **	6	8.2	7.3
DF62B-3EP-2.2C(**)	544-0559-1 **	3		7.3	DF62B-7EP-2.2C(**)	544-0563-9 **	7		9.3
DF62B-4EP-2.2C(**)	544-0560-0 **	4	8.2	7.3	DF62B-13EP-2.2C(**)	544-0564-1 **	13	10.4	11.3
DF62B-5EP-2.2C(**)	544-0561-3 **	5			13.4	13.3			

Note 1 : This product is sold per pack (100pcs/pack), please place orders in full pack increments.

■ Plug (Panel mount type)

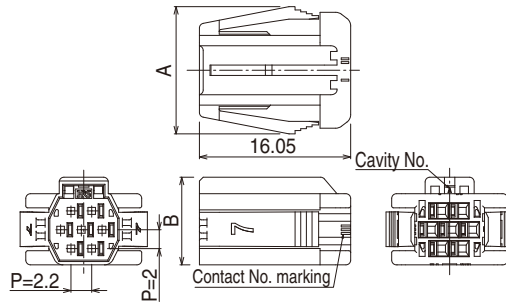

[Specification No.] **
(00) : Black
(10) : White
(18) : Red

Unit : mm

Part No.	HRS No.	No. of Contacts	A	B	Part No.	HRS No.	No. of Contacts	A	B
DF62P-2EP-2.2C(**)	544-0543-1 **	2	11.3	5.3	DF62P-6EP-2.2C(**)	544-0547-2 **	6	13.5	7.3
DF62P-3EP-2.2C(**)	544-0544-4 **	3		7.3	DF62P-7EP-2.2C(**)	544-0548-5 **	7		9.3
DF62P-4EP-2.2C(**)	544-0545-7 **	4	13.5	7.3	DF62P-13EP-2.2C(**)	544-0549-8 **	13	15.7	11.3
DF62P-5EP-2.2C(**)	544-0546-0 **	5			18.7	13.3			

Note 1 : This product is sold per pack (100pcs/pack), please place orders in full pack increments.

■ Plug (Water proof type)

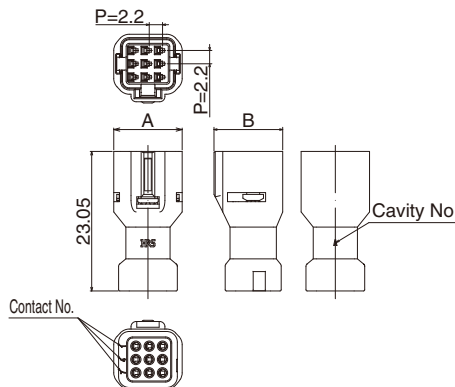

*9 pos. shown as an example.

Unit : mm

Part No.	HRS No.	No. of Contacts	A	B	Part No.	HRS No.	No. of Contacts	A	B
DF62W-2EP-2.2C	544-1003-0 00	2	7.5	6.7	DF62W-6EP-2.2C	544-1009-6 00	6	11.3	9.15
DF62W-3EP-2.2C	544-1005-5 00	3	8.0	9.15	DF62W-9EP-2.2C	544-1011-8 00	9		11.35
DF62W-4EP-2.2C	544-1007-0 00	4	9.1						

Note 1 : This product is sold per pack (100pcs/pack), please place orders in full pack increments.

Note 2 : The Water-proof type and a non-water-proof type are not intermateable.

◆ Pin configuration of the contact numbers. (Shown from the mating side.)

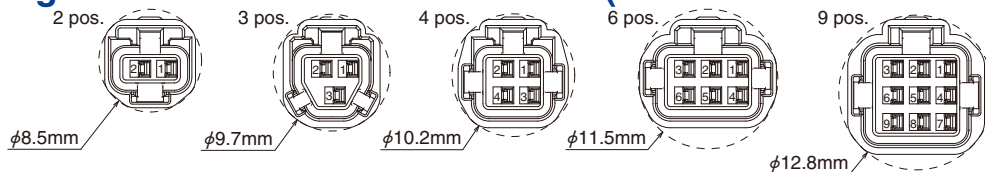

Note : Applicable jacket outer diameter : φ1.4 to 1.6mm

◆ Socket contact No. Summary diagram (from the mating section side)

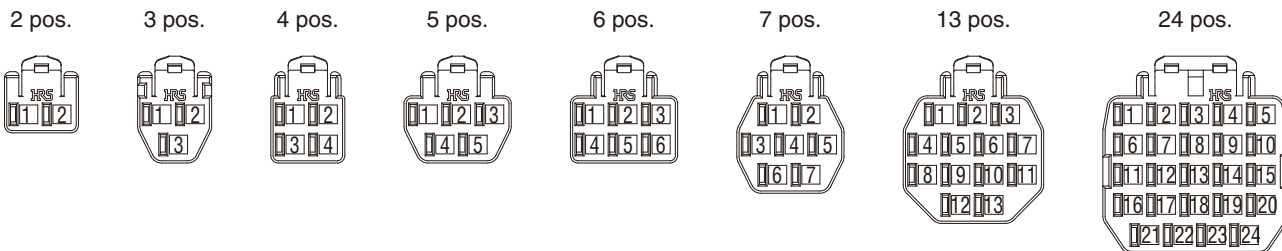

◆ Plug contact No. Summary diagram (from the mating section side)

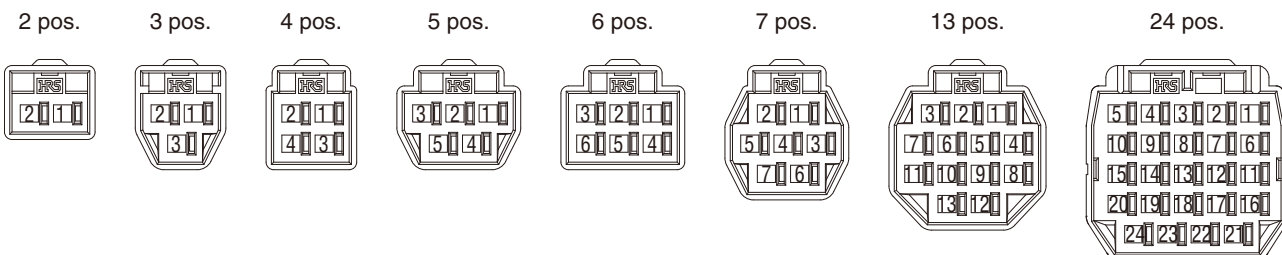

◆ Contact No. diagram

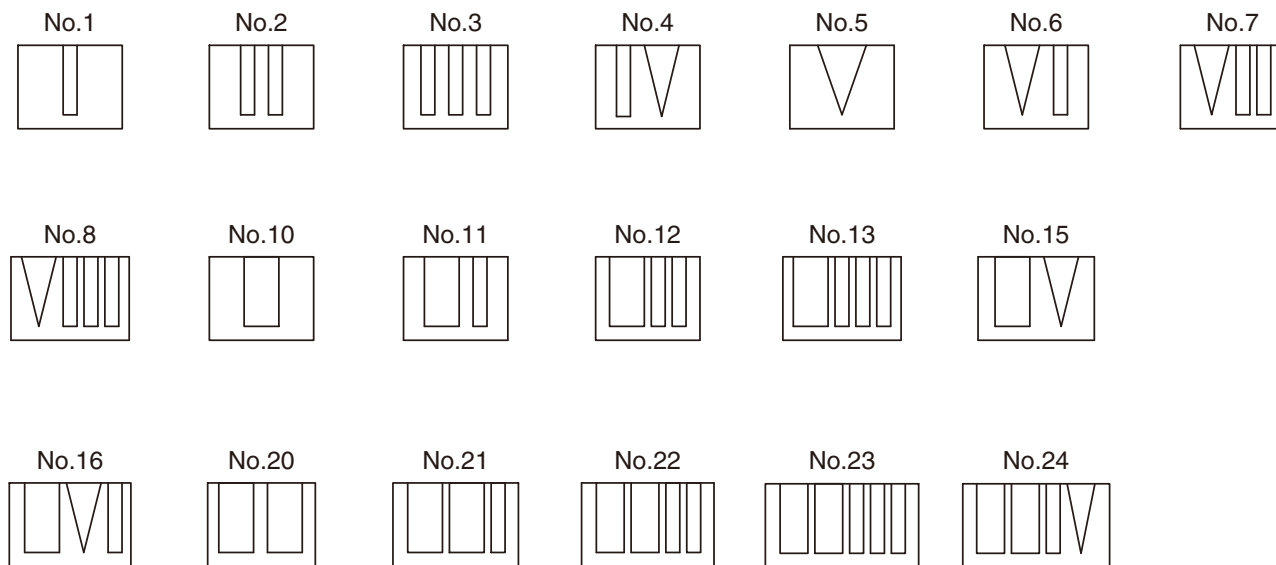

■ Socket crimping contact

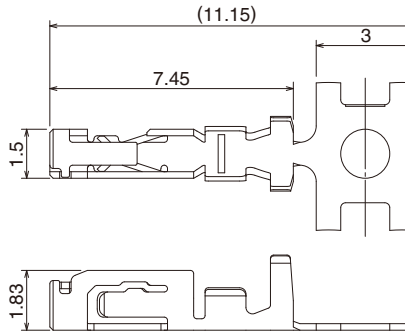

Unit : mm

Part No.	HRS No.	Packaging type	Quantity	Finish	
DF62-22SCFA	544-0506-5 00	Reel contact (Note 1)	15,000 pcs/reel	Selective gold plating	
DF62-2428SCFA	544-0500-9 00				
DF62-30SCFA	544-0508-0 00	Loose piece (Note 2)	100 pcs/pack		
DF62-22SCA	544-0526-2 00				
DF62-2428SCA	544-0527-5 00	Reel contact (Note 1)	15,000 pcs/reel		Tin plating
DF62-30SCA	544-0528-8 00				
DF62-22SCF	544-0520-6 00	Loose piece (Note 2)	100 pcs/pack		
DF62-2428SCF	544-0521-9 00				
DF62-30SCF	544-0522-1 00	Reel contact (Note 1)	15,000 pcs/reel		
DF62-22SC	544-0572-0 00				
DF62-2428SC	544-0573-2 00	Loose piece (Note 2)	100 pcs/pack		
DF62-30SC	544-0574-5 00				

Note 1 : This product is sold in full reel quantities (15,000pcs/reel), please place orders in full reel increments.

Note 2 : This product is sold per pack (100pcs/pack), please place orders in full pack increments.

● Applicable wire (Tinned Annealed Copper Wire)

Conductor size (Core structure)	Insulation diameter	UL	Strip length
22 AWG (17/φ0.16mm)	φ1.2 to φ1.45mm	UL1061	1.7 to 2.3mm
24 AWG (11/φ0.16mm)			
26 AWG (7/φ0.16mm)	φ0.9 to φ1.45mm	UL1007	
28 AWG (7/φ0.127mm)			
30 AWG (7/φ0.1mm)	φ0.75 to φ1.2mm	UL1061	

Note : When using wires that are not recommended by Hirose, please contact one of our sales representatives for clarification.

■ Socket crimp contact (for water-proof version)

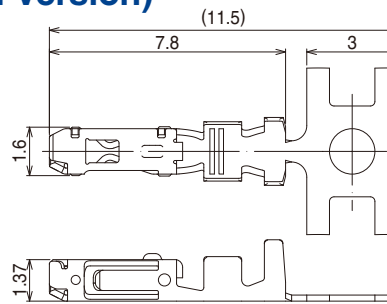
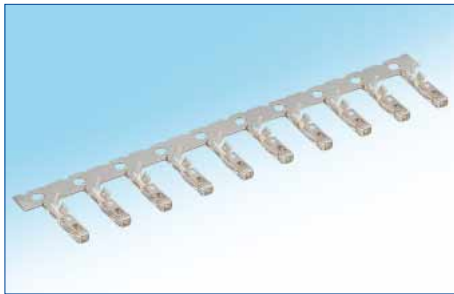

Unit : mm

Part No.	HRS No.	Packaging type	Quantity	Finish
DF62W-2022SCF	544-1015-9 00	Reel contact (Note 1)	15,000 pcs/reel	Tin plating
DF62W-2022SC	Under planning	Loose piece (Note 2)	100 pcs/pack	
DF62W-2022SCFA	544-1027-0 00	Reel contact (Note 1)	15,000 pcs/reel	Gold plating
DF62W-2022SCA	Under planning	Loose piece (Note 2)	100 pcs/pack	
DF62W-2226SCF	544-1000-1 00	Reel contact (Note 1)	15,000 pcs/reel	Tin plating
DF62W-2226SC	544-1012-0 00	Loose piece (Note 2)	100 pcs/pack	
DF62W-2226SCFA	544-1025-0 00	Reel contact (Note 1)	15,000 pcs/reel	Gold plating
DF62W-2226SCA	Under planning	Loose piece (Note 2)	100 pcs/pack	

Note 1 : This product is sold in full reel quantities (15,000pcs/reel), please place orders in full reel increments.

Note 2 : This product is sold per pack (100pcs/pack), please place orders in full pack increments.

● Applicable wire (Tinned Annealed Copper Wire)

Conductor size (Core structure)	Insulation diameter	UL	Strip length
20 AWG (7/φ0.32mm)	φ1.4 to φ1.6mm	UL3443	1.7 to 2.3mm
22 AWG (17/φ0.16mm)		UL1007	
24 AWG (11/φ0.16mm)		UL1007	
		UL1430	
26 AWG (7/φ0.16mm)		UL1430	

Note 1 : When using wires that are not recommended by Hirose, please contact one of our sales representatives for clarification.

Note 2 : The Water-proof type and non-water-proof type are not intermateable.

■ Plug crimping contact

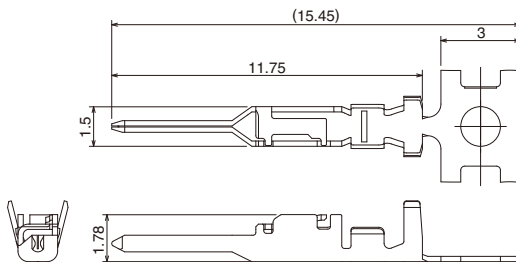

Unit : mm

Part No.	HRS No.	Packaging type	Quantity	Finish
DF62-EP22PCFA	544-0507-8 00	Reel contact (Note 1)	15,000 pcs/reel	Selective gold plating
DF62-EP2428PCFA	544-0501-1 00			
DF62-EP30PCFA	544-0509-3 00	Single contact (Note 2)	100 pcs/pack	
DF62-EP22PCA	544-0529-0 00			
DF62-EP2428PCA	544-0530-0 00	Reel contact (Note 1)	15,000 pcs/reel	Tin plating
DF62-EP30PCA	544-0531-2 00			
DF62-EP22PCF	544-0523-4 00	Single contact (Note 2)	100 pcs/pack	
DF62-EP2428PCF	544-0524-7 00			
DF62-EP30PCF	544-0525-0 00	Reel contact (Note 1)	15,000 pcs/reel	
DF62-EP22PC	544-0575-8 00			
DF62-EP2428PC	544-0576-0 00	Single contact (Note 2)	100 pcs/pack	
DF62-EP30PC	544-0577-3 00			

Note 1 : This product is sold in full reel quantities (15,000pcs/reel), please place orders in full reel increments.

Note 2 : This product is sold per pack (100pcs/pack), please place orders in full pack increments.

● Applicable wire (Tinned Annealed Copper Wire)

Conductor size (Core structure)	Insulation diameter	UL	Strip length
22 AWG (17/φ 0.16mm)	φ1.2 to φ1.45mm	UL1061	1.7 to 2.3mm
24 AWG (11/φ 0.16mm)		UL1007	
26 AWG (7/φ 0.16mm)	UL1061		
28 AWG (7/φ 0.127mm)			
30 AWG (7/φ 0.1mm)	φ0.75 to φ1.2mm		

Note : When using wires that are not recommended by Hirose, please contact one of our sales representatives for clarification.

■ Plug crimping contact (for water-proof version)

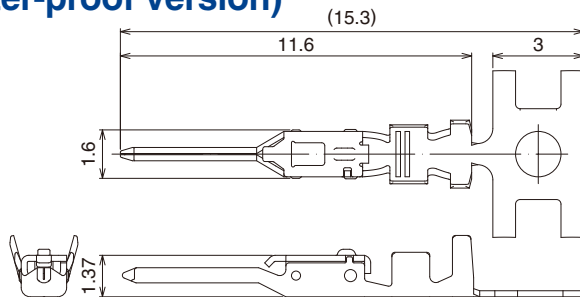
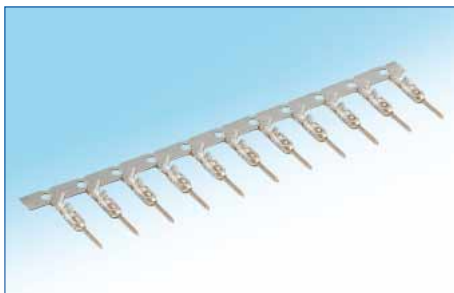

Unit : mm

Part No.	HRS No.	Packaging type	Quantity	Finish
DF62W-EP2022PCF	544-1016-1 00	Reel contact (Note 1)	15,000 pcs/reel	Tin plating
DF62W-EP2022PC	Under planning	Single contact (Note 2)	100 pcs/pack	
DF62W-EP2022PCFA	544-1028-0 00	Reel contact (Note 1)	15,000 pcs/reel	Gold plating
DF62W-EP2022PCA	Under planning	Single contact (Note 2)	100 pcs/pack	
DF62W-EP2226PCF	544-1001-4 00	Reel contact (Note 1)	15,000 pcs/reel	Tin plating
DF62W-EP2226PC	544-1013-2 00	Single contact (Note 2)	100 pcs/pack	
DF62W-EP2226PCFA	544-1026-0 00	Reel contact (Note 1)	15,000 pcs/reel	Gold plating
DF62W-EP2226PCA	Under planning	Single contact (Note 2)	100 pcs/pack	

Note 1 : This product is sold in full reel quantities (15,000pcs/reel), please place orders in full reel increments.

Note 2 : This product is sold per pack (100pcs/pack), please place orders in full pack increments.

● Applicable wire (Tinned Annealed Copper Wire)

Conductor size (Core structure)	Insulation diameter	UL	Strip length
20 AWG (7/φ0.32mm)	φ1.4 to φ1.6mm	UL3443	1.7 to 2.3mm
22 AWG (17/φ0.16mm)		UL1007	
24 AWG (11/φ0.16mm)		UL1007 UL1430	
26 AWG (7/φ0.16mm)		UL1430	

Note 1 : When using wires that are not recommended by Hirose, please contact one of our sales representatives for clarification.

Note 2 : The Water-proof type and non-water-proof type are a not intermateable.

◆ Applicable Crimping Tool

● DF62

Type	Part No.	HRS No.	Applicable Contact
Applicator	AP105-DF62-22	901-4626-3 00	DF62-22SCFA/SCF DF62-EP22PCFA/PCF
	AP105-DF62-2428	901-4625-0 00	DF62-2428SCFA/SCF DF62-EP2428PCFA/PCF
	AP105-DF62-30	901-4627-6	DF62-30SCFA/SCF DF62-EP30PCFA/PCF
Press body	CM-105C	901-0001-0 00	-
Hand tool	HT801/DF62-22(10) (Note 2)	550-0401-9 10	DF62-22SCA/SC DF62-EP22PCA/PC
	HT801/DF62-2428(10) (Note 3)	550-0400-6 10	DF62-2428SCA/SC DF62-EP2428PCA/PC
	HT801/DF62-30(10) (Note 4)	550-0402-1 10	DF62-30SCA/SC DF62-EP30PCA/PC
Extraction tool	DF62/RE-MD	902-4645-4 00	DF62-**SCFA/SCF/SCA/SC DF62-EP**PCFA/PCF/PCA/PC

Note 1 : Hirose does not warranty problems that arise from the use of unapproved tools on Hirose products.

Note 2 : The compatible wire is limited to UL1061 (22 AWG).

Note 3 : The compatible wire is limited to UL1007 (24 to 28 AWG).

Note 4 : The compatible wire is limited to UL1061 (30 AWG).

● DF62W

Type	Part No.	HRS No.	Applicable Contact
Applicator	AP105-DF62W-2022	901-4500-0 00	DF62W-2022SCF(A)
	EHS899800H-UP (Note 2)	-	DF62W-EP2022PCF(A)
	AP105-DF62W-2226	901-4637-0 00	DF62W-2226SCF(A)
	EHS888400H-UP (Note 2)	-	DF62W-EP2226PCF(A)
Press body	CM-105C	901-0001-0 00	-
Hand tool	HT802/DF62W-2022 (Note 3)	550-0431-0 00	DF62W-2022SC(A) DF62W-EP2022PC(A)
	HT802/DF62W-2226 (Note 4)	550-0416-6 00	DF62W-2226SC(A) DF62W-EP2226PC(A)
Extraction tool	DF62W/RE-MD	902-4666-4 00	DF62W-2022SC(F)(A) DF62W-EP2022PC(F)(A) DF62W-2226SC(F)(A) DF62W-EP2226PC(F)(A)

Note 1 : Hirose does not warranty problems that arise from the use of unapproved tools on Hirose products.

Note 2 : Applicator manufactured by JAPAN AUTOMATIC MACHINE(J.A.M.). Please access to HP of J.A.M., if you make inquiries about the applicator or crimp defect. (URL : <http://www.jam-net.co.jp>)

Note 3 : The compatible wire is limited to UL3443 (20 AWG) or UL1007 (22 AWG).

Note 4 : The compatible wire is limited to UL1007 (22 to 24 AWG) or UL1430 (24 to 26 AWG).

■ Straight pin Header



*13 pos. shown as an example.

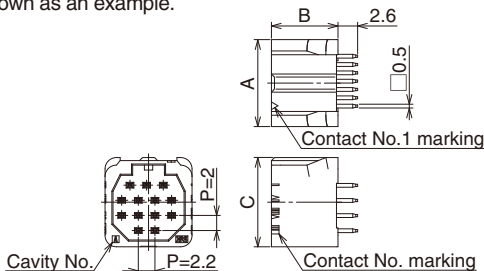

Unit : mm

Part No.	HRS No.	No. of Contacts	A	B	C
DF62-13P-2.2DSA(**)	544-0582-0 **	13	11.5	8.8	11.8
DF62-24P-2.2DSA(**)	544-0584-0 **	24	14.5	10.8	13.8

[Specification No.] **
(00) : Tin plating

Note 1 : This product is sold per tray (13pos : 100pcs/tray, 24pos : 80pcs/tray), please place orders by tray unit.

● Recommended PCB layout (Recommended thickness t=1.6mm)

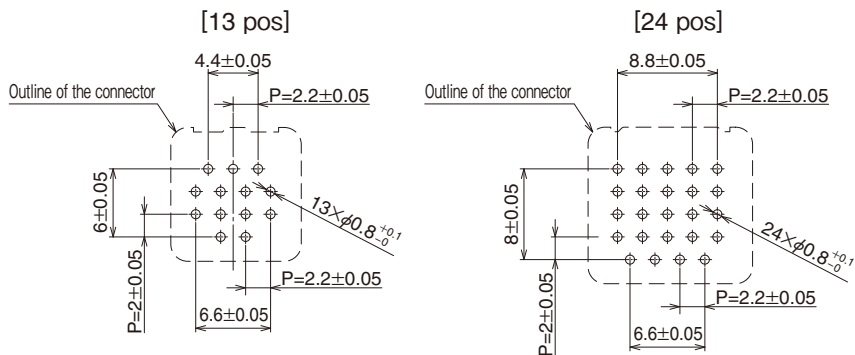

■ Right Angle pin Header



*13 pos. shown as an example.

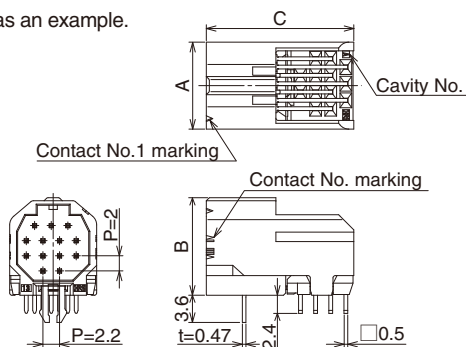

Unit : mm

Part No.	HRS No.	No. of Contacts	A	B	C
DF62-13P-2.2DS(**)	544-0581-0 **	13	11.5	12.9	19.5
DF62-24P-2.2DS(**)	544-0583-0 **	24	15.4	14.9	23.5

[Specification No.] **
(00) : Tin plating

Note 1 : This product is sold per tray (100pcs/tray), please place orders by tray unit.

● Recommended PCB layout (Recommended thickness t=1.6mm)

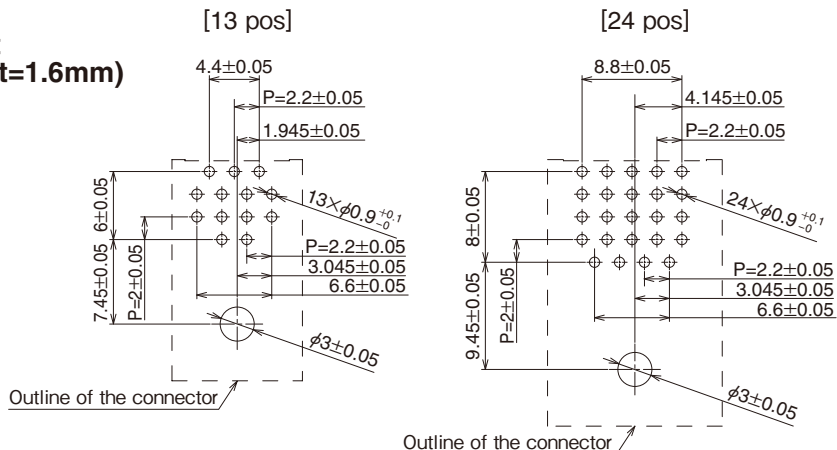

■ Straight pin Header (Water proof type)



*9 pos. shown as an example.

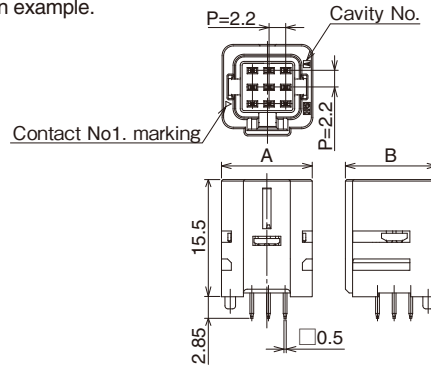

Unit : mm

Part No.	HRS No.	No. of Contacts	A	B
DF62W-9P-2.2DSA(**)	544-1024-0 **	9	12	12.1

[Specification No.] **
(01) : Gold plating

Note 1 : This product is sold per tray (200pcs/tray), please place orders by tray unit.

● Recommended PCB layout (Recommended thickness t=1.6mm)

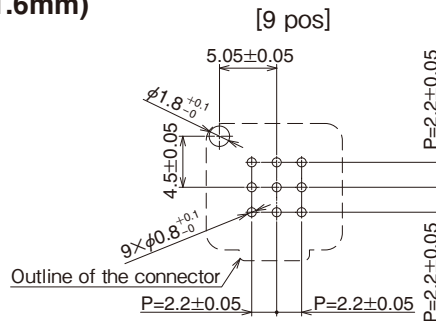

◆ Operating Precautions

- Do not tilt the crimping contact while it is being inserted into the plug, this can lead to damage of the contacts and will downgrade its performance.
For precautions when handling the harness, please refer to the “DF62 Series Cable Assembly Procedures” or “DF62W Series Cable Assembly Procedures”.
- The color of the resin on these connectors may vary depending on the manufacturing lot. This variance will not affect the connector’s performance.
- For precautions relating to insertion and extraction of this connector, please refer to the “DF62 Series Inserting/Extracting Procedures” or “DF62W Series Inserting/Extracting Procedures”.



HIROSE ELECTRIC CO.,LTD.

2-6-3,Nakagawa Chuoh,Tsuzuki-Ku,Yokohama-Shi 224-8540,JAPAN
TEL: +81-45-620-3526 Fax: +81-45-591-3726
<http://www.hirose.com>
<http://www.hirose-connectors.com>