

3M™ Jupiter™ Powered Air Turbo Unit Care and Maintenance



To maintain protection levels, optimise the effective lifetime of the system and avoid the additional cost of replacement, it is extremely important to carry out regular checks and maintenance on Powered and Supplied Air Respirators.

Before Use

- Ensure Battery is fully charged.
- Ensure Turbo is undamaged.
- Ensure Turbo is correctly secured to its belt.
- Ensure Filters are correctly fitted.
- Perform airflow check – insert Airflow Indicator Tube (white ball) into the turbo outlet, switch on, ensure ball rises above the line. If the ball does not rise above the line replace the filters.

Monthly

- Carry out all the 'Before Use' inspections and create record of this monthly check for the regulator.
- Calibrate turbo as per guidance box to right.

After Use

- Clean casing with cloth dampened with a mild solution of water and liquid household soap.
- Disinfect with 3M™ 105 Wipes.
- Change Battery.
- Store in a dry, clean area / locker away from direct sunlight, high temperatures and solvents.

Every Filter Change

- Ensure Filter Gaskets are undamaged and correctly fitted.
- Always replace Filters as a pair and ensure you feel them click into place.

Additional Checks for IS Kit

- Ensure 3M™ Jupiter™ IS Pouch is undamaged – inspect for holes and split seams.
- Ensure 3M Jupiter IS Pouch is correctly folded and sealed.

Ordering Consumables, Repair Parts and Accessories

To request a quote or place an order for these items, please contact your 3M Approved Distributor.

Further Information and Advice

If you require additional guidance on the Care and Maintenance of your 3M Powered and Supplied Air Equipment, please contact the Helpline or your local 3M representative.

The powered air turbo for protection against gas and vapour and/or particulates. The 3M Jupiter connects to a wide range of hoods, visors, helmets and welding shields to suit most industrial applications.

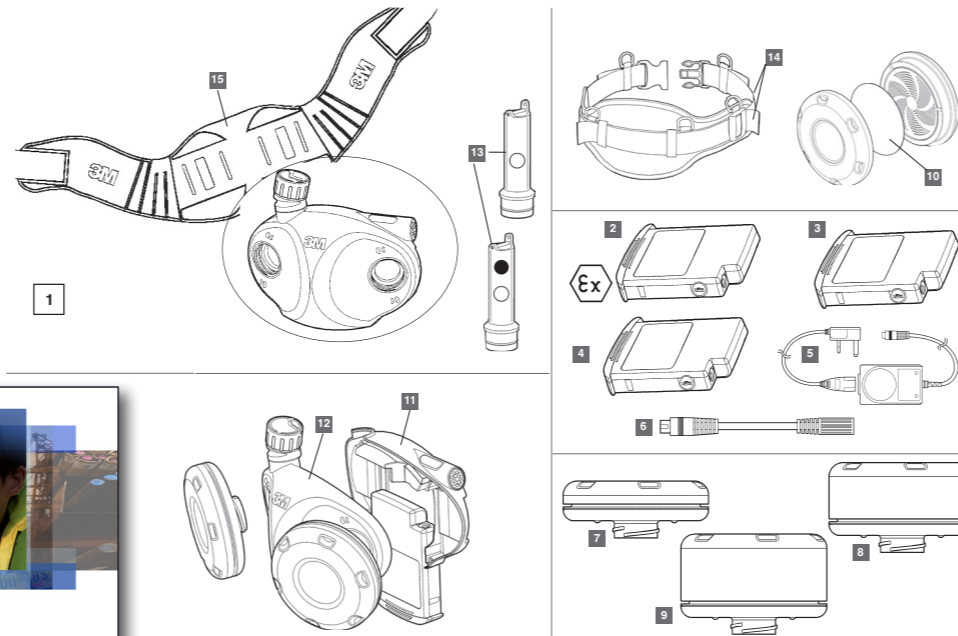

The Power to Protect Your World

3M Health & Safety Helpline
Monday - Friday 9 to 5
0870 60 800 60 UK
1 800 320 500 IRELAND

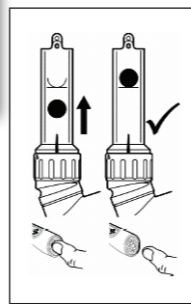

- ### Calibration
- Ensure the battery is fully charged. Remove Filters and insert Calibration Tube (black ball) into the turbo outlet
 - Hold turbo with the line on the tube at eye level
 - Press and hold the switch. After approximately 3 seconds the turbo will beep and enter calibration mode
 - The ball will drop to the bottom of the tube. As the fan speed increases, the ball will begin to rise
 - Release the switch when the bottom of the ball is on the line

		3M Part No
1	Jupiter Turbo Unit (includes BLT-12 belt, calibration tube and airflow indicator tube)	085-00-10P
	Jupiter Powered Air Turbo Kit contains a standard Jupiter Powered Turbo Unit, a pair of Organic Vapour and Particulate (A2P) filters, Pre-filters, Lightweight Breathing Tube, 8hr Rechargeable Battery (NiMH) and a Battery Charger	RTUJUPITER
3	4 hour battery	007-00-63P
4	8 hour battery	007-00-64P
2	Jupiter Intrinsically Safe (IS) Battery and Pouch Kit	085-12-00P
	Jupiter IS Pouch	085-11-00P
	Standard charger	003-00-56P
5	Intelligent charger – single station (for use with, 007-00-62P, 007-00-63P and 007-00-64P)	CHG-02
	Jupiter IO Station Intelligent Charger	003-00-59P
11	Control module	085-06-10P
12	Blower module (plus spare filter gaskets)	085-01-00P
13	Calibration tube and airflow indicator tube	021-14-12P
14	Comfort belt	022-25-03P4
15	Decontamination comfort belt (incl. 1 x BLT-14 and BLT-16)	BLT-12
	Braces	TR-329
7	Particulates P filters	450-00-25P2x12
8	A2P filters	453-00-25P2x6
9	A2BEK1P filters	453-09-25P2x6
8	ABE1P filters	456-18-25P2x6
10	Pre-filter pads	461-00-02P24x5

@3M_UK_Safety

3M Personal Safety Division
3M United Kingdom plc
3M Centre
Cain Road, Bracknell
Berkshire RG12 8HT
Tel: 0870 60 800 60
www.3M.co.uk/Safety

3M Ireland Limited
The Iveagh Building
The Park
Carrickmines
Dublin 18
Tel: 1 800 320 500

17808
3M and Jupiter are trademarks of 3M Company
Please recycle. Printed in UK.
© 3M 2014. All rights reserved.

**REPLACE ALL DAMAGED PARTS IMMEDIATELY TO ENSURE
CORRECT LEVELS OF PROTECTION**



CHJUPITERCMP

To download this poster please visit:
www.3M.co.uk/maintenancepack or scan the QR code

