

# PSR-MS50 / PSR-MS55

PL  
EN ISO 13849

SILCL  
IEC 62061

## Safety relays for monitoring non-equivalent signal generators



Data sheet  
106170\_en\_01

© PHOENIX CONTACT 2015-05-19

## 1 Description

### Intended Use

The **PSR-MC50** and **PSR-MS55** safety relays can be used to monitor two-channel non-equivalent signal generators, e.g., magnetic switches, as well as to control actuators.

The safety relays are equipped with an enabling current path that drops out without delay according to stop category 0 in accordance with EN 60204-1.

In the case of the **PSR-MS50** safety relay, the enabling current path is controlled automatically once the sensor circuit for channel 1 has been closed and channel 2 has been opened.

In the case of the **PSR-MS55** safety relay, the enabling current path is controlled once the sensor circuit on channel 1 has been closed and channel 2 has been opened and then the manual reset device (reset button) has been pressed and released again (manual, monitored start).

With the manual, monitored reset device, a machine start may not be triggered in accordance with EN ISO 13849-1.

### Features

- Safety relays for monitoring non-equivalent signal generators, e.g., magnetic switches
- Suitable up to category 4, PL e (EN ISO 13849-1), SILCL 3 (EN 62061)
- 1 two-channel non-equivalent sensor circuit
- 1 undelayed enabling current path
- 1 digital signal output
- Fixed screw connection
- 6.8 mm housing width



#### **WARNING: Risk of electric shock**

Observe the safety instructions in the corresponding section!



Make sure you always use the latest documentation.  
It can be downloaded from the product at [phoenixcontact.net/products](http://phoenixcontact.net/products).



This data sheet meets the same requirements as the original operating instructions in terms of contents and is valid for all products listed on the following pages.

---

<b>2</b>	<b>Table of contents</b>	
1	Description .....	1
2	Table of contents .....	2
3	Ordering data .....	3
4	Technical data .....	3
5	Safety notes.....	6
6	Basic circuit diagram .....	7
	6.1 Block diagram PSR-MS50 .....	7
	6.2 Block diagram PSR-MS55 .....	7
7	Derating.....	7
	7.1 Vertical or horizontal mounting position .....	7
8	Load curve.....	7
	8.1 Ohmic load .....	7
9	Function/time diagrams .....	8
	9.1 Time diagram PSR-MS50 .....	8
	9.2 Time diagram PSR-MS55 .....	8
10	Operating and indication elements .....	9
	10.1 Connection versions .....	9
	10.2 Connection assignment.....	9
11	Mounting and connection .....	10
12	Startup.....	10
13	Calculating the power dissipation .....	11
14	Diagnostics.....	12
	14.1 General states .....	12
	14.2 Error Messages.....	12
15	Application examples .....	13
	15.1 Magnetic switch monitoring/automatic start .....	13
	15.2 Magnetic switch monitoring/manual, monitored start.....	13
16	Revision history .....	14

### 3 Ordering data

Description	Type	Order No.	Pcs. / Pkt.
Safety relay for monitoring non-equivalent signal generators up to SIL 3, SILCL 3, Cat. 4, PL e, 2-channel, non-equivalent operation, automatic start, 1 enabling current path, $U_S = 24$ V DC, fixed screw terminal block	PSR-MS50-1NO-1DO-24DC-SC	2904956	1
Safety relay for monitoring non-equivalent signal generators up to SIL 3, SILCL 3, Cat. 4, PL e, 2-channel, non-equivalent operation, manual, monitored start, 1 enabling current path, $U_S = 24$ V DC, fixed screw terminal block	PSR-MS55-1NO-1DO-24DC-SC	2904957	1

### 4 Technical data

Hardware/firmware version	
HW/FW	≥ 00/-- (The technical data and safety characteristics are valid as of the specified HW/FW version.)
Input data	
Rated control supply voltage $U_S$	24 V DC -15 % / +10 %
Rated control supply current $I_S$	typ. 42 mA
Typical inrush current	4.5 A ( $\Delta t = 120 \mu s$ at $U_S$ ) < 20 mA (with $U_S/I_x$ to S12) < 10 mA (with $U_S/I_x$ at the start circuit) < 20 mA (with $U_S/I_x$ to S13)
Current consumption	< 5 mA (with $U_S/I_x$ to S12) < 5 mA (with $U_S/I_x$ to S13) < 10 mA (with $U_S/I_x$ at the start circuit)
Power consumption at $U_S$	typ. 1 W
Voltage at input/start and feedback circuit	24 V DC -15 % / +10 %
Filter time	1 ms (at A1 in the event of voltage dips at $U_S$ ) max. 1.5 ms (at S12, S13; test pulse width) min. 7.5 ms (at S12, S13; test pulse rate) Test pulse rate = 5 x Test pulse width
Max. permissible overall conductor resistance (Input and reset circuit at $U_S$ )	150 $\Omega$
Typical response time at $U_S$	< 175 ms
Typical starting time with $U_S$	< 250 ms (when controlled via A1)
Typical release time with $U_S$	< 20 ms (when controlled via A1 or S12 and S13.)
Recovery time	< 500 ms
Maximum switching frequency	0.5 Hz
Operating voltage display	1 x green LED
Status display	2 x green LEDs
Protective circuit	Surge protection Suppressor diode Reverse polarity protection for rated control supply voltage
Output data	
Contact type	1 enabling current path
Contact material	AgSnO <sub>2</sub>
Minimum switching voltage	20 V AC/DC
Maximum switching voltage	250 V AC/DC
Limiting continuous current	6 A (N/O contact)
Maximum inrush current	6 A
Inrush current, minimum	3 mA
Sq. Total current	36 A <sup>2</sup> (see to derating)

**Output data**

Switching capacity min.	60 mW
Mechanical service life	10 x 10 <sup>6</sup> cycles
Output fuse	6 A gL/gG (N/O contact) 4 A gL/gG (for low-demand applications)

**Alarm outputs**

Number of outputs	1 (digital, PNP)
Voltage	22 V DC (U <sub>S</sub> - 2 V)
Current	max. 100 mA
Maximum inrush current	500 mA (Δt = 1 ms at U <sub>S</sub> )
Short-circuit protection	no

**General data**

Relay type	Electromechanically forcibly guided, dust-proof relay.
Nominal operating mode	100% operating factor
Degree of protection	IP20
Min. degree of protection of inst. location	IP54
Mounting type	DIN rail mounting
Mounting position	vertical or horizontal
Assembly instructions	See derating curve
Dimensions (W/H/D)	6.8 x 93.1 x 102.5 mm
Type of housing	PBT yellow
Clearances and creepage distances between the power circuits	DIN EN 50178
Rated insulation voltage	250 V AC
Rated surge voltage/insulation	Safe isolation, reinforced insulation 6 kV between input circuit and enabling current path Basic insulation 4 kV between all current paths and housing
Pollution degree	2
Surge voltage category	III

**Connection data**

Connection method	Screw connection
Conductor cross section, solid	0.2 mm <sup>2</sup> ... 2.5 mm <sup>2</sup>
Conductor cross section, stranded	0.2 mm <sup>2</sup> ... 2.5 mm <sup>2</sup>
Conductor cross section AWG/kcmil	26 ... 12
Stripping length	12 mm
Screw thread	M3

**Ambient conditions**

Ambient temperature (operation)	-40 °C ... 60 °C (observe derating)
Ambient temperature (storage/transport)	-40 °C ... 85 °C
Max. permissible relative humidity (operation)	75 % (on average, 85% infrequently, non-condensing)
Max. permissible humidity (storage/transport)	75 % (on average, 85% infrequently, non-condensing)
Maximum altitude	max. 2000 m (Above sea level)
Shock	15g
Vibration (operation)	10 Hz ...150 Hz, 2g

**Conformance / approvals**

Conformance	CE-compliant
Approvals	

**Safety data**

Stop category according to IEC 60204	0
--------------------------------------	---

**Safety parameters for IEC 61508 - High demand**

SIL	3
PFH <sub>d</sub>	$1.5 \times 10^{-9}$ (4 A DC13; 5 A AC15; 8760 switching cycles/year)
Demand rate	< 12 Months
Proof test interval	240 Months

**Safety parameters for IEC 61508 - Low demand**

SIL	3
PFD <sub>avg</sub>	$1.47 \times 10^{-4}$
Proof test interval	60 Months
Duration of use	240 Months

**Safety parameters for EN 62061**

SIL CL	3
--------	---

**Safety characteristic data according to EN ISO 13849**

Category	4
Performance level	e (4 A DC13; 5 A AC15; 8760 switching cycles/year)
Duration of use	240 Months

For applications in PL e, the required demand rate for the safety function is once per month.

## 5 Safety notes



### **WARNING: Risk of electric shock**

During operation, parts of electrical switching devices carry hazardous voltages.

Before working on the switching device, disconnect the power.

Please observe the safety regulations of electrical engineering and industrial safety and liability associations!

Disregarding these safety regulations may result in death, serious personal injury or damage to equipment.

Startup, mounting, modifications, and upgrades should only be carried out by a skilled electrical engineer!



### **WARNING: Risk of automatic machine restart!**

For emergency stop applications, the machine must be prevented from restarting automatically by a higher-level control system.

Protective covers must not be removed when operating electrical switching devices.



### **WARNING: Danger due to faulty devices!**

The devices may be damaged following an error and correct operation can no longer be ensured.

In the event of an error, replace the device immediately.

Repairs to the device, especially if the housing must be opened, may only be carried out by the manufacturer or authorized persons. Otherwise the warranty is invalidated.



### **WARNING: Risk due to incorrect installation**

For reliable operation, the safety relay must be installed in housing protected from dust and humidity (IP54).

Carry out wiring according to the application. Refer to the "Application examples" section for this.



### **WARNING: Risk due to welded relay contacts**

A suitable and effective protective circuit is to be provided for inductive loads. This is to be implemented parallel to the load and not parallel to the switch contact.



### **WARNING: danger due to magnetic interference!**

Do not use the device in the vicinity of strong magnetic fields (e.g., caused by transformers or magnetic iron). The magnetic field strength of the environment must not exceed 30 A/m.



### **NOTE: Risk of damage to equipment due to noise emissions**

When operating relay modules the operator must meet the requirements for noise emission for electrical and electronic equipment (EN 61000-6-4) on the contact side and, if required, take appropriate measures.



### **NOTE: Risk of damage to equipment due to noise emissions**

This is a Class A product. In a domestic environment it may cause radio interference, in which case the user may be required to take adequate measures.



Only use power supply units with safe isolation and SELV / PELV in accordance with EN 50178/VDE 0160 (SELV / PELV).



### **NOTE: Electrostatic discharge!**

The device contains components that can be damaged or destroyed by electrostatic discharge. When handling the device, observe the necessary safety precautions against electrostatic discharge (ESD) according to EN 61340-5-1 and EN 61340-5-2.

## 6 Basic circuit diagram

Key:

Designation	Explanation
A1	+24 V power supply
A2	0 V power supply
S12	Input sensor circuit (channel 1)
S13	Input sensor circuit (channel 2)
S35 (PSR-MS50 only)	Automatic start
S34 (PSR-MS55 only)	Manual, monitored start
13/14	Enabling current path, undelayed
M1	Signal output (PNP)

### 6.1 Block diagram PSR-MS50

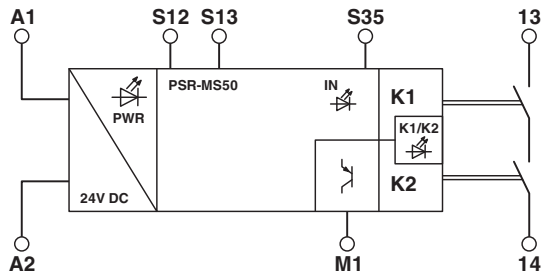

Figure 1 Block diagram PSR-MS50

### 6.2 Block diagram PSR-MS55

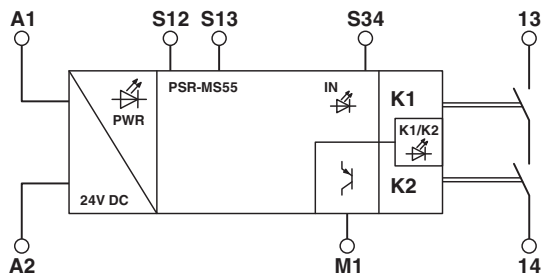

Figure 2 Block diagram PSR-MS55

## 7 Derating

### 7.1 Vertical or horizontal mounting position

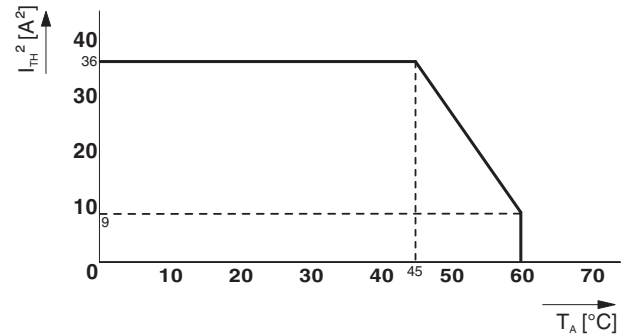

Figure 3 Derating curve - vertical or horizontal mounting position with connected modules

## 8 Load curve

### 8.1 Ohmic load

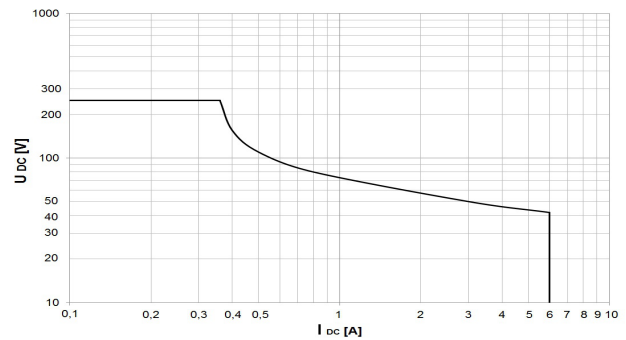

Figure 4 Relay load curve - ohmic load

## 9 Function/time diagrams

Key:

Designation	Explanation
A1/A2	Power supply
S35 (PSR-MS50 only)	Automatic start
S34 (PSR-MS55 only)	Manual, monitored start
S12	Input sensor circuit (channel 1)
S13	Input sensor circuit (channel 2)
13/14	Enabling current path, undelayed
M1	Signal output (PNP)

### 9.1 Time diagram PSR-MS50

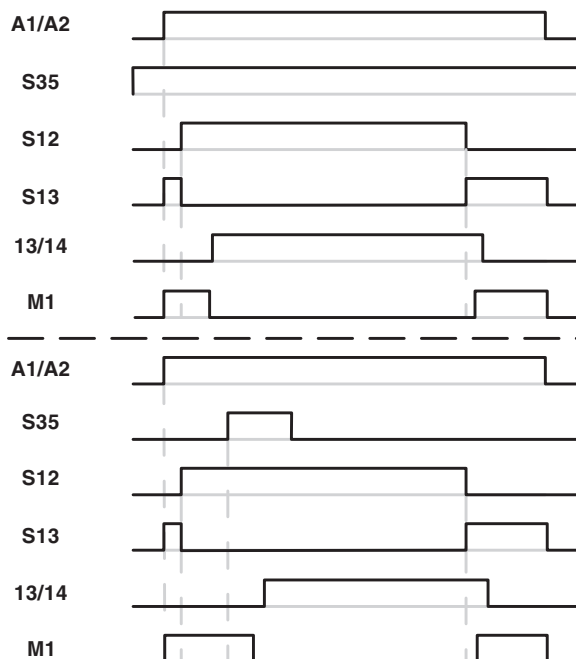

Figure 5 Time diagram PSR-MS50

### 9.2 Time diagram PSR-MS55

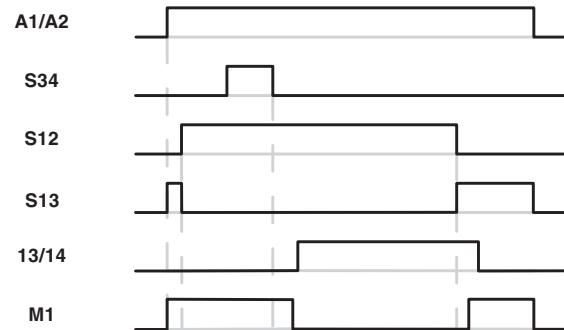

Figure 6 Time diagram PSR-MS55

## 10 Operating and indication elements

### 10.1 Connection versions

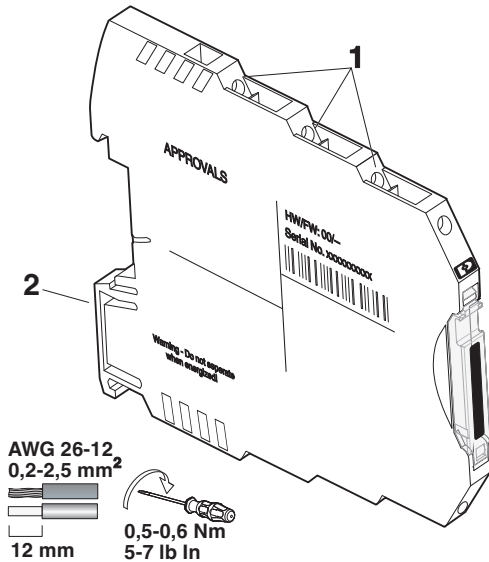

Figure 7 Connection versions

- 1 Fixed screw connection
- 2 Snap-on foot for DIN rail mounting



The year the device was constructed can be found underneath the CE designation on the housing.

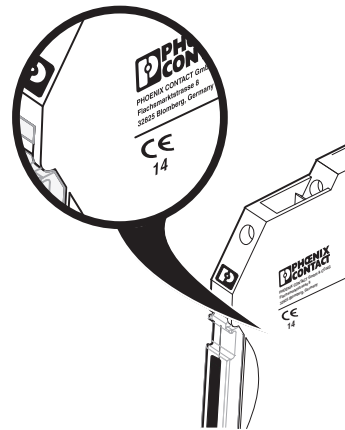
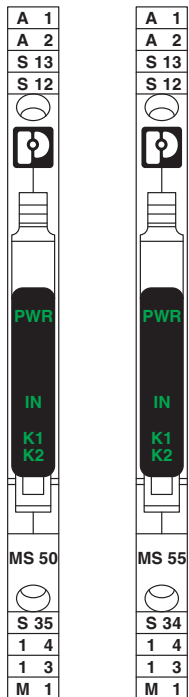

Figure 8 Year of manufacture of the device

### 10.2 Connection assignment

#### Figure



#### Designation

A1

A2

S13

S12

PWR

IN

K1/K2

S35 (PSR-MS50 only)

S34 (PSR-MS55 only)

13/14

M1

#### Explanation

+24 V power supply

0 V power supply

Input sensor circuit (channel 2)

Input sensor circuit (channel 1)

Power LED (green)

Status indicator sensor circuit; LED (green)

Status indicator safety circuit; LED (green)

Automatic start

Manual, monitored start

Enabling current path, undelayed

Signal output (PNP)

## 11 Mounting and connection

Mount the module on a 35 mm DIN rail according to EN 60715.

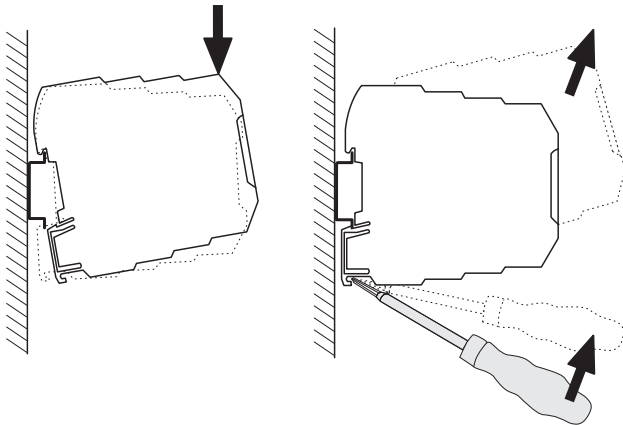

Figure 9 Mounting and removing

Connect the cables to the connection terminal blocks using a screwdriver.

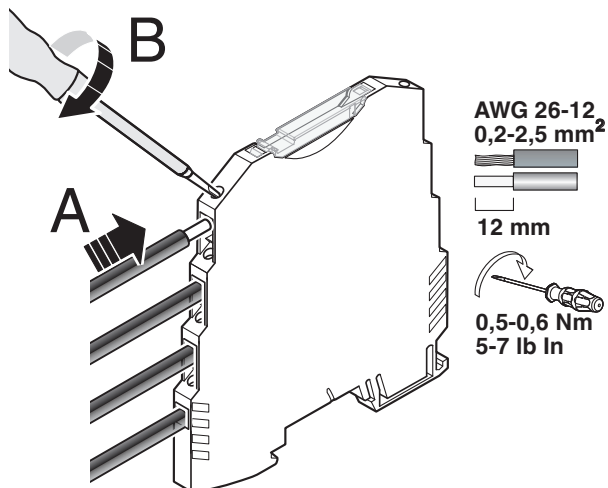

Figure 10 Connection of the cables



For compliance with UL approval, use copper wire that is approved up to 60°C/75°C.

## 12 Startup

Apply the rated control supply voltage (24 V DC) at terminal blocks A1/A2. The PWR LED lights up.

Close sensor circuit channel 1 (24 V/S12) and open channel 2 (24 V/S13). The IN LED lights up.

### Automatic start (PSR-MS50 only):

Close contacts 24 V/S35. The enabling current path closes.

### Manual, monitored start (PSR-MS55 only):

Close contacts 24 V/S34. When the start circuit is then opened, the enabling current path is closed.

The K1/K2 LED lights up.

If the rated control supply voltage drops or the safety equipment is opened, the enabling current path of the output circuit (13/14) opens and the contacts enter the safe state.

## 13 Calculating the power dissipation



The total power dissipation of the safety relay is based on the input power dissipation and the contact power dissipation for the same and for different load currents.

### Input power dissipation

$$P_{\text{Input}} = U_B^2 / (U_S / I_S)$$

### Contact power dissipation

With the same load currents:

$$P_{\text{Contact}} = n \cdot I_L^2 \cdot 50 \text{ m}\Omega$$

With different load currents:

$$P_{\text{Contact}} = (I_{L1}^2 + I_{L2}^2 + \dots + I_{Ln}^2) \cdot 50 \text{ m}\Omega$$

### Total power dissipation

$$P_{\text{Total}} = P_{\text{Input}} + P_{\text{Contact}}$$

therefore

$$P_{\text{Total}} = U_B^2 / (U_S / I_S) + n \cdot I_L^2 \cdot 50 \text{ m}\Omega$$

or

$$P_{\text{Total}} = U_B^2 / (U_S / I_S) + (I_{L1}^2 + I_{L2}^2 + \dots + I_{Ln}^2) \cdot 50 \text{ m}\Omega$$

### Key:

Designation	Explanation
P	Power dissipation in mW
$U_B$	Applied operating voltage
$U_S$	Rated control supply voltage
$I_S$	Rated control supply current
n	Number of enabling current paths used
$I_L$	Contact load current

## 14 Diagnostics

The following section describes the LED indicators for general states and error messages as well as possible causes and remedies.

### Function test/proof test



Use the function test to check the safety function. To do this, request the safety function once by pressing the emergency stop button, for example. Check whether the safety function is running correctly by switching the device on again via the sensor circuits.

#### 14.1 General states

PWR LED	IN LED	K1/K2 LED	State	Notes
ON	OFF	OFF	All relays are not activated. The sensor circuit is off.	Possible error see error messages
ON	ON	OFF	The sensor circuit is active. Relays K1 and K2 are ready to start and await reset/start command (S34 or S35).	-
ON	ON	ON	The sensor circuit is active. All relays are picked up.	-

#### 14.2 Error Messages

PWR LED	IN LED	K1/K2 LED	State	Possible cause	Remedy
ON	OFF	OFF	The sensor circuit is actively controlled, but no input LEDs are lit up.	Internal cross-circuit detection (via non-equivalence) is active: potential cross-circuit in the sensor circuit.	Check the sensor circuit/signal generator. Then perform a function test.
ON	ON	OFF	The sensor circuit is active. The reset/start circuit (S34 or S35) is/was activated. The safety circuit (K1 and K2) is not picking up.	External error: the readback contact (external actuator) is open in the reset circuit. Internal error: 1. The diagnostic contact is not working correctly. 2. An N/O contact is welded.	External error: check the actuator. Internal error: perform a power down reset with subsequent function test. <b>If the error occurs again after the function test, replace the device.</b>
ON	ON	OFF	The sensor circuit is active. The reset/start circuit (S34 or S35) is/was activated. The safety circuit (K1 and K2) is not picking up.	Error in the sensor circuit.	Check the sensor circuit. Then perform a function test. <b>If the error occurs again after the function test, replace the device.</b>
ON	ON	OFF	The sensor circuit is active. The reset/start circuit (S34) is/was activated. The safety circuit (K1 and K2) is not picking up.	Error during manual reset S34 (stuck-at at the input).	Remove the error in the reset/start circuit. Then perform a function test.
OFF	OFF	OFF	The sensor circuit is active.	1. No supply voltage at A1/A 2. Over- or undervoltage at A1	Check the supply voltage.

## 15 Application examples

### Key:

- S2 = Manual reset device
- S3 = Solenoid switch
- K1/K2 = Contactors



Cross-circuits in the cable installation can be excluded if the safety relay and external contactors K1 and K2 are located in the same electrical installation space.

### Applications with the PSR-MS50

#### 15.1 Magnetic switch monitoring/automatic start

- Two-channel, non-equivalent magnetic switch monitoring
- Automatic start
- Suitable up to category 4, PL e (EN ISO 13849-1), SILCL 3 (EN 62061), if cross-circuits in the control to the actuator can be ruled out

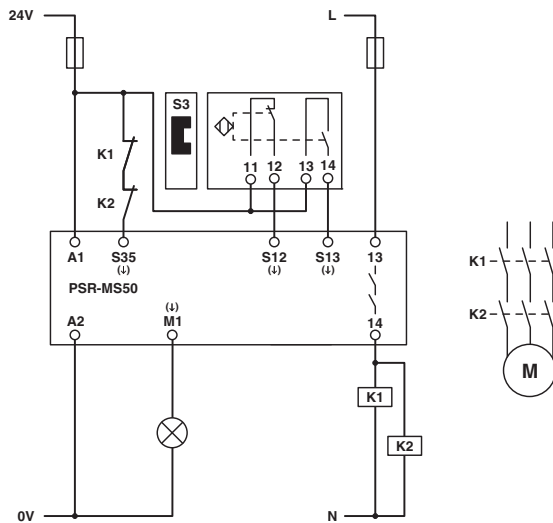

Figure 11 Magnetic switch monitoring/automatic start

### Applications with the PSR-MS55

#### 15.2 Magnetic switch monitoring/manual, monitored start

- Two-channel, non-equivalent magnetic switch monitoring
- Manual, monitored start
- Suitable up to category 4, PL e (EN ISO 13849-1), SILCL 3 (EN 62061), if cross-circuits in the control to the actuator can be ruled out

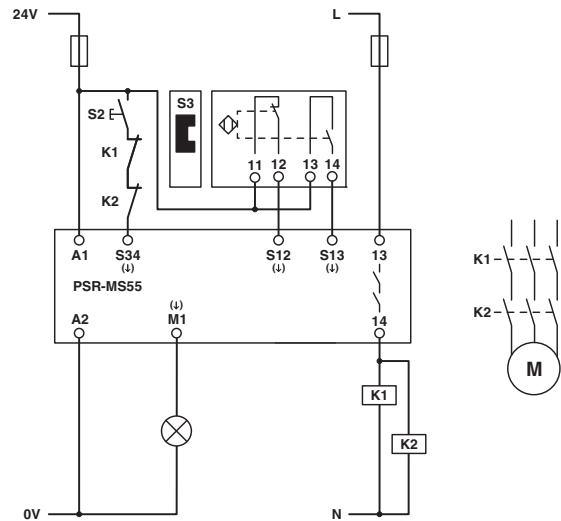

Figure 12 Magnetic switch monitoring/manual, monitored start

## 16 Revision history

Version	Date	Contents
00	2014-12-03	First publication
01	2015-03-05	Reverse polarity protection extended; relay type extended; dimensions updated; load curve extended
01_c00	2015-05-19	Caption of figure 4 corrected (translation error)