

## 2/2-way proportional valve



Type 2835 can be combined with...



**Type 8605**

Digital control electronics  
Cable plug version

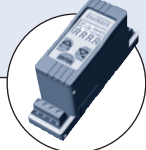

**Type 8605**

Digital control electronics  
DIN-rail version

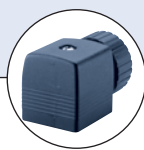

**Type 2508**

Cable plug

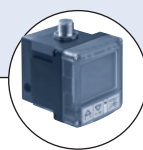

**Type 8611**

Universal controller

The direct-acting proportional valve Type 2835 can be used as a control valve for process control and is suitable for technical vacuum. Low hysteresis, high repeatability and high sensitivity ensure superior regulation behavior. Thanks to an elastomeric sealing, the valve closes tightly and securely.

### Circuit function A

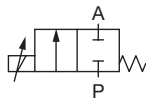

Direct acting 2-way  
proportional valve,  
normally closed

Valve control takes place through the control electronics of Type 8605, which converts an analogue input signal into a PWM signal<sup>1)</sup>.

Further, functional features of the Type 8605 electronic control unit:

- Temperature compensation for coil heating by internal current regulation
- Simple zero and span settings
- Ramp function to dampen fast status changes

Technical Data - valve	
<b>Body material</b>	Brass, Stainless steel
<b>Seal material</b>	FKM, EPDM on request
<b>Media</b>	Neutral gases, liquids
<b>Medium temperature</b>	-10 ... +90 °C
<b>Ambient temperature</b>	max. +55 °C
<b>Viscosity</b>	max. 21 mm <sup>2</sup> /s
<b>Operating voltage</b>	24 V DC
<b>Power consumption</b>	16 W
<b>Duty cycle</b>	100 % continuously rated
<b>Port connection</b>	G 3/8, G 1/2, NPT 3/8, NPT 1/2
<b>Electric connection</b>	Cable plug (DIN EN 175301-803 Form A)
<b>Installation</b>	As required, preferably with actuator in upright position
<b>Typical control data<sup>2)</sup></b>	
Hysteresis	< 5 %
Repeatability	< 0,25 % v. F.S.
Sensitivity	< 0,25 % v. F.S.
Turn-down ratio	1:100
<b>Protection class - valve</b>	IP65

<sup>1)</sup> PWM pulse-width modulation

<sup>2)</sup> Characteristic data of control behaviour depends on process conditions

Dimensions [mm]

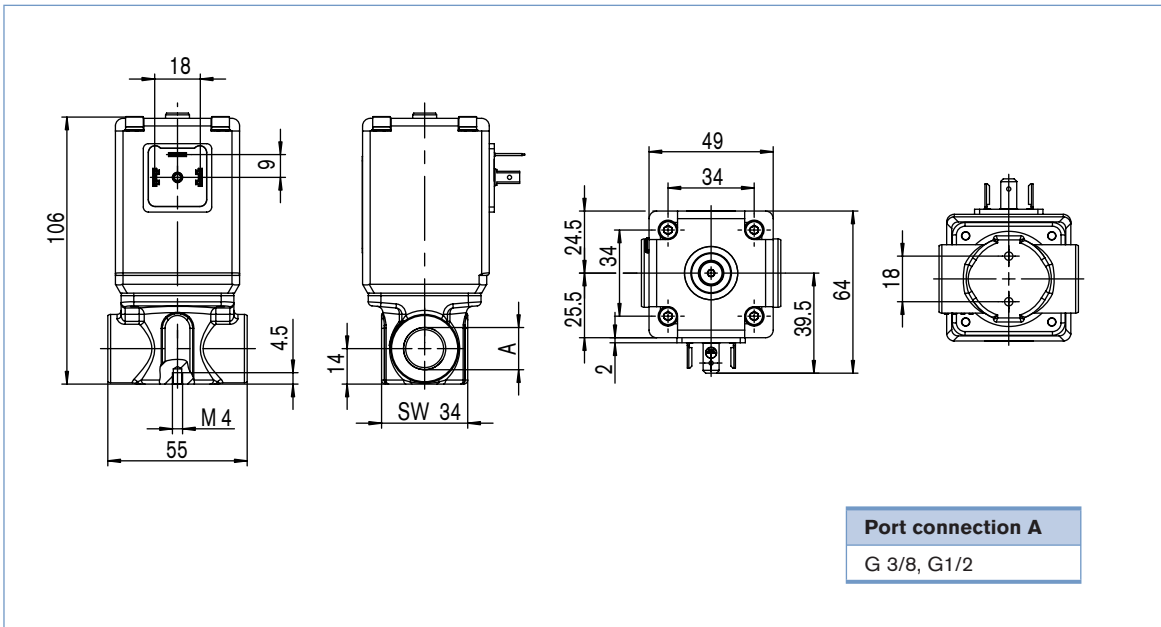

**Port connection A**  
G 3/8, G1/2

Characteristics of a proportional valve

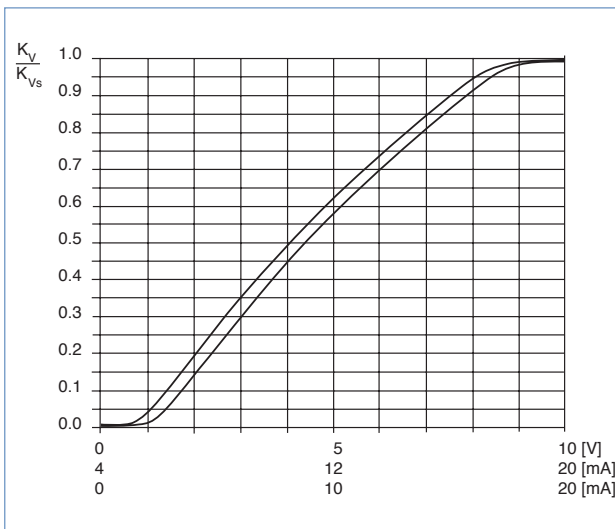

Advice for valve sizing

In continuous flow applications, the choice of appropriate valve size is much more important than with on/off valves. The optimum size should be selected such that the resulting flow in the system is not unnecessarily reduced by the valve. However, a sufficient part of the pressure drop should be taken across the valve even when it is fully opened.

**recommended value:  $\Delta p_{\text{valve}} > 30\%$  of total pressure drop within the system**

For that reason take advantage of Bürkert competent engineering services during the planning phase!

Determination of the kv value

Pressure drop	kv value for liquids [m³/h]	kv value for gases [m³/h]
Subcritical $p_2 > \frac{p_1}{2}$	$= Q \sqrt{\frac{\rho}{1000 \Delta p}}$	$= \frac{Q_N}{514} \sqrt{\frac{T_1 \rho_N}{p_2 \Delta p}}$
Supercritical $p_2 < \frac{p_1}{2}$	$= Q \sqrt{\frac{\rho}{1000 \Delta p}}$	$= \frac{Q_N}{257 p_1} \sqrt{T_1 \rho_N}$

- $k_v$  Flow coefficient [m³/h]<sup>1)</sup>
- $Q_N$  Standard flow rate [m<sup>3</sup>/h]<sup>2)</sup>
- $p_1$  Inlet pressure [bar]<sup>3)</sup>
- $p_2$  Outlet pressure [bar]<sup>3)</sup>
- $\Delta p$  Differential pressure  $p_1 - p_2$  [bar]
- $\rho$  Density [kg/m³]
- $\rho_N$  Standard density [kg/m³]
- $T_1$  Temperature if fluid medium [(273+t)K]

<sup>1)</sup> measured for water,  $\Delta p = 1$  bar, via the device

<sup>2)</sup> Standard conditions at 1.013 bar<sup>3)</sup> and 0 °C (273K)

<sup>3)</sup> Absolute pressure

## Ordering chart for valves

### All valves with FKM sealing

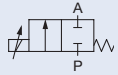
Circuit function	Orifice [mm]	Port connection	k <sub>v</sub> value water [m <sup>3</sup> /h] <sup>1)</sup>	Q <sub>Nn</sub> value [l/min] <sup>2)</sup>	Maximum pressure [bar] <sup>3)</sup>	Coil power consumption [W]	Maximum coil current [mA]	Item no. Brass body	Item no. Stainless steel body
A 2/2-way normally closed (NC) 	2 <sup>4)</sup>	G 3/8	0.12	129	25	16	750	175 980	175 996
		NPT 3/8	0.12	129	25	16	750	175 997	175 998
	3	G 3/8	0.25	270	10	16	750	175 999	176 000
		NPT 3/8	0.25	270	10	16	750	176 001	176 002
	4	G 3/8	0.45	485	8	16	750	176 003	176 004
		NPT 3/8	0.45	485	8	16	750	175 995	175 984
		G 1/2	0.45	485	8	16	750	176 005	176 006
	6	NPT 1/2	0.45	485	8	16	750	175 985	175 986
		G 1/2	0.80	862	4	16	750	175 989	175 990
	8	NPT 1/2	0.80	862	4	16	750	175 993	175 994
		G 1/2	1.10	1186	2	16	750	178 794	179 412
			NPT 1/2	1.10	1186	2	16	750	179 305

<sup>1)</sup> kVs value: Flow rate value for water, measured at +20 °C and 1 bar pressure differential over a fully opened valve.

<sup>2)</sup> QNn value: Flow rate value for air with inlet pressure of 6 bar<sup>1)</sup>, 1 bar pressure differential and +20 °C.

<sup>3)</sup> Pressure data [bar]: Overpressure with respect to atmospheric pressure

<sup>4)</sup> for Δp>10bar it is possible to get discontinuities in the characteristic curve because of flow conditions in the application

**Please note** that the valves are delivered without control electronics unit and cable plug (see accessories below).

### Further versions on request



#### Materials

Seal: FFKM (resistant to aggressive media), EPDM



#### Analytical

Oxygen version  
Part oil-, fat- and silicon free



#### Electrical connection

12 V coil



#### Approvals

UL recognised, CSA, Ex version - II 2G EEx m IIC T4, PTB No. 02 ATEX 2094X with or without terminal box

## Ordering chart for accessories

### Cable plug Type 2508 according to DIN EN 175301-803 Form A

The delivery of a cable plug includes the flat seal and fixing screw

Circuitry	Voltage / frequency	Item no.
None	0 - 250 V AC/DC	008 376
None, with 3 m cable	0 - 250 V AC/DC	783 573

### Electronic Control Type 8605

Please see Datasheet