

- NOTES:
- MATERIAL:
HOUSING: GLASS FILLED LCP (LIQUID CRYSTAL POLYMER), UL94V-0; COLOR: BLACK
POWER CONTACT: COPPER ALLOY
SIGNAL CONTACT: PHOSPHOR BRONZE
 - FINISH: SELECT GOLD 0.76 MICROMETER/30 MICORINCH MINIMUM;
SELECT TIN 3.81 MICROMETER/150 MICORINCH MINIMUM;
BOTH OVER NICKEL 1.27 MICROMETER/50 MICORINCH MINIMUM.
 - PRODUCT SPECIFICATION: PS-45984-001
 - PACKAGING SPECIFICATION: TRAY PER PK-45984-001.
 - SEE SHEET 5 FOR CIRCUIT IDENTIFICATION.
 - PARTS ARE RoHS COMPLIANT.
 - PEG HOLES ARE OPTIONAL PCB FEATURES AND ARE REQUIRED ONLY WITH THE PEGGED OPTIONS.
 - MATES WITH MOLEX RECEPTACLE SERIES 45984-4***.

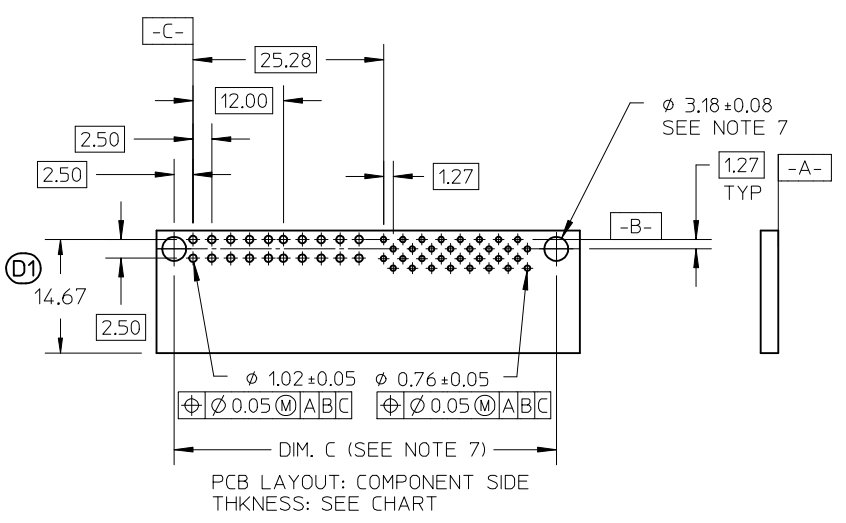

NO OF SIGNAL	MATERIAL NUMBER	DIM A REF	DIM P	PCB THK
12	45985-4111	36.16	4.50	3.18
16	45985-4121	38.70		
20	45985-4131	41.24		
24	45985-4141	43.78		
28	45985-4151	46.32		
32	45985-4161	48.86		
36	45985-4171	51.40		
40	45985-4181	53.94		
12	45985-4112	36.16	3.90	2.36
16	45985-4122	38.70		
20	45985-4132	41.24		
24	45985-4142	43.78		
28	45985-4152	46.32		
32	45985-4162	48.86		
36	45985-4172	51.40		
40	45985-4182	53.94		
12	45985-4113	36.16	2.90	1.57
16	45985-4123	38.70		
20	45985-4133	41.24		
24	45985-4143	43.78		
28	45985-4153	46.32		
32	45985-4163	48.86		
36	45985-4173	51.40		
40	45985-4183	53.94		

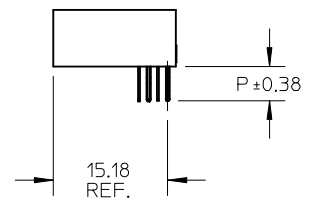
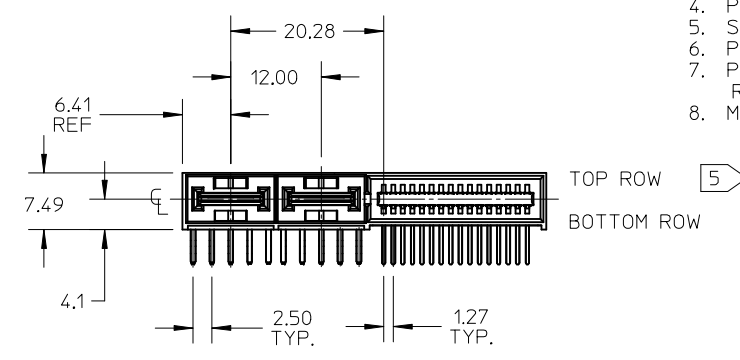
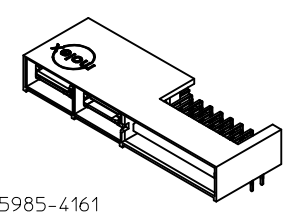

45985-4161
(SHOWN FOR REFERENCE)
SEE CHART

ADD DIMENSION	DESCRIPTION
EC NO: UCP2015-3913	
DRWN: JUILLES 2015/03/24	
CHKD: MBANDURA 2015/03/24	
APPR: APATEL 2015/04/09	
D1	REV

GENERAL TOLERANCES (UNLESS SPECIFIED)		
	mm	INCH
4 PLACES	± ---	± ---
3 PLACES	± ---	± ---
2 PLACES	± 0.25	± ---
1 PLACE	± ---	± ---
ANGULAR ±1/2°		
DRAFT WHERE APPLICABLE MUST REMAIN WITHIN DIMENSIONS		

DIMENSION STYLE	
MM ONLY	
DRAWN BY	DATE
JSCHAFFER	6-10-05
CHECKED BY	DATE
YMARGULIS	6-14-05
APPROVED BY	DATE
YMARGULIS	6-15-05
MATERIAL NO.	
SEE CHART	
SIZE	
A	

SCALE	DESIGN UNITS	THIRD ANGLE PROJECTION	
1:1	METRIC		
TITLE			
LPH PLUG ASSEMBLY RT ANGLE 4 CIRCUIT POWER CONNECTOR			
molex MOLEX INCORPORATED			
DOCUMENT NO.			SHEET NO.
SD-45985-400			1 OF 5
THIS DRAWING CONTAINS INFORMATION THAT IS PROPRIETARY TO MOLEX INCORPORATED AND SHOULD NOT BE USED WITHOUT WRITTEN PERMISSION			

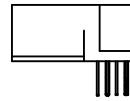
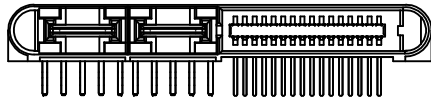
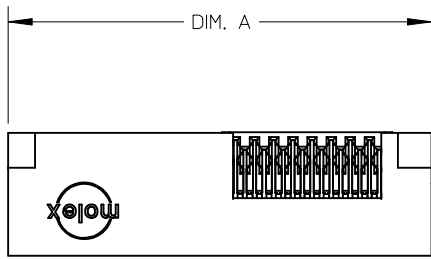

GUIDE OPTIONS

NO OF SIGNAL	MATERIAL NUMBER	DIM A REF	DIM P	PCB THK
12	45985-4211	43.66	4.50	3.18
16	45985-4221	46.20		
20	45985-4231	48.74		
24	45985-4241	51.28		
28	45985-4251	53.82		
32	45985-4261	56.36		
36	45985-4271	58.90	3.90	2.36
40	45985-4281	61.44		
12	45985-4212	43.66		
16	45985-4222	46.20		
20	45985-4232	48.74		
24	45985-4242	51.28		
28	45985-4252	53.82	2.90	1.57
32	45985-4262	56.36		
36	45985-4272	58.90		
40	45985-4282	61.44		
12	45985-4213	43.66		
16	45985-4223	46.20		
20	45985-4233	48.74	2.90	1.57
24	45985-4243	51.28		
28	45985-4253	53.82		
32	45985-4263	56.36		
36	45985-4273	58.90		
40	45985-4283	61.44		

NOTE:
1. SEE SHEET 1 FOR DIMENSIONS NOT SHOWN.

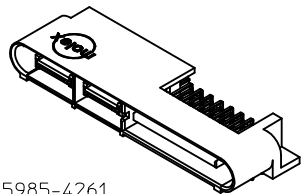

45985-4261
(SHOWN FOR REFERENCE)
SEE CHART

SEE SHEET 1 EC NO: UCP2015-3913 DRWN: JUILLES 2015/03/24 CHKD: MBANDURA 2015/03/24 APPR: APATEL 2015/04/09	DESCRIPTION	GENERAL TOLERANCES (UNLESS SPECIFIED)		DIMENSION STYLE MM ONLY		SCALE 1:1	DESIGN UNITS METRIC	THIRD ANGLE PROJECTION	
			mm	INCH	DRAWN BY JSCHAFFER	DATE 6-10-05	TITLE LPH PLUG ASSEMBLY RT ANGLE 4 CIRCUIT POWER CONNECTOR		
	4 PLACES	± ---	± ---	CHECKED BY YMARGULIS	DATE 6-14-05	MOLEX INCORPORATED			
	3 PLACES	± ---	± ---	APPROVED BY YMARGULIS	DATE 6-15-05				
	2 PLACES	± 0.25	± ---	MATERIAL NO. SEE CHART		SHEET NO. 2 OF 5			
	1 PLACE	± ---	± ---	SIZE A					
		ANGULAR ±1/2°		DRAFT WHERE APPLICABLE MUST REMAIN WITHIN DIMENSIONS					

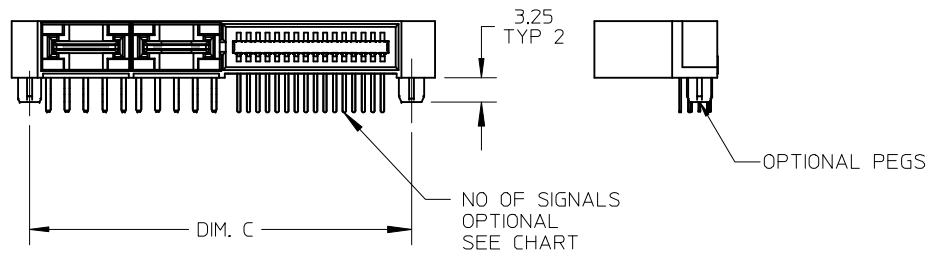
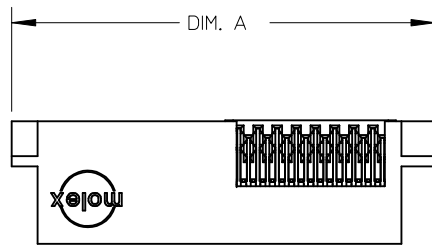

MOUNTING PEG OPTIONS

NO OF SIGNAL	MATERIAL NUMBER	DIM A REF	DIM C	DIM P	PCB THK
12	45985-4311	43.66	37.98	4.50	3.18
16	45985-4321	46.20	40.52		
20	45985-4331	48.74	43.06		
24	45985-4341	51.28	45.60		
28	45985-4351	53.82	48.14		
32	45985-4361	56.36	50.68		
36	45985-4371	58.90	53.22	3.90	2.36
40	45985-4381	61.44	55.76		
12	45985-4312	43.66	37.98		
16	45985-4322	46.20	40.52		
20	45985-4332	48.74	43.06		
24	45985-4342	51.28	45.60		
28	45985-4352	53.82	48.14		
32	45985-4362	56.36	50.68		
36	45985-4372	58.90	53.22		
40	45985-4382	61.44	55.76	2.90	1.57
12	45985-4313	43.66	37.98		
16	45985-4323	46.20	40.52		
20	45985-4333	48.74	43.06		
24	45985-4343	51.28	45.60		
28	45985-4353	53.82	48.14		
32	45985-4363	56.36	50.68		
36	45985-4373	58.90	53.22		
40	45985-4383	61.44	55.76		

NOTE:
1. SEE SHEET 1 FOR DIMENSIONS NOT SHOWN.

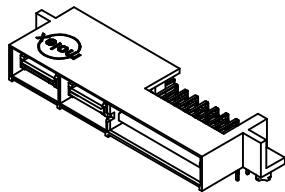

45985-4361
(SHOWN FOR REFERENCE)
SEE CHART

SEE SHEET 1 EC NO: UCP2015-3913 DRWN: JUILLES 2015/03/24 CHKD: MBANDURA 2015/03/24 APPR: APATEL 2015/04/09	DESCRIPTION	GENERAL TOLERANCES (UNLESS SPECIFIED)		DIMENSION STYLE MM ONLY		SCALE 1:1	DESIGN UNITS METRIC	THIRD ANGLE PROJECTION		
			mm	INCH	DRAWN BY JSCHAFFER	DATE 6-10-05	TITLE LPH PLUG ASSEMBLY RT ANGLE 4 CIRCUIT POWER CONNECTOR			
		4 PLACES	± ---	± ---	CHECKED BY YMARGULIS	DATE 6-14-05				
		3 PLACES	± ---	± ---	APPROVED BY YMARGULIS	DATE 6-15-05	MOLEX INCORPORATED			
2 PLACES	± 0.25	± ---	MATERIAL NO. SEE CHART		DOCUMENT NO. SD-45985-400	SHEET NO. 3 OF 5				
D1	REV	ANGULAR ±1/2°		DRAFT WHERE APPLICABLE MUST REMAIN WITHIN DIMENSIONS		THIS DRAWING CONTAINS INFORMATION THAT IS PROPRIETARY TO MOLEX INCORPORATED AND SHOULD NOT BE USED WITHOUT WRITTEN PERMISSION				

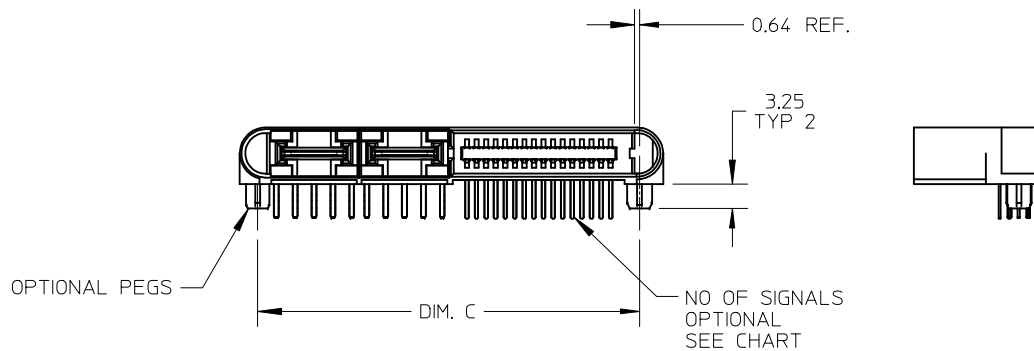
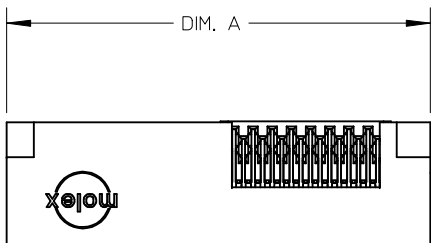

NO OF SIGNAL	MATERIAL NUMBER	DIM A REF	DIM C	DIM P	PCB THK
12	45985-4411	43.66	37.98	4.50	3.18
16	45985-4421	46.20	40.52		
20	45985-4431	48.74	43.06		
24	45985-4441	51.28	45.60		
28	45985-4451	53.82	48.14		
32	45985-4461	56.36	50.68		
36	45985-4471	58.90	53.22	3.90	2.36
40	45985-4481	61.44	55.76		
12	45985-4412	43.66	37.98		
16	45985-4422	46.20	40.52		
20	45985-4432	48.74	43.06		
24	45985-4442	51.28	45.60		
28	45985-4452	53.82	48.14		
32	45985-4462	56.36	50.68		
36	45985-4472	58.90	53.22	2.90	1.57
40	45985-4482	61.44	55.76		
12	45985-4413	43.66	37.98		
16	45985-4423	46.20	40.52		
20	45985-4433	48.74	43.06		
24	45985-4443	51.28	45.60		
28	45985-4453	53.82	48.14		
32	45985-4463	56.36	50.68		
36	45985-4473	58.90	53.22		
40	45985-4483	61.44	55.76		

GUIDE & MOUNTING PEG OPTIONS

NOTE:
1. SEE SHEET 1 FOR DIMENSIONS NOT SHOWN.

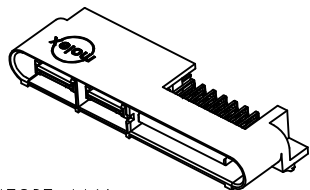

45985-4461
(SHOWN FOR REFERENCE)
SEE CHART

SEE SHEET 1 EC NO: UCP2015-3913 DRWN: JUILLES 2015/03/24 CHKD: MBANDURA 2015/03/24 APPR: APATEL 2015/04/09	DESCRIPTION	GENERAL TOLERANCES (UNLESS SPECIFIED)		DIMENSION STYLE MM ONLY		SCALE 1:1	DESIGN UNITS METRIC	THIRD ANGLE PROJECTION		
			mm	INCH	DRAWN BY JSCHAFFER	DATE 6-10-05	TITLE LPH PLUG ASSEMBLY RT ANGLE 4 CIRCUIT POWER CONNECTOR			
		4 PLACES	± ---	± ---	CHECKED BY YMARGULIS	DATE 6-14-05				
		3 PLACES	± ---	± ---	APPROVED BY YMARGULIS	DATE 6-15-05	MOLEX INCORPORATED			
2 PLACES	± 0.25	± ---	ANGULAR ±1/2°		MATERIAL NO. SEE CHART	DOCUMENT NO. SD-45985-400	SHEET NO. 4 OF 5			
1 PLACE	± ---	± ---	DRAFT WHERE APPLICABLE MUST REMAIN WITHIN DIMENSIONS		SIZE A	THIS DRAWING CONTAINS INFORMATION THAT IS PROPRIETARY TO MOLEX INCORPORATED AND SHOULD NOT BE USED WITHOUT WRITTEN PERMISSION				

CIRCUIT NUMBERING SYSTEM

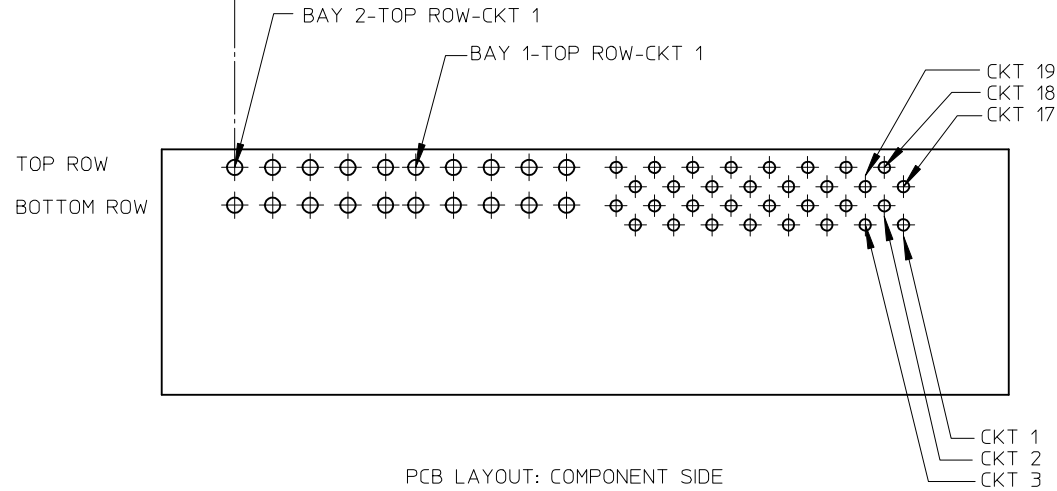
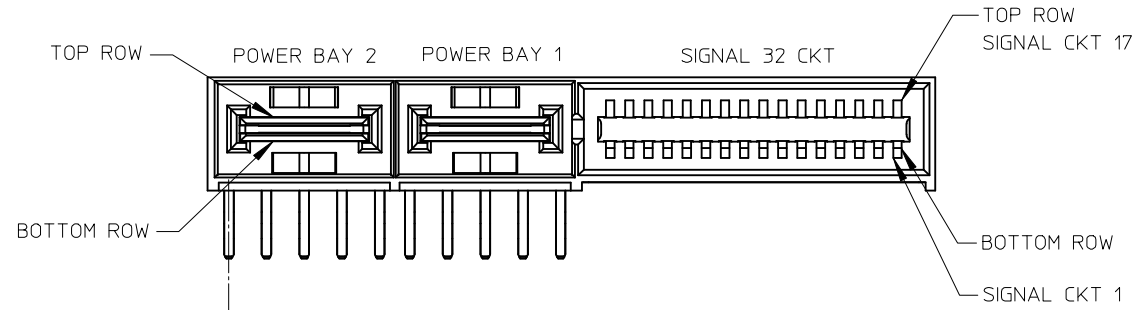

SEE SHEET 1 EC NO: UCP2015-3913 DRWN: JOUILLES 2015/03/24 CHKD: MBANDURA 2015/03/24 APPR: APATEL 2015/04/09	DESCRIPTION	GENERAL TOLERANCES (UNLESS SPECIFIED)		DIMENSION STYLE MM ONLY		SCALE 2:1	DESIGN UNITS METRIC	THIRD ANGLE PROJECTION	
			mm	INCH	DRAWN BY JSCHAFFER	DATE 6-10-05	TITLE LPH PLUG ASSEMBLY RT ANGLE 4 CIRCUIT POWER CONNECTOR		
		4 PLACES	± ---	± ---	CHECKED BY YMARGULIS	DATE 6-14-05			
		3 PLACES	± ---	± ---	APPROVED BY YMARGULIS	DATE 6-15-05	MOLEX INCORPORATED		
		2 PLACES	± 0.25	± ---	MATERIAL NO. SEE CHART				
1 PLACE	± ---	± ---	DRAFT WHERE APPLICABLE MUST REMAIN WITHIN DIMENSIONS						